

TECHNICAL MANUAL

**DIRECT SUPPORT AND GENERAL SUPPORT
MAINTENANCE MANUAL**

FOR

**TRACTOR, WHEELED,
DED, LOADER BACKHOE:
WITH HYDRAULIC IMPACT TOOL AND
WITH HYDRAULIC EARTH AUGER ATTACHMENT
JOHN DEERE MODEL JD410 (CCE)
WITH BUCKET, IMPACTOR,
AND EARTH DRILL
(NSN 2420-00-567-0135)**

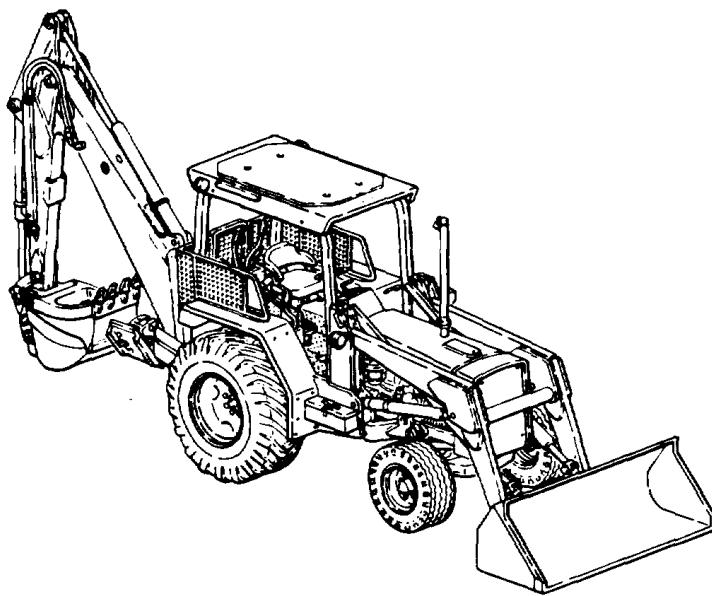

Troubleshooting	2-1
Engine Assembly	3-1
Clutch Assembly	4-1
Fuel System	5-1
Transmission	8-1
Front and Rear Axles	9-1
Brake System	10-1
Steering System	11-1
Body and Accessories	13-1
Hydraulic System	14-1
Cranes, Shovels, and Earthmoving Equipment	15-1
Appendices	A-1

This manual and LO 5-2420-222-12, TM 5-2420-222-20P, and TM 5-2420-222-34P supersede TM 5-2420-222-14&P-1, dated 1 January 1987, and TM 5-2420-222-14&P-2, dated 1 November 1986, including all changes.

Approved for public release; distribution is unlimited.

HEADQUARTERS, DEPARTMENT OF THE ARMY

26 AUGUST 1992

FOR INFORMATION ON FIRST AID, REFER TO FM 21-11.

WARNING

CARBON MONOXIDE EXHAUST GASES CAN KILL!

Carbon monoxide is a colorless, odorless, deadly poisonous gas which, when breathed, deprives the body of oxygen and causes suffocation. Exposure to air containing carbon monoxide produces symptoms of headache, dizziness, loss of muscular control, apparent drowsiness, and coma. Permanent brain damage or death can result from severe exposure.

Carbon monoxide occurs in exhaust fumes of internal combustion engines. Carbon monoxide can become dangerously concentrated under conditions of inadequate ventilation. The following precautions must be observed to ensure safety of personnel when engine of loader backhoe is operated for any purpose.

- (1) DO NOT operate loader backhoe engine in enclosed areas.
- (2) DO NOT idle loader backhoe engine without ventilator blower operating.
- (3) BE ALERT at all times for exhaust odors.
- (4) BE ALERT for exhaust poisoning symptoms. They are:
 - Headache
 - Dizziness
 - Sleepiness
 - Loss of muscular control
- (5) If you see another person with exhaust poisoning symptoms:
 - Remove person from area.
 - Expose to fresh air.
 - Keep person warm.
 - Do not permit physical exercise.
 - Administer artificial respiration, if necessary.
 - Notify a medic.
- (6) BE AWARE: The field protective mask for chemical-biological-radiological (CBR) protection will not protect you from carbon monoxide poisoning.

The Best Defense Against Carbon Monoxide Poisoning Is Good Ventilation.

WARNING**ASBESTOS HAZARD**

DO NOT handle clutch assembly components unless area has been properly cleaned. There may be asbestos dust on these components which can be dangerous if you touch it or breathe it. Wear an approved filter mask and gloves. Never use compressed air or a dry brush to clean clutch assembly components. Dust may be removed using an Industrial-type vacuum cleaner. Clean dust or mud away from brake components with water and a wet, soft brush or cloth. Failure to follow this warning may result in serious illness or death to personnel.

WARNING**CLEANING AGENTS**

- Dry cleaning solvent, P-D-680, is toxic and flammable. Always wear protective goggles and gloves, and use only in a well-ventilated area. Avoid contact with skin, eyes, and clothes, and DO NOT breathe vapors. DO NOT use near open flame or excessive heat. The solvent's flash point is 100°F-138 F (38° C-59° C). If you become dizzy while using cleaning solvent, immediately get fresh air and medical help. If solvent contacts eyes, immediately wash your eyes and get medical aid.
- Cleaning compound, trichlorotrifluoroethane, for electrical parts is toxic and flammable, and reacts violently with aluminum, titanium, barium, lithium, samarium, sodium, and potassium. Always wear protective goggles and rubber gloves, and use only in a well-ventilated area. DO NOT wear jewelry while using cleaning compound. Avoid contact with skin, eyes, and clothes, and DO NOT breathe vapors. Cleaning compound fumes or vapors can take the place of air and may become a cancer producing agent. DO NOT use near open flame or excessive heat. The compound's boiling point is 114°F (46° C). If you become dizzy while using cleaning compound, immediately get fresh air and medical help. If compound contacts eyes, immediately wash your eyes with water and get medical aid.
- Denatured alcohol is highly flammable and poisonous. Drinking this alcohol can cause blindness and death. Avoid inhaling its fumes. Keep away from open flames. Failure to follow this warning may result in serious injury or death to personnel.

WARNING**COMPRESSED AIR**

Compressed air used for cleaning or drying purposes, or for clearing restrictions, should never exceed 30 psi (207 kPa). Wear protective clothing (goggles/shield, gloves, etc.) and use caution to avoid injury to personnel.

WARNING**ELECTRICAL SYSTEM**

- When troubleshooting an electrical malfunction or performing electrical maintenance, ALWAYS disconnect the battery cables. Failure to do so may result in injury or death due to electric shock.
- Battery acid (electrolyte) is extremely dangerous. Use care when removing battery caps. Serious injury to personnel may result if battery acid contacts skin or eyes.

WARNING

HANDLING HEAVY COMPONENTS

Use extreme caution when handling heavy parts. Lifting device is required when parts weigh over 50 lb (23 kg) for a single person lift, over 100 lb (45 kg) for a two person lift, and over 150 lb (68 kg) for a three or more person lift. Keep clear of heavy parts supported only by lifting device. Failure to follow this warning may cause serious injury or death to personnel.

WARNING

LIVE STEAM

Avoid contact with live steam. Live steam can burn skin, cause blindness, and other serious injury. Be sure to wear protective apron, gloves, and safety goggles when using live steam.

WARNING

NBC HAZARD

If NBC exposure is suspected, all engine air cleaner air filter media should be handled by personnel wearing protective equipment. Consult your NBC Officer or NBC NCO for appropriate handling or disposal procedures.

c/(d Blank)

**DIRECT SUPPORT AND GENERAL SUPPORT
MAINTENANCE MANUAL**

FOR

**TRACTOR, WHEELED,
DED, LOADER BACKHOE:
WITH HYDRAULIC IMPACT TOOL AND
WITH HYDRAULIC EARTH AUGER ATTACHMENT
JOHN DEERE MODEL JD410 (CCE)
WITH BUCKET, IMPACTOR,
AND EARTH DRILL
(NSN 2420-00-567-0135)**

REPORTING ERRORS AND RECOMMENDING IMPROVEMENTS

You can help improve this manual. If you find any mistakes or if you know of a way to improve the procedures, please let us know. Mail your letter, DA Form 2028 (Recommended Changes to Publications and Blank Forms), or DA Form 2028-2, located in the back of this manual, direct to: Commander, U.S. Army Tank-Automotive Command, ATTN: AMSTA-MB, Warren, MI 48397-5000. A reply will be furnished to you.

TABLE OF CONTENTS

	Page
How To Use This Manual	iii
CHAPTER 1 INTRODUCTION	
Section I. General Information	1-1
Section II. Equipment Description and Data	1-2
Section III. Repair Parts; Special Tools; Test, Measurement, and Diagnostic Equipment (TMDE); and Support Equipment.....	1-3
Section IV. General Maintenance Instructions	1-4
CHAPTER 2 TROUBLESHOOTING PROCEDURES	2-1
CHAPTER 3 ENGINE ASSEMBLY MAINTENANCE	
Section I. Engine Assembly Maintenance	3-1
Section II. Lubrication System Maintenance	3-115

*This manual and LO 5-2420-222-12, TM 5-2420-222-10, TM 5-2420-222-20-1, -20-2, -20-3, TM 5-2420-222-20P, and TM 5-2420-222-34P supersede TM 5-2420-222-14&P-1, dated 1 January 1987, and TM 5-2420-222-14&P-2, dated 1 November 1 1986, including all changes.

Approved for public release; distribution is unlimited.

TABLE OF CONTENTS (CON'T)

	Page
CHAPTER 4 CLUTCH ASSEMBLY MAINTENANCE	4-1
CHAPTER 5 FUEL SYSTEM MAINTENANCE	5-1
CHAPTER 6 COOLING SYSTEM MAINTENANCE	6-1
CHAPTER 7 ELECTRICAL SYSTEM MAINTENANCE	7-1
CHAPTER 8 TRANSMISSION MAINTENANCE	8-1
CHAPTER 9 AXLE MAINTENANCE	
Section I. Front Axle Maintenance	9-1
Section II. Rear Axle Maintenance	9-10
CHAPTER 10 BRAKE SYSTEM MAINTENANCE	10-1
CHAPTER 11 STEERING SYSTEM MAINTENANCE	11-1
CHAPTER 12 FRAME MAINTENANCE	12-1
CHAPTER 13 BODY AND ACCESSORIES MAINTENANCE	13-1
CHAPTER 14 HYDRAULIC SYSTEM MAINTENANCE	14-1
CHAPTER 15 CRANES, SHOVELS, AND EARTHMOVING EQUIPMENT COMPONENTS MAINTENANCE	
Section I. Backhoe Assembly Maintenance	15-1
Section II. Loader Assembly Maintenance	15-22
CHAPTER 16 PARTS PECULIAR MAINTENANCE	16-1
APPENDIX A REFERENCES	A-1
APPENDIX B EXPENDABLE/DURABLE SUPPLIES AND MATERIALS LIST	B-1
APPENDIX C ILLUSTRATED LIST OF MANUFACTURED ITEMS	C-1
APPENDIX D TORQUE LIMITS	D-1
INDEX	Index-1

HOW TO USE THIS MANUAL

This manual is designed to help maintain the John Deere Model JD410 Wheeled Tractor Loader Backhoe. This manual describes in detail the Direct Support and General Support Maintenance prescribed by the Maintenance Allocation Chart (see TM 5-2420-222-20) and Source, Maintenance, and Recoverability (SMR) Codes (see TM 5-2420-222-34P).

FEATURES OF THIS MANUAL:

- Bleed-to-edge indicators on the cover and on the edge of the applicable manual pages provide quick access to chapters most often used.
- A table of contents is provided for all chapters and sections.
- WARNINGS, CAUTIONS, NOTES, subject headings, and other important information are highlighted in bold print as visual aids.
- Statements and words of particular importance are printed in capital letters to create emphasis.
- Instructions are located together with illustrations that show the specific task or, which the technician is working
- An alphabetical index is provided at the end of the manual to assist in locating information not readily found in the table of contents.
- Technical instructions include metric units in addition to standard units. A metric conversion chart is provided on the inside back cover.

FOLLOW THESE GUIDELINES WHEN YOU USE THE MANUAL:

- Read through this manual and become familiar with its contents before proceeding to specific maintenance warning summary is provided at the beginning of this manual and should be read before performing any maintenance tasks.
- In the actual maintenance tasks, follow all WARNINGS, CAUTIONS, and NOTES. These are given immediately preceding the procedural steps to which they apply. If these instructions are not followed or care is not taken, injury to personnel or equipment damage may result.
- Within a chapter, section, or paragraph, headings are used to help group the material and assist in quickly finding tasks. Read all preliminary information found at the beginning of each task. After completing a task, ALWAYS perform the follow-on maintenance at the end of the task.

CHAPTER 1
INTRODUCTION

Section I. GENERAL INFORMATION

Paragraph Number	Paragraph Title	Page Number
1-1	Scope	1-1
1-2	Maintenance Forms, Records, and Reports	1-1
1-3	Destruction of Army Materiel To Prevent Enemy Use.....	1-1
1-4	Reporting Equipment Improvement Recommendations (EIRs)	1-1

1-1. SCOPE.

This manual describes the troubleshooting and maintenance of the John Deere Model JD410 Wheeled Tractor Loader Backhoe for Direct Support and General Support Maintenance mechanics.

1-2. MAINTENANCE FORMS, RECORDS, AND REPORTS.

Department of the Army forms and procedures used for equipment maintenance will be those prescribed by DA Pam 738-750, The Army Maintenance Management System (TAMMS).

1-3. DESTRUCTION OF ARMY MATERIEL TO PREVENT ENEMY USE.

For destruction of Army materiel to prevent enemy use, refer to TM 750-244-3.

1-4. REPORTING EQUIPMENT IMPROVEMENT RECOMMENDATIONS (EIRs).

If your loader backhoe needs improvement, let us know. Send us an EIR. You, the user, are the only one who can tell us what you don't like about your equipment. Let us know why you don't like the design. Put it on an SF Form 368 (Product Quality Deficiency Report). Mail it to us at: Commander, U.S. Army Tank-Automotive Command, ATTN: AMSTA-MP, Warren, MI 48397-5000. We'll send you a reply.

Section II. EQUIPMENT DESCRIPTION AND DATA

Paragraph Number	Paragraph Title	Page Number
1-5	Differences Between Models	1-2
1-6	Equipment Data	1-2

1-5. DIFFERENCES BETWEEN MODELS.

WARNING

Pay close attention to serial numbers when performing maintenance on this equipment. Installation of Incorrect part numbers may result in injury to personnel or damage to equipment.

Although all loader backhoes covered in this manual have the same model number, there are differences in configuration depending on the loader backhoe serial number. The two serial number breaks are 235786-235999 and 319995-342573. These two configurations differ primarily in transmission design and hydraulic line routing. Throughout this manual, where differences in configuration or equipment affect the maintenance, they are shown in detail. If the differences are minor or obvious, such as differences in exact appearance or location, and maintenance is not affected, typical equipment is shown.

1-6. EQUIPMENT DATA.

Refer to TM 5-2420-222-10 for information on loader backhoe identification and data plates, major components, and end item and component specifications.

**Section III. REPAIR PARTS; SPECIAL TOOLS;
TEST, MEASUREMENT, AND DIAGNOSTIC EQUIPMENT (TMDE);
AND SUPPORT EQUIPMENT**

Paragraph Number	Paragraph Title	Page Number
1-7	Common Tools	1-3
1-8	Special Tools; Test, Measurement, and Diagnostic Equipment (TMDE); and Support Equipment.....	1-3
1-9	Repair Parts	1-3

1-7. COMMON TOOLS.

For authorized common tools and test equipment, refer to the Modified Table of Organization and Equipment (MTOE) applicable to your loader backhoe.

1-8. SPECIALTOOLS; TEST, MEASUREMENT, AND DIAGNOSTIC EQUIPMENT (TMDE); AND SUPPORT EQUIPMENT.

Special tools required for maintenance of the loader backhoe are listed in TM 5-2420-222-34P. Refer to the Maintenance Allocation Chart (MAC) in TM 5-2420-222-20 for a description of necessary tools, TMDE, and support equipment. Refer to Appendix C, Illustrated List of Manufactured Items, in this manual for a description of fabricated tools.

1-9. REPAIR PARTS.

Repair parts for the Direct Support and General Support Maintenance of the loader backhoe are listed and illustrated in TM 5-2420-222-34P.

Section IV. GENERAL MAINTENANCE INSTRUCTIONS

Paragraph Number	Paragraph Title	Page Number
1-10	General.....	1-4
1-11	Work Safety.....	1-5
1-12	Cleaning Instructions.....	1-5
1-13	Preservation of Parts.....	1-6
1-14	Painting.....	1-6
1-15	Inspection Instructions.....	1-6
1-16	Bearing Clearance Gage.....	1-7
1-17	Service Replacement Kits.....	1-8
1-18	Tagging Parts.....	1-8
1-19	Soldering.....	1-9
1-20	Heat Shrink Tubing.....	1-9
1-21	Wire Terminal Lug and Connector Replacement.....	1-10
1-22	Wire Replacement.....	1-10
1-23	Wiring Harness Connector Repair and Replacement.....	1-11
1-24	Electrical Ground Points.....	1-12
1-25	Lines and Ports.....	1-13
1-26	Antiseizing Tape.....	1-13
1-27	Tubes and Compression Fittings.....	1-13
1-28	Lockwire.....	1-14
1-29	Fluid Disposal.....	1-15

1.10. GENERAL.

a. These general maintenance instructions contain general shop practices and specific methods you must be familiar with to properly maintain your loader backhoe. You should read and understand these practices and methods before performing any Direct Support and General Support Maintenance procedures.

b. Before beginning a task, find out how much repair, modification, or replacement is needed to fix the equipment. Sometimes the reason for equipment failure can be seen right away and complete teardown is not necessary. Disassemble equipment only as far as necessary to repair or replace damaged parts.

c. In some cases, a part may be damaged by removal. If the part appears to be good, and other parts behind it are not defective, leave it on and continue with the procedure. Here are a few simple rules:

- (1) Do not remove dowel pins or studs unless loose, bent, broken, or otherwise damaged.
- (2) Do not remove bearings or bushings unless damaged. If you need to remove them to access parts behind, pull bearings and bushings out carefully.
- (3) Replace all gaskets, lockwashers, seals, cotter pins, and preformed packings.

d. The following "Initial Setup" information applies to all procedures:

- (1) Resources are not listed unless they apply to the procedure.
- (2) "Personnel Required" is listed only if more than one mechanic is required to complete the task.

1-10. GENERAL (Con't).

e. All tags and forms attached to equipment must be checked to learn the reason for removal of equipment from service. Modification Work Orders (MWO) and Technical Bulletins (TB) must also be checked for equipment changes and updates.

1-11. WORK SAFETY.

a. Before beginning a procedure, think about the safety risks and hazards to yourself and others. Wear protective gear such as safety goggles or lenses, safety shoes, rubber apron, or gloves.

b. Immediately clean up spilled fluids to avoid slipping.

c. When lifting heavy parts, have someone help you. Ensure that lifting equipment or jack is working properly, that it meets weight requirement of part being lifted, and that it is securely fastened to part.

d. Always use power tools carefully.

e. Observe all WARNINGS and CAUTIONS.

1-12. CLEANING INSTRUCTIONS.

WARNING

Improper cleaning methods and use of unauthorized cleaning liquids or solvents can injure personnel and damage equipment. To prevent this, refer to TM 9-247 for further instructions.

a. **General.** Cleaning instructions will be the same for the majority of parts and components which make up the loader backhoe. The following applies to all cleaning operations:

(1) Clean all parts before inspection, after repair, and before assembly.

(2) Keep hands free of grease which can collect dust, dirt, and grit.

(3) After cleaning, all parts should be covered or wrapped to protect them from dust and dirt. Parts that are subject to rust should be lightly oiled.

b. **Steam Cleaning.**

(1) Before steam cleaning loader backhoe, protect all electrical equipment which could be damaged by steam or moisture.

(2) Place disassembled parts in a suitable container to steam clean. Parts that are subject to rust should be dried and lightly oiled after cleaning.

c. **Castings, Forgings, and Machined Metal Parts.**

WARNING

Dry cleaning solvent, P-D-680, is toxic and flammable. Always wear protective goggles and gloves, and use only in a well-ventilated area. Avoid contact with skin, eyes, and clothes, and DO NOT breathe vapors. DO NOT use near open flame or excessive heat. The solvent's flash point is 100°F-138°F (38°C-59°C). If you become dizzy while using cleaning solvent, immediately get fresh air and medical help. If solvent contacts eyes, immediately wash your eyes and get medical aid.

(1) Clean inner and outer surfaces with dry cleaning solvent (Item 31, Appendix B).

1-12. CLEANING INSTRUCTIONS (Con't).

- (2) Remove grease and accumulated deposits with a scrub brush (Item 3, Appendix B).

WARNING

Compressed air used for cleaning or drying purposes, or for clearing restrictions, should never exceed 30 psi (207 kPa). Wear protective clothing (goggles/shield, gloves, etc.) and use caution to avoid injury to personnel.

- (3) Clear all threaded holes with compressed air to remove dirt and cleaning fluids.

CAUTION

Do not wash oil seals, electrical cables, and flexible hoses with dry cleaning solvent or mineral spirits. Serious damage or destruction of material will result.

- d. **Oil Seals, Electrical Cables, and Flexible Hoses.** Wash oil seals, electrical cables, and flexible hoses with a solution of detergent (Item 13, Appendix B) and water and wipe dry.
- e. **Bearings.** Clean bearings in accordance with TM 9-214.
- f. **General Cleaning Covered by Other Manuals.**
- (1) TB 43-0212, Purging, Cleaning and Coating Interior Ferrous and Terne Sheet Vehicle Fuel Tanks.
- (2) TB 750-1047, Elimination of Combustibles from Interiors of Metal or Plastic Gasoline and Diesel Fuel Tanks.
- (3) TM 9-247, Materials Used for Cleaning, Preserving, Abrading, and Cementing Ordnance Materiel and Related Items Including Chemicals.

1-13. PRESERVATION OF PARTS.

Unpainted metal parts that will not be installed immediately after cleaning may be covered with a thin coat of engine oil (Item 25, Appendix B).

1-14. PAINTING.

On painted areas where paint has been removed, paint in accordance with procedures outlined in TM 43-0139 and TB 43-0209. For camouflage painting instructions refer to TC 5-200.

1-15. INSPECTION INSTRUCTIONS.

NOTE

All damaged areas should be marked for repair or replacement.

- a. All components and parts must be carefully checked to determine if they are serviceable for use, can be repaired, or must be scrapped.
- b. Inspect drilled and tapped (threaded) holes for the following:
- (1) Wear, distortion, cracks, and any other damage in or around holes.
- (2) Threaded areas for wear distortion (stretching) and evidence of cross-threading.

1-15. INSPECTION INSTRUCTIONS (Con't).

- c. Inspect metal lines, flexible lines (hoses), and metal fittings and connectors for the following:
 - (1) Metal lines for sharp kinks, cracks, bad bends, and dents.
 - (2) Flexible lines for fraying, evidence of leakage, and loose metal fittings or connectors.
 - (3) Metal fittings and connectors for thread damage and worn or rounded hex heads.
- d. Inspect castings, forgings, and machined metal parts for the following:
 - (1) Machined surfaces for nicks, burrs, raised metal wear, and other damage.
 - (2) Inner and outer surfaces for breaks and cracks.
- e. Inspect bearings in accordance with TM 9-214.

1-16. BEARING CLEARANCE GAGE.

- a. A soft plastic bearing clearance gage (plastigage) squeezed between parts such as a crankshaft journal and a connecting rod or main bearing may be used to measure clearance between them.
- b. The bearing clearance gage is a specially molded plastic "wire" and is available in three measuring ranges and colors:

PG-1 (Green)	0.001-0.003 in. (0.0254-0.0762 mm) (Item 19, Appendix B)
PR-1 (Red)	0.002-0.006 in. (0.0508-0.1524 mm) (Item 20, Appendix B)
PB-1 (Blue)	0.004-0.009 in. (0.1016-0.2286 mm) (Item 18, Appendix B)

- c. Check bearing clearance as follows:
 - (1) Remove bearing cap and wipe oil from bearing shell and crankshaft journal.

NOTE

When checking main bearing clearance with engine in position and main bearing caps supporting weight of crankshaft and flywheel, a bad reading may result due to weight of crankshaft and flywheel. To avoid a bad reading, support weight with a Jack placed under counterweight next to bearing being checked.

- (2) Place bearing clearance gage full width of bearing shell, about y in. (6 mm) off-center.
- (3) Rotate crankshaft about 300 from bottom dead center (BDC) and install assembled bearing shell and cap. Tighten screws to specified torque.

1-16. BEARING CLEARANCE GAGE (Con't)

(4) Remove bearing shell and cap. Flattened gage will remain stuck to either bearing shell or crankshaft.

(5) Compare width of flattened gage at its widest point with graduations on envelope. Number within graduation on envelope indicates bearing clearance in thousandths of an inch.

(6) Taper may be indicated when one end of flattened gage is wider than the other. Measure each end of gage; the difference between readings is the approximate amount of taper.

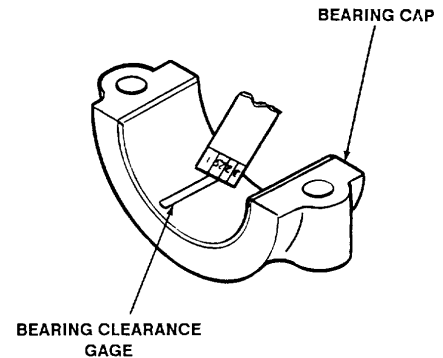
**1-17. SERVICE REPLACEMENT KITS.**

Many service replacement parts are available in various undersize and/or oversize, as well as standard sizes. Service kits for reconditioning certain parts and service sets which include all parts necessary to complete task are also available.

1-18. TAGGING PARTS.

a. Use marker tags (Item 32, Appendix B) to identify all electrical wires, hydraulic, fuel, oil, and coolant lines, and any other parts which may be hard to identify or replace later. Fasten tags to parts during removal by wrapping wire fasteners around or through parts and twisting ends together. Position tags to be out of the way during cleaning, inspection, and repair. Mark tags with a pencil, pen, or marker.

b. Whenever possible, identify electrical wires with number of terminal or wire to which it connects. If no markings can be found, tag both wires or wire and terminal, and use same identifying mark for both. If you cannot tag wire because it must fit through small hole or you cannot reach it, write down description of wire and the point to which it connects or draw a simple diagram on paper. Be sure to write down enough information so you will be able to connect wires properly during assembly. If you need to identify loose wire, look for identifying numbers near end of wire, stamped on a permanent metal tag. Compare this number to wire numbers on appropriate electrical schematic in TM 5-2420-222-20.

c. Identify hydraulic, fuel, oil, and coolant lines whenever you are taking off more than one line at the same time. Mark tags with points to which lines and hoses must be connected. For example: "Bulkhead adapter to scarifier cylinder tube and adapter" might be written on tag for hydraulic hose. If it is not obvious which end of a line goes where, tag each end of line.

d. Identify and tag other parts as required by name and installed location.

TA701214

1-19. SOLDERING.

WARNING

Cleaning compound, trichlorotrifluoroethane, for electrical parts is toxic and flammable, and reacts violently with aluminum, titanium, barium, lithium, samarium, sodium, and potassium. Always wear protective goggles and rubber gloves, and use only in a well-ventilated area. DO NOT wear jewelry while using cleaning compound. Avoid contact with skin, eyes, and clothes, and DO NOT breathe vapors. Cleaning compound fumes or vapors can take the place of air and may become a cancer producing agent. DO NOT use near open flame or excessive heat. The compound's boiling point is 114°F (46°C). If you become dizzy while using cleaning compound, immediately get fresh air and medical help. If compound contacts eyes, immediately wash your eyes with water and get medical aid.

CAUTION

Use low-wattage soldering gun when soldering electrical wires, connectors, terminal lugs, and receptacles. High-wattage soldering guns may damage parts by overheating them.

a. Solder connection must be bright and clean before soldering. Take off dirt and grease with trichlorotrifluoroethane (Item 40, Appendix B). Solder used must be tin alloy (Item 30, Appendix B) with rosin flux (Item 16, Appendix B). All wires, parts, and soldering gun must be pretinned for good connection and maximum transfer of heat.

b. To prevent overheating damage to electrical parts when soldering and unsoldering connections, hold bare wire, lead, or terminal lug close to soldering point with long roundnose pliers. Pliers act as heatsink and absorb excess heat.

WARNING

Cleaning compound, trichlorotrifluoroethane, for electrical parts is toxic and flammable, and reacts violently with aluminum, titanium, barium, lithium, samarium, sodium, and potassium. Always wear protective goggles and rubber gloves, and use only in a well-ventilated area. DO NOT wear Jewelry while using cleaning compound. Avoid contact with skin, eyes, and clothes, and DO NOT breathe vapors. Cleaning compound fumes or vapors can take the place of air and may become a cancer producing agent. DO NOT use near open flame or excessive heat. The compound's boiling point is 114°F (46°C). If you become dizzy while using cleaning compound, immediately get fresh air and medical help. If compound contacts eyes, immediately wash your eyes with water and get medical aid.

c. Clean all solder joints with a scrub brush (Item 3, Appendix B) and electrical parts trichlorotrifluoroethane (Item 40, Appendix B) after soldering to get a bright clean surface.

1-20. HEAT SHRINK TUBING.

Use heat shrink tubing (Item 41, Appendix B) to insulate soldered and crimped electrical connections as follows:

- (1) Cut desired length of new tubing twice the diameter of connection to be covered.
- (2) Slide tubing onto wire and out of the way before making connection.

1-20. HEAT SHRINK TUBING (Con't).

- (3) After making electrical connection, slide tubing into place over it.

WARNING

Do not touch heat shrink tubing for at least 30 seconds after heating. Tubing is hot and can burn you.

- (4) Hold heat gun 4-5 in. (10.2-12.7 cm) away from tubing and apply heat for about 30 seconds. Stop applying heat as soon as tubing forms to shape of connection.

1-21. WIRE TERMINAL LUG AND CONNECTOR REPLACEMENT.

WARNING

Although battery disconnect switch must be on and battery ground cable connected to test electrical circuit voltage, turn off battery disconnect switch or disconnect battery ground cable before doing resistance tests or replacing parts. This will prevent electrical shock and damage to parts and equipment.

- a. Cut off damaged terminal lug or connector with diagonal-cutting pliers.
- b. Slide new length of heat shrink tubing (Item 41, Appendix B) over wire if necessary.
- c. Using wire stripper, strip enough insulation from wire to allow bare wire to go all the way into hole in terminal lug or connector.
- d. Select proper terminal lug or connector for wire size and terminal stud or other mating connector.
- e. Insert bare end of wire all the way into terminal lug or connector.
- f. Crimp or solder terminal lug or connector to wire. Ensure that connection is tight.
- g. If heat shrink tubing (Item 41, Appendix B) is used, slide tubing over connection and shrink in place (see paragraph 1-20).

1-22. WIRE REPLACEMENT.

WARNING

Although battery disconnect switch must be on and battery ground cable connected to test electrical circuit voltage, turn off battery disconnect switch or disconnect battery ground cable before doing resistance tests or replacing parts. This will prevent electrical shock and damage to parts and equipment.

- a. If terminal lugs or connectors of wire to be replaced are covered with heat shrink tubing, cut off tubing using knife.
- b. If solder type terminal lug is in good condition, it can be unsoldered and reused.
- c. Unsolder wires from soldered splices and terminal connections.

1-22. WIRE REPLACEMENT (Con't).

- d. Cut new wire of same gage and type as wire being replaced to desired length using diagonal-cutting pliers.

NOTE

Always use heat shrink tubing around wire splices or wrap them with electrical tape.

e. Slide new length of heat shrink tubing (Item 41, Appendix B) onto ends of new wire. If desired. If tubing is not available, use electrical tape (Item 36, Appendix B).

f. Connect terminal lugs or connectors to wire by soldering or crimping as required. Ensure that connections are tight.

g. To splice wires together, twist and tie end strands of each wire separately. After tinned ends have cooled, twist both ends together and reheat with soldering gun to fuse ends together.

h. If heat shrink tubing (Item 41, Appendix B) is used, slide tubing over connections and shrink in place (see paragraph 1-20).

1-23. WIRING HARNESS CONNECTOR REPAIR AND REPLACEMENT.

All wiring harness connectors are of similar design and are repaired and replaced the same way. To repair or replace individual wires and pins, mating connectors must be disconnected, but it may not be necessary to remove connectors from their mounting points. Repair or replace wiring harness connectors as follows:

WARNING

Although battery disconnect switch must be on and battery ground cable connected to test electrical circuit voltage, turn off battery disconnect switch or disconnect battery ground cable before doing resistance tests or replacing parts. This will prevent electrical shock and damage to parts and equipment.

- (1) Unscrew retaining nut from connector and push back out of the way on wiring harness.
- (2) Pull retainer out of connector and slide back on wires to expose back of pins.
- (3) If replacing more than one wire or pin, tag each wire before removal with letter shown on face of connector.
- (4) If replacing entire connector:
 - (a) Using soldering gun, unsolder each wire from pin.
 - (b) Discard defective connector.
- (5) If replacing individual wire or pin:
 - (a) Using long roundnose pliers, pull pin out of connector.
 - (b) Using soldering gun and long roundnose pliers, unsolder wire from pin.
- (6) Pull wire(s) out of holes in retainer and retaining nut.
- (7) Replace defective parts as required.

1-23. WIRING HARNESS CONNECTOR REPAIR AND REPLACEMENT (Con't).

- (8) Insert wire(s) through holes in retaining nut and retainer.
- (9) Using soldering gun and long roundnose pliers, solder wire(s) onto pins. Ensure that each connection is solid.
- (10) Using long roundnose pliers, push pin(s) into proper hole(s) of connector.
- (11) Remove tags from wires.
- (12) Push retainer into connector. Install retaining nut onto connector and tighten.

1-24. ELECTRICAL GROUND POINTS.

Many electrical problems are the result of poor ground connections. You can ensure that ground connections are good by performing the following steps:

WARNING

Although battery disconnect switch must be on and battery ground cable connected to test electrical circuit voltage, turn off battery disconnect switch or disconnect battery ground cable before doing resistance tests or replacing parts. This will prevent electrical shock and damage to parts and equipment.

- (1) Remove hardware connecting ground cable terminal lug to ground point.

WARNING

Cleaning compound, trichlorotrifluoroethane, for electrical parts is toxic and flammable, and reacts violently with aluminum, titanium, barium, lithium, samarium, sodium, and potassium. Always wear protective goggles and rubber gloves, and use only in a well-ventilated area. DO NOT wear Jewelry while using cleaning compound. Avoid contact with skin, eyes, and clothes, and DO NOT breathe vapors. Cleaning compound fumes or vapors can take the place of air and may become a cancer producing agent. DO NOT use near open flame or excessive heat. The compound's boiling point is 114°F (46°C). If you become dizzy while using cleaning compound, immediately get fresh air and medical help. If compound contacts eyes, immediately wash your eyes with water and get medical aid.

- (2) Clean mounting hardware, ground cable terminal lugs, and ground point with trichlorotrifluoroethane (Item 40, Appendix B) and a scrub brush (Item 3, Appendix B).
- (3) Remove any rust with a wire brush (Item 4, Appendix B) and crocus cloth (Item 7, Appendix B).
- (4) Look for cracks, loose terminal lugs, and stripped threads. Replace any defective parts.
- (5) Install hardware connecting ground cable terminal lug to ground point. Ensure that all hardware is tight.

1-25. LINES AND PORTS.

To keep dirt from contaminating fluid systems when removing and installing hydraulic, fuel, oil, and coolant lines, perform the following steps:

- (1) Clean fittings and surrounding area before disconnecting lines.
- (2) Cover, cap, plug, or tape lines and ports after disconnecting lines. When these are not available, use hand-carved wooden plugs, clean rags (Item 28, Appendix B), duct tape (Item 35, Appendix B), or other similar materials to prevent dirt from entering system.
- (3) Ensure that new and used parts are clean before installing.
- (4) Wait to uncover, uncap, unplug, or remove tape from lines and ports until just before installing lines.

1-26. ANTISEIZING TAPE.

Antiseizing tape (Item 34, Appendix B) may be used to keep connections from leaking whenever you are connecting fuel, oil, and hydraulic system lines and fittings without compression sleeves or packings as follows:

- (1) Ensure that threads are clean and dry.
- (2) Start tape one or two threads from small or leading edge of fitting, joining tape together with an overlap of about X in. (3 mm) for fittings with fine threads. For fittings with coarse threads, tape should be wrapped around threads two or three times.
- (3) Wrap tape tightly in same direction as you tighten a nut. Tape must be pressed into threads without cutting or ripping

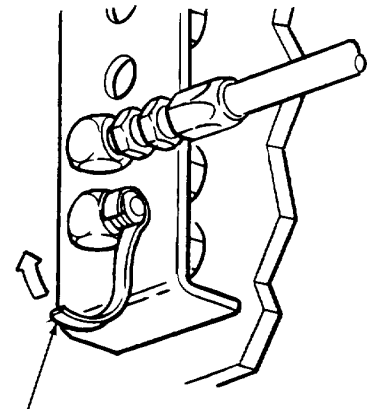

ANTISEIZING TAPE

CAUTION

Do not exceed specified torque or use power tools to tighten fittings taped with antiseizing tape. Overtightening could damage fitting threads and cause connection to leak.

- (4) Using hand tools, tighten fittings to specified torque.

1-27. TUBES AND COMPRESSION FITTINGS.

a. Tubes with inverted nuts and compression fittings are designed for one-time assembly. Once assembled, they must be replaced as a unit if any parts are found defective. Used parts may not seal properly when used with new ones.

- b. Used tube assemblies in good condition can be installed to their original location without leaking.

TA701215

1-27. TUBES AND COMPRESSION FITTING

c. Assemble new tubes, compression sleeves, and inverted nuts as follows:

- (1) Slide inverted nut onto end of tube.
- (2) Slide compression sleeve onto end of tube.
- (3) Repeat steps (1) and (2) for other end of tube as required.

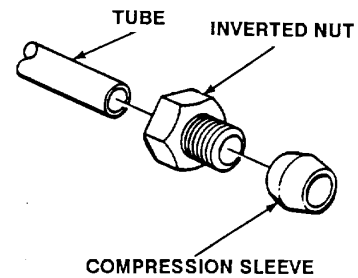

d. Install new tube assemblies as follows:

- (1) Insert end of tube as far as it will go into fitting to which tube is being installed.
- (2) Install inverted nut into fitting and tighten it against compression sleeve with open end wrench. Compression sleeve will clamp down around tube and conform to internal surface of fitting and inverted nut.
- (3) Repeat steps (1) and (2) for other end of tube as required.

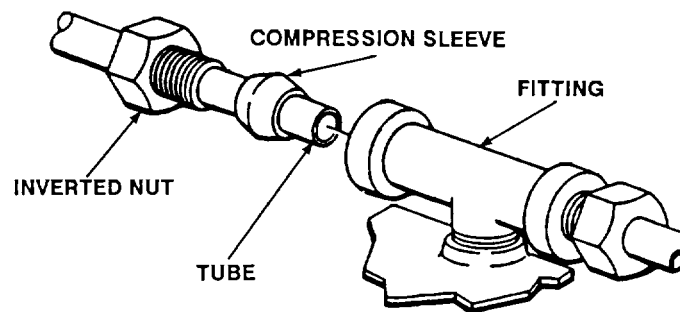

1-28. LOCKWIRE.

- a. Always use nonelectrical wire (Item 44, Appendix B).
- b. Drilled head screws and bolts usually do not require lockwiring if they are installed with self-locking nuts or lockwashers.
- c. Three screws or bolts are the maximum number that may be lockwired in a series when they are spaced 4-6 in. (10.2-15.2 cm) apart. The maximum number of closely-spaced multiple groups of screws or bolts to be lockwired is limited to the number of units that can be lockwired with a 24 in. (61.0 cm) length of wire.
- d. Do not secure screws, bolts, or fittings which are spaced more than 6 in. (15.2 cm) apart. Lockwire these fasteners to tiepoints 6 in. (15.2 cm) or less away.

TA701216

1-28. LOCKWIRE (Con't).

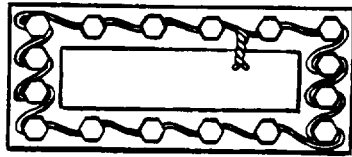

SMALL SCREWS IN CLOSELY SPACED, CLOSED GEOMETRICAL PATTERN – SINGLE WIRE METHOD

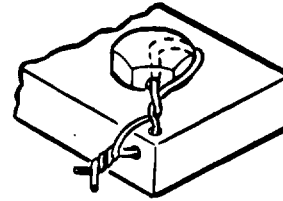

SINGLE FASTENER APPLICATION – DOUBLE TWIST METHOD

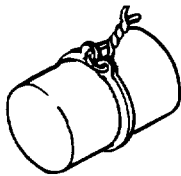

EXTERNAL RETAINER RING – SINGLE WIRE METHOD

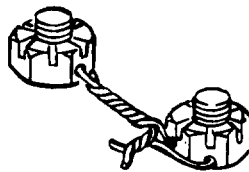

CASTELLATED NUTS ON UNDRILLED STUDS – DOUBLE TWIST METHOD

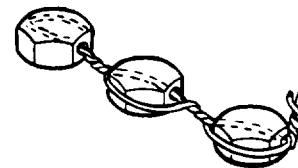

MULTIPLE FASTENER APPLICATION – DOUBLE TWIST METHOD

e. Lockwire parts so that tension will be on lockwire when parts tend to loosen. Lockwire should be installed and twisted tightly so that loop around head stays down and does not come up over head of screw or bolt. This does not apply to castellated nuts when slot is close to top of nuts; wire is more secure when made to pass along the side of stud. Ensure that lockwire is tight but not overstressed.

f. Make pigtail of $\frac{1}{8}$ in. (6.4-12.7 mm) at end of lockwire. Bend pigtail down so it will not become a snag.

g. When lockwiring castellated nuts, tighten nut to low side of torque range, then continue tightening until slot lines up with hole.

h. In blind tapped hole application of bolts or castellated nuts or studs, lockwire as shown.

1-29. FLUID DISPOSAL.

Dispose of contaminated drained fluids in accordance with the Standing Operating Procedures (SOP) of your unit.

TA701217

**CHAPTER 2
TROUBLESHOOTING PROCEDURES**

Paragraph Number	Paragraph Title	Page Number
2-1	General.....	2-1
2-2	Explanation of Columns	2-1
2-3	Troubleshooting Symptom Index.....	2-2
table 2-1.	Troubleshooting.....	2-3

2-1. GENERAL.

- a. This section provides information for identifying and correcting malfunctions which may develop while operating your loader backhoe.
- b. The Troubleshooting Symptom Index in paragraph 2-3 lists common malfunctions which may occur and refers you to the proper page in Table 2-1 for a troubleshooting procedure.
- c. If you are unsure of the location of an item mentioned in troubleshooting, refer to the maintenance task where the item is replaced.
- d. Before performing troubleshooting, read and follow all safety instructions found in the Warning Summary at the front of this manual.
- e. This section cannot list all malfunctions that may occur, nor all tests or inspections and corrective actions. If a malfunction is not listed, or is not corrected by the listed corrective actions, notify your supervisor.
- f. When troubleshooting a malfunction:
 - (1) Locate the symptom or symptoms in paragraph 2-3 that best describe the malfunction.
 - (2) Turn to the page in Table 2-1 where the troubleshooting procedures for the malfunction in question are described. Headings at top of each page show how each troubleshooting procedure is organized: MALFUNCTION, TEST OR INSPECTION (in step number order), and CORRECTIVE ACTION.
 - (3) Perform each step in the order listed until the malfunction is corrected. DO NOT perform any maintenance task unless the troubleshooting procedure tells you to do so.

2-2. EXPLANATION OF COLUMNS.

The columns in Table 2-1 are defined as follows:

- (1) **MALFUNCTION.** A visual or operational indication that something is wrong with the loader backhoe.
- (2) **TEST OR INSPECTION.** A procedure to isolate the problem in a component or system.
- (3) **CORRECTIVE ACTION.** A procedure to correct the problem.

2-3. TROUBLESHOOTING SYMPTOM INDEX.

	Troubleshooting Procedure Page
BRAKES	
Do Not:	
Hold Loader Backhoe	2-11
Stop Loader Backhoe	2-11
Excessive Pedal Leak-down	2-10
CLUTCH ASSEMBLY	
Drags	2-8
Noisy	2-7
Pedal Vibrates.....	2-7
Slips	2-7
ENGINE ASSEMBLY	
Exhaust Smokes Excessively	2-3
Hard to Start.....	2-3
Noisy	2-4
Oil Pressure Too Low	2-4
Overheats	2-5
Performs Poorly	2-5
Speed Is Erratic	2-4
Starts But Will Not Run	2-3
Uses Too Much Oil	2-6
Will Not Start	2-3
HYDRAULIC SYSTEM	
Cylinder Fails to Work.....	2-12
Hydraulic Fluid Foams	2-12
REAR AXLE HOUSING	
Noisy	2-10
STEERING	
Continuous Steering Wheel Rotation and No Response.....	2-11
No Response When Steering Wheel is Turned Slowly	2-11
Wheel Does Not Center.....	2-11
Wrong Response to Steering.....	2-11

2-3. TROUBLESHOOTING SYMPTOM INDEX (Cont'd).

	Troubleshooting Procedure Page
TRANSMISSION	
Brake Slips Under Load.....	2-10
Clutch Slips Under Load.....	2-10
Differential Will Not Lock	2-9
Excessive Gear Clash When Shifting.....	2-9
Jumps When Engaged	2-10
No Differential Action.....	2-9
Noisy	2-9
Shifts:	
Too Fast.....	2-8
Too Slowly.....	2-8

Table 2-1. Troubleshooting.

**MALFUNCTION
TEST OR INSPECTION
CORRECTIVE ACTION**

ENGINE ASSEMBLY

1. ENGINE IS HARD TO START/WILL NOT START.

Step 1. Perform engine assembly vacuum test (see paragraph 3-2).

Replace air filter (see TM 5-2420-222-20).

Step 2. Perform engine assembly compression test (see paragraph 3-1).

Repair as required.

Step 3. Start engine to see if fuel metering pump is working properly (see TM 5-2420-222-10).

Replace fuel metering pump (see paragraph 5-2).

2. ENGINE STARTS BUT WILL NOT RUN.

Perform engine assembly vacuum test (see paragraph 3-2).

Replace air filter (see TM 5-2420-222-20).

3. EXHAUST SMOKES EXCESSIVELY.

Step 1. If blue smoke is present, check to see if intake and exhaust valves are seating properly.

Repair cylinder head (see paragraph 3-6).

Repair intake or exhaust valves (see paragraph 3-12).

Table 2-1. Troubleshooting (Con't).

MALFUNCTION	TEST OR INSPECTION	CORRECTIVE ACTION
Step 2.	If black smoke is present, check to see if fuel injection nozzles are dirty, clogged, or sticking, or if fuel metering pump is defective.	Test, clean, and repair fuel injection nozzles (see paragraph 5-1). Replace fuel metering pump (see paragraph 5-2).
Step 3.	Perform engine assembly compression test (see paragraph 3-1).	Repair as required.
4.	ENGINE OIL PRESSURE TOO LOW.	
Step 1.	Check engine oil pump cover and seal for damage.	Replace as required (see paragraph 3-21).
Step 2.	Check engine oil pump for damage or wear.	Repair or replace engine oil pump (see paragraph 3-21).
5.	ENGINE SPEED IS ERRATIC.	
	Start engine assembly to see if fuel metering pump is working properly (see TM 5-2420-222-10).	Replace fuel metering pump (see paragraph 5-2).
6.	ENGINE NOISY.	
Step 1.	Check engine timing (see paragraph 3-16).	Set engine timing (see paragraph 3-16).
Step 2.	Start engine assembly and operate at idle speed (see TM 5-2420-222-10). Listen for noise at flywheel housing.	If noise is heard, increase engine speed. If noise goes away when engine speed increases, flywheel is loose. Tighten flywheel mounting hardware (see paragraph 3-10).
Step 3.	Start engine assembly and operate at idle speed (see TM 5-2420-222-10). Listen for noise in cylinder block in line with crankshaft.	If noise is heard, increase engine speed. If noise gets louder and engine vibration increases as engine rpm increases, main crankshaft bearings are worn. Replace main crankshaft bearings (see paragraph 3-8).
		If noise is heard, increase engine speed. If noise gets louder as engine rpm increases but engine vibration does not increase, connecting rod sleeve bearing is worn. Replace connecting rod sleeve bearing (see paragraph 3-11).
		If noise is heard, increase engine speed. If noise does not get louder as engine rpm increases, a camshaft bushing is worn. Replace camshaft bushings (see paragraph 3-17). If noise is heard, when increasing and decreasing engine speed, there may be too much lateral movement in crankshaft. A change in engine rpm pushes crankshaft in one direction, then in opposite direction. Adjust crankshaft end play (see paragraph 3-8).

Table 2-1. Troubleshooting (Con't).

MALFUNCTION	TEST OR INSPECTION	CORRECTIVE ACTION
Step 4.	Start engine assembly and operate at idle speed (see TM 5-2420-222-10). Listen for noise at cylinder block just below cylinder head and in line with cylinder bore.	If no noise is heard, increase engine speed. If noise gets louder as engine rpm increases, replace valve springs (see paragraph 3-12).
Step 5.	Remove cylinder head (see paragraph 3-6). Check for foreign material in cylinders.	Remove foreign material. Remove pistons and rings and check for damage (see paragraph 3-11). Check cylinder sleeves for ridge. If ridge is present, replace cylinder sleeves (see paragraph 3-5).
Step 6.	Remove timing gear cover (see paragraph 3-18).	Check for proper end clearance of idler gear and repair as required (see paragraph 3-15).
7. ENGINE OVERHEATS.		
Step 1.	Inspect cylinder head for cracks. If cracks in cylinder head are not seen, start engine assembly and operate at 800 rpm for five minutes (see TM 5-2420-222-10). With engine operating at idle speed, check for engine coolant leakage at exhaust manifold.	If cracks in cylinder head are seen, replace cylinder head (see paragraph 3-6).
Step 2.	Remove cylinder head (see paragraph 3-6). Check for a cracked cylinder sleeve. Crank engine until piston in cylinder being checked is at bottom of cylinder. Visually check cylinder sleeve. Repeat for all four cylinders.	Replace cylinder sleeve if cracked (see paragraph 3-5). If cylinder sleeves are not damaged, replace cylinder head (see paragraph 3-6).
Step 3.	Check valve timing (see paragraph 3-12).	Adjust valve timing (see paragraph 3-12).
Step 4.	Check fuel metering pump drive gear-to-idler gear backlash (see paragraph 3-19).	Adjust fuel metering pump drive gear-to-idler gear backlash (see paragraph 3-19).
Step 5.	Remove engine oil pan (see paragraph 3-20). Check for signs of engine coolant leakage at bottom of cylinder sleeves.	If engine coolant leakage is evident, replace cylinder sleeve(s) packing (see paragraph 3-5). If engine coolant leakage is not evident, check cylinder sleeves and pistons for scoring (see paragraphs 3-5 and 3-11).
8. ENGINE PERFORMS POORLY.		
Step 1.	Perform engine assembly compression test (see paragraph 3-1).	Repair as required.

Table 2-1. Troubleshooting (Con't).

MALFUNCTION	TEST OR INSPECTION	CORRECTIVE ACTION
Step 2.	Check engine timing (see paragraph 3-16).	Set engine timing (see paragraph 3-16). If engine timing is okay, remove cylinder head (see paragraph 3-6) and check cylinder head gasket. If cylinder head gasket is okay, replace valves (see paragraph 3-12).
Step 3.	Remove timing gear cover (see paragraph 3-18). Check fuel metering pump drive gear-to-idler gear backlash (see paragraph 3-19).	Adjust fuel metering pump drive gear-to-idler gear backlash (see paragraph 3-19).
Step 4.	Remove cylinder head (see paragraph 3-6). Check for a scored cylinder sleeve. Crank engine until piston in cylinder being checked is at bottom of cylinder. Visually check cylinder sleeve. Repeat for all four cylinders.	Replace cylinder sleeves (see paragraph 3-5).
Step 5.	Remove timing gear cover (see paragraph 3-18). Check crankshaft end play (see paragraph 3-8).	Adjust crankshaft end play (see paragraph 3-8).
Step 6.	Check end clearance of idler gear (see paragraph 3-15).	Adjust idler gear end play (see paragraph 3-15).
9. ENGINE USES TOO MUCH OIL.		
Step 1.	Perform engine assembly compression test (see paragraph 3-1).	Put a small amount of oil in cylinder and repeat engine compression test (see paragraph 3-1). If compression test readings are now normal, replace piston rings (see paragraph 3-11).
Step 2.	Remove cylinder head (see paragraph 3-6). Check cylinder head gasket for damage.	If cylinder head gasket is damaged, replace cylinder head gasket and install cylinder head (see paragraph 3-6). If cylinder head gasket is okay, check cylinder sleeves for out-of-round condition (see paragraph 3-5) or piston rings for incorrect installation (see paragraph 3-11).
Step 3.	Check rocker arm compartment for signs of too much oil.	If rocker arms compartment has signs of too much oil, problem is clogged oil return holes. Use a thin wire probe and try to clear obstruction from oil return hole.
Step 4.	Remove and disassemble rocker arm assemblies (see paragraph 3-13). Check inside diameter of rocker arms.	Replace rocker arm if defective (see paragraph 3-13).
Step 5.	Measure outside diameter of rocker arm shafts (see paragraph 3-13).	Replace rocker arm shaft if defective (see paragraph 3-13).

Table 2-1. Troubleshooting (Con't).

MALFUNCTION	TEST OR INSPECTION	CORRECTIVE ACTION
	Step 6. Remove valves and check valve stem seals for wear or damage (see paragraph 3-12).	Replace valves if valve stem seals are worn or damaged (see paragraph 3-12).
	Step 7. Check inside diameter of valve guides in three places (see paragraph 3-12).	Replace valve guide if inside diameter is worn or damaged (see paragraph 3-12).
	Step 8. Measure exhaust and intake valves stem diameter (see paragraph 3-12).	Replace valves if measurements are not as specified (see paragraph 3-12).
	Step 9. Check connecting rod sleeve bearings for wear (see paragraph 3-11).	Replace connecting rod sleeve bearings if worn (see paragraph 3-11).

CLUTCH ASSEMBLY

10. CLUTCH SLIPS.

- Step 1. Check for worn or broken shifter levers.
Replace shifter levers (see paragraph 8-14).
- Step 2. Remove transmission top cover (see paragraph 8-12 or 8-13). Check to see if gears rotate with clutch pedal depressed.
Replace worn or damaged friction plugs (see paragraph 8-4).
- Step 3. Remove transmission top cover (see paragraph 8-12 or 8-13). Check to see if transmission oil pump is working properly.
Repair or replace transmission oil pump (see paragraph 8-19).

11. CLUTCH PEDAL VIBRATES.

- Step 1. Check for bent or damaged engine crankshaft.
Replace engine crankshaft (see paragraph 3-8).
- Step 2. Check for loose or damaged engine flywheel and ring gear.
Repair or replace engine flywheel and ring gear (see paragraph 3-9).

12. CLUTCH NOISY.

- Step 1. Check for loose clutch disk at hub rivets (see paragraph 4-1 or 4-2).
Replace clutch disk (see paragraph 4-1 or 4-2).

Table 2-1. Troubleshooting (Con't).

MALFUNCTION	TEST OR INSPECTION	CORRECTIVE ACTION
	Step 2.	Check for worn or warped clutch disk (see paragraph 4-1 or 4-2). Replace clutch disk (see paragraph 4-1 or 4-2).
	Step 3.	Check for loose or damaged engine flywheel and ring gear. Repair or replace engine flywheel and ring gear (see paragraph 3-9).
	Step 4.	Check for worn or damaged clutch support bearing carrier. Replace clutch support bearing carrier (see paragraph 4-4).
	Step 5.	Check for loose clutch release levers. Replace clutch release lever (see paragraph 4-1 or 4-2).
13. CLUTCH DRAGS.		
	Step 1.	Check for worn or broken clutch disk (see paragraph 4-1 or 4-2). Replace clutch disk (see paragraph 4-1 or 4-2).
	Step 2.	Check for loose or damaged clutch release bearings or clutch support bearing carrier. Replace as required (see paragraph 4-1 or 4-4).
	Step 3.	Check for worn clutch support bearing carrier. Replace clutch support bearing carrier (see paragraph 4-4).
	Step 4.	Check for sticking or damaged pressure plate. Replace pressure plate (see paragraph 4-1 or 4-2).

TRANSMISSION

14. TRANSMISSION SHIFTS TOO SLOWLY.

Remove reverser clutch control valve assembly (see paragraph 8-20). Check for broken or damaged pressure regulating control valve springs or washers (shims).

Replace pressure regulating control valve springs or washers (shims) (see paragraph 8-20).

15. TRANSMISSION SHIFTS TOO FAST.

Remove reverser clutch control valve assembly (see paragraph 8-20). Check quantity and size of washers (shims).

Remove washers (shims) as required (see paragraph 8-20).

Table 2-1. Troubleshooting (Con't).

MALFUNCTION	TEST OR INSPECTION	CORRECTIVE ACTION
-------------	--------------------	-------------------

16. EXCESSIVE GEAR CLASH WHEN SHIFTING.

Step 1. Check for worn or broken shifter levers.

Replace shifter levers (see paragraph 8-14).

Step 2. Remove transmission top cover (see paragraph 8-12 or 8-13). Check to see if gears rotate with clutch pedal depressed.

Replace worn or damaged friction plugs (see paragraph 8-4).

Step 3. Remove transmission top cover (see paragraph 8-12 or 8-13). Check to see if transmission oil pump is working properly.

Repair or replace transmission oil pump (see paragraph 8-19).

17. TRANSMISSION NOISY.

Step 1. Remove transmission top cover (see paragraph 8-12 or 8-13). Check to see if transmission oil pump is working properly.

Repair or replace transmission oil pump (see paragraph 8-19).

Step 2. Inspect transmission for worn or damaged parts.

Repair or replace transmission (see paragraph 8-2).

Step 3. Check differential assembly for worn or damaged bearings or gears.

Repair differential assembly (see paragraph 8-7).

Repair differential drive shaft assembly (see paragraph 8-6).

Step 4. Check to see if ring gear is out of adjustment or damaged.

Adjust or replace ring gear (see paragraph 8-6).

18. NO DIFFERENTIAL ACTION.

Step 1. Check for worn or damaged bevel pinion gear (see paragraph 8-7).

Replace bevel pinion gear (see paragraph 8-7).

Step 2. Check to see if ring gear is out of adjustment or damaged (see paragraph 8-6).

Adjust or replace ring gear (see paragraph 8-6).

19. DIFFERENTIAL WILL NOT LOCK.

Step 1. Check to see if lock pedal turns on shaft.

Tighten lock pedal (see paragraph 8-8).

Table 2-1. Troubleshooting (Con't).

MALFUNCTION	TEST OR INSPECTION	CORRECTIVE ACTION
-------------	--------------------	-------------------

Step 2. Check for worn or damaged lock collar splines.

Replace lock collar (see paragraph 8-9).

Step 3. Check for worn or damaged bevel pinion gear (see paragraph 8-7).

Replace bevel pinion gear (see paragraph 8-7).

20. TRANSMISSION JUMPS WHEN ENGAGED.

Perform transmission oil pressure test (see paragraph 8-1).

Repair or replace reverser clutch control valve assembly (see paragraph 8-20).

21. CLUTCH OR BRAKE SLIPS UNDER LOAD.

With engine running, engage clutch pedal with reverser lever in forward position until unit moves (see TM 5-2420-222-10). Depress clutch pedal and lock brakes. Place transmission in eighth gear. Run engine at fast idle and engage clutch. Engine must stall within five seconds after clutch pedal is released. Repeat stall with reverser lever in reverse position and transmission in fourth gear.

If engine does not stall within five seconds, repair or replace reverser clutch control valve assembly (see paragraph 8-20). Repair reverser clutch drum and disks (see paragraph 8-18).

REAR AXLE HOUSING

22. REAR AXLE HOUSING NOISY.

Step 1. Check for broken axle shaft, bearings, or planetary pinion carrier.

Repair or replace as required (see paragraph 9-3).

Step 2. Check for broken final drive shaft or pinion gear (see paragraph 8-6).

Replace final drive shaft or pinion gear (see paragraph 8-6).

BRAKES

23. EXCESSIVE PEDAL LEAK-DOWN.

Step 1. Check hydraulic brake cylinder for leaking pistons (see paragraph 10-4).

Replace preformed packing on piston (see paragraph 10-4).

Table 2-1. Troubleshooting (Con't).

MALFUNCTION	TEST OR INSPECTION	CORRECTIVE ACTION
	Step 2. Remove rear axle housing (see paragraph 9-3). Check for leakage past pressure plate.	Repair pressure plate (see paragraph 10-3).
	Step 3. Check hydraulic brake cylinder for defective check valve or equalizing valve.	Repair or replace hydraulic brake cylinder (see paragraph 10-4).
24. BRAKES DO NOT HOLD OR STOP LOADER BACKHOE.	Check for worn or damaged brake disks and pressure plate.	Repair or replace as required (see paragraph 10-3).
<i>STEERING</i>		
25. STEERING WHEEL DOES NOT CENTER.	Check steering valve for broken centering springs.	Replace centering springs (see paragraph 11-3).
26. NO RESPONSE WHEN STEERING WHEEL IS TURNED SLOWLY.	Check steering valve for worn or damaged control sleeve and spool.	Replace steering valve (see paragraph 11-3).
27. WRONG RESPONSE TO STEERING.	Check steering valve gear for damage.	Replace steering valve gear (see paragraph 11-3).
28. CONTINUOUS STEERING WHEEL ROTATION AND NO RESPONSE.	Step 1. Check steering cylinders for leakage.	Repair steering cylinders (see paragraph 11-2).
	Step 2. Check steering column for broken steering shaft.	Replace steering shaft (see paragraph 11-1).
	Step 3. Check steering valve for broken centering springs.	Replace centering springs (see paragraph 11-3).

Table 2-1. Troubleshooting (Con't).

MALFUNCTION	TEST OR INSPECTION	CORRECTIVE ACTION
Step 4.	Check steering valve for worn, damaged, or locked control sleeve and spool.	Replace steering valve (see paragraph 11-3).

HYDRAULIC SYSTEM

NOTE

Use the following malfunction to troubleshoot inoperative loader boom, loader bucket, backhoe boom, dipperstick, and crowd or Jaw cylinders.

29. CYLINDER FAILS TO WORK.

Perform hydraulic system test (see paragraph 14-1). Check for worn, damaged, or inoperative hydraulic pump.

Repair or replace hydraulic pump assembly (see paragraph 14-3).

30. HYDRAULIC FLUID FOAMS.

Step 1. Perform hydraulic system test (see paragraph 14-1). Check for worn or damaged hydraulic pump or loose fittings.

Repair or replace hydraulic pump assembly (see paragraph 14-3).

Tighten loose fittings.

Step 2. Check hydraulic pump for worn or damaged pump shaft seal.

Replace pump shaft seal (see paragraph 14-3).

**CHAPTER 3
ENGINE ASSEMBLY MAINTENANCE**

Section I. ENGINE ASSEMBLY MAINTENANCE

Paragraph Number	Paragraph Title	Page Number
3-1	Engine Assembly Compression Test	3-2
3-2	Engine Assembly Vacuum Test	3-5
3-3	Engine Assembly Replacement	3-7
3-4	Engine Block Maintenance.....	3-22
3-5	Cylinder Sleeve Maintenance.....	3-32
3-6	Cylinder Head Maintenance	3-36
3-7	Cylinder Block Plate Replacement.....	3-41
3-8	Crankshaft Maintenance	3-44
3-9	Engine Flywheel and Ring Gear Maintenance.....	3-59
3-10	Flywheel Housing Maintenance.....	3-62
3-11	Piston, Connecting Rod, and Connecting Rod Bearing Maintenance.....	3-67
3-12	Valve Maintenance.....	3-77
3-13	Rocker Arm, Shaft, and Pushrod Maintenance.....	3-81
3-14	Tappet Replacement.....	3-86
3-15	Idler Gears Replacement	3-88
3-16	Engine Timing	3-96
3-17	Camshaft Maintenance	3-98
3-18	Timing Gear Cover Maintenance	3-103
3-19	Control Cams, Gears, and Bushings Replacement	3-110

3-1. ENGINE ASSEMBLY COMPRESSION TEST.

This Task Covers: Test

Initial Setup:

Equipment Conditions:

- Fuel injection nozzles removed (see TM 5-2420-222-20).

Tools/Test Equipment:

- General mechanic's tool kit
- Field automotive shop set

References:

- TM 5-2420-222-20

Materials/Parts:

- Engine oil (Item 25, Appendix B)
- Marker tags (Item 32, Appendix B)
- Electrical tape (Item 36, Appendix B)
- One self-locking nut

Personnel Required: Two**General Safety Instructions:**

- Wrap wiring harness terminal with electrical tape when disconnected

TEST

1. Remove self-locking nut (3) and wiring harness terminal (4) from fuel injection pump shutoff solenoid terminal (5). Discard self-locking nut.

WARNING

To prevent electrical shock, exposed wiring harness terminal must be wrapped with electrical tape before connecting battery ground cable.

2. Wrap wiring harness terminal (4) with electrical tape.
3. Connect battery ground cable to battery (see TM 5-2420-222-20).

NOTE

Compression of all four cylinders is tested the same way. One cylinder is shown. Repeat steps 4 through 7 for remaining cylinders as required.

4. Install cylinder compression tester in fuel injector hole (1) on cylinder head (2).

WARNING

Stay clear of rotating fan blades when cranking engine. Failure to follow this warning may result in serious injury to personnel.

CAUTION

Do not operate starter for more than 20 seconds at a time. Allow two minutes for cooling before using starter again, or it may overheat.

5. Crank engine assembly with starter for about five seconds while an assistant records cylinder compression tester reading.
6. Remove cylinder compression tester and add 1 oz (29.57 ml) of clean engine oil in combustion chamber.

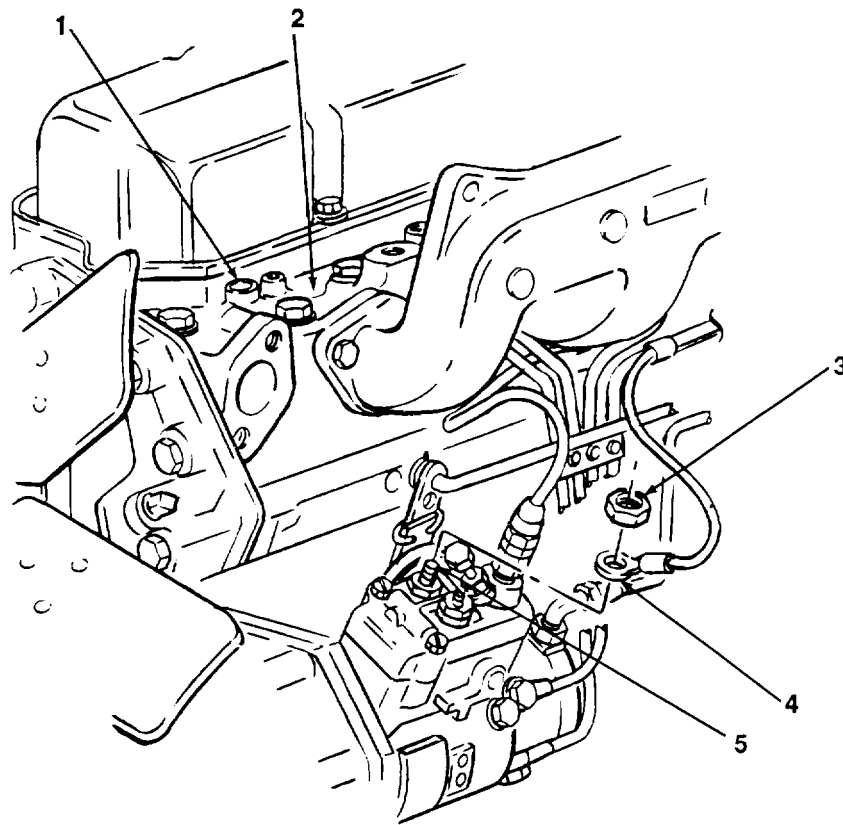
3-1. ENGINE ASSEMBLY COMPRESSION TEST (Con't).

7. Install cylinder compression tester in fuel injector hole (1) and repeat step 5.
8. Minimum allowable cylinder compression pressure is 350 psi (2413 kPa). Pressure below 350 psi (2413 kPa) is not acceptable. Difference in pressure between cylinders must not exceed 50 psi (345 kPa).
 - (a) If first test on dry cylinder shows pressure less than specifications, and second test with oil in cylinder shows the same low pressure, disassemble engine and check valves on this cylinder.
 - (b) If first test on dry cylinder shows pressure less than specifications, and second test with oil in cylinder shows normal pressure, disassemble engine and check piston and piston rings for defects.
 - (c) If difference in pressure between cylinders is more than 50 psi (345 kPa), disassemble engine and check for defects as described above.
 - (d) If first test on dry cylinder shows pressure less than specifications in two cylinders next to each other, and second test with oil in cylinder shows the same low pressure in the same two cylinders, disassemble engine and check for a defective head gasket.

TA701218

3-1. ENGINE ASSEMBLY COMPRESSION TEST (Con't).

WARNING

Although battery ground cable must be connected to test electrical circuit voltage, disconnect battery ground cable before doing resistance tests or replacing parts. This will prevent injury from electrical shock and possible damage to equipment.

9. Disconnect battery ground cable from battery (see TM 5-2420-222-20).
10. Remove electrical tape from wiring harness terminal (4). Position wiring harness terminal in place on fuel injection pump shutoff solenoid terminal (5) and install new self-locking nut (3).

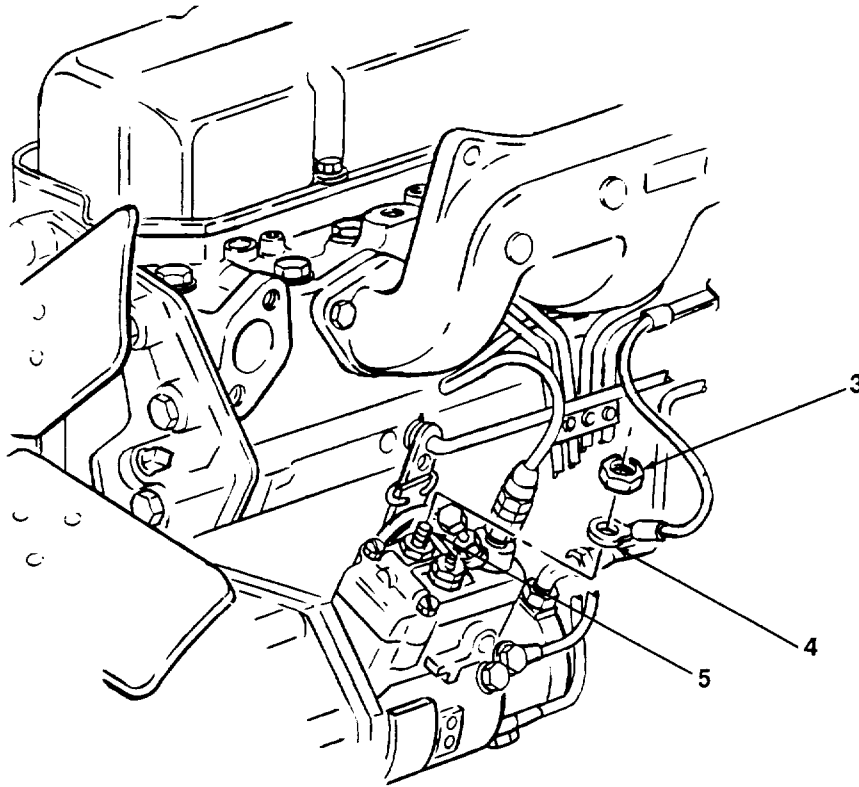
**FOLLOW-ON TASKS:**

- Install fuel injection nozzles (see TM 5-2420-222-20).

TA701219

3-2. ENGINE ASSEMBLY VACUUM TEST.

This Task Covers: Test

Initial Setup:

Tools/Test Equipment:

- General mechanic's tool kit
- U-tube manometer

References:

- TM5-2420-222-10
- TM5-2420-222-20

Personnel Required: Two

TEST

1. Remove air cleaner restriction indicator (1) from air cleaner (2) (see TM 5-2420-222-20).
2. Using a suitable tee, connect U-tube manometer and air cleaner restriction indicator (1) to air cleaner (2).

WARNING

Be careful of moving parts when working near engine while it is running. Moving parts could catch on tools, clothing, or extremities causing serious injury to personnel.

3. Start engine assembly and run at low idle (see TM5-2420-222-10).
4. Record U-tube manometer and air cleaner restriction indicator (1) readings. Normal vacuum is 3.5 in. (8.89 cm) of water. A reading of 11 in. (27.94 cm) or more of water indicates a dirty air cleaner element or other restriction.

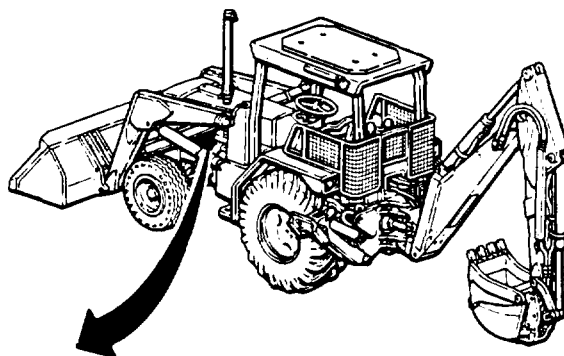
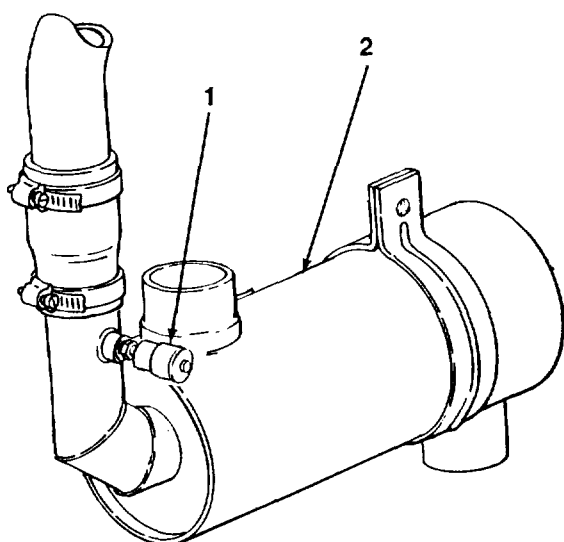

3-2. ENGINE ASSEMBLY VACUUM TEST (Con't).

5. Increase engine speed to 2500 rpm. Apply full load by setting parking brake and placing transmission gearshift in forward position, lock brakes, and release clutch pedal to engage clutch (see TM5-2420-222-10). lever in low range. Place transmission gearshift lever in first gear, speed gear assembly (reverser) control lever
6. Record U-tube manometer and air cleaner restriction indicator (1) readings. Maximum allowable vacuum is 25 in. (63.50 cm) of water. If air cleaner restriction indicator and U-tube manometer did not agree at first reading in step 4 or second reading in this step, replace air cleaner restriction indicator (see TM5-2420-222-20).
7. Shut down engine assembly (see TM5-2420-222-10).
8. Disconnect U-tube manometer, air cleaner restriction indicator (1), and tee from air cleaner (2).
9. Install air cleaner restriction indicator (1) on air cleaner (2) (see TM5-2420-222-20).

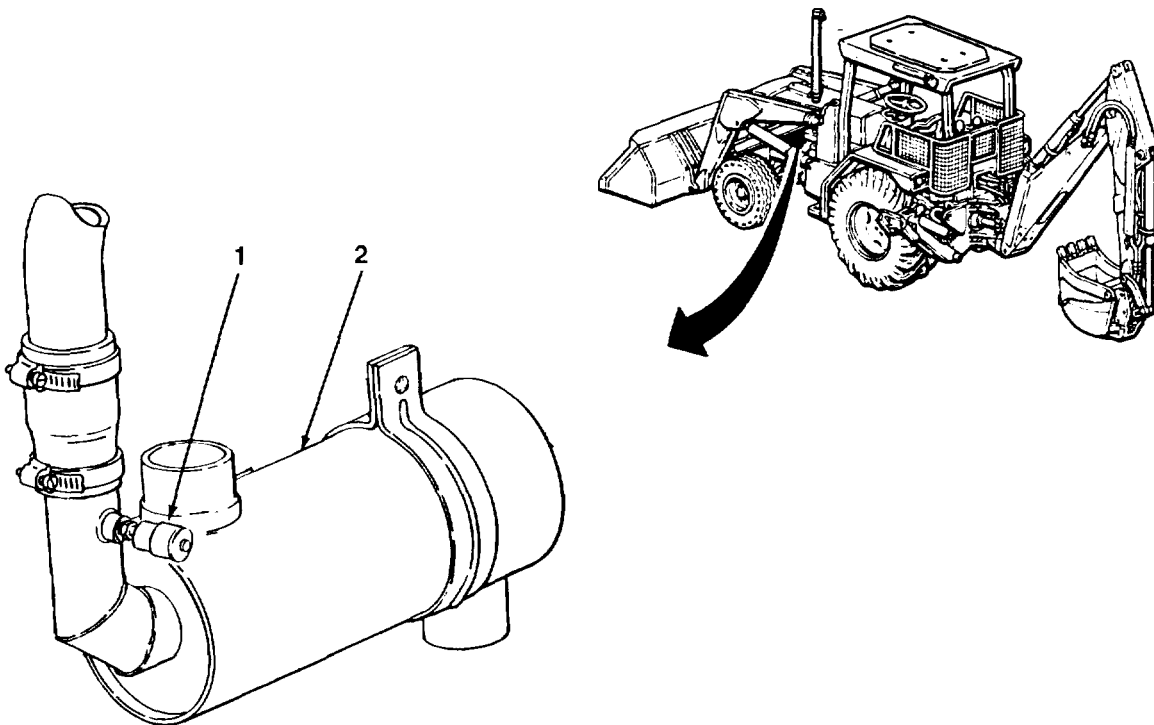

TA701221

3-3. ENGINE ASSEMBLY REPLACEMENT.*This Task Covers:*

- a. Removal b. Installation

*Initial Setup:***Equipment Conditions:**

- Frame assembly front support removed (see paragraph 12-1).
- Muffler removed (see TM 5-2420-222-20).
- Steering valve oil lines removed (see TM5-2420 222-20).
- Electric horn and bracket removed (see TM5-2420-222-20).
- Accumulator tee-to-steering valve oil line remove (see TM 5-2420-222-20).
- Right inner platform ramp removed (see TM 5-2420-222-20).
- Alternator disconnected (see TM 5-2420-222-20).
- Starter disconnected (see TM 5-2420-222-20).

Tools/Test Equipment:

- General mechanic's tool kit
- Field automotive shop set
- Lifting adapter
- Steam cleaner

Materials/Parts:

- Marker tags (Item 32, Appendix B)
- Adhesive tape (Item 33, Appendix B)
- One cotter pin
- One gasket
- One self-locking nut
- Seventeen lockwashers
- Tie-down bands (as required)

Personnel Required: Two**General Safety Instructions:**

- DO NOT use a dry brush or compressed air to clean clutch assembly or clutch components.

a. REMOVAL

1. Remove tachometer drive cable (1) and gasket (2) from reverser housing (3). Discard gasket.

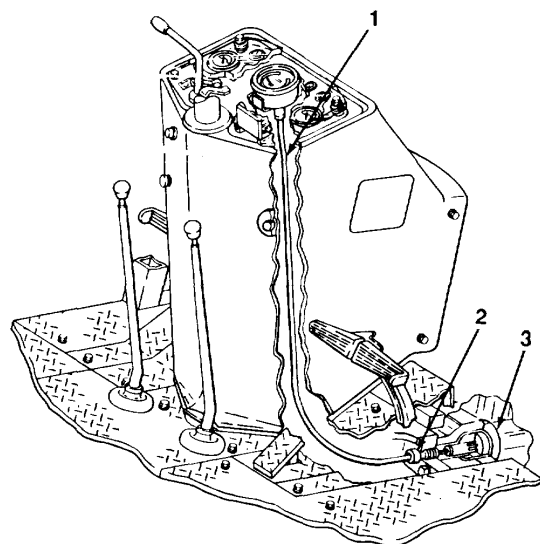

TA701222

3-3. ENGINE ASSEMBLY REPLACEMENT (Con't).**NOTE**

Steps 2 and 3 apply only to loader backhoes with serial numbers 235786-235999.

2. Remove solenoid lead terminal (6) from engine starting aid fluid injection solenoid terminals (5 and 7).
3. Remove two screws (14), washers (13), lockwashers (11), washers (10), nuts (12), engine starting aid fluid injection solenoid (8), bracket (9), and ground terminal (4) from solenoid bracket (9) and terminal (16). Discard lockwashers.

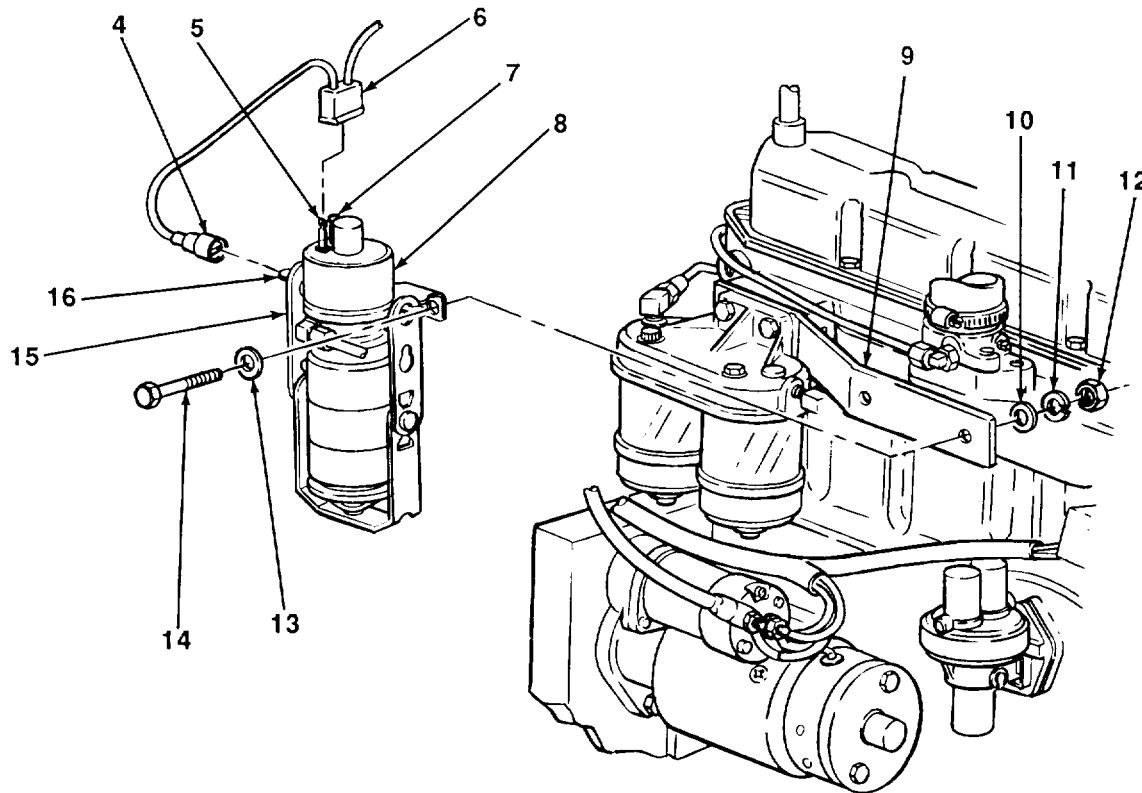

4. Remove cotter pin (21) and washer (20) from speed control rod (18). Remove speed control rod from shaft (19). Discard cotter pin.
5. Using adhesive tape, secure speed control rod (18) to engine block (22).
6. Remove self-locking nut (25) and wiring harness terminal (26) from fuel injection pump shutoff solenoid terminal (17). Discard self-locking nut.
7. Remove tie-down bands (23) from main wiring harness fuel shutoff lead (24). Discard bands.
8. Remove main wiring harness fuel shutoff lead (24) from engine block (22).

TA701223

3-3. ENGINE ASSEMBLY REPLACEMENT (Con't).

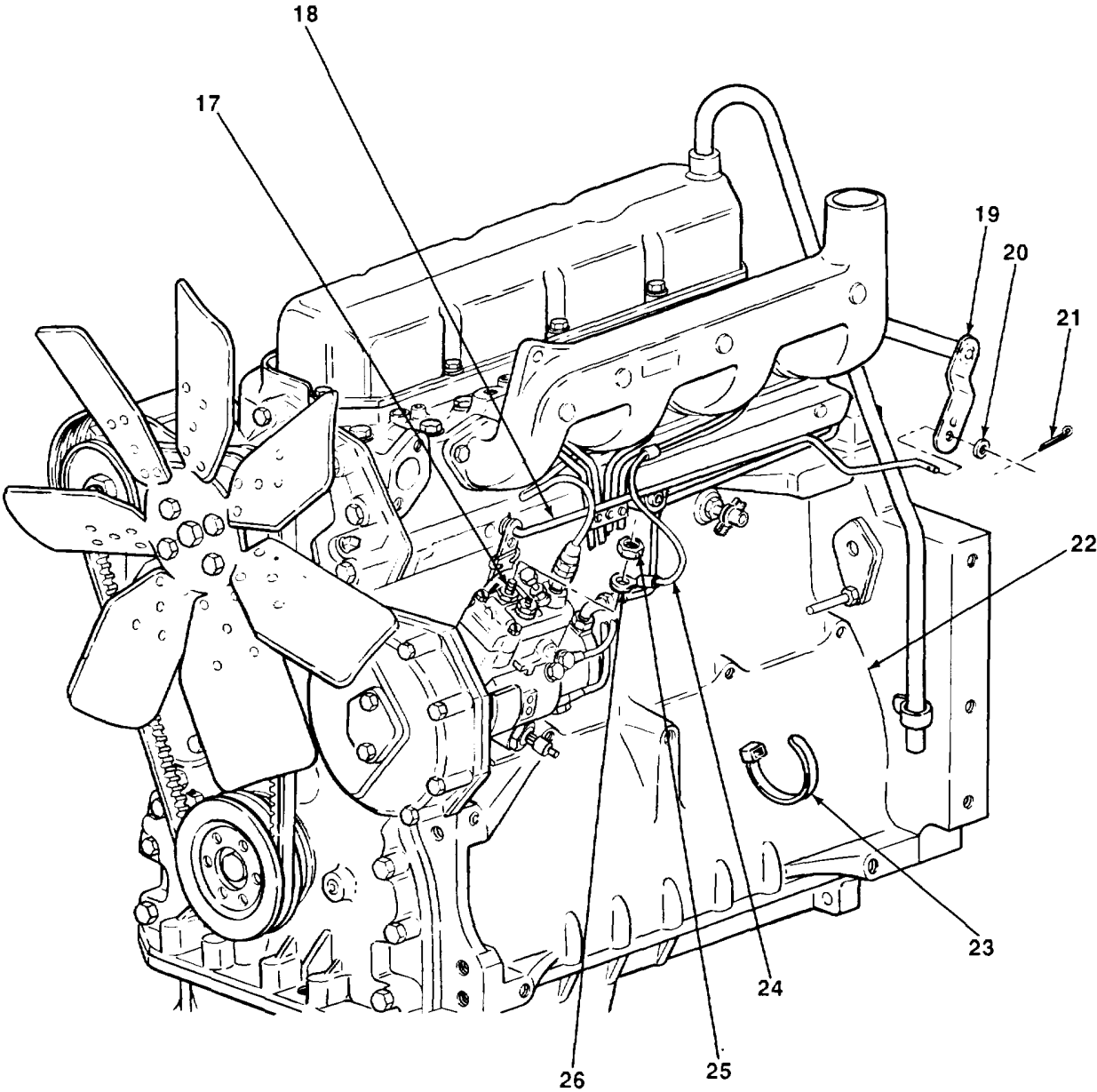

TA701224

3-3. ENGINE ASSEMBLY REPLACEMENT (Con't).

9. Remove two screws (27) and lockwashers (28) from flywheel housing (30) and cowl support (29). Discard lockwashers.

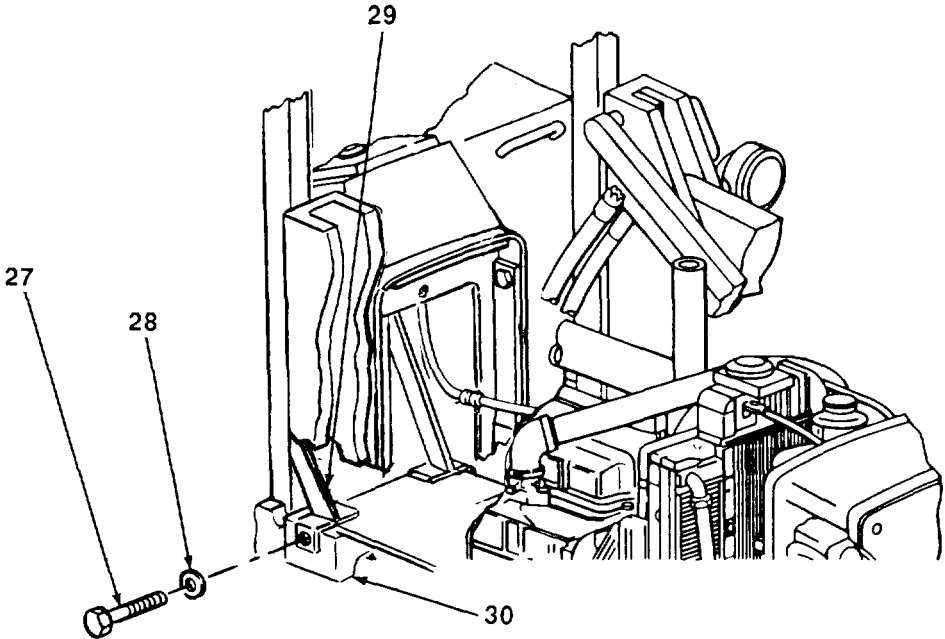

10. Remove jamnut (31), water temperature sensor (34), and capillary tube (32) from adapter (33).

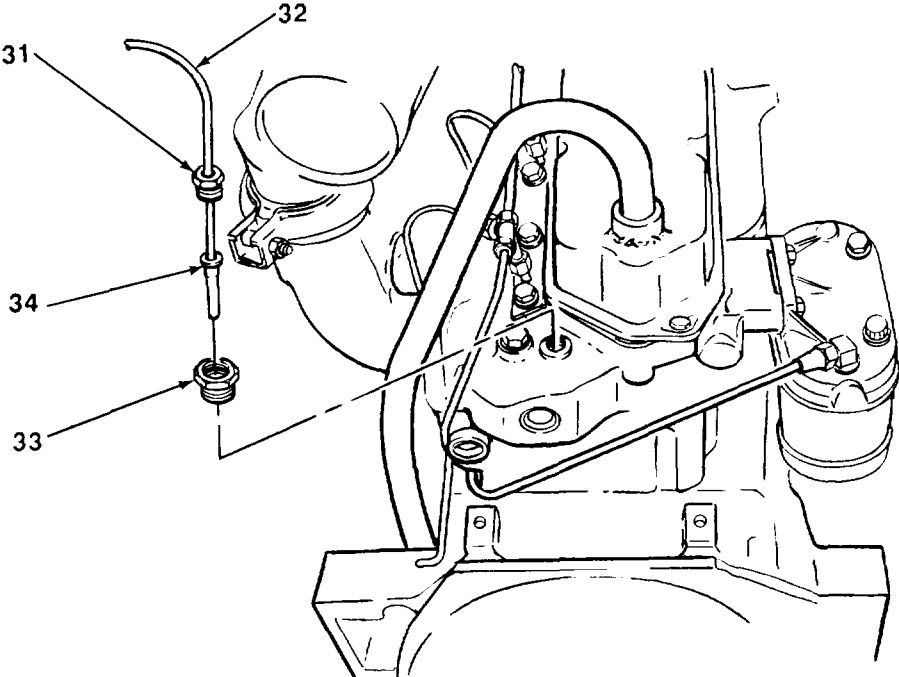

3-3. ENGINE ASSEMBLY REPLACEMENT (Con't).

11. Remove pump pressure line-to-accumulator hose (41) from tee (40) and accumulator (45). Cap tee and plug accumulator.
12. Install three $\frac{1}{2}$ in. -13 UNC threaded eyebolts (36) in lift points of cylinder head (38).

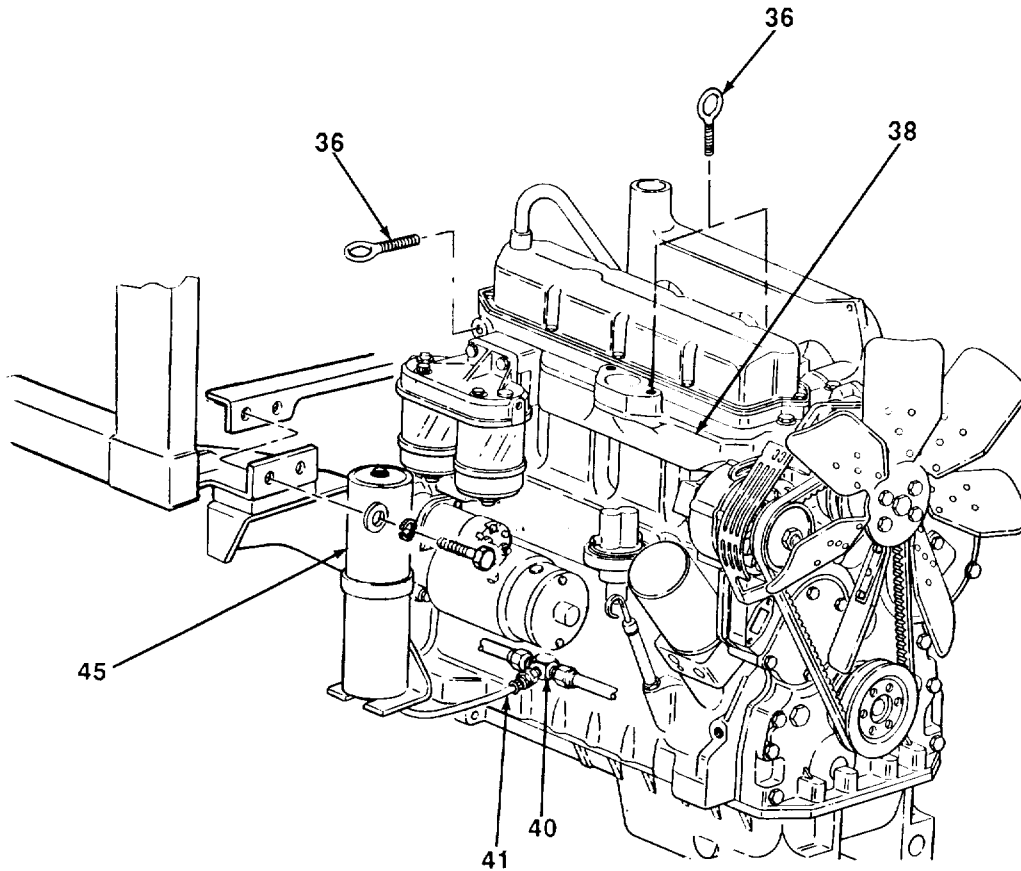

TA701226

3-3. ENGINE ASSEMBLY REPLACEMENT (Con't).**WARNING**

Use extreme caution when handling heavy parts. Lifting device is required when parts weigh over 50 lb (23 kg) for a single person lift, over 100 lb (45 kg) for a two person lift, and over 150 lb (68 kg) for a three or more person lift. Keep clear of heavy parts supported only by lifting device. Failure to follow this warning may cause serious injury or death to personnel.

13. Position lifting device over engine assembly (39). Connect engine and transmission sling (37) to eyebolts (36) and to lifting device and support engine assembly.
14. Remove four screws (42), lockwashers (43), washers (44), and front crossmember (35) from canopy. Discard lockwashers.

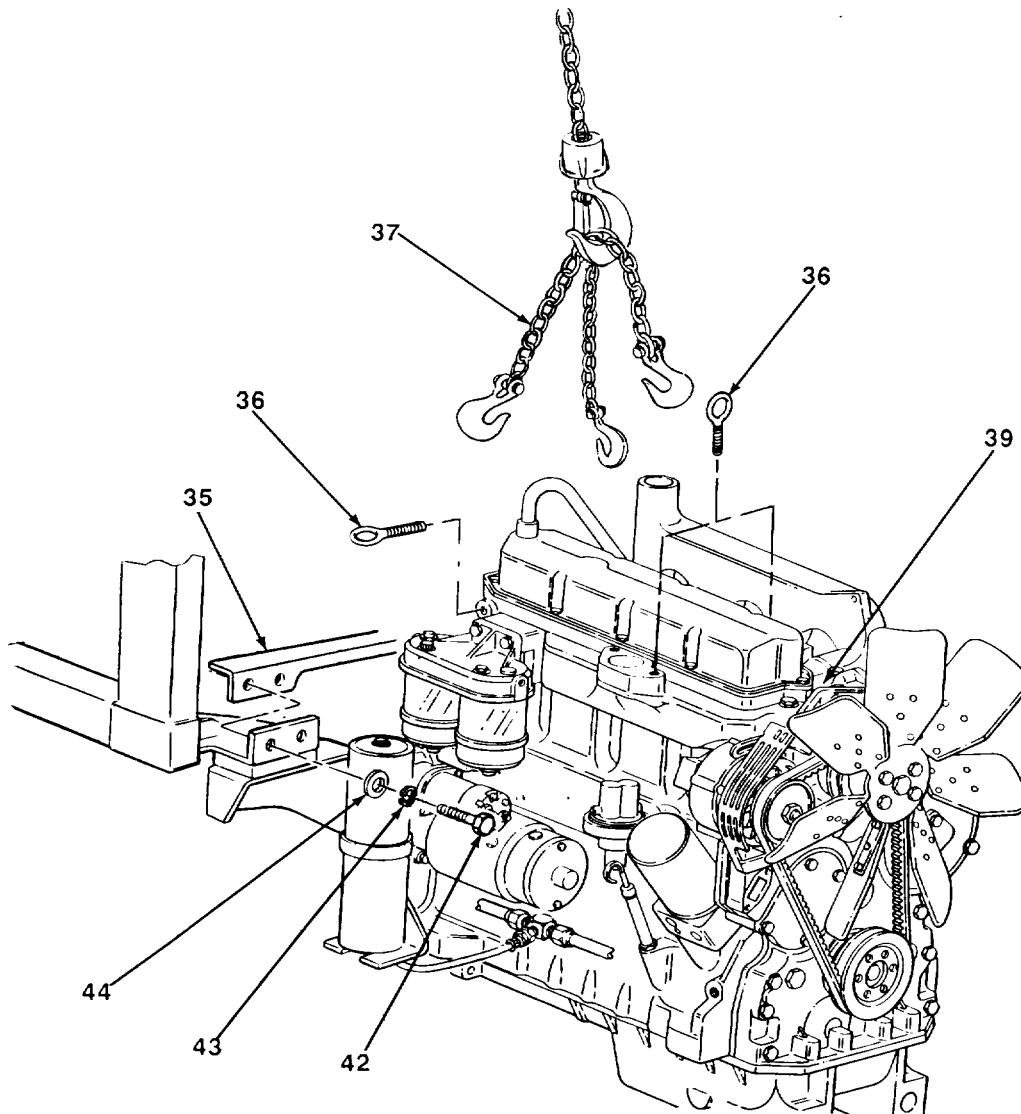

3-3. ENGINE ASSEMBLY REPLACEMENT (Con't).

15. Remove four screws (50) and washers (51) from flywheel housing (30) and reverser housing (3).
16. Remove two screws (56) and lockwashers (55) from engine oil pan, flywheel housing (30), and reverser housing (3). Discard lockwashers.
17. Remove two screws (47), lockwashers (53), nuts (52), upper engine mounts (49), lower engine mounts (54), and washers (48) from left and right brackets (46). Discard lockwashers.

WARNING

Parts of clutch assembly will be coated with asbestos dust. Breathing this dust may be hazardous to your health. Use an approved filter mask for use against asbestos dust. Never use compressed air or a dry brush to clean these parts. Dust must be removed with an industrial-type vacuum cleaner equipped with a high efficiency filter system.

18. With two assistants, raise lifting device until it supports engine assembly (39). Move lifting device forward until engine assembly clears reverser housing (3).
19. Raise lifting device and remove engine assembly (39) from loader backhoe.
20. Lower lifting device and install engine assembly (39) on engine stand or wood blocks.
21. Remove lifting device, engine and transmission sling (37), and eyebolts (36) from engine assembly (39).

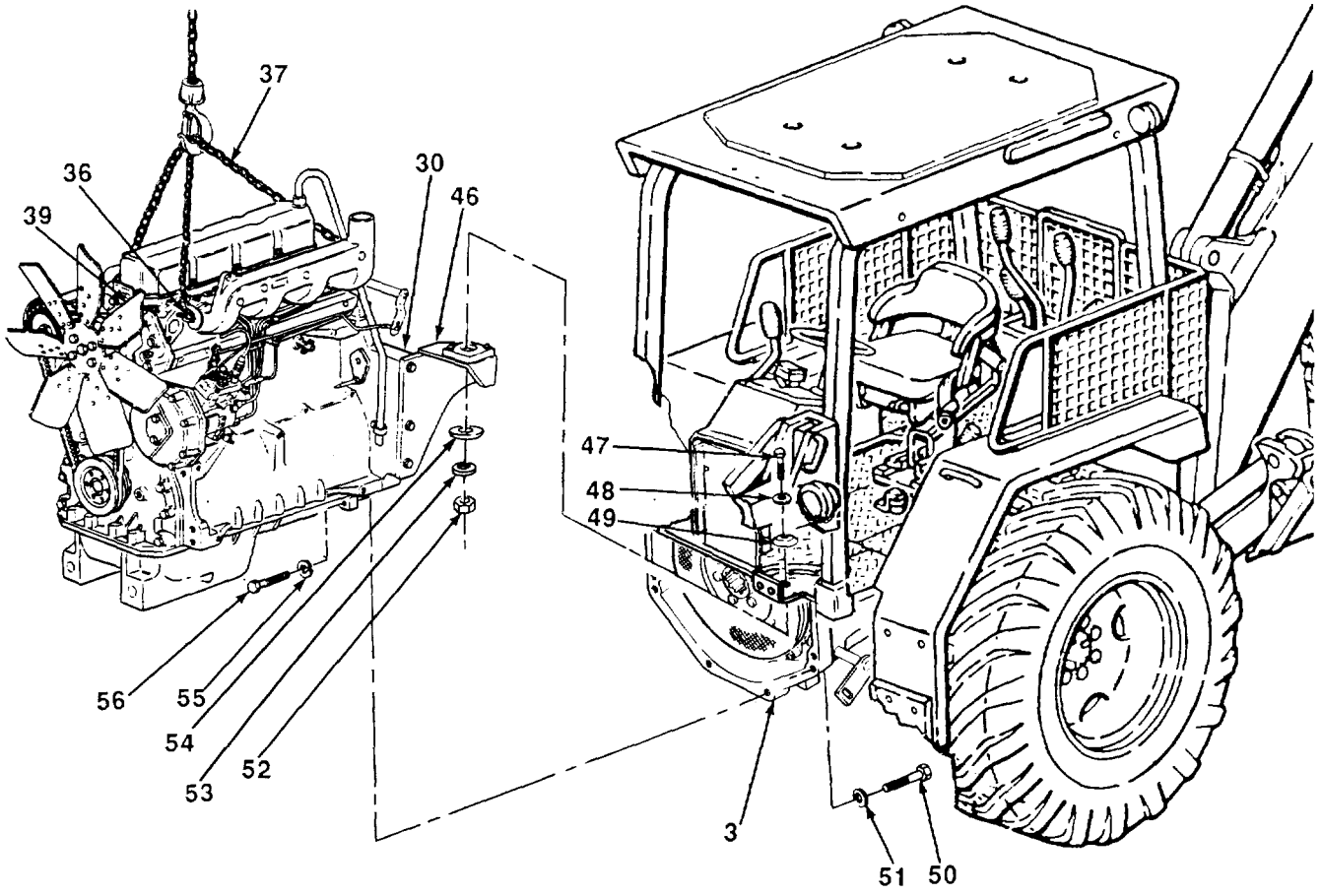

TA701228

3-3. ENGINE ASSEMBLY REPLACEMENT (Con't).**NOTE**

**Loader backhoes with serial numbers 319995-342573 have washers.
Loader backhoes with serial numbers 235786-235999 do not have washers.**

22. Remove three screws (63), lockwashers (62), washers (61), accumulator bracket (60), and right bracket (46) from engine assembly (39). Discard lockwashers.
23. Remove three screws (59), lockwashers (58), washers (57), and left bracket (46) from engine assembly (39). Discard lockwashers.

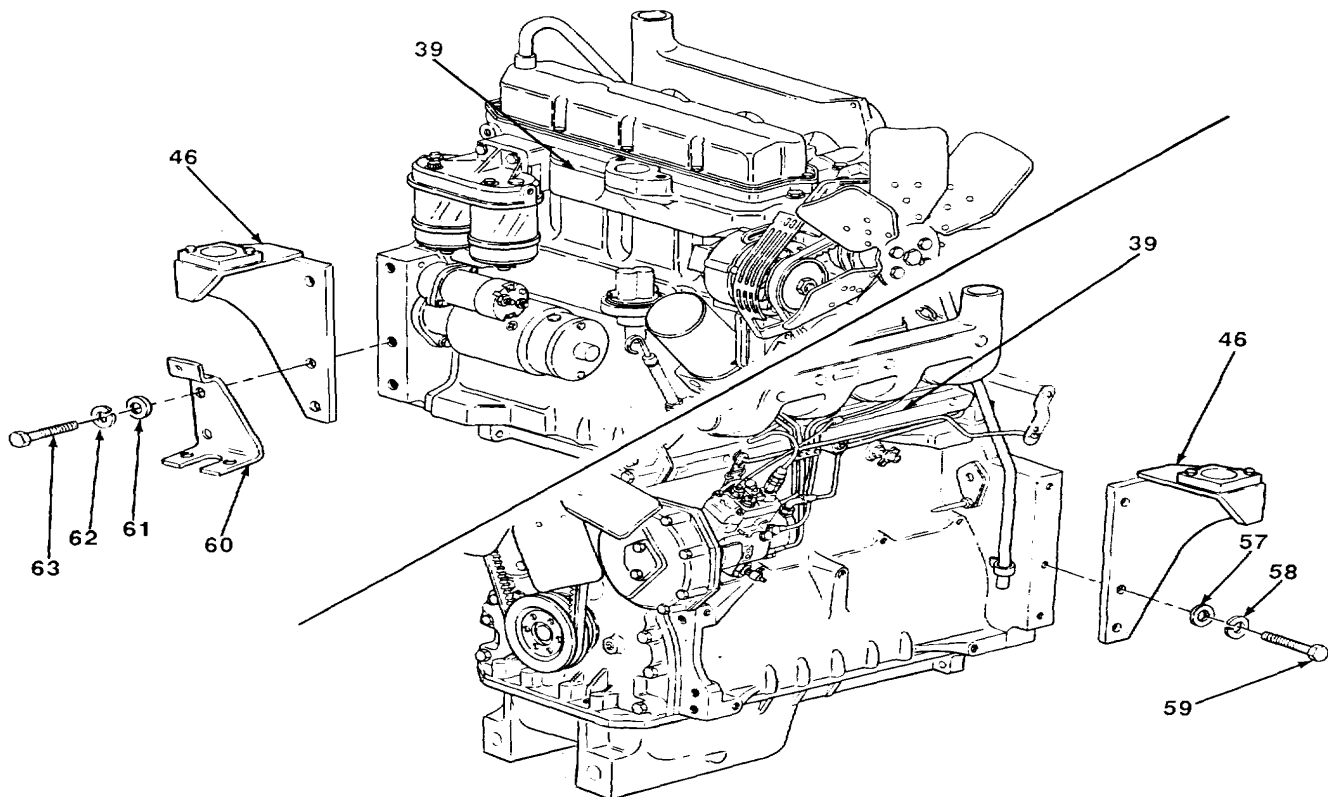
**b. INSTALLATION****NOTE**

**Loader backhoes with serial numbers 319995-342573 have washers.
Loader backhoes with serial numbers 235786-235999 do not have washers.**

1. Install left bracket (46) on engine assembly (39) with three screws (59), new lockwashers (58), and washers (57).
2. Install right bracket (46) and accumulator bracket (60) on engine assembly (39) with three screws (63), new lockwashers (62), and washers (61). Torque screws (59 and 63) to 170 lb.-ft. (230 N•m).

TA701229

3-3. ENGINE ASSEMBLY REPLACEMENT (Con't).

3. Install three $\frac{1}{2}$ in. -13 UNC threaded eyebolts (36) in lift points of cylinder head (38).
4. Position lifting device over engine assembly (39). Connect engine and transmission sling (37) to eyebolts (36) and to lifting device.

WARNING

- Use extreme caution when handling heavy parts. Lifting device is required when parts weigh over 50 lb (23 kg) for a single person lift, over 100 lb (45 kg) for a two person lift, and over 150 lb (68 kg) for a three or more person lift. Keep clear of heavy parts supported only by lifting device. Failure to follow this warning may cause serious injury or death to personnel.
 - Parts of clutch assembly will be coated with asbestos dust. Breathing this dust may be hazardous to your health. Use an approved filter mask for use against asbestos dust. Never use compressed air or a dry brush to clean these parts. Dust must be removed with an industrial-type vacuum cleaner equipped with a high efficiency filter system.
5. Using lifting device, raise engine assembly (39) off engine stand or wood blocks and position over loader backhoe.
 6. Install upper engine mount (49) and lower engine mount (54) in left and right brackets (46).

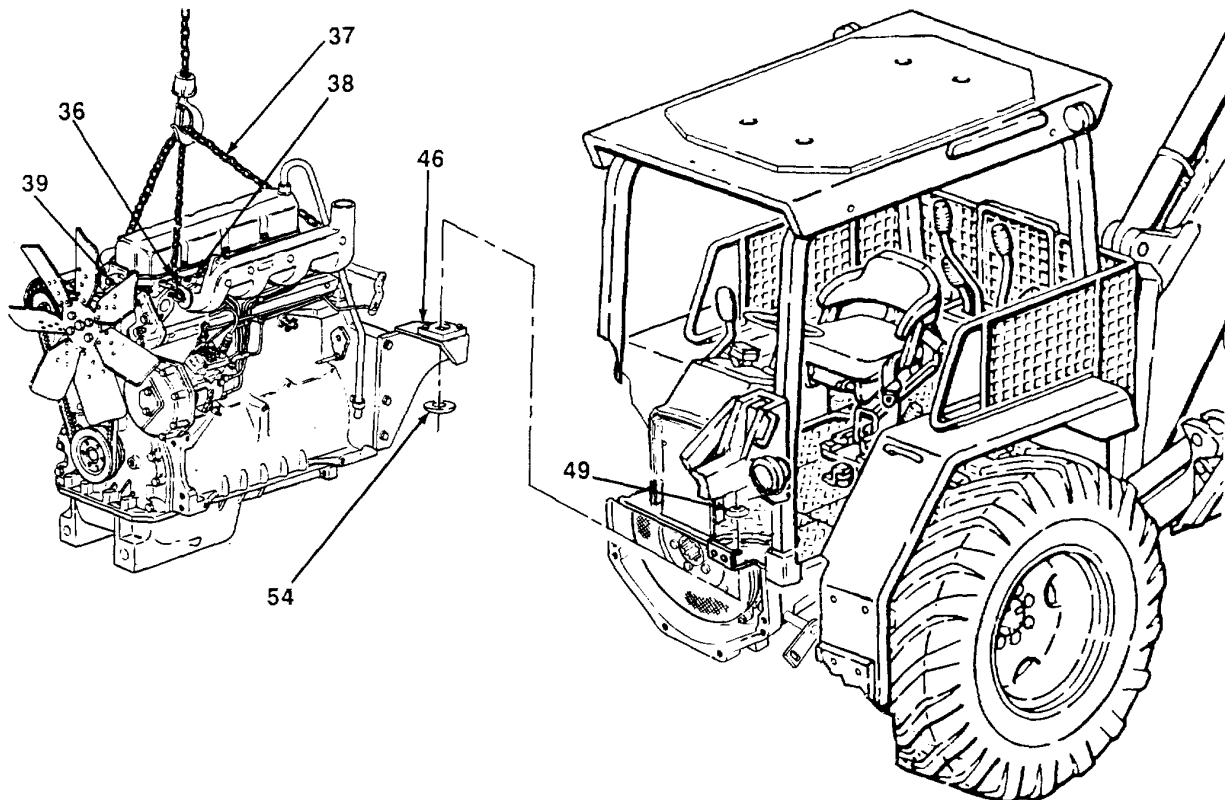

3-3. ENGINE ASSEMBLY REPLACEMENT (Con't).

7. With two assistants, lower lifting device until engine assembly (39) is alined with reverser housing (3). Move lifting device rearward until engine assembly engages reverser housing.
8. Install two screws (47), new lockwashers (53), washers (48), and nuts (52) in left and right brackets (46).
9. Install two screws (56) and new lockwashers (55) in engine oil pan, flywheel housing (30) and reverser housing (3). Torque screws to 250 lb.-ft. (339 Nom).
10. Install four screws (50) and washers (51) in flywheel housing (30) and reverser housing (3). Torque screws to 250 lb.-ft. (339 N•m).
11. Position wood block under engine assembly (39). Remove lifting device, engine and transmission sling (37), and three eyebolts (36) from engine assembly.

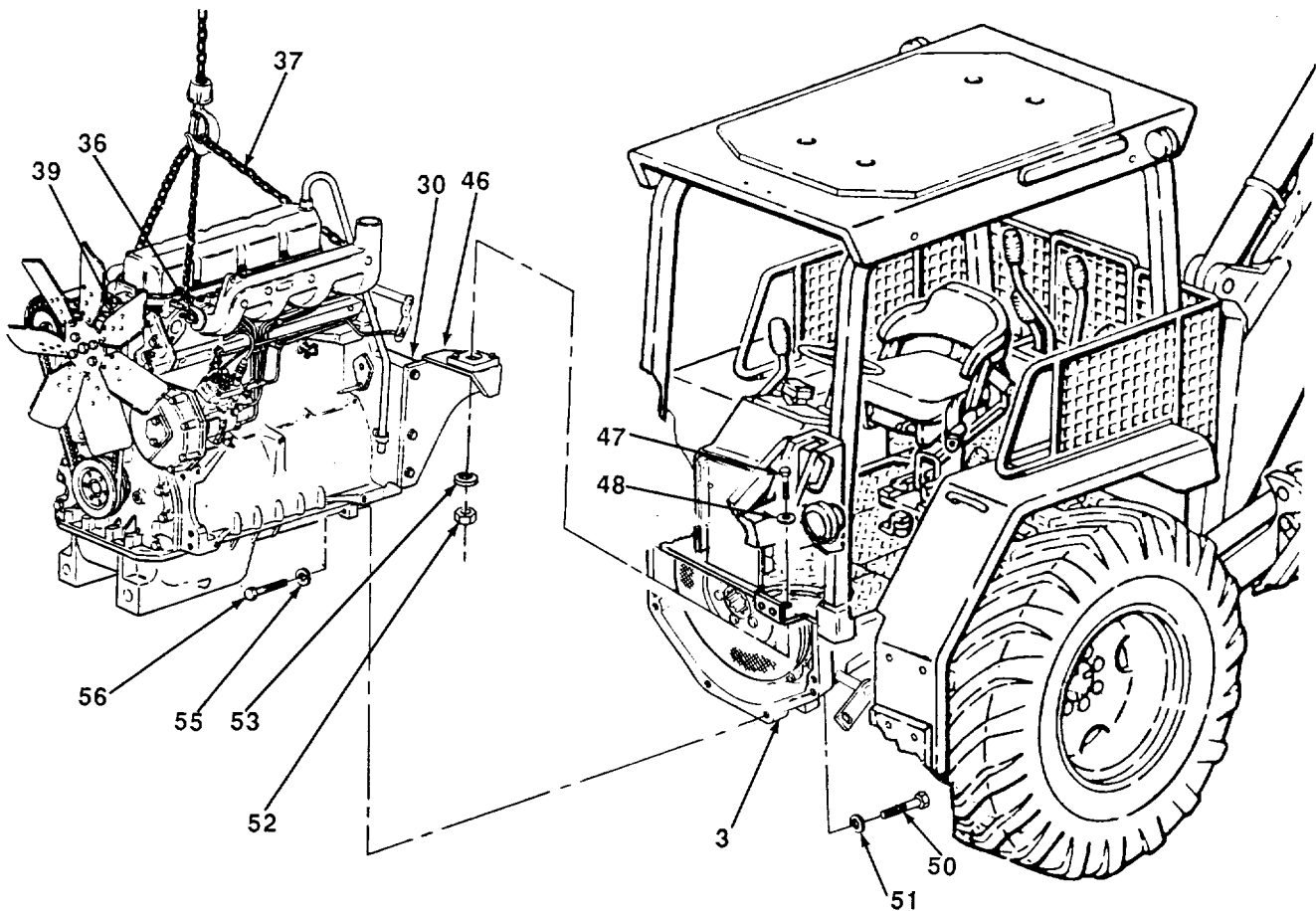

TA701231

3-3. ENGINE ASSEMBLY REPLACEMENT (Con't).

12. Position front crossmember (35) in place on canopy. Install four screws (42), new lockwashers (43), and washers (44).
13. Uncap tee (40) and remove plug from accumulator (45). Install pump pressure line-to-accumulator hose (41) to

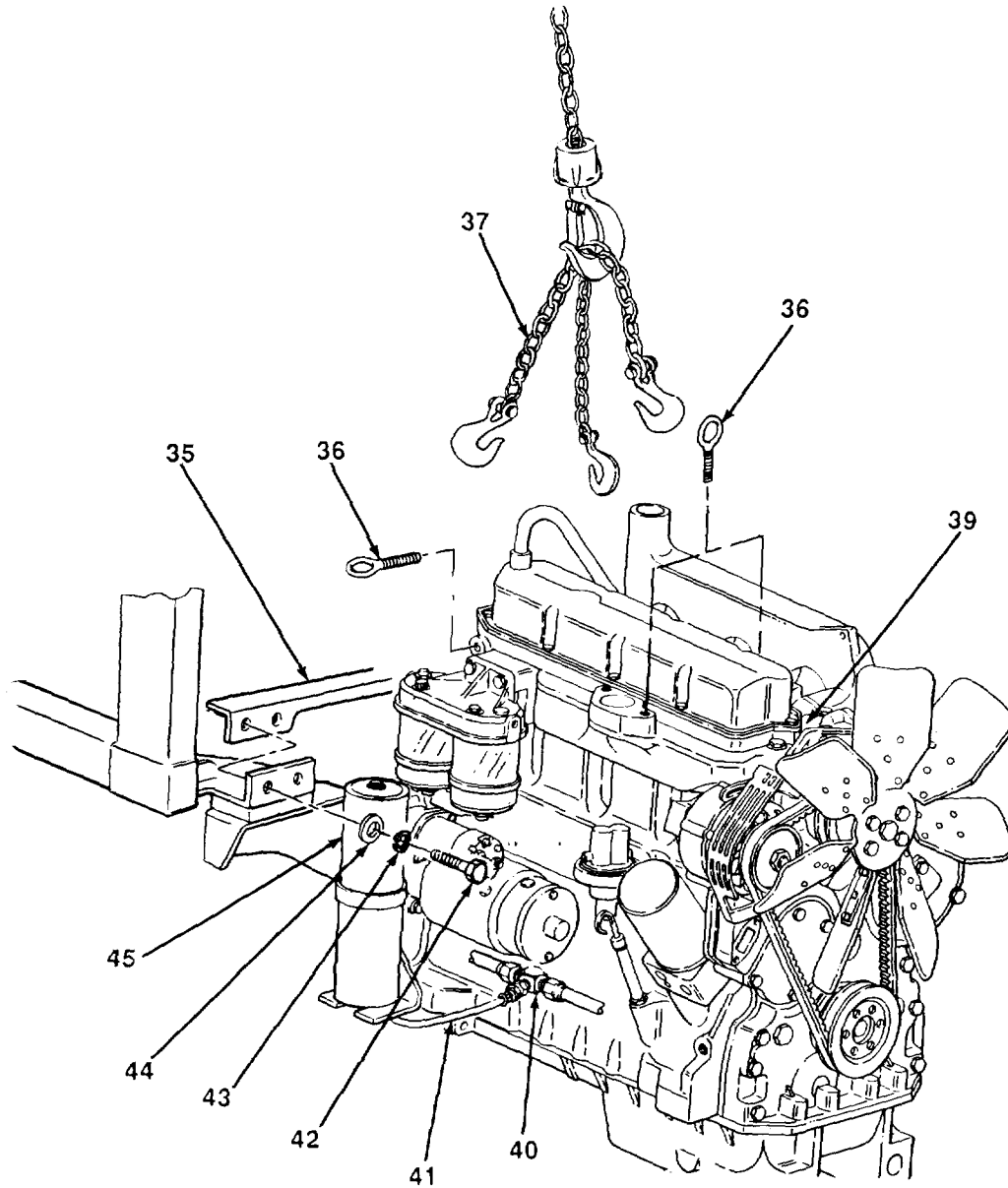

TA701232

3-3. ENGINE ASSEMBLY REPLACEMENT (Con't)

14. Install capillary tube (32) and water temperature sensor (34) in adapter (33). Tighten jamnut (31).

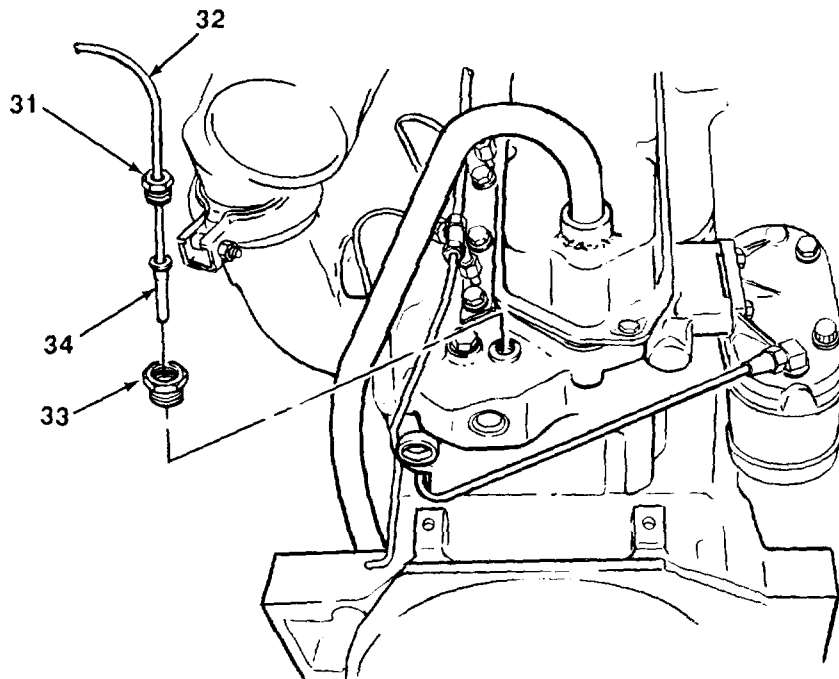

15. Install two screws (27) and new lockwashers (28) in flywheel housing (30) and cowl support (29).

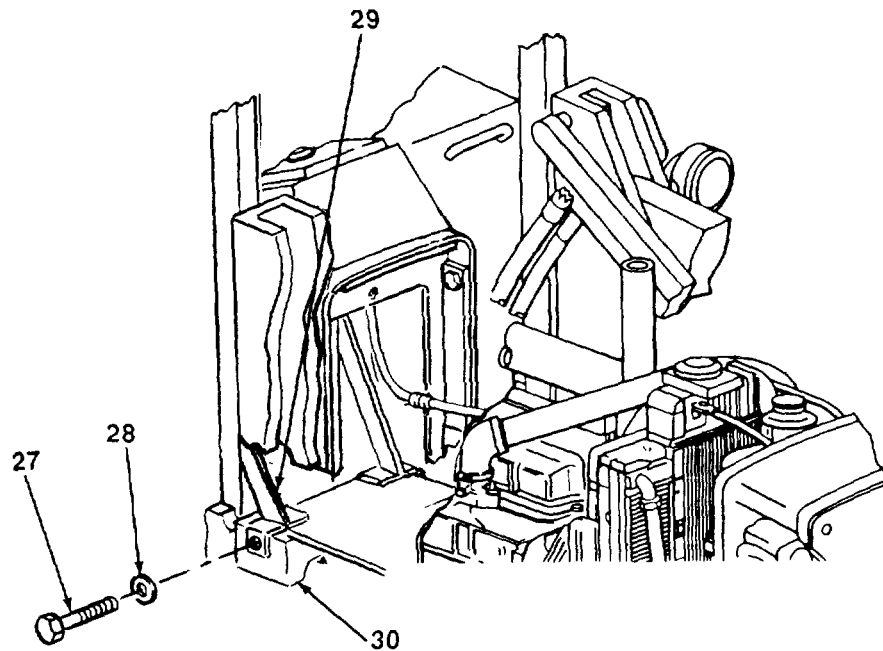

3-3. ENGINE ASSEMBLY REPLACEMENT (Con't).

- 16. Install main wiring harness fuel shutoff lead (24) in place on engine block (22). Install new tie-down bands (23) on main wiring harness fuel shutoff lead.
- 17. Position wiring harness terminal (26) in place on fuel injection pump shutoff solenoid terminal (17) and install new self-locking nut (25).
- 18. Remove adhesive tape from speed control rod (18) and engine block (22). Position speed control rod and washer (20) on shaft (19). Install new cotter pin (21) in shaft.

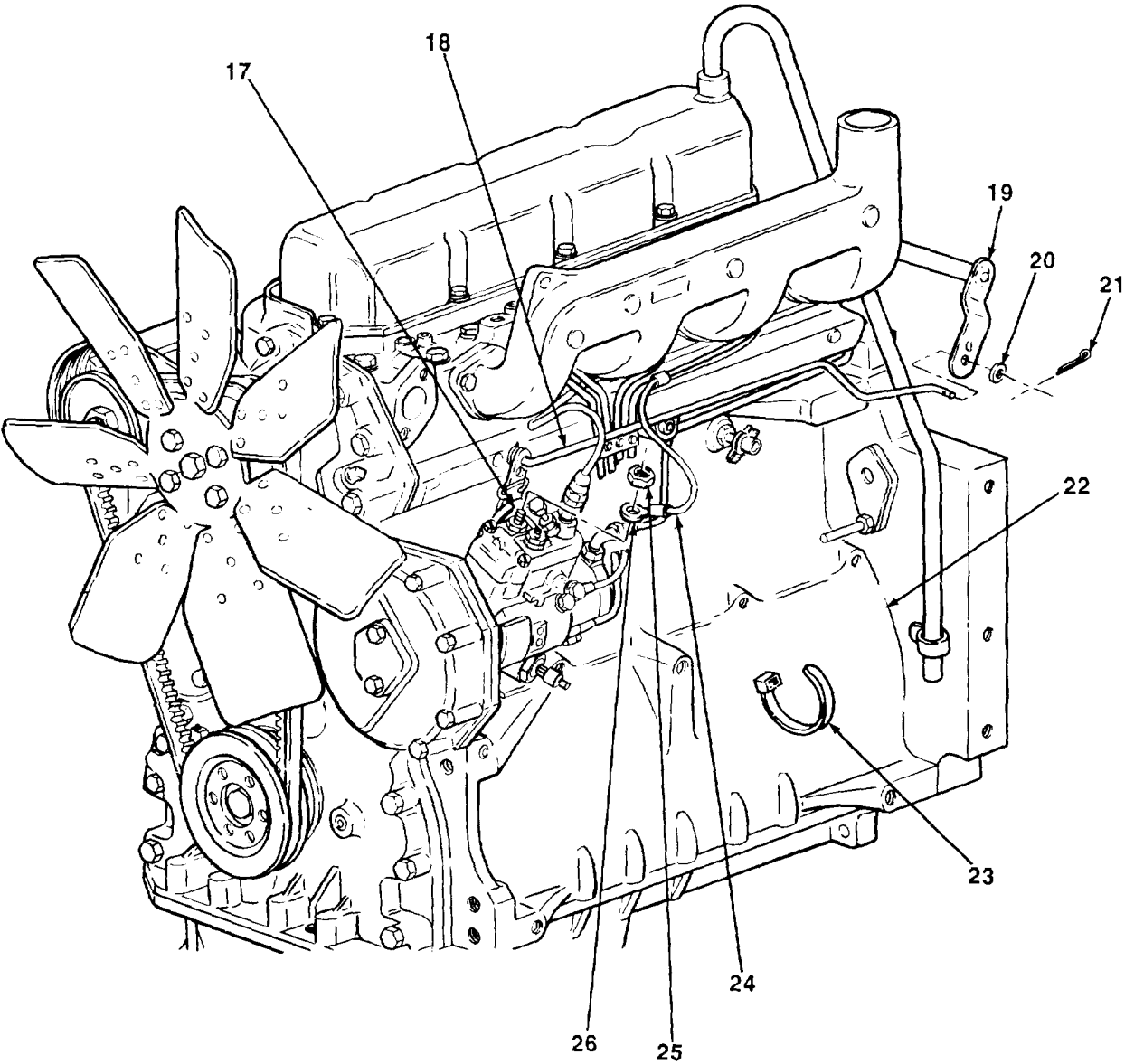

TA701234

3-3. ENGINE ASSEMBLY REPLACEMENT (Con't).

NOTE

Steps 19 and 20 apply only to loader backhoes with serial numbers 235786-235999.

- 19. Position engine starting aid fluid injection solenoid (8) and bracket (15) on solenoid bracket (9) and secure with two screws (14), washers (10 and 13), new lockwashers (11), and nuts (12). Connect ground terminal (4) to terminal (16).
- 20. Install solenoid lead terminal (6) on engine starting aid fluid injection solenoid terminals (5 and 7).

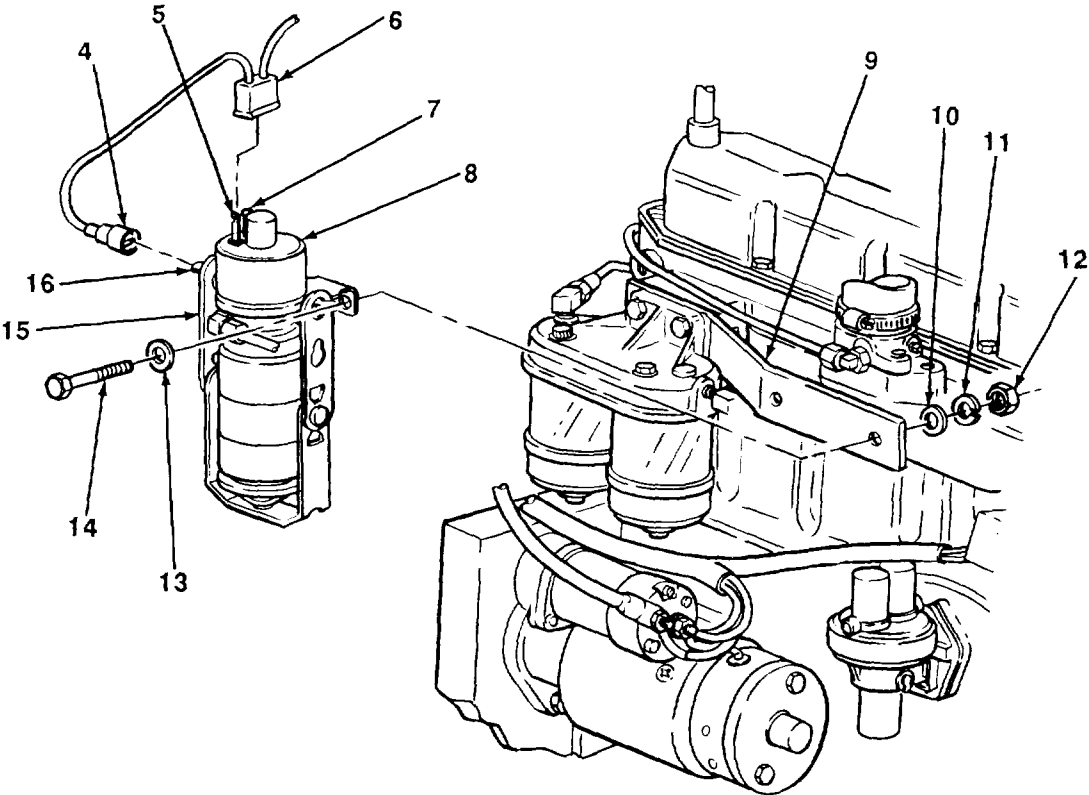

3-3. ENGINE ASSEMBLY REPLACEMENT (Con't).

21. Install tachometer drive cable (1) and new gasket (2) in reverser housing (3).

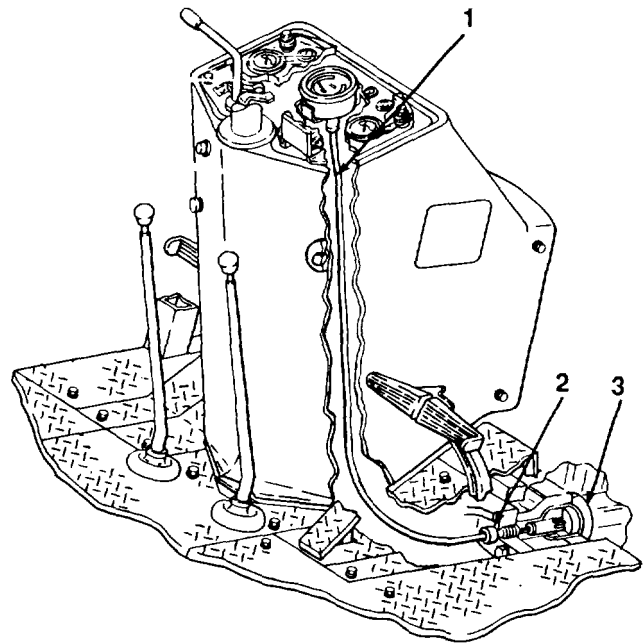
**FOLLOW-ON TASKS:**

- Connect starter (see TM5-2420-222-20).
- Connect alternator (see TM5-2420-222-20).
- Install right inner platform ramp (see TM5-2420-222-20).
- Install accumulator tee-to-steering valve oil line (see TM5-2420-222-20).
- Install electric horn and bracket (see TM5-2420-222-20).
- Install steering valve oil lines (see TM5-2420-222-20).
- Install muffler (see TM5-2420-222-20).
- Install frame assembly front support (see paragraph 12-1).

TA701236

3-4. ENGINE BLOCK MAINTENANCE.*This Task Covers:*

- | | |
|----------------------------|-------------|
| a. Disassembly | c. Repair |
| b. Cleaning and Inspection | d. Assembly |

*Initial Setup:***Equipment Conditions:****NOTE**

Perform the following only on loader backhoes equipped with engine coolant heater.

- Engine coolant heater hoses and fittings removed (see TM5-2420-222-20).
- Engine coolant heater removed (see TM5-2420-222-20).

NOTE

Perform the following on all loader backhoes.

- Engine assembly removed (see paragraph 3-3).
- Cylinder block plate removed (see paragraph 3-7).
- Starter removed (see TM5-2420-222-20).
- Lubricating cooler (engine oil cooler) removed (see TM 5-2420-222-20).
- Flywheel housing removed (see paragraph 3-10).
- Cylinder sleeves removed (see paragraph 3-5).
- Crankshaft removed (see paragraph 3-8).
- Liquid level gage removed (see TM 5-2420-222-20).

Materials/Parts:

- Engine oil (Item 25, Appendix B)
- Rags (Item 28, Appendix B)
- Dry cleaning solvent (Item 31, Appendix B)
- Nonelectrical wire (Item 44, Appendix B)
- One crankshaft
- One rear bearing

Tools/Test Equipment:

- General mechanic's tool kit
- Field automotive shop set

Personnel Required: Two**General Safety Instructions:**

- Dry cleaning solvent is flammable and must not be used near open flame. Use only in a well ventilated area.
- Compressed air used for cleaning purposes should never exceed 30 psi (207 kPa).
- Avoid contact with live steam.

a. DISASSEMBLY

1. Remove four pipe plugs (14) from engine block (1).

NOTE

For loader backhoes equipped with engine coolant heater, skip step 2.

2. Remove pipe plug (13) and draincock (12) from engine block (1).

CAUTION

Do not remove pins, Studs, plugs, or sleeve bushing in steps 3 through 7 unless damaged. Removal may damage parts.

3. Remove two pins (2 and 3) from engine block (1).
4. Remove two plugs (5) from engine block (1).
5. Using gear and bearing mechanical puller, remove sleeve bushing (6) from engine block (1).
6. Remove two pins (7) from engine block (1).

3-4. ENGINE BLOCK MAINTENANCE (Con't).

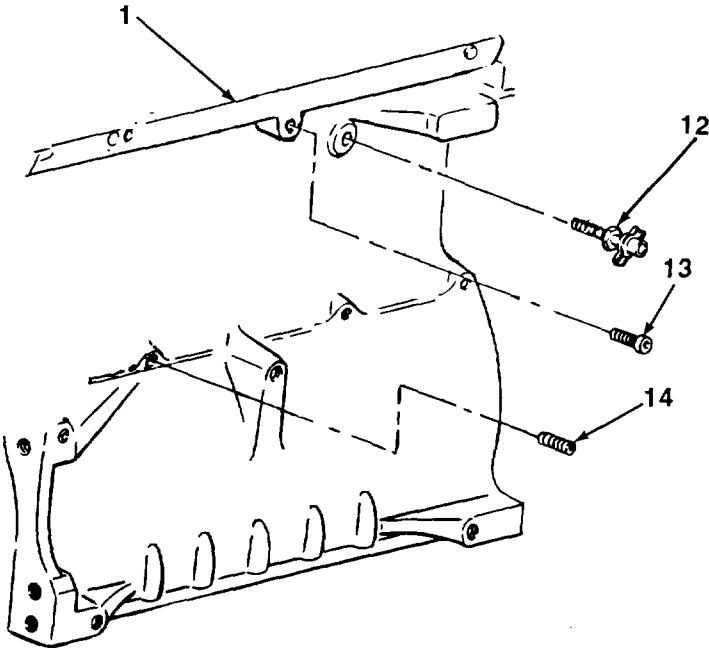
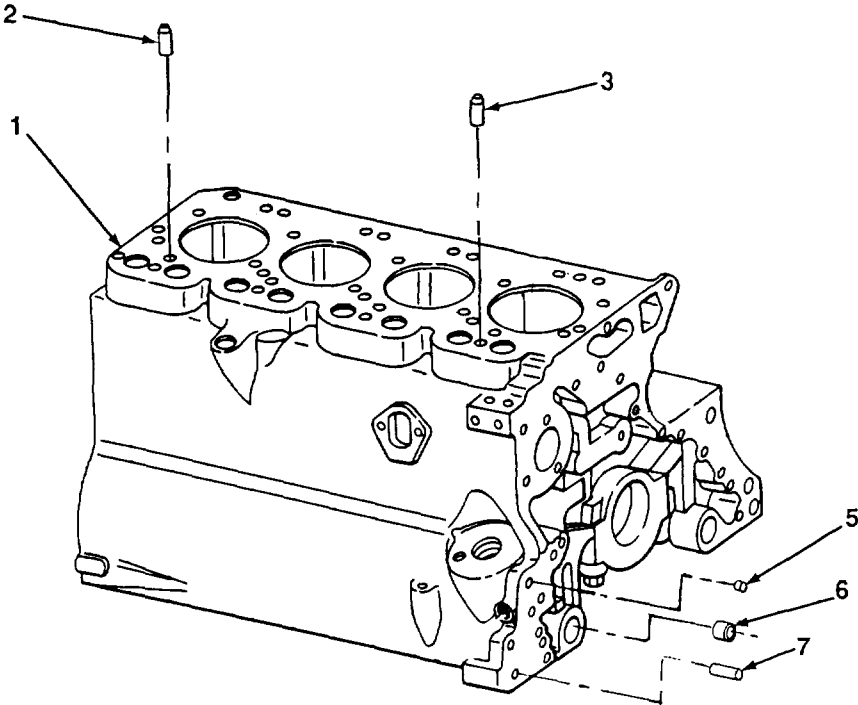

3-4. ENGINE BLOCK MAINTENANCE (Con't).

7. Remove three studs (4) from engine block (1).
8. Remove side plug (8) from engine block (1).
9. Remove four fluid restrictors (11) from engine block (1).
10. Remove pipe plug (10) from engine block (1).

CAUTION

Do not remove pins unless damaged. Removal may damage parts.

11. Remove two pins (9) from engine block (1).

b. CLEANING AND INSPECTION**WARNING**

Avoid contact with live steam. Live steam can burn skin, cause blindness, and cause other serious injury. Be sure to wear protective apron, gloves, and safety goggles when using live steam.

1. Using steam cleaner, clean all internal passages and external holes and recesses of engine block free of corrosion, scaling, and foreign matter.

WARNING

Compressed air used for cleaning or drying purposes, or for clearing restrictions, should never exceed 30 psi (207 kPa). Wear protective clothing (goggles/shield, gloves, etc.) and use caution to avoid injury to personnel.

2. Turn engine block so deposits will run out. Flush internal passages and external holes and recesses with clean water. Dry engine block with compressed air.

WARNING

Dry cleaning solvent, P-D-680, is toxic and flammable. Always wear protective goggles and gloves, and use only in a well-ventilated area. Avoid contact with skin, eyes, and clothes, and DO NOT breathe vapors. DO NOT use near open flame or excessive heat. The solvent's flash point is 100°F-138°F (38°C-59°C). If you become dizzy while using cleaning solvent, immediately get fresh air and medical help. If solvent contacts eyes, immediately wash your eyes and get medical aid.

3. Remove all gasket material from gasket surfaces, then wipe clean with dry cleaning solvent and rags.
4. Clean all other metal parts with dry cleaning solvent, then dry with rags.
5. Clean four fluid restrictors with dry cleaning solvent. Clear oil passages with nonelectrical wire. Wipe dry.

3-4. ENGINE BLOCK MAINTENANCE (Con't).

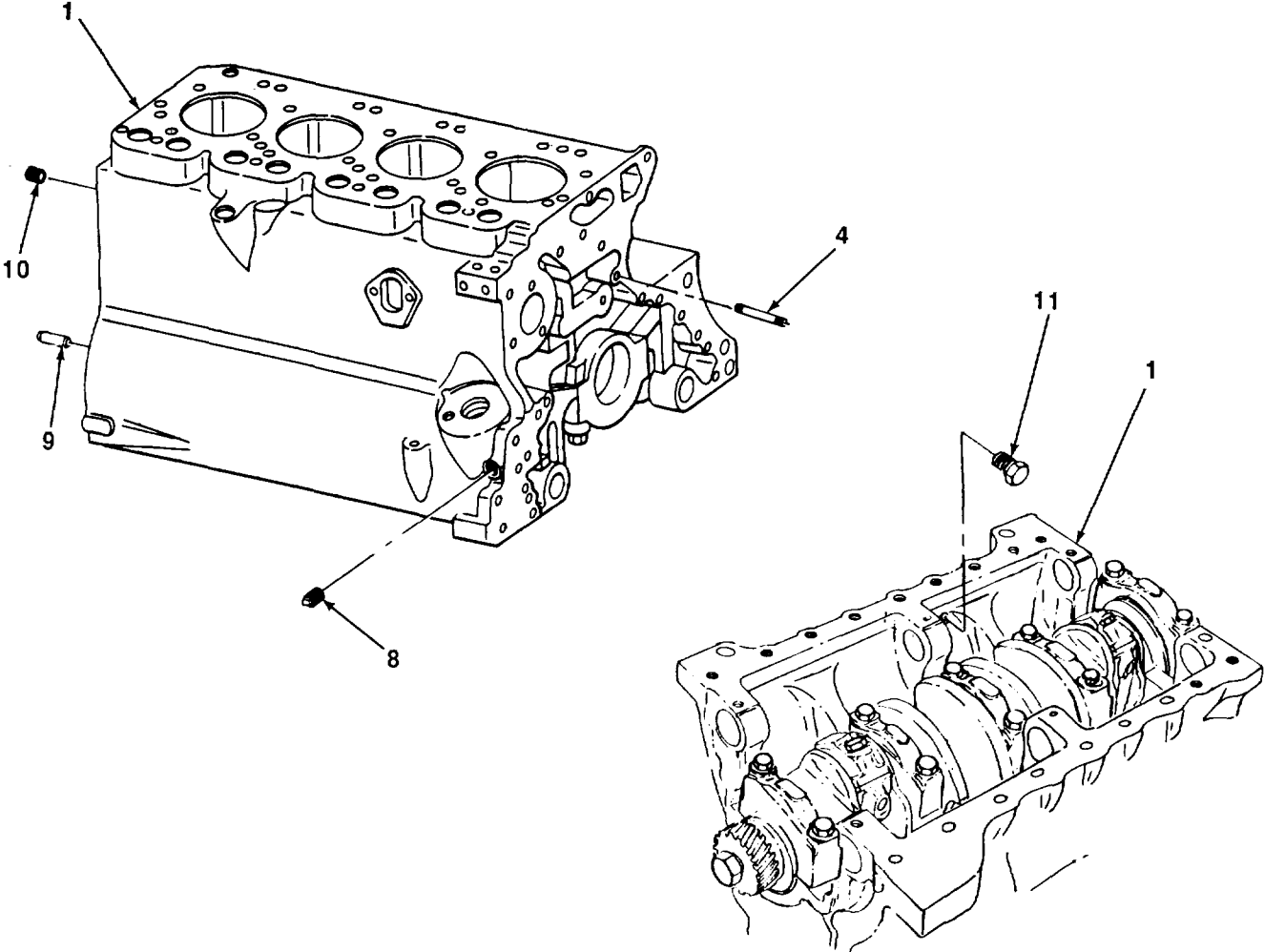

TA701238

3-4. ENGINE BLOCK MAINTENANCE (Con't).

6. Position four pillow block or main bearing caps (15) and rear pillow block cap (19) in place on engine block (1) in correct location as numbered, with pointer arrow facing toward camshaft side of engine block.
7. Coat threads of eight screws (17) with engine oil. Install eight screws and washers (16) in four pillow block or main bearing caps (15) and engine block (1). Torque screws to 85 lb.-ft. (115 N•m).
8. Coat threads of two screws (20) with engine oil. Install two screws and washers (21) in rear pillow block cap (19) and engine block (1). Torque screws to 85 lb.-ft. (115 N•m).
9. Using rod measuring kit, measure inside diameter of five main bearing bores. Inside diameter of each bore must be 3.3250-3.3260 in. (84.4550-84.4804 mm). If any bore is not within specified diameter, replace engine block (1).
10. Remove two screws (20), washers (21), and rear pillow block cap (19) from engine block (1).
11. Remove eight screws (17), washers (16), and four pillow block or main bearing caps (15) from engine block (1).

NOTE

Perform steps 12 through 29 to check engine block main bearing bore alignment. New bearings and a new crankshaft are used to eliminate any error which might exist from using worn bearings or crankshaft.

12. Lubricate four new bearing halves (23) and new rear bearing half (18) with engine oil. Slide bearing halves into position on engine block (1). Ensure that tangs on bearing halves fit in locking grooves in engine block and oil holes in bearings align with oil passages in engine block.
13. Lubricate four new bearing halves (24) and new rear bearing half (22) with engine oil. Slide bearing halves into position in pillow block or main bearing caps (15) and rear pillow block cap (19). Ensure that tangs on bearing halves fit in locking grooves in pillow block or main bearing caps and rear pillow block cap.

3-4. ENGINE BLOCK MAINTENANCE (Con't).

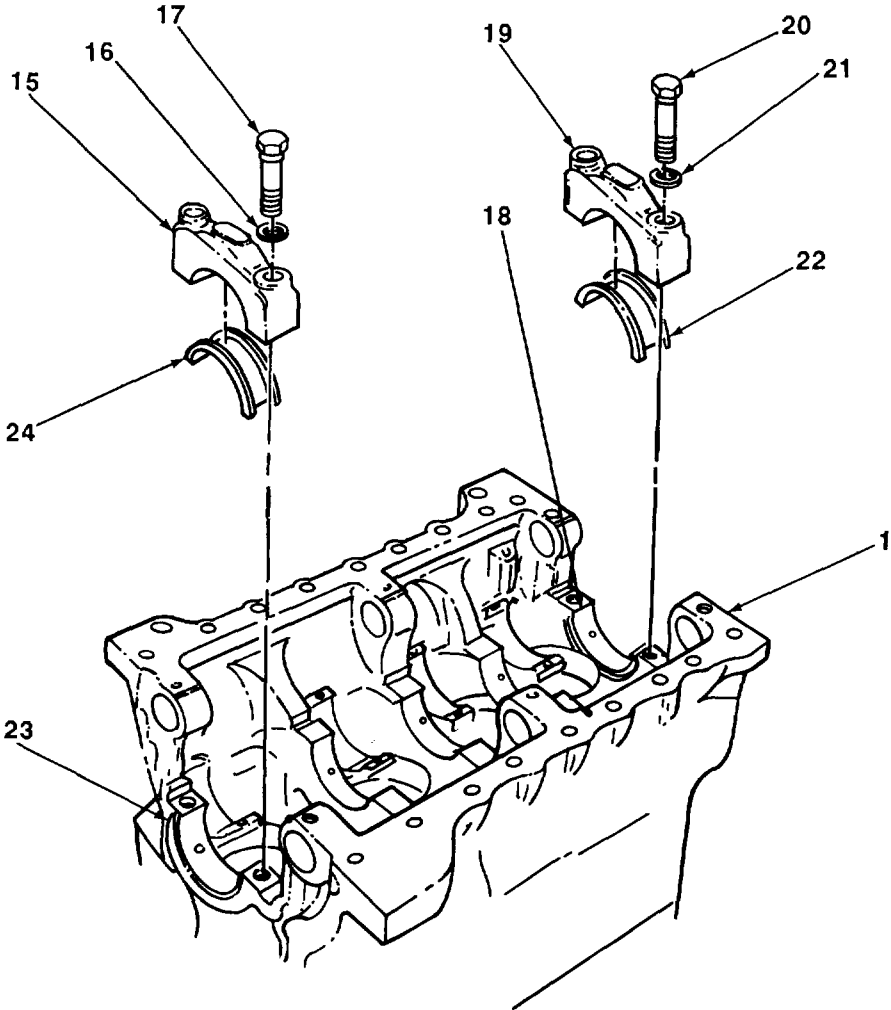

TA701239

3-4. ENGINE BLOCK MAINTENANCE (Con't).

WARNING

Use extreme caution when handling heavy parts. Lifting device is required when parts weigh over 50 lb (23 kg) for a single person lift, over 100 lb (45 kg) for a two person lift, and over 150 lb (68 kg) for a three or more person lift. Keep clear of heavy parts supported only by lifting device. Failure to follow this warning may cause serious injury or death to personnel.

CAUTION

Ensure that bearing faces are not damaged while installing crankshaft.

14. Using lifting device, lift and place new crankshaft (25) in position on engine block (1).
15. Position four pillow block or main bearing caps (15) with new bearing halves (24) in place on crankshaft (25) and engine block (1). Ensure that pillow block or main bearing caps are in correct location as numbered, with pointer arrow facing toward camshaft side of engine block.
16. Position rear pillow block cap (19) with new bearing half (22) in place on crankshaft (25). Ensure that pillow block cap is in correct location and pointer arrow is facing toward camshaft side of engine block (1).
17. Coat threads of eight screws (17) with engine oil. Install eight screws and washers (16) in four pillow block or main bearing caps (15) and engine block (1).
18. Coat threads of two screws (20) with engine oil. Install two screws and washers (21) in rear pillow block cap (19) and engine block (1).
19. Using ball-peen hammer and wood block, tap crankshaft (25) to the front and rear and align front and rear bearing half (18, 22, 23, and 24) flanges.
20. Torque screws (17 and 20) to 85 lb.-ft. (115 Nom).
21. Install screw to end of crankshaft (25). Using screw, turn crankshaft two full revolutions. Crankshaft must turn freely. If crankshaft does not turn freely, replace engine block (1).
22. Remove two screws (20), washers (21), and rear pillow block cap (19) with rear bearing half (22) from engine block (1). Remove rear bearing half from pillow block cap.
23. Remove eight screws (17), washers (16), and four pillow block or main bearing caps (15) with bearing halves (24) from engine block (1). Remove bearing halves from pillow block or main bearing caps.

WARNING

Use extreme caution when handling heavy parts. Lifting device is required when parts weigh over 50 lb (23 kg) for a single person lift, over 100 lb (45 kg) for a two person lift, and over 150 lb (68 kg) for a three or more person lift. Keep clear of heavy parts supported only by lifting device. Failure to follow this warning may cause serious injury or death to personnel.

24. Using lifting device, remove crankshaft (25) from engine block (1) and set on wood blocks.
25. Remove four new bearing halves (23) and new rear bearing half (18) from engine block (1).
26. Using rod measuring kit, measure inside diameter of control cam bores. Diameter must be 1.6245-1.6255 in. (41.2623-41.2877 mm). Ensure that measurement is taken with control cam bearings removed.
27. Using rod measuring kit, measure inside diameter of camshaft bore. Diameter must be 2.2042-2.2052 in. (55.9867-56.0121 mm).

3-4. ENGINE BLOCK MAINTENANCE (Con't).

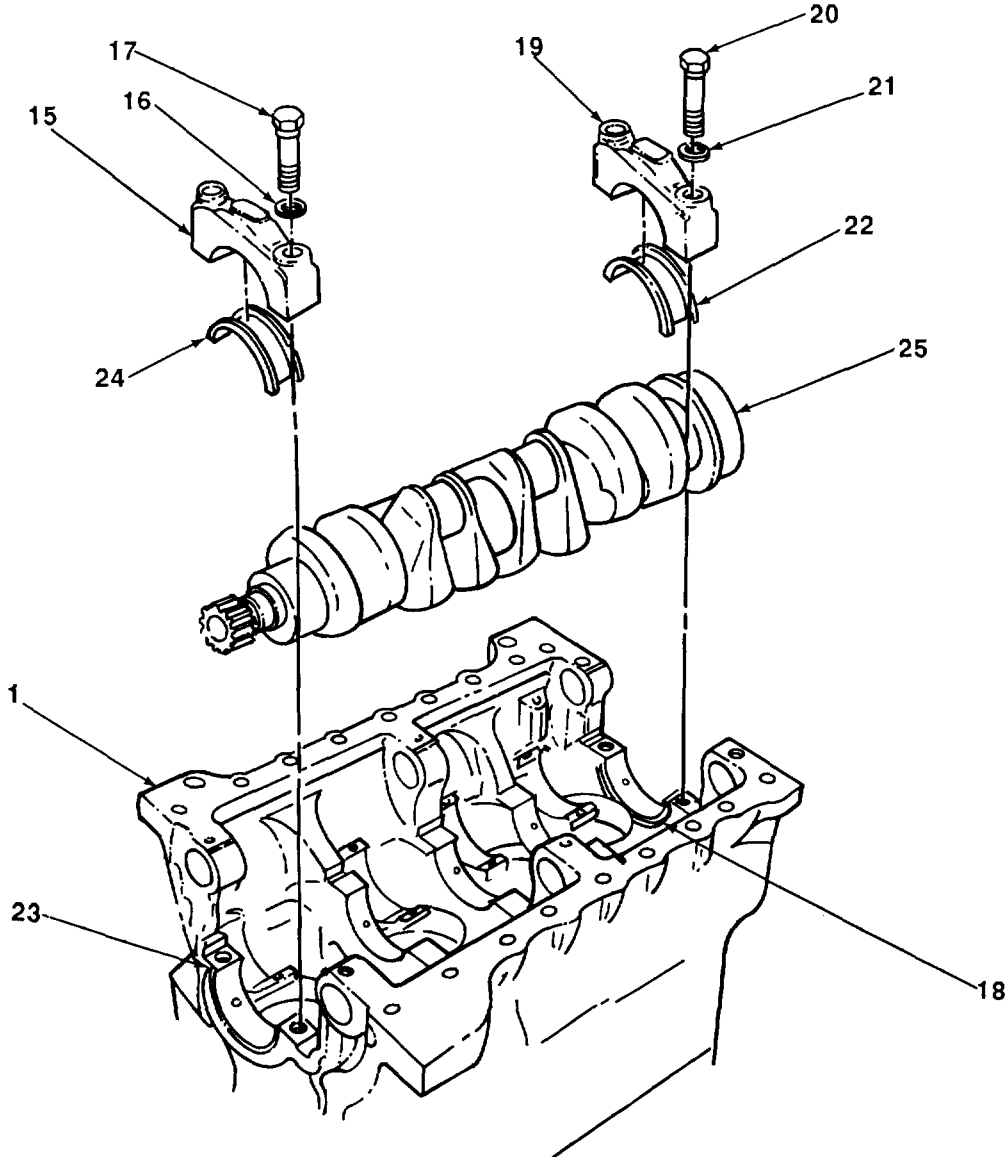

c. REPAIR

- 1. Restore damaged threads using screw threading set.
- 2. If high spots or burrs were found on gasket surfaces, remove with sharpening stone.

3-4. ENGINE BLOCK MAINTENANCE (Con't).

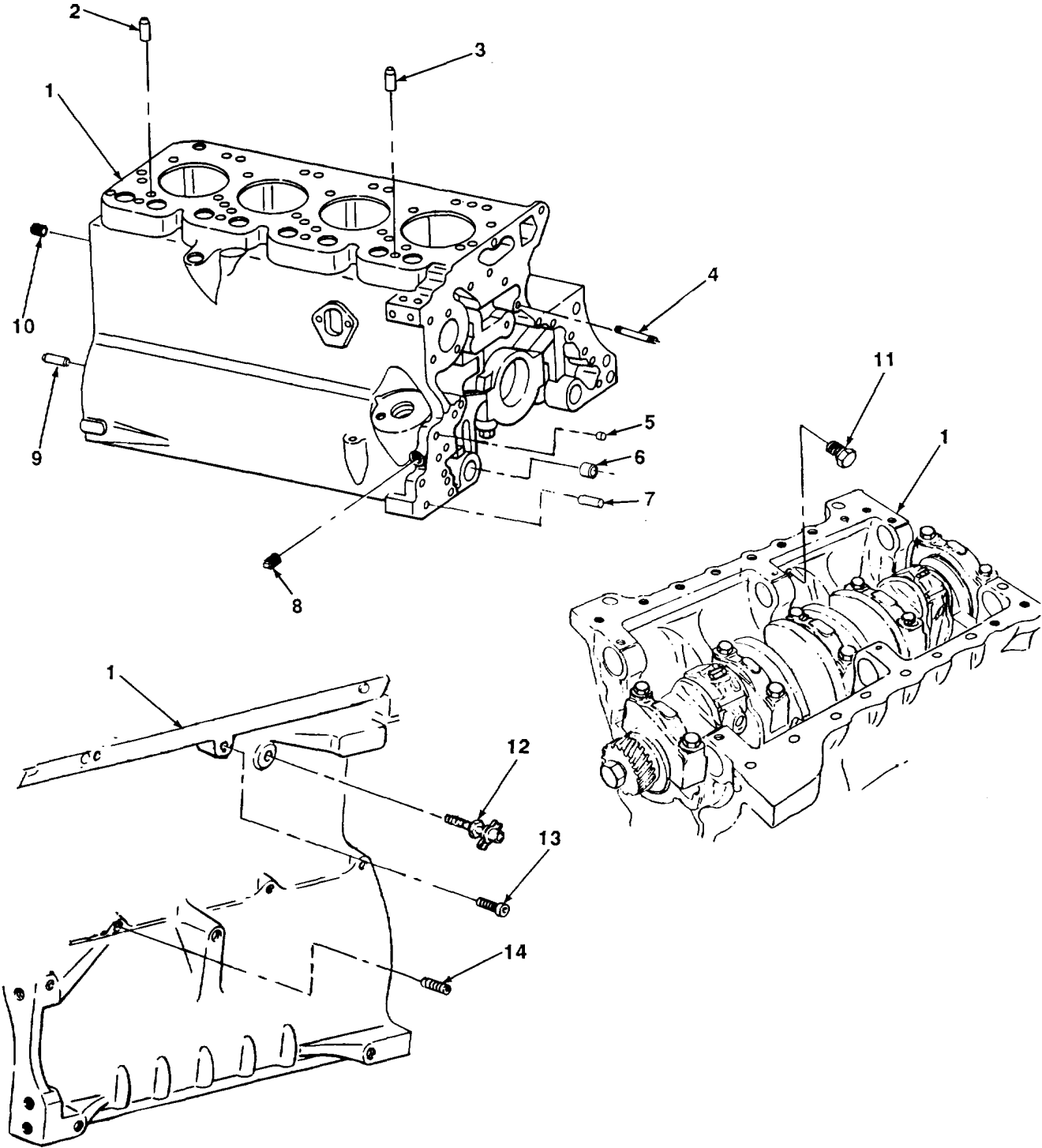

3-4. ENGINE BLOCK MAINTENANCE (Con't).

d. ASSEMBLY

1. If removed, install two pins (9) in engine block (1) with ball-peen hammer.
2. Install pipe plug (10), four fluid restrictors (11), and side plug (8) in engine block (1).
3. If removed, install three studs (4) in engine block (1) using stud remover and setter.
4. If removed, install two pins (7) in engine block (1) with ball-peen hammer.
5. If removed, install sleeve bushing (6) in engine block (1) using remover and installer and ball-peen hammer.
6. If removed, install two plugs (5) and two pins (2 and 3) in engine block (1) with ball-peen hammer.

NOTE

For loader backhoes equipped with engine coolant heater, skip step 7.

7. Install draincock (12) and pipe plug (13) in engine block (1).
8. Install four pipe plugs (14) in engine block (1).

FOLLOW-ON TASKS:**NOTE**

Perform the following on all loader backhoes.

- Install liquid level gage (see TM 5-2420-222-20).
- Install crankshaft (see paragraph 3-8).
- Install cylinder sleeves (see paragraph 3-5).
- Install flywheel housing (see paragraph 3-10).
- Install lubricating cooler (engine oil cooler) (see TM 5-2420-222-20).
- Install starter (see TM 5-2420-222-20).
- Install cylinder block plate (see paragraph 3-7).
- Install engine assembly (see paragraph 3-3).

NOTE

Perform the following only on loader backhoes equipped with engine coolant heater.

- Install engine coolant heater (see TM 5-2420-222-20).
- Install engine coolant heater hoses and fittings (see TM 5-2420-222-20).

3-5. CYLINDER SLEEVE MAINTENANCE.*This Task Covers:*

- | | |
|---------------|-----------------|
| a. Inspection | c. Removal |
| b. Repair | d. Installation |
| c. | |

*Initial Setup:***Equipment Conditions:**

- Engine assembly removed (see paragraph 3-3).
- Engine oil pan removed (see paragraph 3-20).
- Cylinder head removed (see paragraph 3-6).

Materials/Parts:

- Engine oil (Item 25, Appendix B)
- Rags (item 28, Appendix B)
- Dry cleaning solvent (Item 31, Appendix B)
- Marker tags (Item 32, Appendix B)
- One repair kit

Tools/Test Equipment

- General mechanic's tool kit
- Field automotive shop set

General Safety Instructions:

- Dry cleaning solvent is flammable and must not be used near open flame. Use only in a well-ventilated area.

NOTE

Loader backhoe engine has four cylinder sleeves. All four are maintained the same way. One is shown. Repeat procedure for each remaining cylinder sleeve.

a. INSPECTION

1. Using thickness gage, measure clearance between piston (2) and cylinder sleeve (1) at bottom of piston skirt. Clearance must be no greater than 0.006 in. (0.152 mm).
2. Remove piston and connecting rod (see paragraph 3-11).
3. Inspect cylinder sleeve (1) for cracks, scoring, glazing, discoloration, and abnormal wear.
4. Using rod measuring kit, measure inside diameter of cylinder sleeve (1) at right angle to direction of piston pin, 1 in. (2.54 cm) from bottom and top.
5. Subtract smaller measurement taken in step 1 from larger measurement taken in step 4 to determine taper. Taper must be no larger than 0.002 in. (0.051 mm). If taper is larger than specification, replace cylinder sleeves (1).
6. Using rod measuring kit, measure inside diameter of cylinder sleeve (1) at several locations, 1 in. (2.54 cm) from bottom and top.
7. Subtract smallest measurement from largest measurement taken in step 6. Difference is out-of-round. Out-of-round must be no larger than 0.002 in. (0.051 mm). If out-of-round is larger than specification, replace cylinder sleeves (1).

b. REPAIR

1. If glazing of cylinder sleeve (1) was found, deglaze using vertical honing machine.

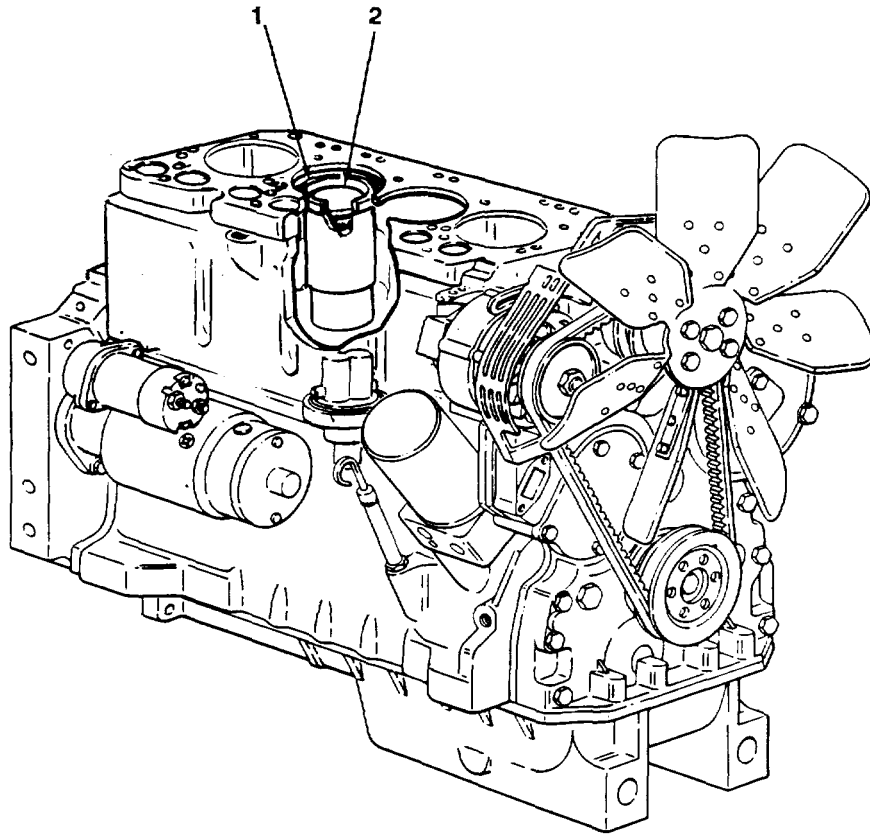
3-5. CYLINDER SLEEVE MAINTENANCE (Con't).**WARNING**

Dry cleaning solvent, P-D-680, is toxic and flammable. Always wear protective goggles and gloves, and use only in a well-ventilated area. Avoid contact with skin, eyes, and clothes, and **DO NOT** breathe vapors. **DO NOT** use near open flame or excessive heat. The solvent's flash point is 100°F-1380F (38°C-590C). If you become dizzy while using cleaning solvent, immediately get fresh air and medical help. If solvent contacts eyes, immediately wash your eyes and get medical aid.

2. Clean cylinder sleeve (1) with dry cleaning solvent and a paint brush, then wipe dry with a rag.

TA701242

3-5. CYLINDER SLEEVE MAINTENANCE (Con't).

c. REMOVAL**CAUTION**

Do not remove cylinder sleeve from engine block unless damaged or unless removal is required to gain access to engine block. Damage to cylinder sleeve or engine block may result.

NOTE

If it is necessary to replace one or more cylinder sleeves, replace all four.

1. Using cylinder sleeve remover and replacer, pull cylinder sleeve (1) from engine block (5). Discard cylinder sleeve.
2. Remove packing (3) from cylinder sleeve (1) and two packings (4) from engine block (5). Discard packings.

d. INSTALLATION**CAUTION**

- **Engine block bore and counterbore must be clean or cylinder sleeve flange will not seat properly. Damage to parts may result.**
- **Do not use excessive force when installing cylinder sleeve or flange may be damaged.**

1. Install new cylinder sleeve (1) in engine block (5) with wood block and ball-peen hammer.
2. Using micrometer depth gage, measure projection of cylinder sleeve (1) above top of engine block (5). Projection of cylinder sleeve must not exceed 0.004 in. (0.102 mm).
3. Using cylinder sleeve remover and replacer, remove cylinder sleeve (1) from engine block (5).
4. Slide new packing (3) into position on cylinder sleeve (1). Ensure that packing is not crimped or twisted.
5. Slide two new packings (4) into position in engine block (5). Ensure that packings are not twisted or sticking out of grooves in engine block.
6. Coat packings (3 and 4) and engine block (5) bore with engine oil.

CAUTION

Install cylinder sleeve in engine block slowly. Failure to do so may twist packings and cause damage to parts.

NOTE

Cylinder sleeve will extend above engine block more than normal because packings have not been compressed.

7. Slide cylinder sleeve (1) with packing (3) in engine block (5). Tap cylinder sleeve into position using wood block and ball-peen hammer. Coat cylinder sleeve with engine oil.

3-5. CYLINDER SLEEVE MAINTENANCE (Con't).

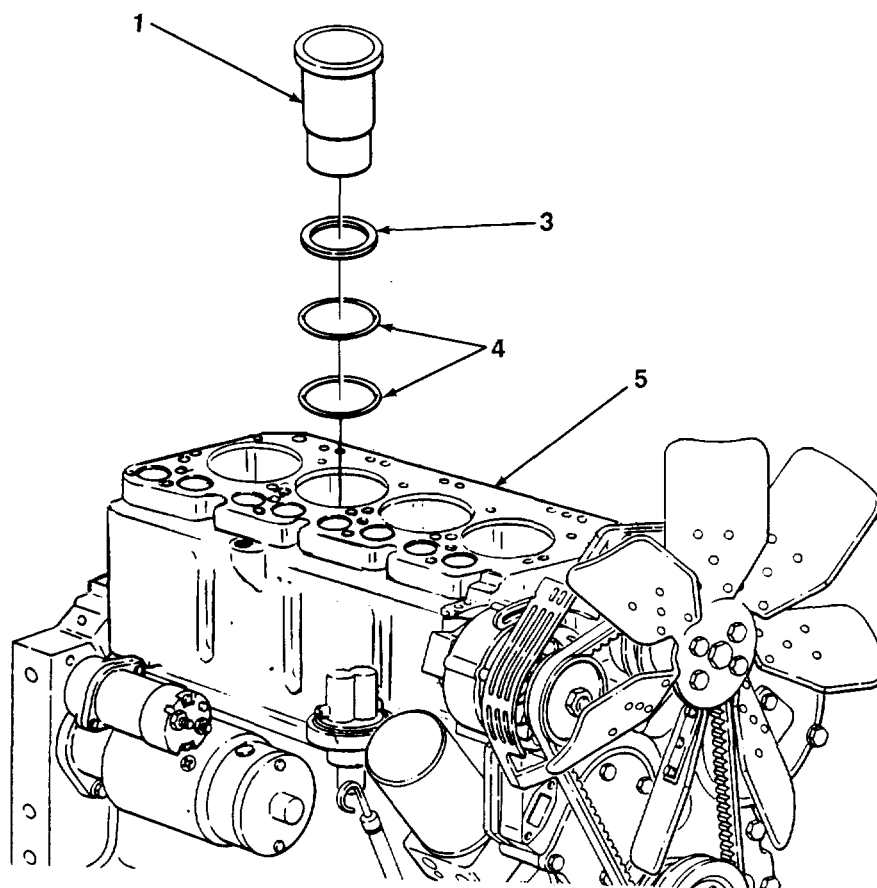
**FOLLOW-ON TASKS:**

- Install pistons and connecting rods (see paragraph 3-11).
- Install cylinder head (see paragraph 3-6).
- Install engine oil pan (see paragraph 3-20).
- Install engine assembly (see paragraph 3-3).

TA701243

3-6. CYLINDER HEAD MAINTENANCE.*This Task Covers:*

- | | |
|----------------------------|-----------------|
| a. Removal | d. Repair |
| b. Disassembly | e. Assembly |
| c. Cleaning and Inspection | f. Installation |
| d. | |

*Initial Setup:***Equipment Conditions:**

- Rocker arm cover removed (see TM 5-2420-222-20).
- Rocker arm, shaft, and pushrods removed (see paragraph 3-13).
- Engine starting aid fluid injection tube and fittings removed (see TM 5-2420-222-20).
- Air inlet housing removed (see TM 5-2420-222-20).
- Exhaust manifold removed (see TM 5-2420-222-20).
- Fuel injection nozzles removed (see TM 5-2420-222-20).

Tools/Test Equipment:

- General mechanic's tool kit
- Field automotive shop set
- Steam cleaner

Materials/Parts:

- Wire brush (Item 4, Appendix B)
- Carbon removing compound (Item 8, Appendix B)
- Engine oil (Item 25, Appendix B)
- Rags (Item 28, Appendix B)
- Dry cleaning solvent (Item 31, Appendix B)
- One gasket

Personnel Required: Two**General Safety Instructions:**

- Dry cleaning solvent is flammable and must not be used near open flame. Use only in a well-ventilated area.
- Compressed air used for cleaning purposes should never exceed 30 psi (207 kPa).
- Avoid contact with live steam.

a. REMOVAL

1. Remove 18 capscrews (2) and washers (1) from cylinder head (3) and engine block (6).
2. Remove cylinder head (3) and gasket (5) from engine block (6). Discard gasket.

b. DISASSEMBLY**NOTE**

Do not remove expansion plugs unless damaged or defective. Removal may damage parts.

Drive two expansion plugs (4) out of cylinder head (3).

3-6. CYLINDER HEAD MAINTENANCE (Con't).

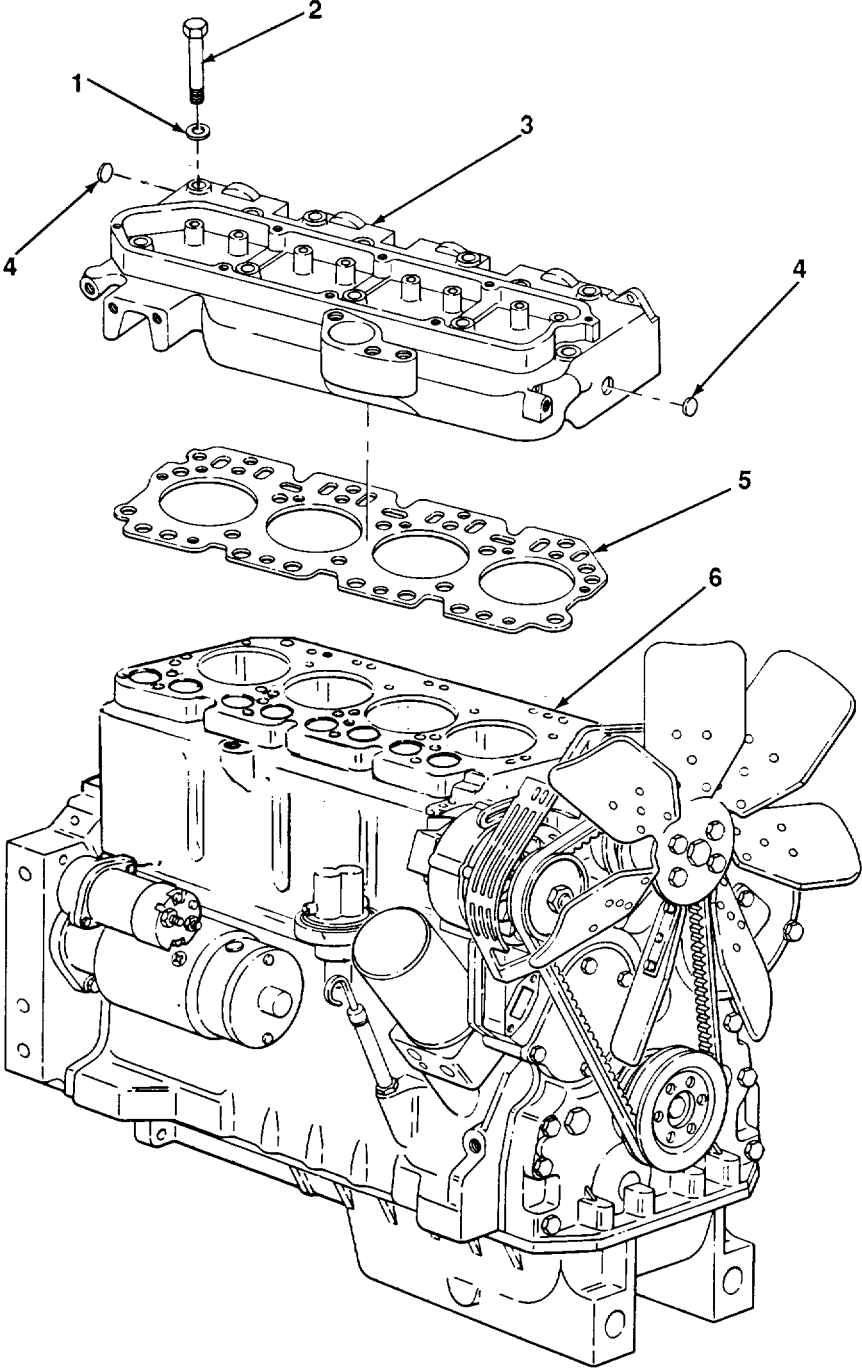

TA701244

3-6. CYLINDER HEAD MAINTENANCE (Con't).**c. CLEANING AND INSPECTION****WARNING**

- Carbon removing compound is a corrosive liquid. If splashed in eyes, it can cause blindness. If splashed on skin, it can cause serious burns. Be sure to wear safety goggles or lenses, rubber apron, and rubber gloves. If accidentally splashed in eyes or on skin, flush with clean, cool water, refer to FM 21-11 for first aid information, and get medical attention immediately.
- Avoid contact with live steam. Live steam can burn skin, cause blindness, and cause other serious injury. Be sure to wear protective apron, gloves, and safety goggles when using live steam.
- Compressed air used for cleaning or drying purposes, or for clearing restrictions, should never exceed 30 psi (207 kPa). Wear protective clothing (goggles/shield, gloves, etc.) and use caution to avoid injury to personnel.

1. Soak cylinder head overnight in carbon removing compound. Using wire brush and hot water, clean off carbon deposits. Using 1/2 in. tube brush and hot water, clean valve guides. Dry thoroughly with compressed air.

WARNING

Dry cleaning solvent, P-D-680, is toxic and flammable. Always wear protective goggles and gloves, and use only in a well-ventilated area. Avoid contact with skin, eyes, and clothes, and DO NOT breathe vapors. DO NOT use near open flame or excessive heat. The solvent's flash point is 100°F-138°F (38°C-59°C). If you become dizzy while using cleaning solvent, immediately get fresh air and medical help. If solvent contacts eyes, immediately wash your eyes and get medical aid.

2. Clean all other metal parts with dry cleaning solvent and wipe dry with a clean, dry rag.
3. Check cylinder head for cracks, breaks, warping, damaged threads, and abnormal wear.
4. Using square edge and thickness gage, check flatness of bottom mounting surface of cylinder head.
5. Remove and inspect valves (see paragraph 3-12).
6. Install valves (see paragraph 3-12).

d. REPAIR

1. Restore damaged threads using screw threading set.
2. If bottom mounting surface of cylinder head (3) was not flat, use grinding equipment to flatten cylinder head.

e. ASSEMBLY

If removed, position two expansion plugs (4) in place in cylinder head (3). Using ball-peen hammer, tap expansion plugs into position.

f. INSTALLATION

1. With the aid of an assistant, position new gasket (5) and cylinder head (3) in place on engine block (6).

3-6. CYLINDER HEAD MAINTENANCE (Con't).

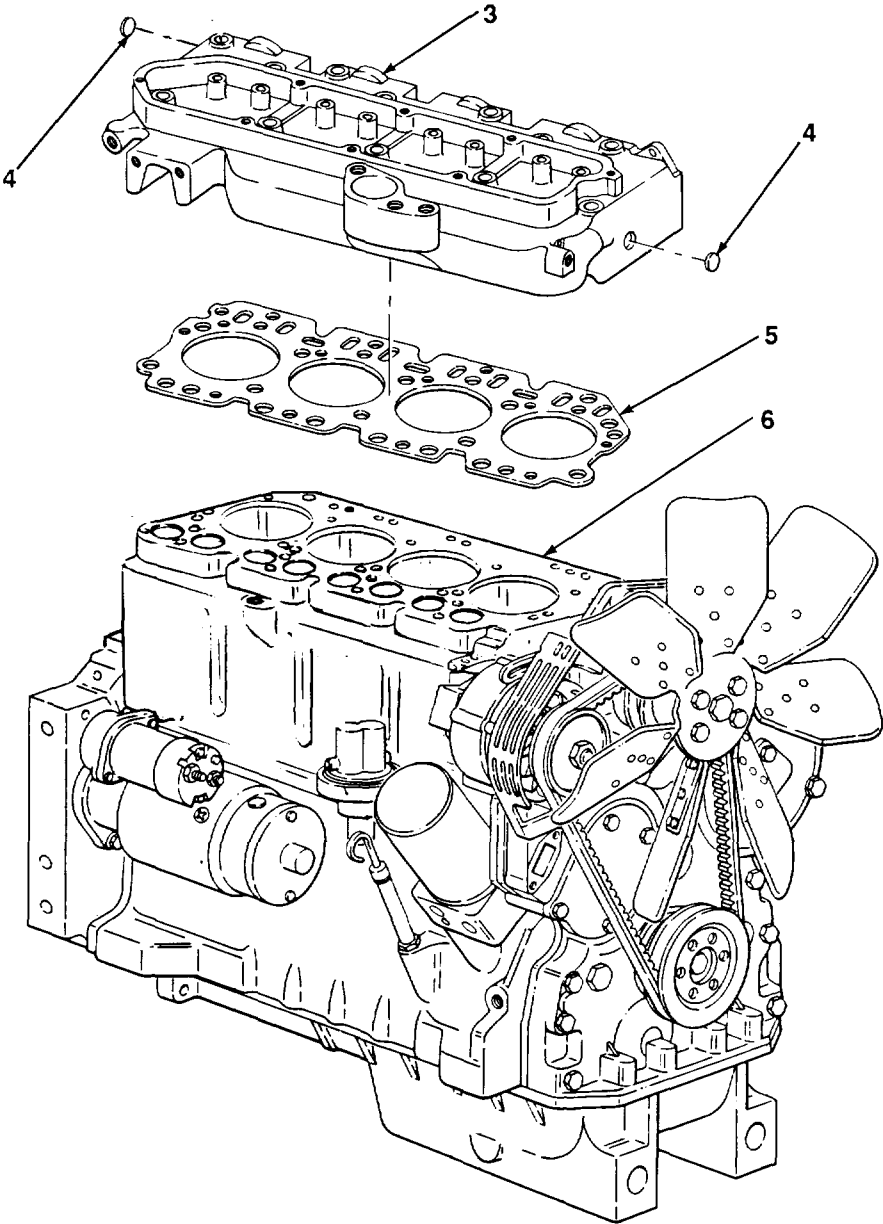

3-6. CYLINDER HEAD MAINTENANCE (Con't).

2. Coat threads of capscrews (2) with engine oil. Install 18 washers (1) and capscrews in cylinder head (3) and engine block (6). Torque ca screws in sequence shown to 95 lb.-ft. (129 N•m).

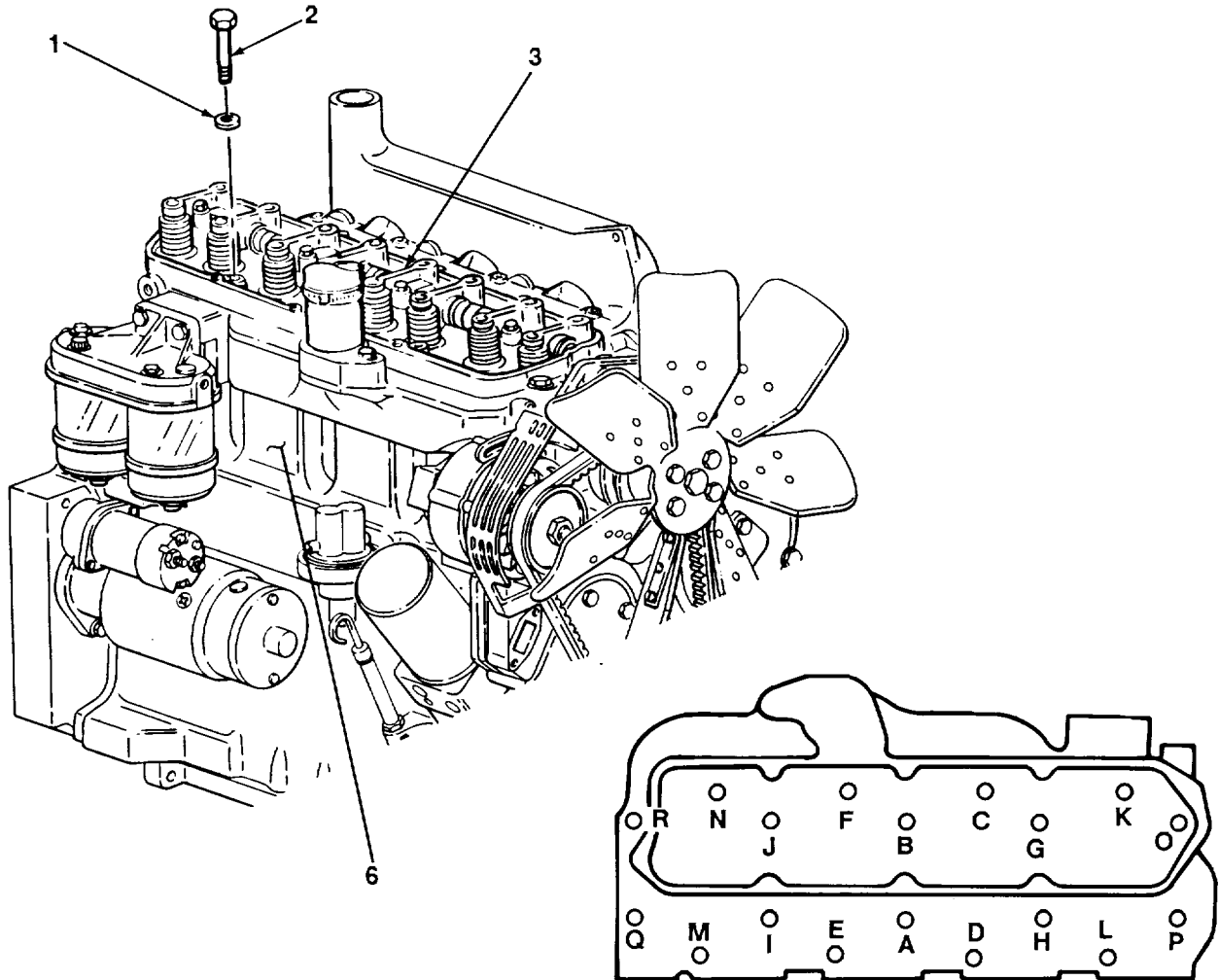

TORQUE SEQUENCE

FOLLOW-ON TASKS:

- Install fuel injection nozzles (see TM 5-2420-222-20).
- Install exhaust manifold (see TM 5-2420-222-20).
- Install air inlet housing (see TM 5-2420-222-20).
- Install engine starting aid fluid injection tube and fittings (see TM 5-2420-222-20).
- Install rocker arm, shaft, and pushrods (see paragraph 3-13).
- Install rocker arm cover (see TM 5-2420-222-20).

TA701246

3-7. CYLINDER BLOCK PLATE REPLACEMENT.

This Task Covers:

- | | | | |
|----|-------------------------|----|--------------|
| a. | Removal | c. | Installation |
| b. | Cleaning and Inspection | | |
-

*Initial Setup:***Equipment Conditions:**

- Fuel pump helical gear removed (see paragraph 5-3).
- Idler gears removed (see paragraph 3-15).
- Camshaft removed (see paragraph 3-17).
- Control cams removed (see paragraph 3-19).
- Fuel metering pump removed (see paragraph 5-2).

Tools/Test Equipment:

- General mechanic's tool kit
- Field automotive shop set

Materials/Parts:

- Rags (Item 28, Appendix B)
- Dry cleaning solvent (Item 31, Appendix B)
- One gasket
- Five lockwashers

General Safety Instructions:

- Dry cleaning solvent is flammable and must not be used near open flame. Use only in a well-ventilated area.
-

3-7. CYLINDER BLOCK PLATE REPLACEMENT (Con't).**a. REMOVAL**

1. Remove five machine screws (5) and lockwashers (4) from cylinder block plate (6) and engine block (1). Discard lockwashers.
2. Lift cylinder block plate (6) and gasket (2) off engine block (1). Discard gasket.

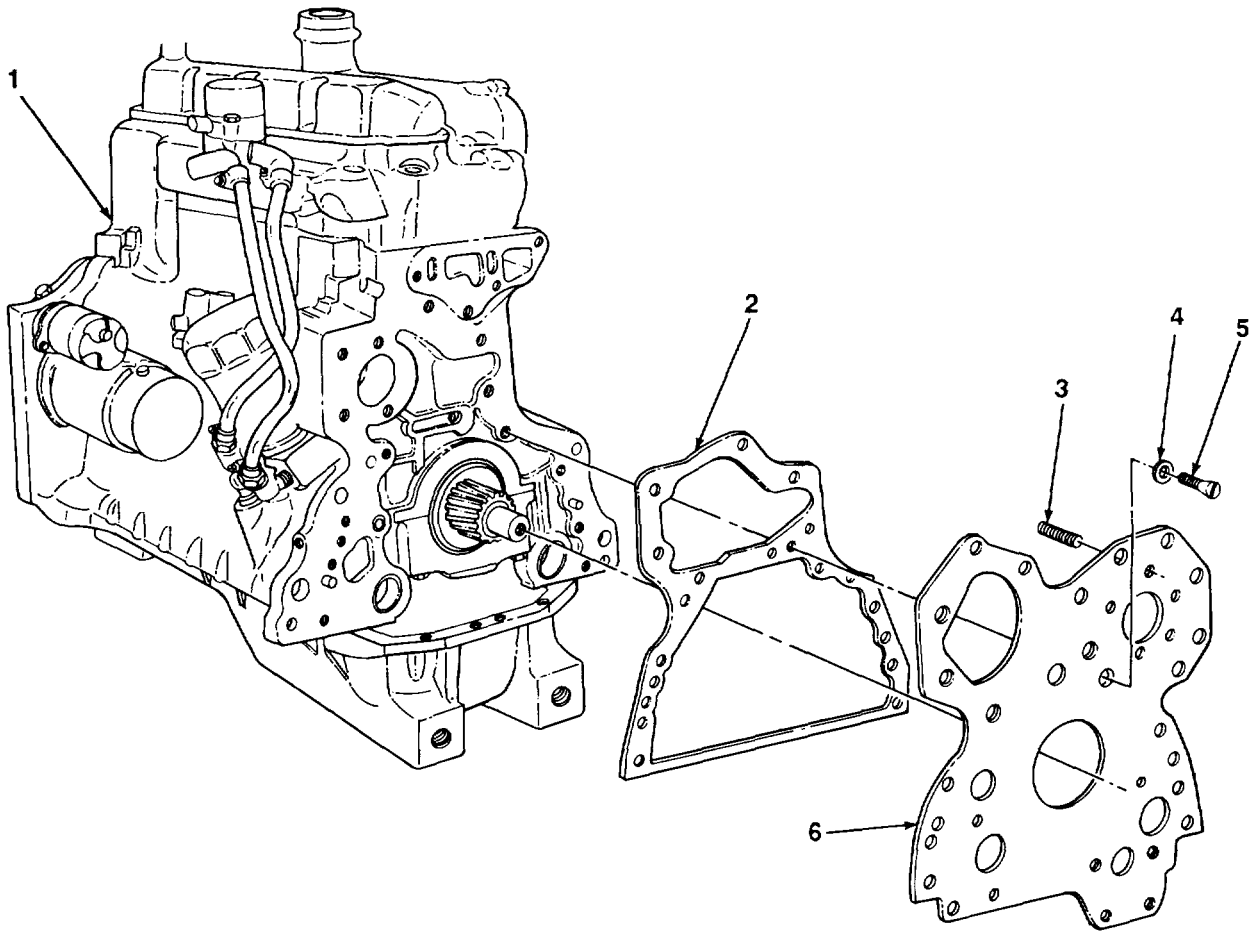
**b. CLEANING AND INSPECTION****WARNING**

Dry cleaning solvent, P-D-680, is toxic and flammable. Always wear protective goggles and gloves, and use only in a well-ventilated area. Avoid contact with skin, eyes, and clothes, and DO NOT breathe vapors. DO NOT use near open flame or excessive heat. The solvent's flash point is 100°F-138°F (38°C-59°C). If you become dizzy while using cleaning solvent, immediately get fresh air and medical help. If solvent contacts eyes, immediately wash your eyes and get medical aid.

1. Clean cylinder block plate with dry cleaning solvent and a clean rag. Remove any remaining gasket material from cylinder block plate and engine block.

3-7. CYLINDER BLOCK PLATE REPLACEMENT (Con't).

2. Inspect cylinder block plate for cracks, breaks, and abnormal bends.
3. Inspect five setscrews (3) for cracks, bends, or damaged threads. If damaged, remove setscrews.
4. Inspect threaded holes in cylinder block plate for damaged threads. Restore damaged threads using screw threading set.

c. INSTALLATION

1. Position cylinder block plate (6) and new gasket (2) in place on engine block (1).
2. Install five machine screws (5) and new lockwashers (4) in cylinder block plate (6) and engine block (1). Torque machine screws to 25 lb.-ft. (34 N-m)

FOLLOW-ON TASKS:

- Install fuel metering pump (see paragraph 5-2).
- Install control cams (see paragraph 3-19).
- Install camshaft (see paragraph 3-17).
- Install idler gears (see paragraph 3-15).
- Install fuel pump helical gear (see paragraph 5-3).

3-8. CRANKSHAFT MAINTENANCE.*This Task Covers:*

- | | |
|----------------------------|-----------------|
| a. Removal | d. Assembly |
| b. Disassembly | e. Installation |
| c. Cleaning and Inspection | |

*Initial Setup:***Equipment Conditions:**

- Engine assembly removed (see paragraph 3-3).
- Flywheel housing removed (see paragraph 3-10).
- Engine oil pan removed (see paragraph 3-20).
- Fuel injection nozzles removed (see TM 5-2420-222-20).
- Cylinder block plate removed (see paragraph 3-7).
- Cylinder block plate removed (see paragraph 3-7).

Tools/Test Equipment:

- General mechanic's tool kit
- Field automotive shop set

Personnel Required: Two**Materials/Parts:**

- Engine oil (Item 25, Appendix B)
- Rags (Item 28, Appendix B)
- Dry cleaning solvent (Item 31, Appendix B)
- Marker tags (Item 32, Appendix B)

General Safety Instructions:

- Dry cleaning solvent is flammable and must not be used near open flame. Use only in a well-ventilated area.
- Compressed air used for cleaning purposes should never exceed 30 psi (207 kPa).
 - Hot oil gives off highly flammable fumes and must not be used near open flame.

a. REMOVAL

1. Using pry bar and dial indicator, pry crankshaft (14) forward in engine block (3) and measure end play. End play must be 0.0020-0.0230 in. (0.0508-0.5842 mm).

NOTE

- **The engine has four connecting rod bearing caps. Removal of all four is the same. One is shown. Repeat steps 2 through 9 for remaining connecting rod bearing caps.**
- **In step 2, use screw removed from crankshaft pulley.**

2. Install screw (15) in end of crankshaft (14).
3. Using screw (15), rotate crankshaft (14) until desired connecting rod bearing cap (5) is accessible.
4. Using cylinder ridge reamer, remove carbon ridge from cylinder sleeve (13).
5. Remove two bolts (7) and washers (6) from connecting rod bearing cap (5) and connecting rod (11).

CAUTION

Lift connecting rod bearing cap out carefully. Careless removal may allow lower sleeve bearing half to fall from bearing cap causing damage to lower sleeve bearing half and crankshaft journal.

NOTE

Note location of stampings on connecting rod bearing cap to ensure proper installation.

6. Remove connecting rod bearing cap (5) with assembled lower sleeve bearing half (4) from connecting rod (11) and crankshaft (14).

3-8. CRANKSHAFT MAINTENANCE (Con't).

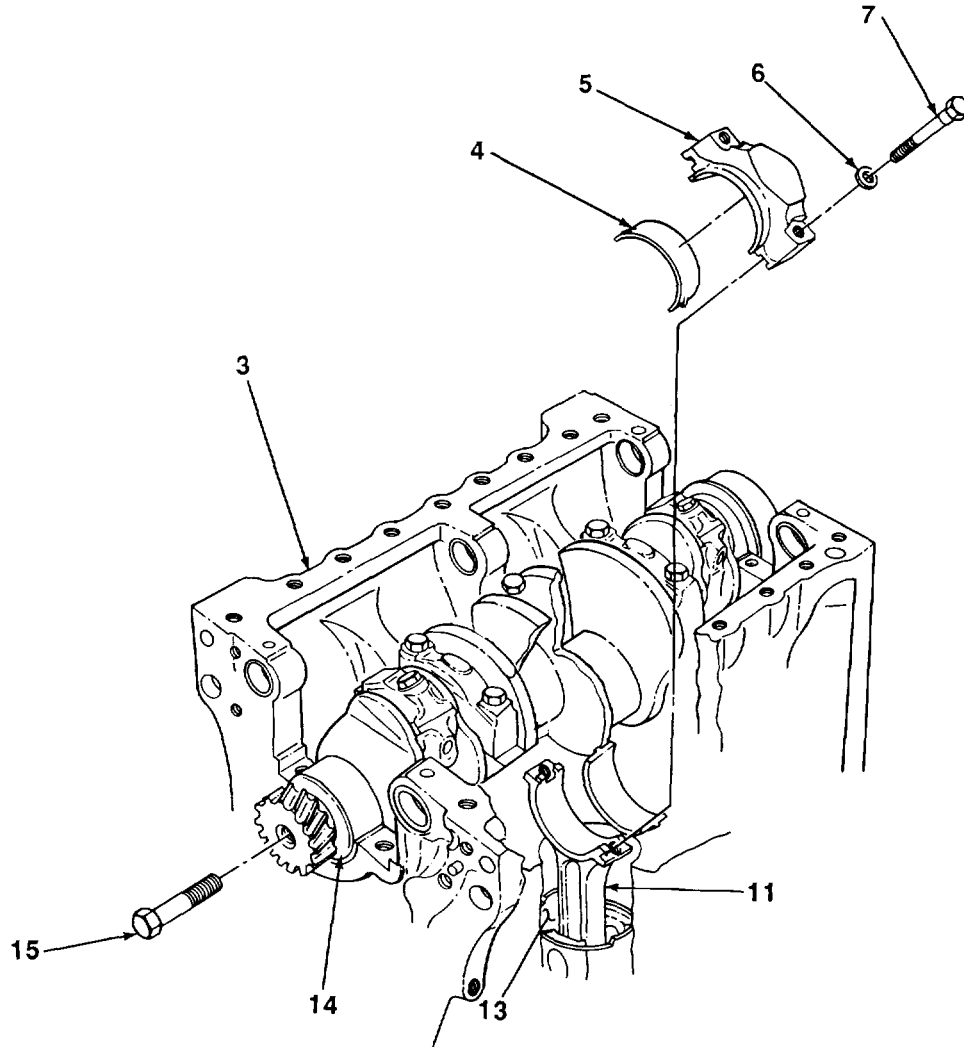

7. Slide lower sleeve bearing half (4) out of connecting rod bearing cap (5).
8. Using handle of hammer, drive connecting rod (11) with assembled piston (12) clear of crankshaft (14).
9. Slide upper sleeve bearing half (10) out of connecting rod (11).
10. Remove screw (15) from end of crankshaft (14).

TA701248

3-8. CRANKSHAFT MAINTENANCE (Con't).**CAUTION**

Main bearings and main bearing caps must be installed in same location from which they are removed. Failure to do so may damage parts.

NOTE

Engine has five main bearing caps. Removal of all five is the same. One is shown. Repeat steps 11 through 13 for remaining four main bearing caps.

11. Using center punch and hammer, match-mark main bearing cap (8) to engine block (3) to ensure proper installation.
12. Remove two screws (2) and washers (1) from main bearing cap (8) and engine block (3).

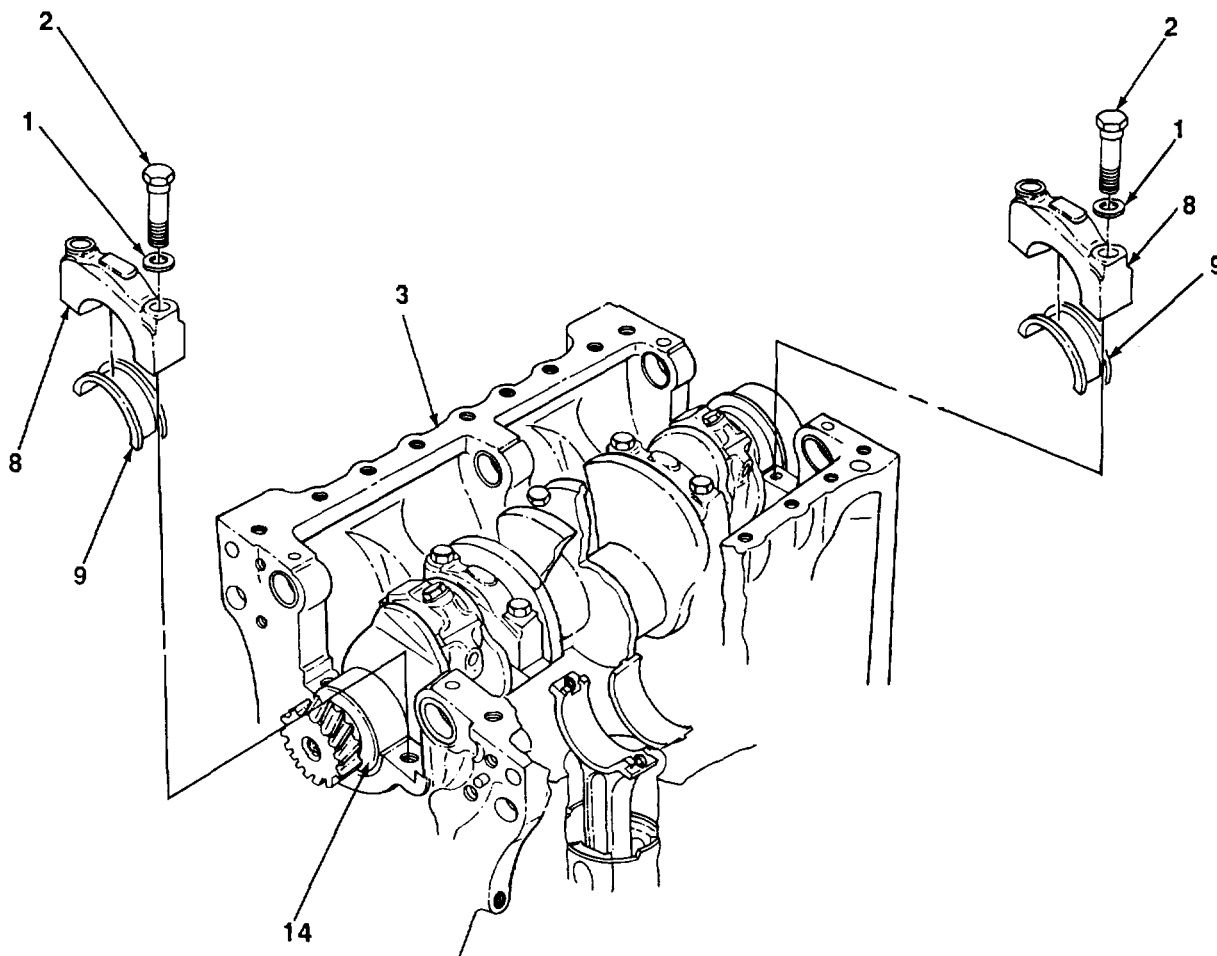

TA701249

3-8. CRANKSHAFT MAINTENANCE (Con't).**CAUTION**

- Lift main bearing cap out carefully. Careless removal may allow lower sleeve bearing half to fall from bearing cap causing damage to lower sleeve bearing half and crankshaft journal.
- Lower sleeve bearing halves must be installed in same main bearing caps from which they are removed. Failure to do so may damage parts.

13. Remove main bearing cap (8) with lower sleeve bearing half (9) from engine block (3) and crankshaft (14). Remove lower sleeve bearing half from main bearing cap.

CAUTION

Ensure that crankshaft is lifted straight out of engine block. Knocking crankshaft against engine block may damage parts.

NOTE

Upper sleeve bearing halves are different sizes. Note location to ensure proper installation.

14. With the aid of an assistant, lift crankshaft (14) and five upper sleeve bearing halves (18) out of engine block (3).

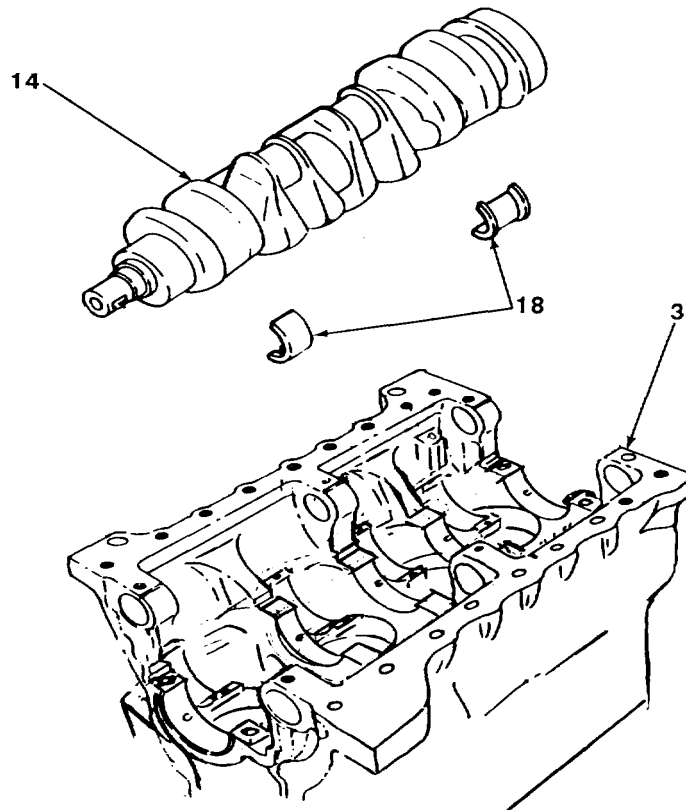

TA701250

3-8. CRANKSHAFT MAINTENANCE (Con't).**b. DISASSEMBLY****CAUTION**

Do not remove straight pin unless damaged. Removal may damage parts.

1. Using stud remover and setter, remove straight pin (17) from crankshaft (14).
2. Using mechanical gear and bearing puller, remove spur gear (16) from crankshaft (14).
3. Remove woodruff key (19) from crankshaft (14).

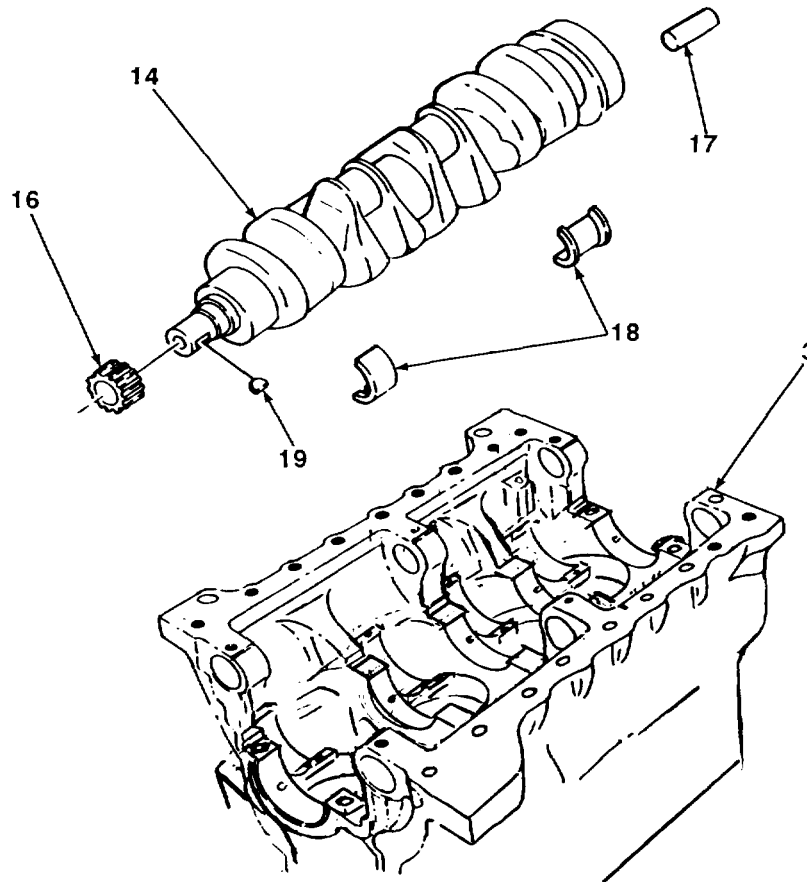

3-8. CRANKSHAFT MAINTENANCE (Con't).**c. CLEANING AND INSPECTION****WARNING**

- **Dry cleaning solvent, P-D-680, is toxic and flammable. Always wear protective goggles and gloves, and use only in a well-ventilated area. Avoid contact with skin, eyes, and clothes, and DO NOT breathe vapors. DO NOT use near open flame or excessive heat. The solvent's flash point is 100°F-138°F (38°C-59°C). If you become dizzy while using cleaning solvent, immediately get fresh air and medical help. If solvent contacts eyes, immediately wash your eyes and get medical aid.**
- **Compressed air used for cleaning or drying purposes, or for clearing restrictions, should never exceed 30 psi (207 kPa). Wear protective clothing (goggles/shield, gloves, etc.) and use caution to avoid injury to personnel.**

1. Clean oil passages of crankshaft with dry cleaning solvent and X in. wire brush, then dry with compressed air.
2. Clean all other metal parts with dry cleaning solvent and dry with compressed air and rags.
3. Check all bearing journals of crankshaft for ridges, grooves, and discoloration caused by overheating. If crankshaft has been overheated, heat treatment has been destroyed and crankshaft must be replaced.
4. Using micrometer caliper set, measure and record diameter of each crankshaft main bearing journal at several locations. Diameter must be 3.1230-3.1240 in. (79.3242-79.3496 mm).
5. Subtract the smallest measurement from the largest measurement taken in step 4. The difference is out-of-round. Out-of-round must be no larger than 0.0030 in. (0.0762 mm).
6. Using micrometer caliper set, measure and note record diameter starting at one end of each crankshaft main bearing journal and at 1 in. (2.54 cm) intervals along length of journal. Difference between each measurement is taper. Taper must be no larger than 0.0010 in. (0.0254 mm) per 1 in. (2.54 cm) of crankshaft main bearing journal.
7. Using micrometer caliper set, measure and record diameter of each crankshaft connecting rod bearing journal at several locations. Diameter must be 2.7480-2.7890 in. (69.7992-70.8406 mm).
8. Subtract the smallest measurement from the largest measurement taken in step 7. The difference is out-of-round. Out-of-round must be no larger than 0.0030 in. (0.0762 mm).
9. Using micrometer caliper set, measure and record diameter starting at one end of each crankshaft connecting rod bearing journal and at 1 in. (2.54 cm) intervals along length of journal. Difference between each measurement is taper. Taper must be no larger than 0.0010 in. (0.0254 mm) per 1 in. (2.54 cm) of crankshaft connecting rod bearing journal.

CAUTION

When installing main bearings and main bearing caps on engine block, ensure that they are installed in same location from which they were removed. Failure to do so may damage parts.

NOTE

Measurement of inside diameter of one main bearing is described in steps 10 through 18. Repeat steps for other four main bearings.

10. Place upper sleeve bearing half (18) in position on engine block (3). Ensure that tang on upper sleeve bearing half fits in locking groove in engine block.

3-8. CRANKSHAFT MAINTENANCE (Con't).

11. Place lower sleeve bearing half (9) in position on main bearing cap (8). Ensure that tang on lower sleeve bearing half fits in locking groove in main bearing cap.
12. Place main bearing cap (8) and assembled lower sleeve bearing half (9) in position with match-marks aligned.
13. Coat threads of two screws (2) with engine oil. Install two screws and washers (1) in main bearing cap (8) and engine block (3). Torque screws to 85 lb.-ft. (115 N•m).
14. Using rod measuring kit, measure and record inside diameter of upper and lower sleeve bearing halves (9 and 18) in engine block (3). Diameter must be 3.1256-3.1296 in. (79.3902-79.4918 mm).
15. Subtract largest crankshaft main bearing Journal measurement taken in step 4 from sleeve bearing halves measurement taken in step 14. Difference between the two measurements is clearance. Clearance must be 0.0016-0.0060 in. (0.0406-0.1524 mm).

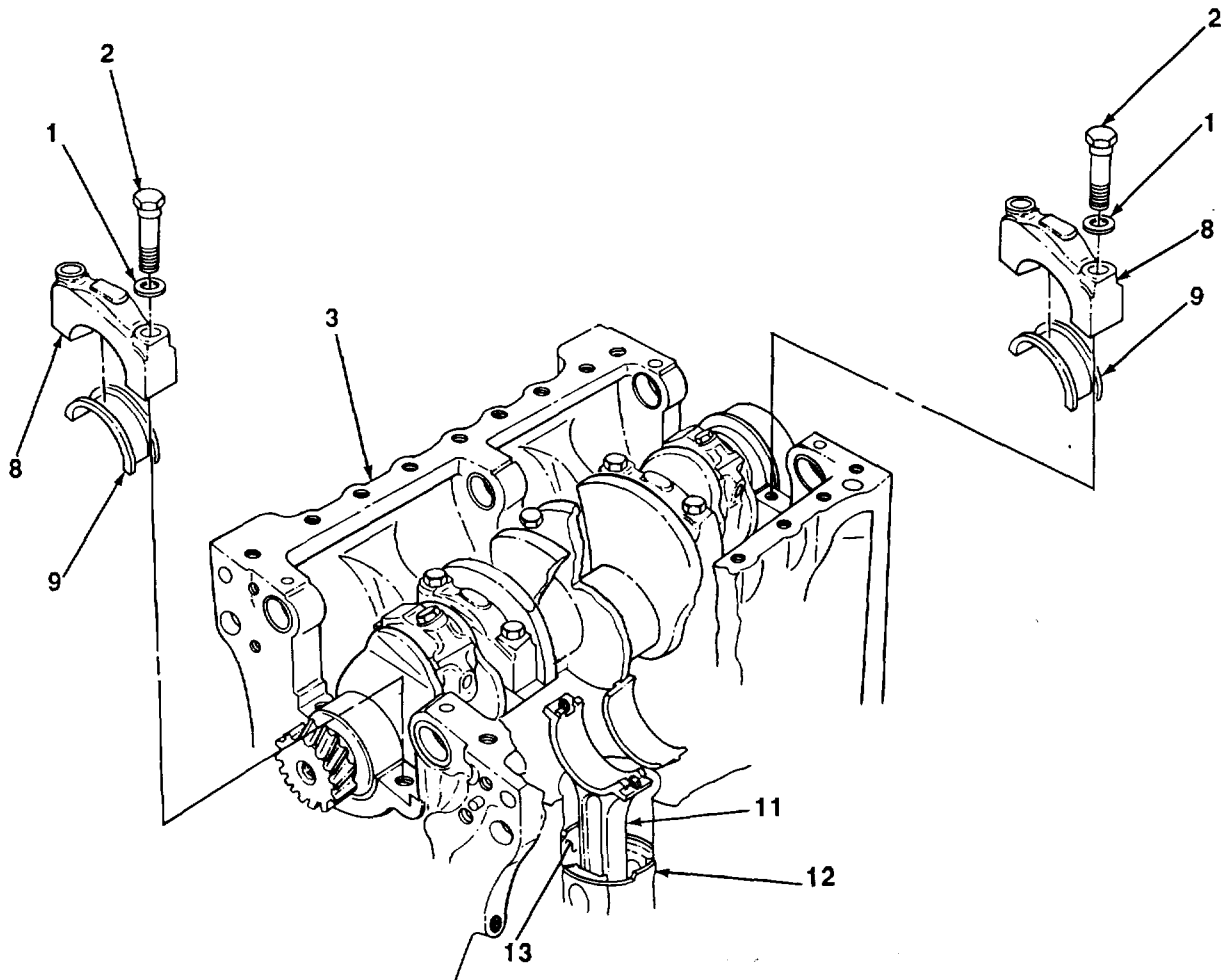

TA701252

3-8. CRANKSHAFT MAINTENANCE (Con't).

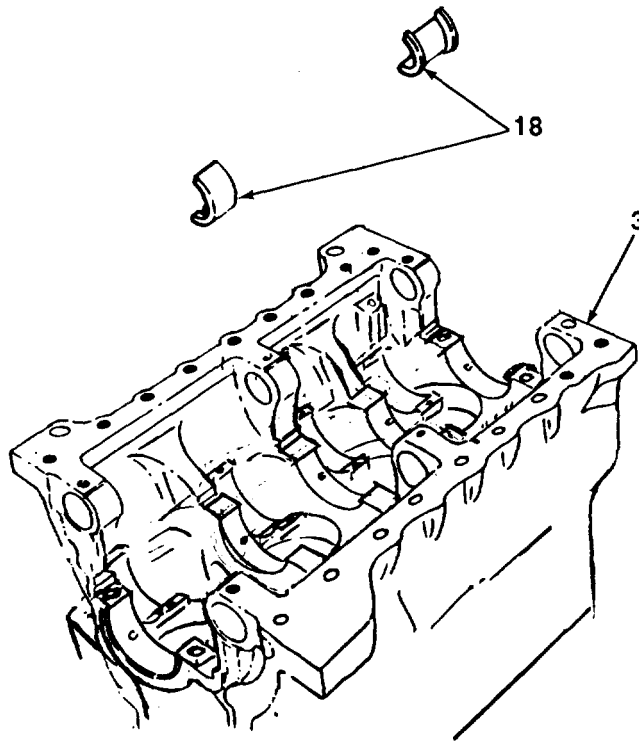
**NOTE**

If one main bearing is replaced, all main bearings must be replaced.

16. If clearance is not within specification and mating main bearing journal is within specification, replace main bearings. Refer to Table 3-1 to determine what size bearings should be used.
17. Remove two screws (2), washers (1), and main bearing cap (8) with attached lower sleeve bearing half (9) from engine block (3). Remove lower sleeve bearing half from main bearing cap.
18. Remove upper sleeve bearing half (18) from engine block (3).
19. If end play measurement taken in step 1 of removal is not within specification, replace upper and lower sleeve bearing halves (9 and 18) in accordance with Table 3-1.

NOTE

Measurement of inside diameter of one connecting rod bearing is described in steps 20 through 29. Repeat steps for other connecting rod bearings.

20. Pull connecting rod (11) and assembled piston (12) up in cylinder sleeve (13) until accessible.

TA701253

3-8. CRANKSHAFT MAINTENANCE (Con't).

Table 3-1. Main Bearing and Journal Dimensions.

Bearing Size In Inches (mm)	Connecting Rod Journal Diameter In Inches (mm)	Main Bearing Journal Diameter In Inches (mm)
Standard	2.7480-2.7490 (69.7792-69.8246)	3.1230-3.1240 (79.3242-79.3496)
0.002 (0.0508) Undersize	2.7480-2.7490 (69.7992-69.8246)	3.1230-3.1240 (79.3242-79.3496)
0.010 (0.254) Undersize	2.7470-2.7480 (69.7738-69.7992)	3.1220-3.1230 (79.2988-79.3242)
0.020 (0.508) Undersize	2.7460-2.7470 (69.7484-69.7738)	3.1210-3.1220 (79.2734-79.2988)
0.030 (0.762) Undersize	2.7450-2.7460 (69.7230-69.7484)	3.1200-3.1210 (79.2480-79.2734)

CAUTION

Ensure that connecting rod bearing cap is installed on same connecting rod from which it was removed. Failure to do this may cause incorrect inside diameter measurement and damage to parts.

21. Slide upper sleeve bearing half (10) into position on connecting rod (11). Ensure that tang on upper sleeve bearing half fits in locking groove in connecting rod.
22. Slide lower sleeve bearing half (4) into position in connecting rod bearing cap (5). Ensure that stampings line up as noted during removal.
23. Position connecting rod bearing cap (5) and assembled lower sleeve bearing half (4) in place on connecting rod (11).
24. Coat threads of two bolts (7) with engine oil. Install two bolts and washers (6) in connecting rod bearing cap (5) and connecting rod (11). Torque bolts to 65 lb.-ft. (88 N.m).
25. Using rod measuring kit, measure inside diameter of upper and lower sleeve bearing halves (10 and 4). Diameter must be 2.7502-2.7522 in. (69.8551-69.9059 mm).
26. Subtract largest measurement for connecting rod bearing journal taken in step 7 from measurement taken in step 25. Difference is clearance.

NOTE

If one connecting rod bearing is replaced, all connecting rod bearings must be replaced.

27. Clearance must be 0.0012-0.0062 in. (0.0305-0.1575 mm). If clearance is not within specification and mating Journal is within specification, replace upper and lower sleeve bearing halves (10 and 4) in accordance with Table 3-1.

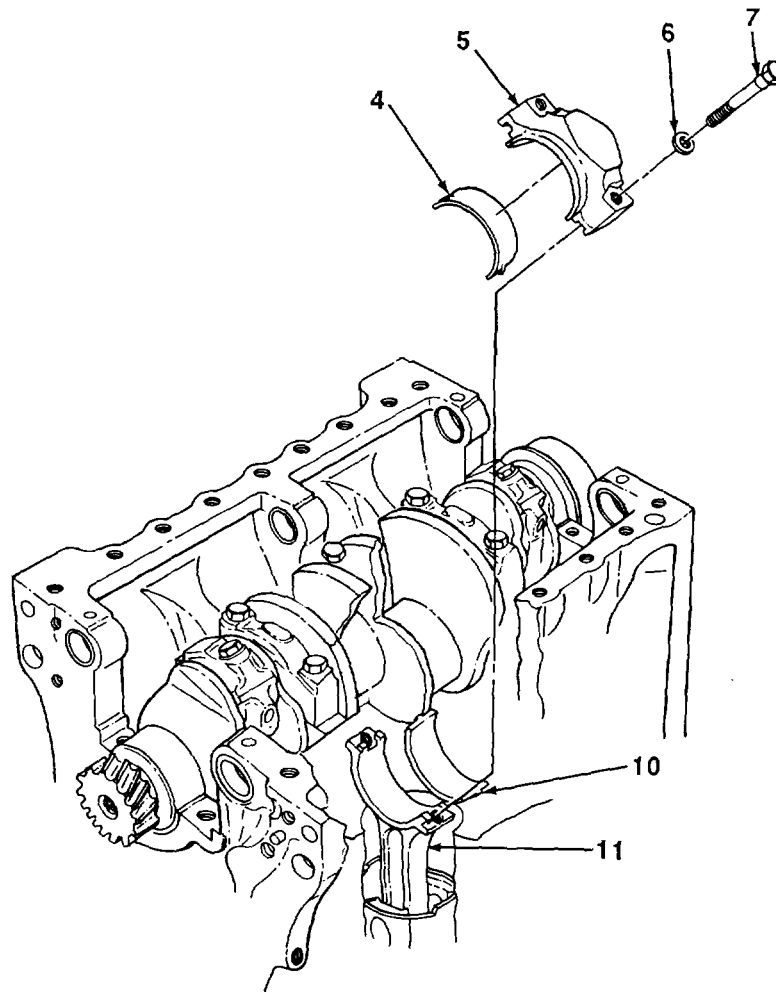
3-8. CRANKSHAFT MAINTENANCE (Con't).

28. Remove two bolts (7), washers (6), connecting rod bearing cap (5), and assembled lower sleeve bearing half (4) from connecting rod (11). Slide lower sleeve bearing half out of connecting rod bearing cap.
29. Slide upper sleeve bearing half (10) out of connecting rod (11).
30. Inspect crankshaft for damaged threads and spur gear for burrs and worn gear teeth. Replace if damaged.
31. Inspect all other metal parts for cracks, bends, and breaks. Replace if damaged.

TA701254

3-8. CRANKSHAFT MAINTENANCE (Con't).

d. ASSEMBLY

1. Tap woodruff key (19) in place in crankshaft (14).

WARNING

Hot oil gives off highly flammable fumes. When heating parts in oil, do not smoke or allow open flame nearby. Ensure that area is well-ventilated. Heat parts only in tank with lid which can be quickly closed to extinguish fire. Wear eye protection, protective gloves and clothing when heating parts in oil and handling hot parts. Hot oil and hot parts can cause severe burns.

2. Heat spur gear (16) for 30 minutes in engine oil at 300°F (1490C).
3. Remove spur gear (16) from hot oil and tap in position on crankshaft (14) and woodruff key (19).
4. If straight pin (17) was removed, install in crankshaft (14) using stud remover and setter.

e. INSTALLATION

1. Slide five upper sleeve bearing halves (18) into position on engine block (3). Ensure that tangs on upper sleeve bearing halves fit in locking grooves in engine block and oil holes in upper sleeve bearing halves line up with oil passages in engine block.
2. Coat upper sleeve bearing halves (18) with engine oil.

CAUTION

When installing crankshaft in engine block, use care not to knock crankshaft against engine block. Knocking crankshaft may damage parts.

3. Coat all crankshaft journals with engine oil. With the aid of an assistant, position crankshaft (14) in place on engine block (3).

3-8. CRANKSHAFT MAINTENANCE (Con't).

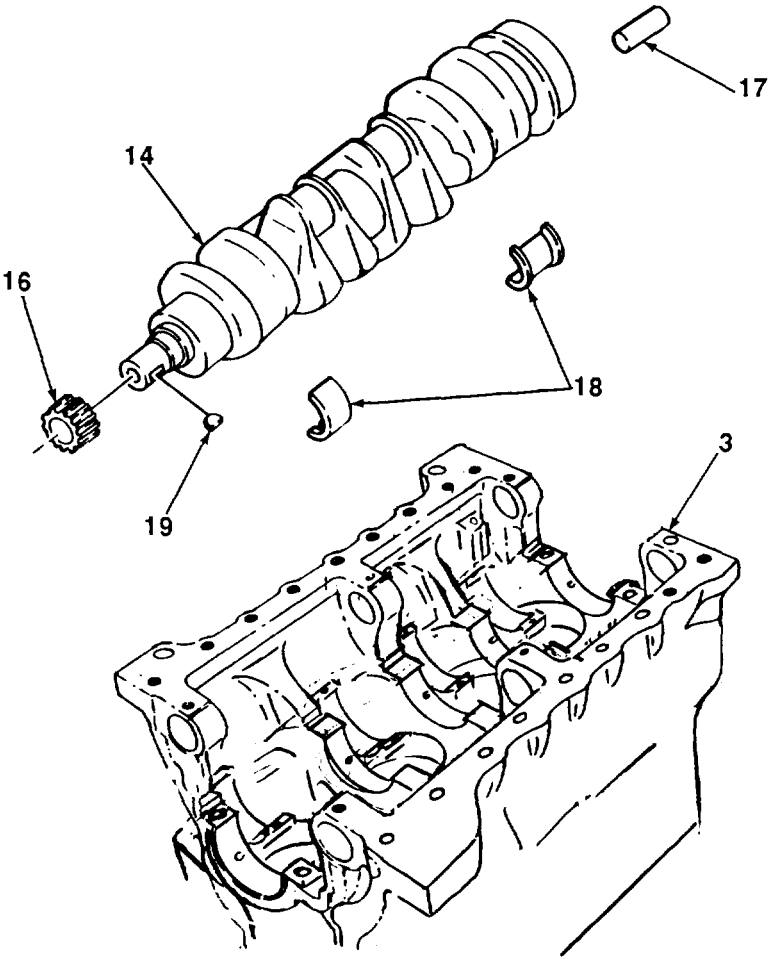

TA701255

3-8. CRANKSHAFT MAINTENANCE (Con't).

CAUTION

Lower sleeve bearing halves must be installed in same bearing caps from which they were removed. Failure to do so may damage parts.

NOTE

Engine has five main bearing caps. Installation of all five is the same. One is shown. Repeat steps 4 through 6 for remaining main bearing caps.

- 4. Slide lower sleeve bearing half (9) in place in main bearing cap (8). Ensure that tangs on lower sleeve bearing half fit in locking groove of main bearing cap and oil holes line up with oil passages. Coat parts with engine oil.
- 5. Position main bearing cap (8) and assembled lower sleeve bearing half (9) in place on engine block (3) and crankshaft (14) with match-marks aligned.
- 6. Coat threads of two screws (2) with engine oil. Install two screws and washers (1) in main bearing cap (8) and engine block (3).

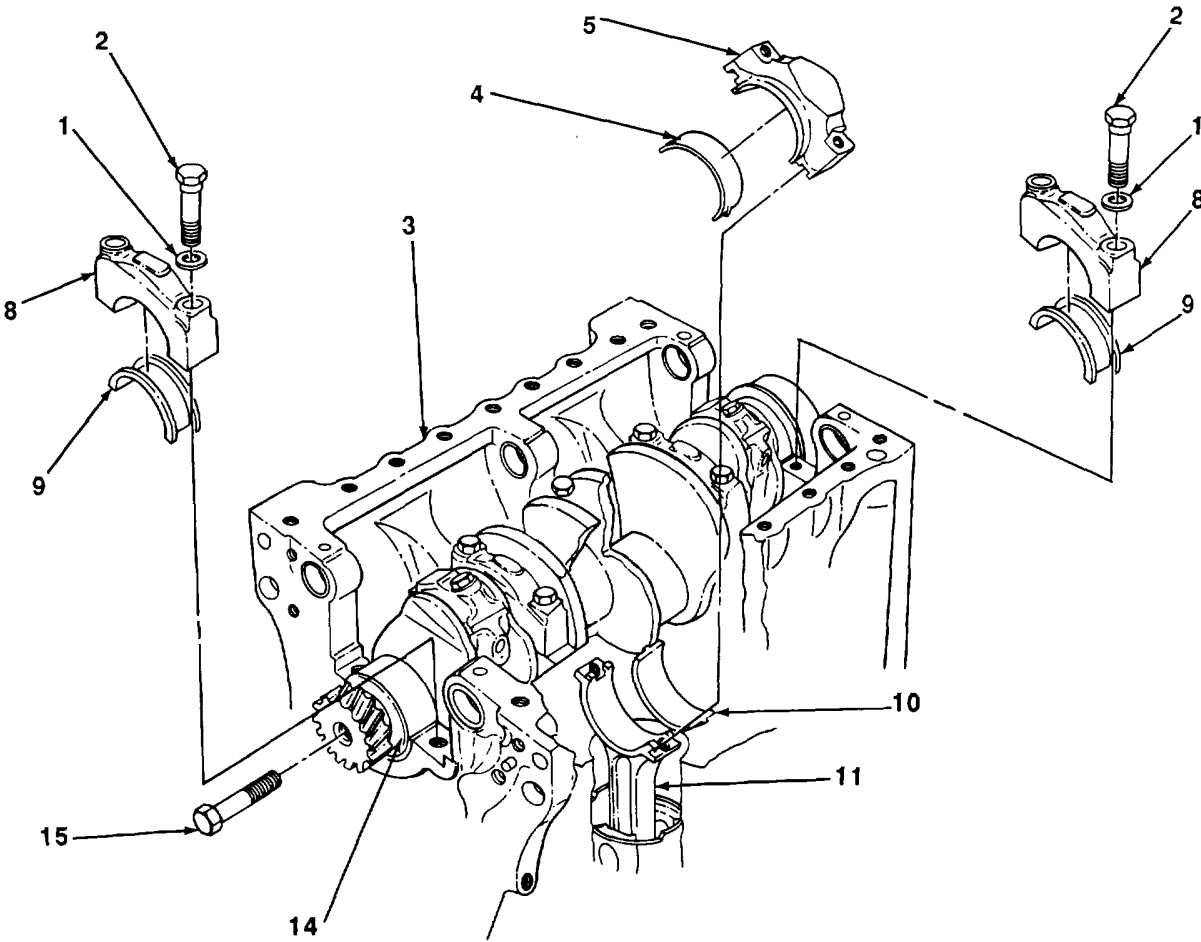

3-8. CRANKSHAFT MAINTENANCE (Con't).

7. Using ball-peen hammer and wood block, tap crankshaft (14) to the rear of engine block (3). Aline front flanges of upper and lower sleeve bearing halves (9 and 18).
8. Using ball-peen hammer and wood block, tap crankshaft (14) to the front of engine block (3). Aline rear flanges of upper and lower sleeve bearing halves (9 and 18).

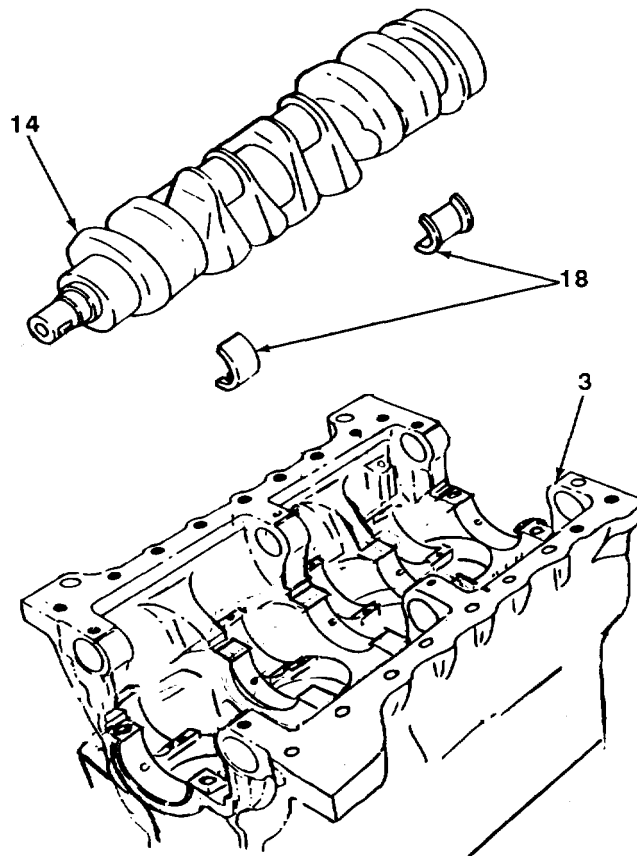

9. Torque screws (2) to 85 lb.-ft. (115 N•m).

NOTE

Engine has four connecting rod bearing caps. Installation of all four is the same. One is shown. Repeat steps 10 through 15 for remaining connecting rod bearing caps.

10. Install screw (15) in end of crankshaft (14). Using screw, rotate crankshaft until mating journal of desired connecting rod bearing cap (5) is accessible.
11. Slide upper sleeve bearing half (10) in place on connecting rod (11). Ensure that tang on upper sleeve bearing half in locking groove of connecting rod. Coat parts with engine oil.
12. Pull connecting rod (11) with assembled parts down into position on crankshaft (14).
13. Slide lower sleeve bearing half (4) in place in connecting rod bearing cap (5). Ensure that tang on lower sleeve bearing half fits in locking groove of connecting rod bearing cap. Coat parts with engine oil.

TA701257

3-8. CRANKSHAFT MAINTENANCE (Con't).

14. Position connecting rod bearing cap (5) and assembled lower sleeve bearing half (4) in place on connecting rod (11) and crankshaft (14).
15. Coat threads of two bolts (7) with engine oil. Install two bolts and washers (6) in connecting rod bearing cap (5) and connecting rod (11). Torque bolts to 65 lb.-ft. (88 N•m).
16. Remove screw (15) from end of crankshaft (14).

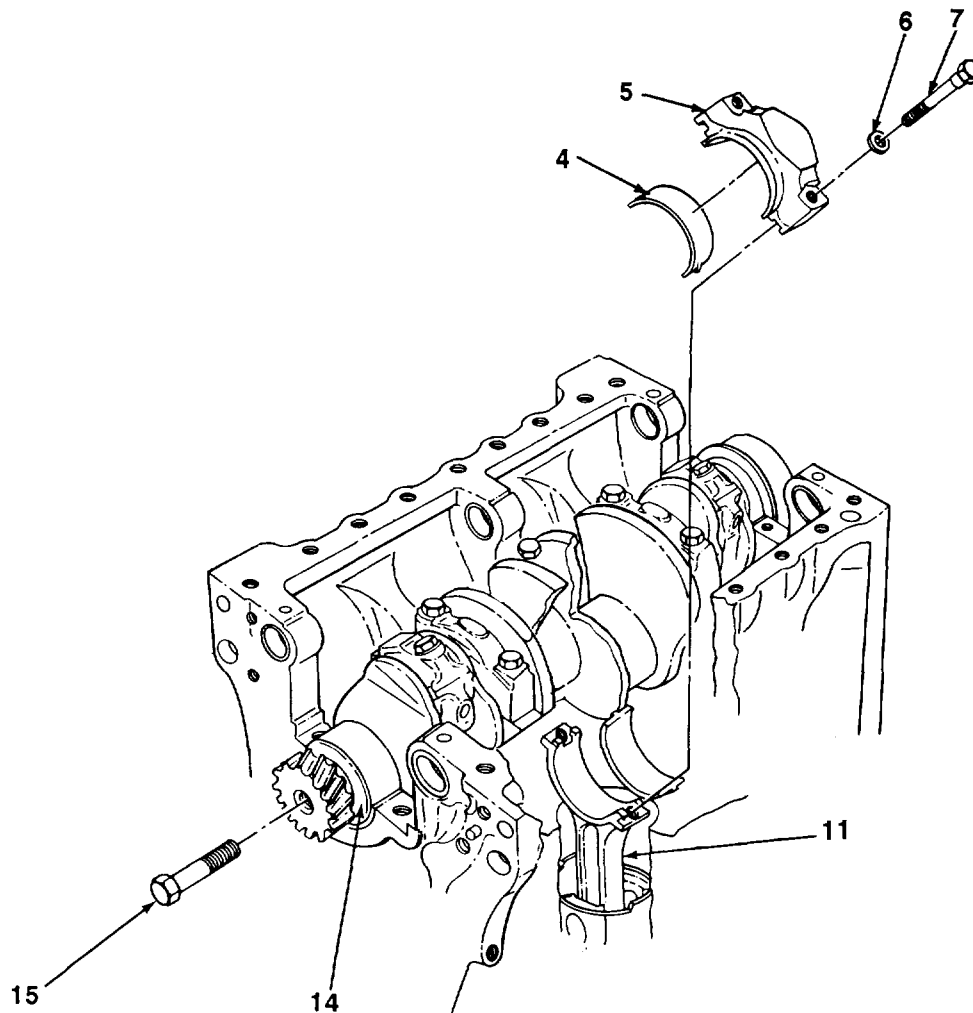

FOLLOW-ON TASKS:

- Install cylinder block plate (see paragraph 3-7).
- Install fuel injection nozzles (see TM 5-2420-222-20).
- Install flywheel housing (see paragraph 3-10).
- Install engine oil pan (see paragraph 3-20).
- Install engine assembly (see paragraph 3-3).

3-9. ENGINE FLYWHEEL AND RING GEAR MAINTENANCE.

This Task Covers:

- | | |
|----------------------------|-----------------|
| a. Removal | d. Assembly |
| b. Cleaning and Inspection | e. Installation |
| c. Disassembly | |

Initial Setup:

Equipment Conditions:

- Clutch pressure plate, disk, carrier, and bearing removed (see paragraph 4-1 or 4-2).

Materials/Parts:

- Rags (Item 28, Appendix B)
- Dry cleaning solvent (Item 31, Appendix B)

Tools/Test Equipment:

- General mechanic's tool kit
- Field automotive shop set

Personnel Required: Two

General Safety Instructions:

- Dry cleaning solvent is flammable and must not be used near open flame. Use only in a well-ventilated area.

References:

- TM 9-214
-

3-9. ENGINE FLYWHEEL AND RING GEAR MAINTENANCE (Con't).**a. REMOVAL****WARNING**

Use extreme caution when handling heavy parts. Lifting device is required when parts weigh over 50 lb (23 kg) for a single person lift, over 100 lb (45 kg) for a two person lift, and over 150 lb (68 kg) for a three or more person lift. Keep clear of heavy parts supported only by lifting device. Failure to follow this warning may cause serious injury or death to personnel.

1. Attach and support flywheel (4) and assembled ring gear (3) with lifting device.
2. Remove four capscrews (6) from flywheel (4) and crankshaft (1).
3. Using lifting device and the aid of an assistant, lift flywheel (4) and assembled ring gear (3) off crankshaft (1) and pin (2).
4. Set flywheel (4) and assembled ring gear (3) on flat surface and remove lifting device.

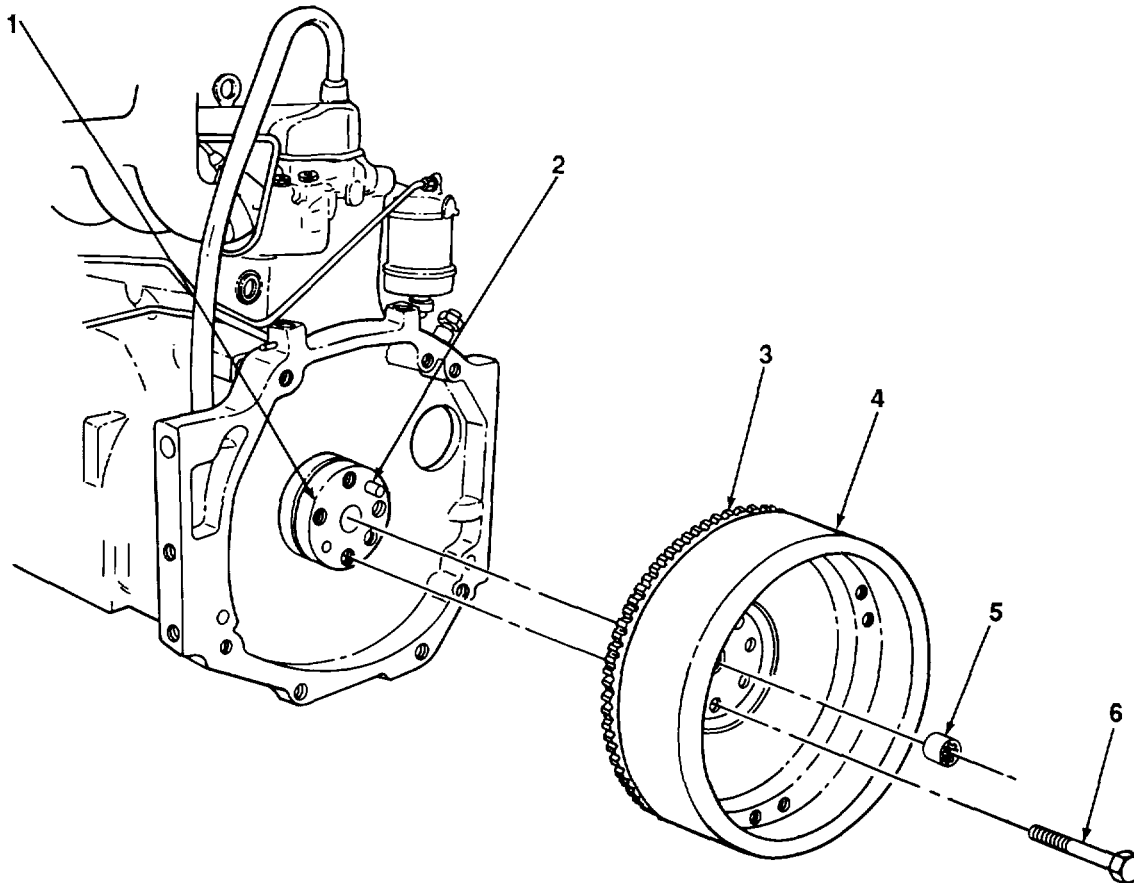

TA701259

3-9. ENGINE FLYWHEEL AND RING GEAR MAINTENANCE (Con't).

b. CLEANING AND INSPECTION

WARNING

Dry cleaning solvent, P-D-680, is toxic and flammable. Always wear protective goggles and gloves, and use only in a well-ventilated area. Avoid contact with skin, eyes, and clothes, and DO NOT breathe vapors. DO NOT use near open flame or excessive heat. The solvent's flash point is 100°F-138°F (38°C-59°C). If you become dizzy while using cleaning solvent, immediately get fresh air and medical help. If solvent contacts eyes, immediately wash your eyes and get medical aid.

1. Clean flywheel and assembled ring gear and four capscrews with dry cleaning solvent and rags. Dry parts thoroughly with clean, dry rags.
2. Inspect flywheel and assembled ring gear for cracks, breaks, damaged teeth, scoring, and discoloration. If damaged, replace flywheel and assembled ring gear.
3. Using square edge and thickness gage, measure flatness of clutch contact surface at several locations on flywheel. Clutch contact surface must be flat within 0.006 in. (0.152 mm).
4. Inspect ball bearing (5) (see TM 9-214).

c. DISASSEMBLY

CAUTION

Do not perform disassembly unless ball bearing is damaged. Damage to parts may result.

Using mechanical gear and bearing puller, remove ball bearing (5) from flywheel (4) and assembled ring gear (3).

d. ASSEMBLY

If removed, install ball bearing (5) on flywheel (4) and assembled ring gear (3) with hammer and drift.

e. INSTALLATION

WARNING

Use extreme caution when handling heavy parts. Lifting device is required when parts weigh over 50 lb (23 kg) for a single person lift, over 100 lb (45 kg) for a two person lift, and over 150 lb (68 kg) for a three or more person lift. Keep clear of heavy parts supported only by lifting device. Failure to follow this warning may cause serious injury or death to personnel.

1. With the aid of an assistant and lifting device, lift flywheel (4) and assembled ring gear (3) into position on crankshaft (1) and pin (2).
2. Install four capscrews (6) in flywheel (4) and crankshaft (1). Torque capscrews to 120 lb.-ft. (163 N•m).
3. Remove lifting device from flywheel (4) and assembled ring gear (3).

FOLLOW-ON TASKS:

- Install clutch pressure plate, disk, carrier, and bearing (see paragraph 4-1 or 4-2).

3-10. FLYWHEEL HOUSING MAINTENANCE.*This Task Covers:*

- | | |
|----------------------------|-----------------|
| a. Removal | d. Assembly |
| b. Disassembly | e. Installation |
| c. Cleaning and Inspection | |

*Initial Setup:***Equipment Conditions:**

- Engine assembly removed (see paragraph 3-3).
- Clutch pressure plate, disk, carrier, and bearing removed (see paragraph 4-1 or 4-2).
- Engine oil pressure switch removed (see TM 5-2420-).
- Engine flywheel and ring gear removed (see paragraph 3-9).

Materials/Parts:

- Rags (Item 28, Appendix B)
- Dry cleaning solvent (Item 31, Appendix B)
- One gasket
- One seal

Personnel Required: Two**Tools/Test Equipment:**

- General mechanic's tool kit
- Field automotive shop set
- Driver
- Pilot

General Safety Instructions:

- Dry cleaning solvent is flammable and must not be used near open flame. Use only in a well-ventilated area.

a. REMOVAL

1. With assistant holding flywheel housing (2) in place, remove nine screws (1) from flywheel housing and engine block (5).

WARNING

Use extreme caution when handling heavy parts. Lifting device is required when parts weigh over 50 lb (23 kg) for a single person lift, over 100 lb (45 kg) for a two person lift, and over 150 lb (68 kg) for a three or more person lift. Keep clear of heavy parts supported only by lifting device. Failure to follow this warning may cause serious injury or death to personnel.

2. With the aid of an assistant, pry and lift flywheel housing (2) free of engine block (5) and set on wood blocks.
3. Remove gasket (4) from mating surfaces of flywheel housing (2) and engine block (5). Discard gasket.
4. Using ball-peen hammer and punch, tap out seal (3) from flywheel housing (2). Discard seal.

3-10. FLYWHEEL HOUSING MAINTENANCE (Con't).

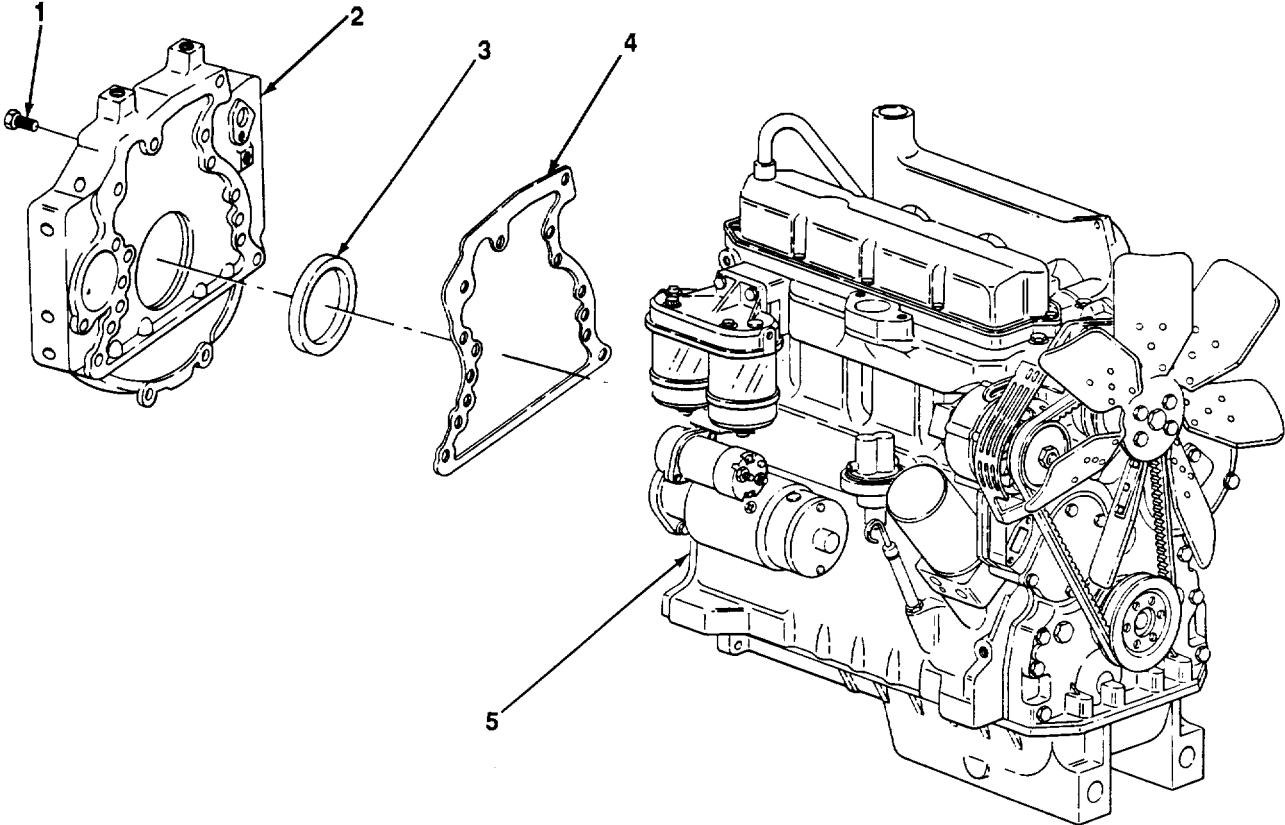

TA701260

3-10. FLYWHEEL HOUSING MAINTENANCE (Con't).

b. DISASSEMBLY

1. Remove headless shoulder pin (8) and timing hole cover (7) from flywheel housing (2).

CAUTION

Do not remove plug and pins unless damaged. Removal may damage parts.

2. Using ball-peen hammer and punch, drive plug (9) out of flywheel housing (2).
3. Using plier wrench, remove two pins (6) from flywheel housing (2).

c. CLEANING AND INSPECTION**WARNING**

Dry cleaning solvent, P-D-680, is toxic and flammable. Always wear protective goggles and gloves, and use only in a well-ventilated area. Avoid contact with skin, eyes, and clothes, and DO NOT breathe vapors. DO NOT use near open flame or excessive heat. The solvent's flash point is 100°F-138°F (38°C-59°C). If you become dizzy while using cleaning solvent, immediately get fresh air and medical help. If solvent contacts eyes, immediately wash your eyes and get medical aid.

1. Using putty knife and dry cleaning solvent, remove gasket material from mounting surface of flywheel housing and engine block.
2. Clean all metal parts with dry cleaning solvent, then dry thoroughly with clean rags.
3. Inspect flywheel housing, timing hole cover, and pins for cracks, bends, and breaks. Replace defective parts.
4. Inspect threaded parts for damaged threads. Restore damaged threads using screw threading set.

d. ASSEMBLY

1. If removed, position two pins (6) and plug (9) in place in flywheel housing (2). Tap pins and plug in flywheel housing until seated.
2. Position timing hole cover (7) in place on flywheel housing (2) and install headless shoulder pin (8).

3-10. FLYWHEEL HOUSING MAINTENANCE (Con't).

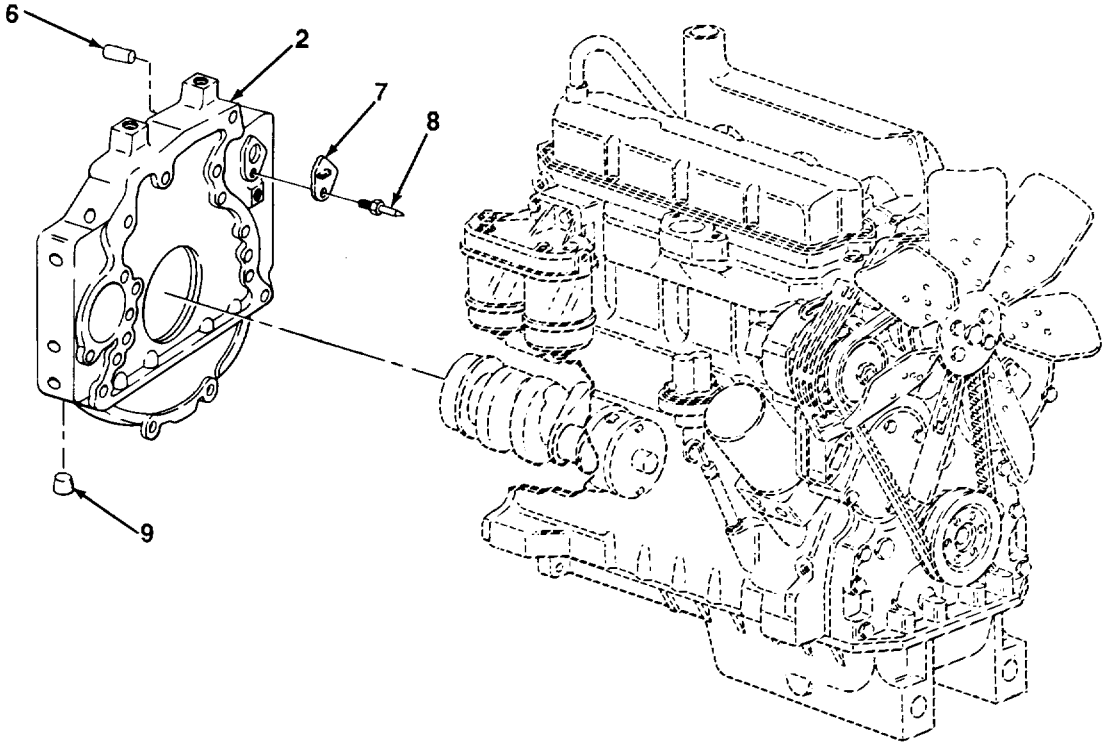

TA701261

3-10. FLYWHEEL HOUSING MAINTENANCE (Con't).**e. INSTALLATION**

1. Using pilot and driver, install new seal (3) in flywheel housing (2).
2. Position new gasket (4) in place on engine block (5).

WARNING

Use extreme caution when handling heavy parts. Lifting device is required when parts weigh over 50 lb (23 kg) for a single person lift, over 100 lb (45 kg) for a two person lift, and over 150 lb (68 kg) for a three or more person lift. Keep clear of heavy parts supported only by lifting device. Failure to follow this warning may cause serious injury or death to personnel.

3. With the aid of an assistant, lift flywheel housing (2) into position on engine block (5).
4. Install nine screws (1) in flywheel housing (2) and engine block (5).

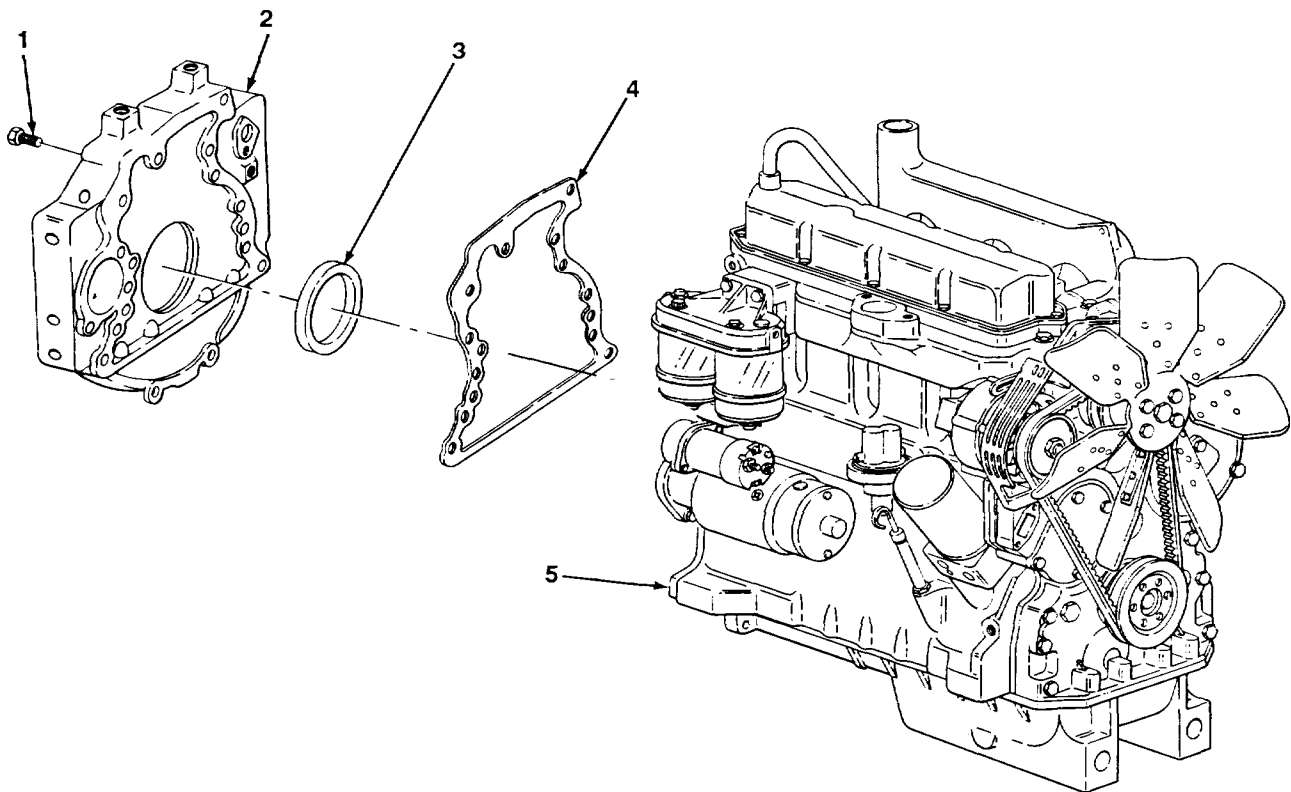
**FOLLOW-ON TASKS:**

- Install engine flywheel and ring gear (see paragraph 3-9).
- Install engine oil pressure switch (see TM 5-2420-222-20).
- Install clutch pressure plate, disk, carrier, and bearing (see paragraph 4-1 or 4-2).
- Install engine assembly (see paragraph 3-3).

TA701262

3-11. PISTON, CONNECTING ROD, AND CONNECTING ROD BEARING MAINTENANCE.

This Task Covers:

- | | | |
|----------------------------|----|-----------------|
| a. Removal | d. | Assembly |
| b. Disassembly | | e. Installation |
| c. Cleaning and Inspection | | |
-

Initial Setup:

Equipment Conditions:

- Engine assembly removed (see paragraph 3-3).
- Cylinder head removed (see paragraph 3-6).
- Engine oil pan removed (see paragraph 3-20).

Tools/Test Equipment:

- General mechanic's tool kit
- Field automotive shop set
- Ring groove wear gage

Personnel Required: Two

General Safety Instructions:

- Dry cleaning solvent is flammable and must not be used near open flame. Use only in a well-ventilated area.
- Compressed air used for cleaning purposes should never exceed 30 psi (207 kPa).

Materials/Parts:

- Abrasive cloth (Item 6, Appendix B)
- Carbon removing compound (Item 8, Appendix B)
- Engine oil (Item 25, Appendix B)
- Rags (Item 28, Appendix B)

- Dry cleaning solvent (Item 31, Appendix B)
- Marker tags (Item 32, Appendix B)
- Nonelectrical wire (Item 44, Appendix B)
- Piston ring set
- Two screws, ½ X ¾ in. long
- Two washers

NOTE

All four pistons and connecting rods are maintained the same way. One is shown. Repeat procedure for other pistons and connecting rods.

3-11. PISTON, CONNECTING ROD, AND CONNECTING ROD BEARING MAINTENANCE (Con't).

a. REMOVAL

- Using cylinder ridge reamer, remove carbon ridge from cylinder sleeve (1).

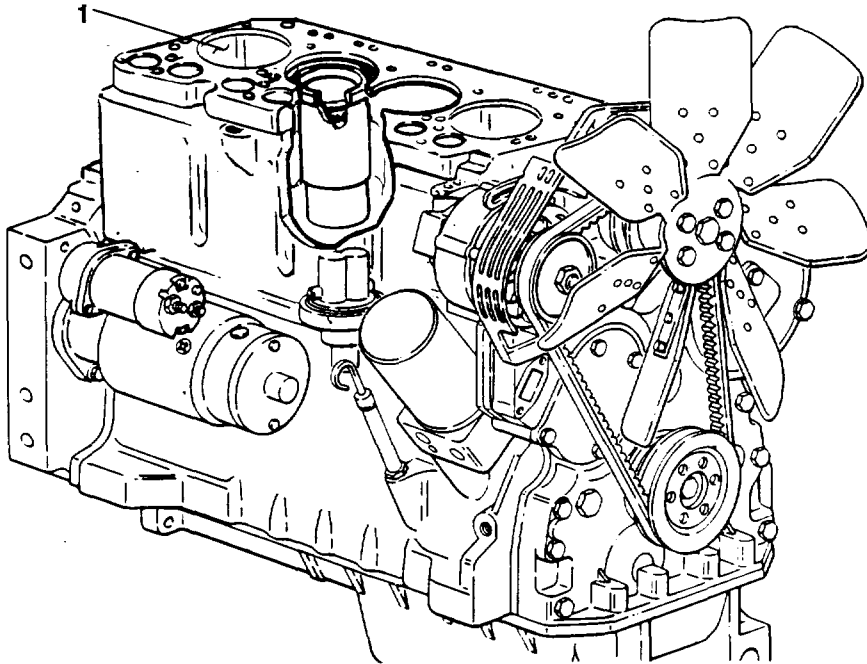

- Using screw (19), turn crankshaft pulley (18) until desired piston is at bottom of its stroke.

CAUTION

When removing connecting rod bearing cap, ensure that lower sleeve bearing half does not fall out of connecting rod bearing cap. If lower sleeve bearing half falls out, it may damage parts.

- Remove two bolts (6), washers (7), and connecting rod bearing cap (5) with assembled lower sleeve bearing half (4) from connecting rod (9).

CAUTION

Pistons and connecting rods must be installed in same location from which they are removed. Failure to do so may damage parts.

- With the aid of an assistant, tap on bottom of piston (11) and connecting rod (9) until it can be removed from top of engine block (2).

b. DISASSEMBLY

- Slide lower sleeve bearing half (4) out of connecting rod bearing cap (5).

TA701263

3-11. PISTON, CONNECTING ROD, AND CONNECTING ROD BEARING MAINTENANCE (Con't).

2. Slide upper sleeve bearing half (8) out of connecting rod (9).

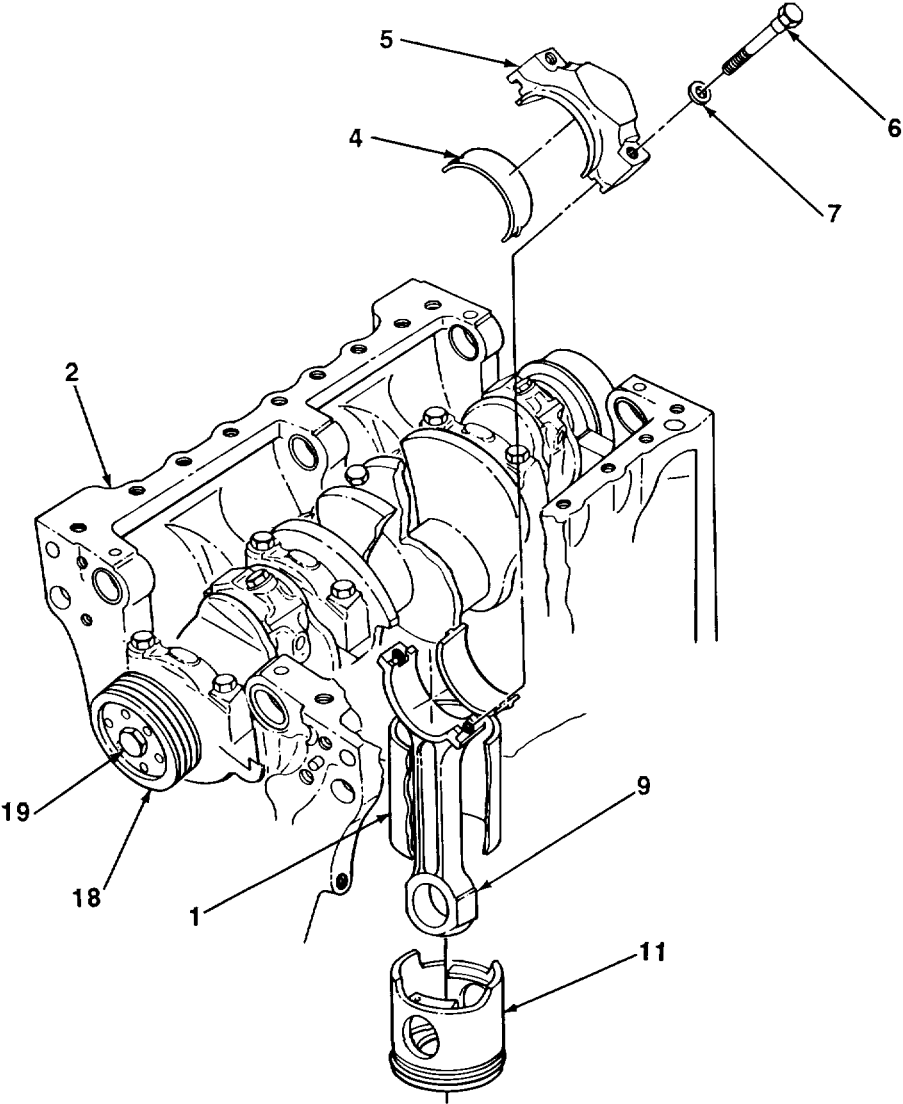

3-11. PISTON, CONNECTING ROD, AND CONNECTING ROD BEARING MAINTENANCE (Con't).

NOTE

If one piston ring must be replaced, replace all three piston rings and oil ring expander.

3. Using piston ring expander, remove two compression rings (14 and 15), oil ring (13), and oil ring expander (12) from piston (11). Discard rings.
4. Using retaining ring pliers, remove two retaining rings (10) from piston (11) and piston pin (16).
5. Push piston pin (16) out of piston (11) and sleeve bushing (17). Remove piston from connecting rod (9) and sleeve bushing.

CAUTION

Do not remove sleeve bushing unless damaged, Removal may damage parts.

6. Using remover and installer and arbor press, remove sleeve bushing (17) from connecting rod (9).

c. CLEANING AND INSPECTION

WARNING

Carbon removing compound is a corrosive liquid. If splashed in eyes, it can cause blindness. If splashed on skin, it can cause serious burns. Be sure to wear safety goggles or lenses, rubber apron, and rubber gloves. If accidentally splashed in eyes or on skin, flush with clean cool water, refer to FM 21-11 for first aid information, and get medical attention immediately.

1. Soak piston in carbon removing compound. Using flexible carbon scraper, scrape piston head clean, then rinse with water.
2. Using piston ring groove reconditioning tool, clean piston ring grooves.

WARNING

Dry cleaning solvent, P-D-680, is toxic and flammable. Always wear protective goggles and gloves, and use only in a well-ventilated area. Avoid contact with skin, eyes, and clothes, and DO NOT breathe vapors. DO NOT use near open flame or excessive heat. The solvent's flash point is 100°F-138°F (38°C-59°C). If you become dizzy while using cleaning solvent, immediately get fresh air and medical help. If solvent contacts eyes, immediately wash your eyes and get medical aid.

3. Using nonelectrical wire, clean oil holes and flush clean with dry cleaning solvent. Dry thoroughly with clean
4. Clean connecting rod, piston pin, and sleeve bushing with dry cleaning solvent, then dry thoroughly with a clean
5. Inspect upper and lower sleeve bearing halves (8 and 4) for cracks, grooves, rough spots, and breaks. Remove rough spots and minor scratches with abrasive cloth.
6. Inspect piston for cracks, scoring, or excessive wear or scorching. Pistons badly scored below top ring groove must be replaced.
7. Using ring groove wear gage, measure top ring groove. If gage shoulders touch ring land, groove is excessively worn.

3-11. PISTON, CONNECTING ROD, AND CONNECTING ROD BEARING MAINTENANCE (Con't).

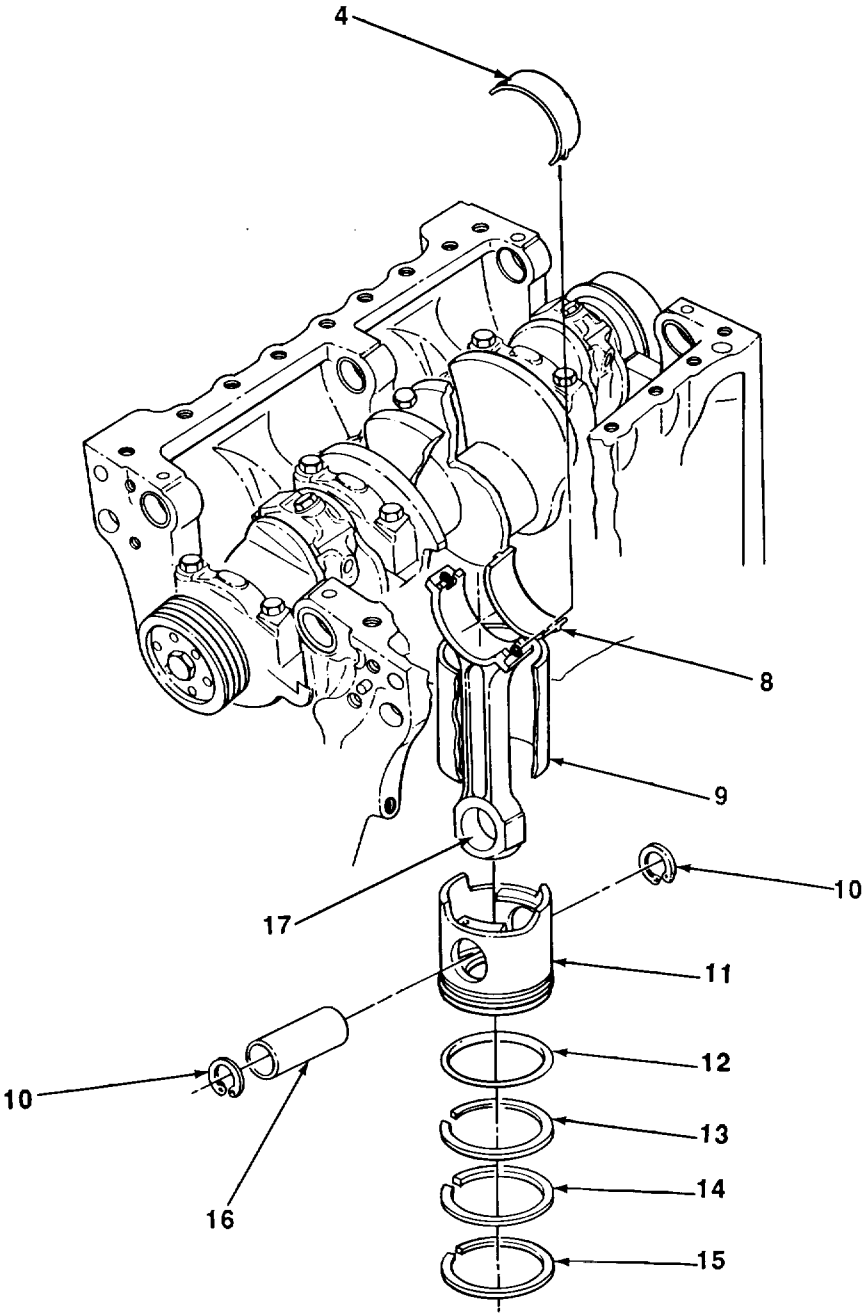

TA701265

3-11. PISTON, CONNECTING ROD, AND CONNECTING ROD BEARING MAINTENANCE (Con't).

NOTE

Piston compression rings and oil ring come as a set of three. Oil ring is made up of two parts; an oil ring and an oil ring expander.

8. Using piston ring expander, install two new compression rings (14 and 15), new oil ring (13), and new oil ring expander (12).
9. Using thickness gage, measure ring clearance. Clearance must not exceed 0.008 in. (0.203 mm).
10. Using piston ring expander, remove two compression rings (14 and 15), oil ring (13), and oil ring expander (12) from piston.
11. Inspect sleeve bushing (17) for cracks, breaks, and excessive wear. Using rod measuring kit, measure inside diameter. Inside diameter must be 1.3760-1.3800 in. (34.9504-35.0520 mm).
12. Inspect piston pin (16) for cracks, bends, or breaks. Using micrometer caliper set, measure outside diameter. Outside diameter must be 1.3748-1.3752 in. (34.9199-34.9301 mm).
13. Subtract measurement taken in step 12 from measurement taken in step 11. The difference is oil clearance. Clearance must be 0.0008-0.0042 in. (0.0203-0.1067 mm).
14. Inspect connecting rod (9) for cracks, breaks, and damaged threads. Restore damaged threads with screw threading set.
15. Place connecting rod (9) in vise with caps. Position connecting rod bearing cap (5) on connecting rod. Coat threads of two bolts (6) with engine oil. Install bolts and washers (7) in connecting rod bearing cap and connecting rod. Torque bolts to 65 lb.-ft. (88 N•m).
16. Using rod measuring kit, measure bore diameter of connecting rod (9) and connecting rod bearing cap (5). Diameter must be 2.9000-2.9010 in. (73.6600-73.6854 mm).
17. Remove two bolts (6) and washers (7) from connecting rod bearing cap (5) and connecting rod (9). Remove connecting rod bearing cap from connecting rod.
18. Slide upper sleeve bearing half (8) in place on connecting rod (9). Ensure that tang on upper sleeve bearing half fits in locking groove of connecting rod.
19. Slide lower sleeve bearing half (4) in place in connecting rod bearing cap (5). Ensure that tang on lower sleeve bearing half fits in locking groove of connecting rod bearing cap.
20. Position connecting rod bearing cap (5) and assembled lower sleeve bearing half (4) in place on connecting rod (9) and assembled upper sleeve bearing half (8).
21. Coat threads of two bolts (6) with engine oil. Install bolts and washers (7) in connecting rod bearing cap (5) and connecting rod (9). Torque bolts to 65 lb.-ft. (88 N•m).
22. Using rod measuring kit, measure bore diameter of upper and lower sleeve bearing halves (8 and 4). Diameter must be 2.7502-2.7522 in. (69.8551-69.9059 mm).
23. Remove two bolts (6) and washer (7) and connecting rod bearing cap (5) with assembled lower sleeve bearing half (4) from connecting rod (9) and assembled upper sleeve bearing half (8).
24. Remove upper and lower sleeve bearing halves (8 and 4) from connecting rod (9) and connecting rod bearing cap (5).

3-11. PISTON, CONNECTING ROD, AND CONNECTING ROD BEARING MAINTENANCE (Con't).

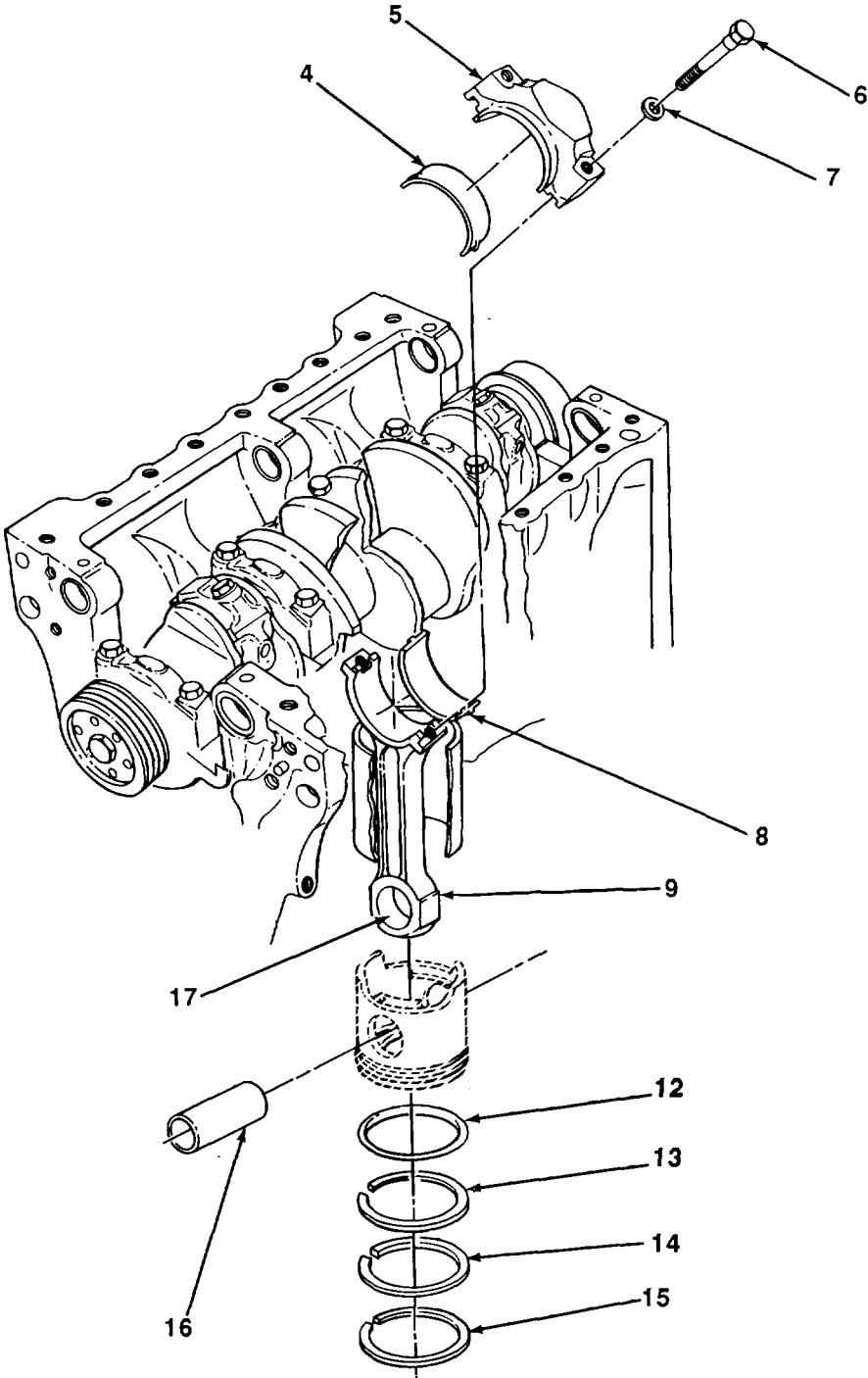

3-11. PISTON, CONNECTING ROD, AND CONNECTING ROD BEARING MAINTENANCE (Con't).

d. ASSEMBLY**NOTE**

Perform steps 1 and 2 only if sleeve bushing was removed.

1. Using arbor press and remover and installer, press sleeve bushing (17) in connecting rod (9). Ensure that oil holes line up. If sleeve bushing is new, ensure that 1 11/32 - 1 17/32 in. hand reamer can be pushed in sleeve bushing by hand.

WARNING

Compressed air used for cleaning or drying purposes, or for clearing restrictions, should never exceed 30 psi (207 kPa). Wear protective clothing (goggles/shield, gloves, etc.) and use caution to avoid injury to personnel.

2. Remove any metal particles left by reaming with compressed air.
3. Position piston (11) in place on connecting rod (9). Coat piston pin (16) with engine oil. Install piston pin in piston and sleeve bushing (17).
4. Using retaining ring pliers, install two retaining rings (10) on ends of piston pin (16).

NOTE

Piston compression rings and oil ring come as a set of three. Oil ring is made up of two parts; an oil ring and an oil ring expander.

5. Lubricate oil ring expander (12), oil ring (13), and two compression rings (14 and 15) with engine oil. Using piston ring expander, install oil ring expander, oil ring, and two compression rings on piston (11) with dots or TOP facing up and oil ring gaps offset.
6. Slide upper sleeve bearing half (8) in place on connecting rod (9). Ensure that tang on upper sleeve bearing half fits in locking groove in connecting rod. Lubricate upper sleeve bearing half with engine oil.
7. Slide lower sleeve bearing half (4) in place on connecting rod bearing cap (5). Ensure that tang on lower sleeve bearing half fits in locking groove in connecting rod bearing cap. Lubricate lower sleeve bearing half with engine oil.

e. INSTALLATION

1. Using hinged handle and 3/4 in. socket, turn crankshaft screw (19) until mating crankshaft journal (3) for desired piston and connecting rod is accessible.
2. Lubricate all mating surfaces of piston (11), connecting rod (9), and assembled parts with engine oil.

CAUTION

- **Pistons and connecting rods must be installed in same location from which they were removed. Failure to do so may damage parts.**
 - **Do not damage crankshaft journal when installing piston and connecting rod.**
3. Using piston ring compressor and ball-peen hammer, tap piston (11) and connecting rod (9) in place in cylinder sleeve (1). Ensure that the word FRONT on piston faces front of engine assembly.

3-11. PISTON, CONNECTING ROD, AND CONNECTING ROD BEARING MAINTENANCE (Con't).

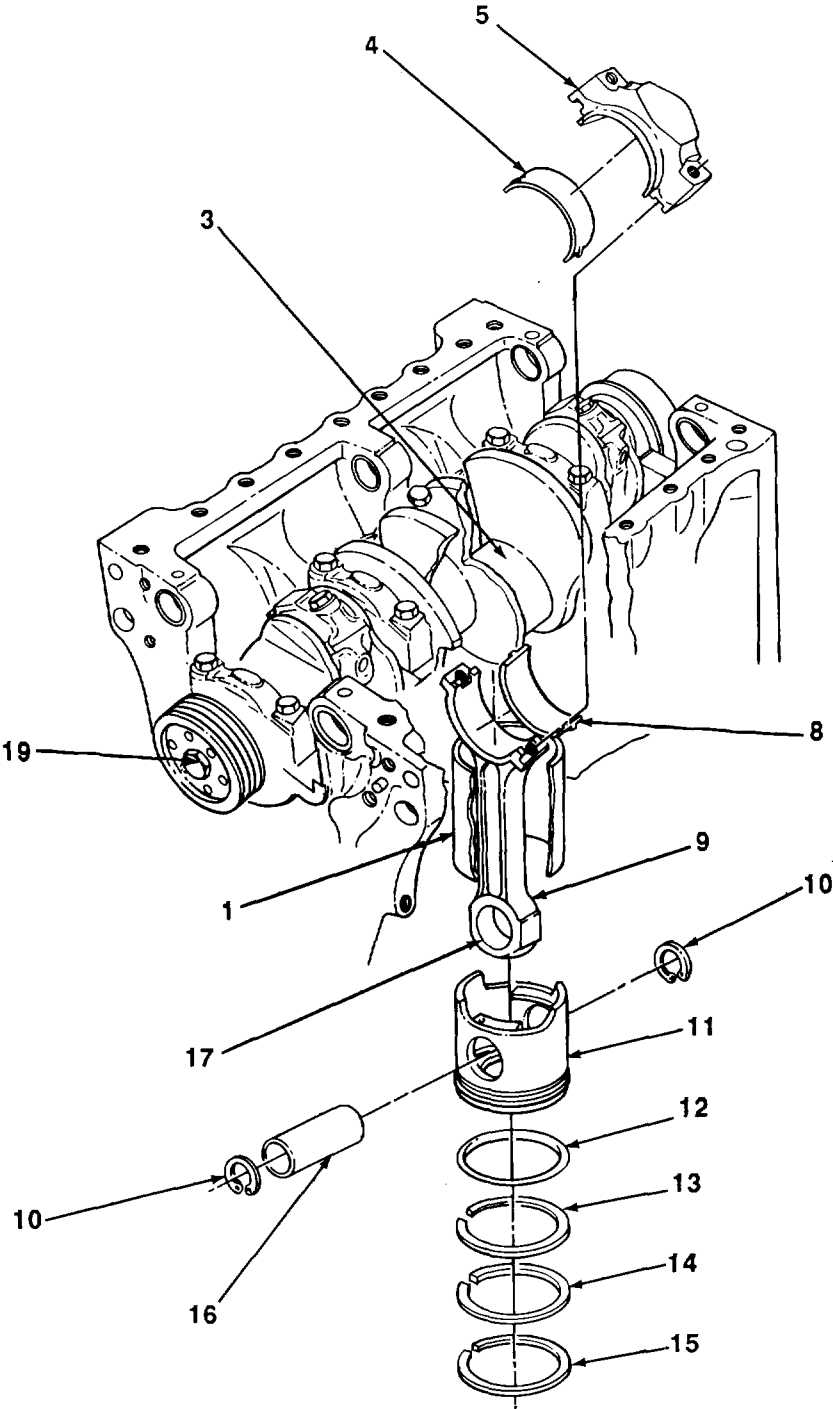

3-11. PISTON, CONNECTING ROD, AND CONNECTING ROD BEARING MAINTENANCE (Con't).

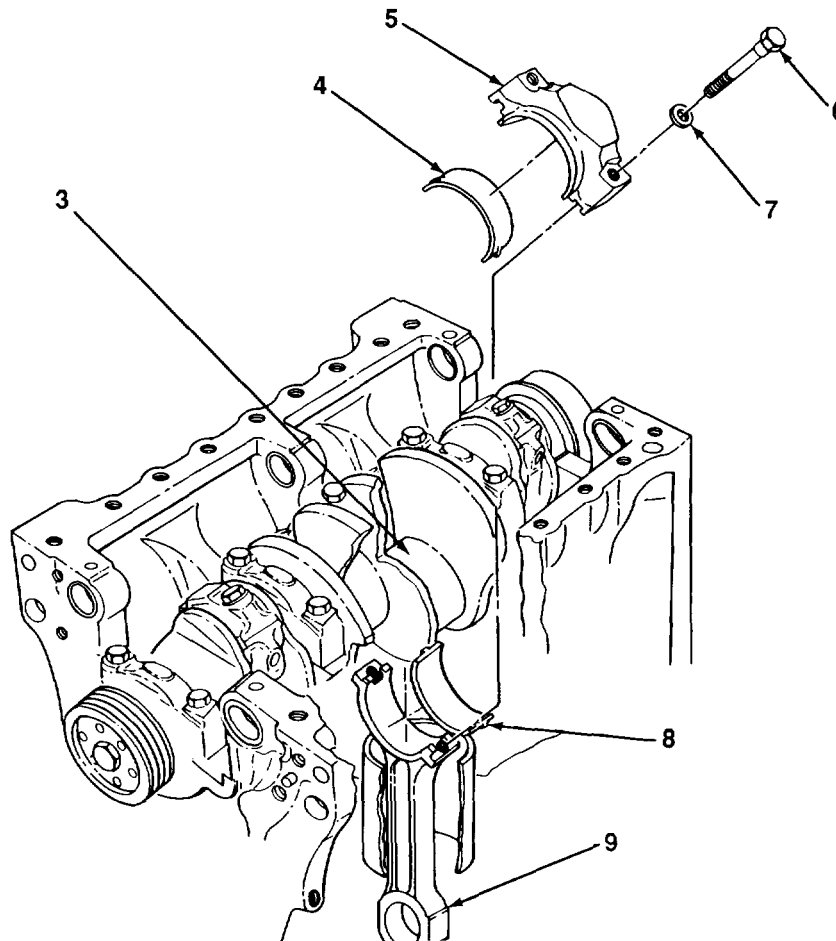

4. Position connecting rod bearing cap (5) with assembled lower sleeve bearing half (4) in place on crankshaft journal (3) and connecting rod (9) and assembled upper sleeve bearing half (8).
5. Coat threads of two bolts (6) with engine oil. Install bolts and washers (7) in connecting rod bearing cap (5) and connecting rod (9). Torque bolts to 65 lb.-ft. (88 N•m).

FOLLOW-ON TASKS:

- Install engine oil pan (see paragraph 3-20).
- Install cylinder head (see paragraph 3-6).
- Install engine assembly (see paragraph 3-3).

TA701268

3-12. VALVE MAINTENANCE.*This Task Covers:*

- | | | |
|----------------------------|----|-----------------|
| a. Removal | c. | Repair |
| b. Cleaning and Inspection | | d. Installation |

*Initial Setup:***Equipment Conditions:**

- Rocker arm, shaft, and pushrods removed (see paragraph 3-13).
- Cylinder head removed (see paragraph 3-6).

Tools/Test Equipment:

- General mechanic's tool kit
- Field automotive shop set

Materials/Parts:

- Carbon removing compound (Item 8, Appendix B)
- Prussian blue dye (Item 14, Appendix B)
- Engine oil (Item 25, Appendix B)
- Rags (Item 28, Appendix B)
- Dry cleaning solvent (Item 31, Appendix B)

General Safety Instructions:

- Dry cleaning solvent is flammable and must not be used near open flame. Use only in a well-ventilated area.
- Compressed air used for cleaning purposes should never exceed 30 psi (207 kPa).

NOTE

All intake and exhaust valves are maintained the same way. One is shown. Repeat procedure for other valves as required

a. REMOVAL

1. Remove valve seat (5) from top of valve (6).
2. Using valve spring lifter, compress valve spring (2).

CAUTION

Valve may be loose and could fall out of cylinder head. Ensure that valve does not fall out or damage to parts may result.

3. Remove exhaust valve cap (3) from valve (6) and valve lock (4).
4. Remove valve spring lifter, valve lock (4), and spring (2) from cylinder head (1) and valve (6).

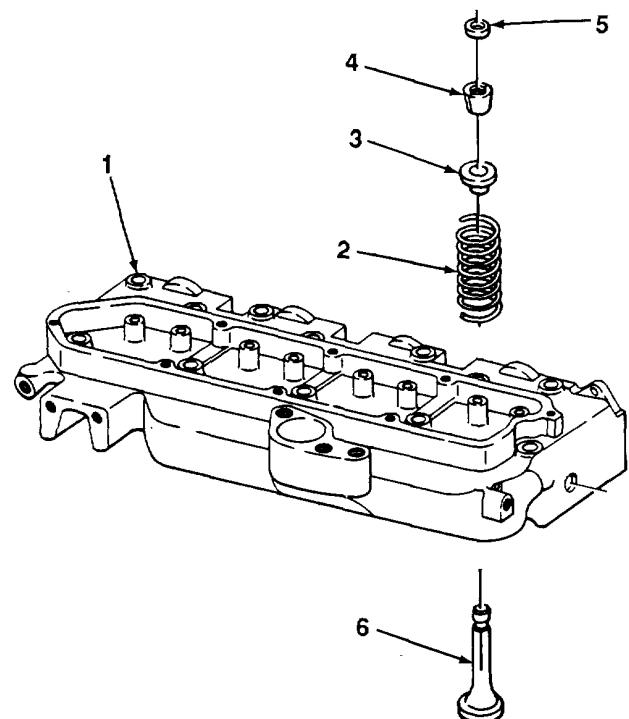

TA701269

3-12. VALVE MAINTENANCE (Con't).**CAUTION**

Do not nick or scratch surface between valve face and stem. A small nick can cause valve head to break off during operation.

5. Slide valve (6) out of cylinder head (1).

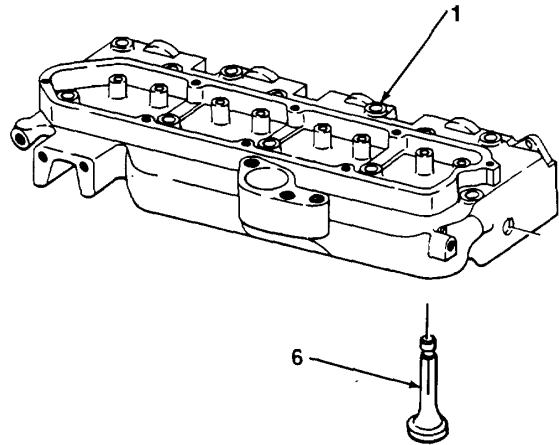
**b. CLEANING AND INSPECTION****WARNING**

Carbon removing compound is a corrosive liquid. If splashed in eyes, it can cause blindness. If splashed on skin, it can cause serious burns. Be sure to wear safety goggles or lenses, rubber apron, and rubber gloves. If accidentally splashed in eyes or on skin, flush with clean, cool water, refer to FM 21-11 for first aid information, and get medical attention immediately.

1. Soak valve overnight in carbon removing compound.

WARNING

Compressed air used for cleaning or drying purposes, or for clearing restrictions, should never exceed 30 psi (207 kPa). Wear protective clothing (goggles/shield, gloves, etc.) and use caution to avoid injury to personnel.

2. Using paint brush and hot water, clean carbon deposits off valve, then dry with compressed air.

WARNING

Dry cleaning solvent, P-D-680, is toxic and flammable. Always wear protective goggles and gloves, and use only in a well-ventilated area. Avoid contact with skin, eyes, and clothes, and DO NOT breathe vapors. DO NOT use near open flame or excessive heat. The solvent's flash point is 100°F-138°F (38°C-59°C). If you become dizzy while using cleaning solvent, immediately get fresh air and medical help. If solvent contacts eyes, immediately wash your eyes and get medical aid.

3. Clean valve spring, valve lock, exhaust valve cap, and valve seat with dry cleaning solvent. Dry thoroughly with clean rags.

TA701270

3-12. VALVE MAINTENANCE (Con't).

4. Inspect valve, valve spring, valve lock, exhaust valve cap, and valve seat for cracks, breaks, scoring, and excessive wear. Replace defective parts.
5. Using micrometer caliper set, measure outside diameter of valve head. Outside diameter for intake valve must be 1.767-1.777 in. (44.882-45.136 mm). Outside diameter for exhaust valve must be 1.570-1.580 in. (39.878-40.132 mm).
6. Using micrometer caliper set, measure length of valve. Length must be 5.1340-5.1740 in. (130.4036-131.4196 mm).
7. Using micrometer caliper set, measure diameter of valve stem. Refer to Table 3-2 for valve stem diameter specifications.
8. Using telescoping gage set and vernier caliper, measure inside diameter of valve guide in cylinder head. Refer to Table 3-2 for valve guide diameter specifications.
9. Subtract measurement taken in step 7 from measurement taken in step 8. The difference is valve stem-to-guide clearance. Clearance must be 0.0020-0.0060 in. (0.0508-0.1524 mm).

Table 3-2. Valve Guide and Stem Diameter Specifications.

Valve Stem Type (Inches)	Valve Guide Diameter In Inches (mm)	Valve Stem Diameter In Inches (mm)
Standard	0.3745-0.3765 (9.5123-9.5631)	0.3715-0.3725 (9.4361-9.4615)
0.003 Oversize	0.3748-0.3768 (9.5199-9.5707)	0.3718-0.3728 (9.4437-9.4691)
0.015 Oversize	0.3760-0.3780 (9.5504-9.6012)	0.3730-0.3740 (9.4742-9.4996)
0.030 Oversize	0.3775-0.3795 (9.5885-9.6393)	0.3745-0.3755 (9.5123-9.5377)

10. Using spring tester and torque wrench, compress valve spring to 1.8125 in. (46.0375 mm) and note compression force on torque wrench. Compression force must be 54-62 lb.-ft. (73-84 N•m).
11. Using spring tester and torque wrench, compress valve spring to 1.3594 in. (34.5288 mm) and note compression force on torque wrench. Compression force must be 133-153 lb.-ft. (180-207 N•m).
12. Position valve in place in cylinder head. Using micrometer depth gage, measure distance from cylinder head deck to valve. Distance must be 0.023-0.047 in. (0.584-1.194 mm) for intake valve and 0.038-0.072 in. (0.965-1.829 mm) for exhaust valve.
13. Remove valve from cylinder head. Apply thin coat of Prussian blue dye to valve face. Position valve in place in cylinder head.
14. Turn valve one complete revolution, then remove valve from cylinder head.
15. Inspect valve for low spots or evidence of poor contact between valve and cylinder head. Low spots will be free of Prussian blue dye. If contact is poor, repair cylinder head (see paragraph 3-6) and valve as required.

3-12. VALVE MAINTENANCE (Con't).**c. REPAIR****NOTE**

Follow valve grinding equipment manufacturer's instructions for proper use of equipment when refacing valve.

Using valve face grinding machine, reface valve (6). Valve face must be ground to an angle of 43° 15'-43° 45' (0.757-0.766 rad).

d. INSTALLATION

1. Lubricate valve stem with engine oil. Slide valve (6) in cylinder head (1) and hold in position. Ensure that valve stem slides up and down in valve guide without resistance.
2. Position valve spring (2) and valve lock (4) in place on valve (6) and cylinder head (1).
3. Using valve spring lifter, compress valve spring (2). Install exhaust valve cap (3) on valve (6), then remove valve spring lifter.
4. Install valve seat (5) on top of valve (6). Using plastic-faced hammer, tap on valve three or four times to seat valve lock (4).

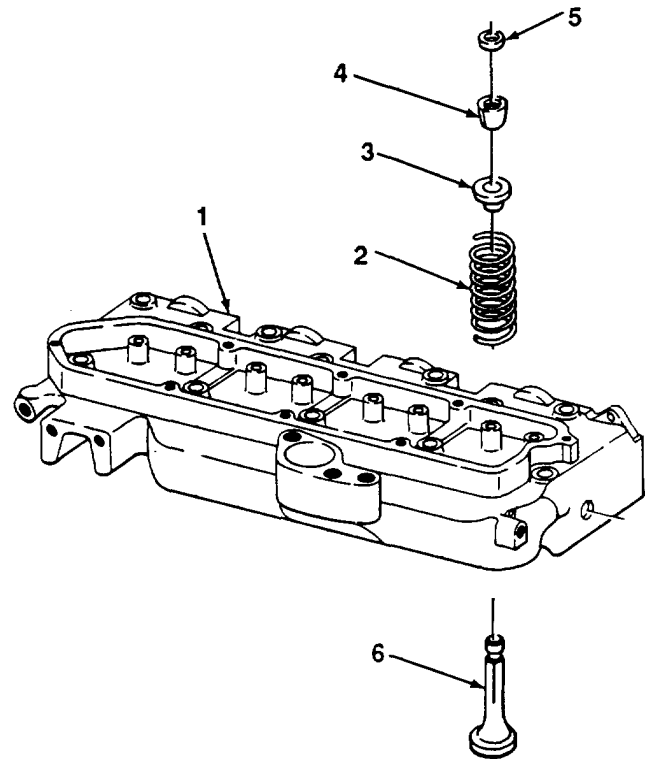
**FOLLOW-ON TASKS:**

- Install cylinder head (see paragraph 3-6).
- Install rocker arm, shaft, and pushrods (see paragraph 3-13.)

3-13. ROCKER ARM, SHAFT, AND PUSHROD MAINTENANCE.

This Task Covers:

- | | | |
|----------------------------|----|-----------------|
| a. Removal | d. | Assembly |
| b. Disassembly | | e. Installation |
| c. Cleaning and Inspection | | |
-

*Initial Setup:***Equipment Conditions:**

- Rocker arm cover removed (see TM 5-2420-222-20).

Tools/Test Equipment:

- General mechanic's tool kit
- Field automotive shop set

Materials/Parts:

- Abrasive cloth (Item 6, Appendix B)
- Engine oil (Item 25, Appendix B)
- Rags (Item 28, Appendix B)
- Dry cleaning solvent (Item 31, Appendix B)
- Marker tags (Item 32, Appendix B)
- Nonelectrical wire (Item 44, Appendix B)

General Safety Instructions

- Dry cleaning solvent is flammable and must not be used near open flame. Use only in a well-ventilated area.
-

3-13. ROCKER ARM, SHAFT, AND PUSHROD MAINTENANCE (Con't).

a. REMOVAL

1. Remove four screws (1) and washers (2) from four rocker arm supports (4) and cylinder head (5).
2. Remove rocker arm shaft (3) and assembled parts from cylinder head (5).

CAUTION

Pushrods must be installed in same position from which they are removed. Improper installation may damage parts.

3. Remove eight pushrods (7) from cylinder head (5) and eight tappets (6).

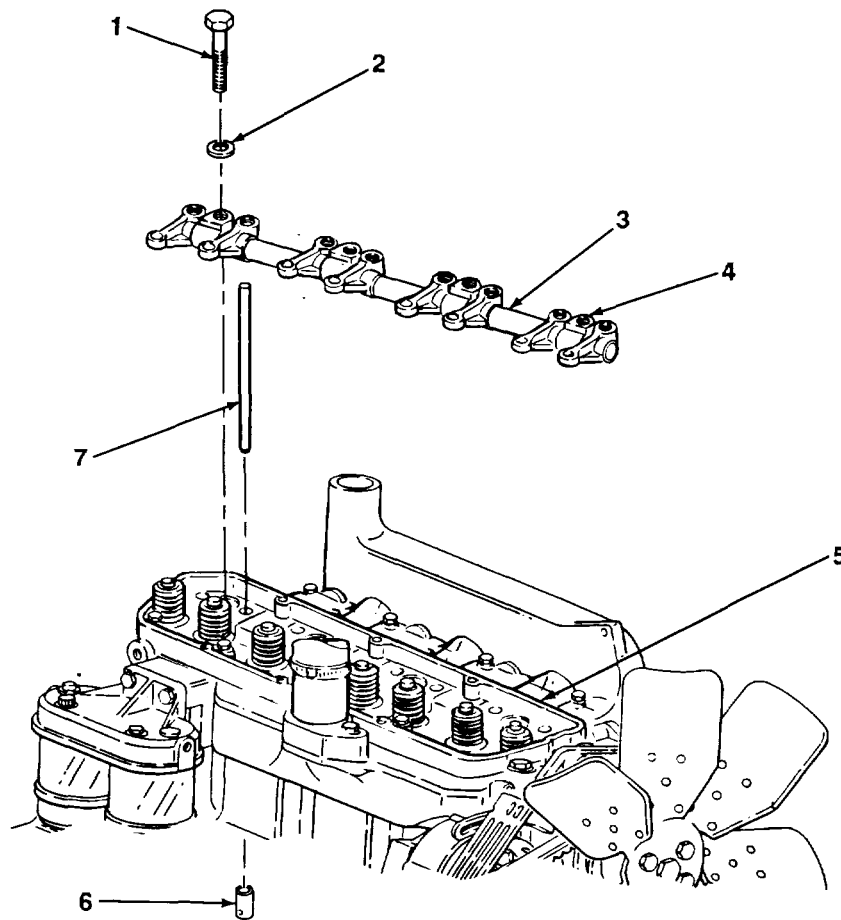

b. DISASSEMBLY

1. Position rocker arm shaft (3) and assembled parts in a vise with soft jaw caps.
2. Remove two plugs (8) and washers (9) from ends of rocker arm shaft (3).

3-13. ROCKER ARM, SHAFT, AND PUSHROD MAINTENANCE (Con't).

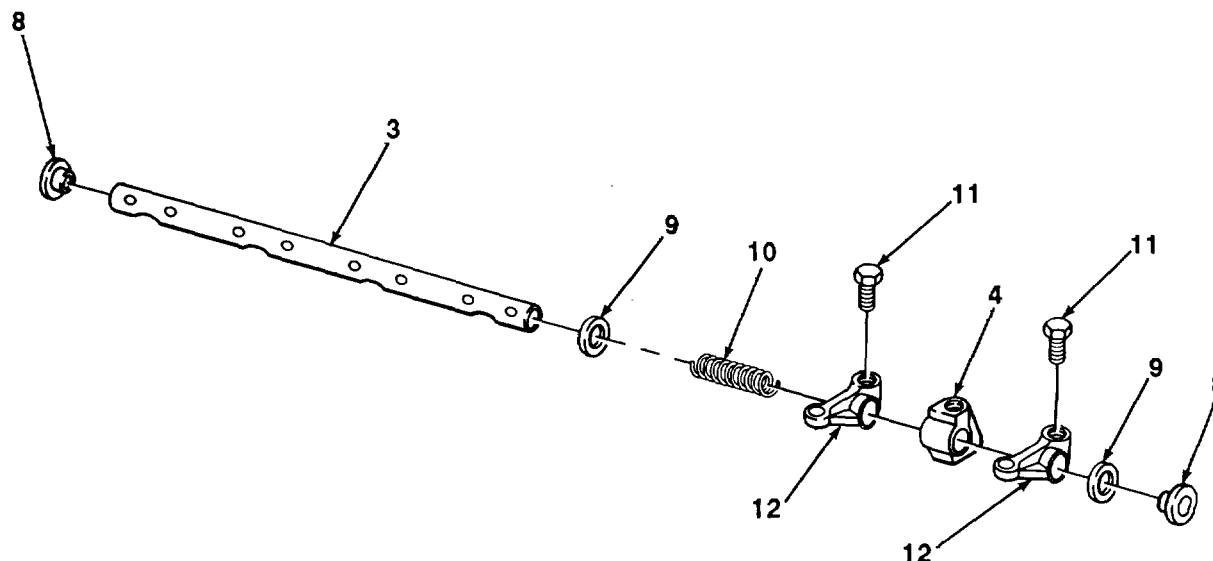

CAUTION

Rocker arms and rocker arm supports must be assembled in same position from which they are disassembled. Improper assembly may damage parts.

3. Tag and remove eight rocker arms (12), four rocker arm supports (4), and three springs (10).
4. Remove eight adjusting screws (11) from rocker arms (12).

c. CLEANING AND INSPECTION

WARNING

Dry cleaning solvent, P-D-680, is toxic and flammable. Always wear protective goggles and gloves, and use only in a well-ventilated area. Avoid contact with skin, eyes, and clothes, and DO NOT breathe vapors. DO NOT use near open flame or excessive heat. The solvent's flash point is 100°F-138°F (38°C-59°C). If you become dizzy while using cleaning solvent, immediately get fresh air and medical help. If solvent contacts eyes, immediately wash your eyes and get medical aid.

1. Clean parts with dry cleaning solvent, nonelectrical wire, and abrasive cloth, then dry thoroughly with a clean, dry rag.
2. Inspect parts for cracks, bends, or breaks. Replace defective parts.
3. Using micrometer, check outside diameter of rocker arm shaft at wear points. Outside diameter must be 0.7869-0.7899 in. (19.9873-20.0635 mm). Replace if defective.
4. Using calipers, check bore diameter of eight rocker arms. Bore diameter must be 0.7900-0.7940 in. (20.0660-20.1676 mm). Replace if defective.
5. Using spring tester and torque wrench, compress three springs to 1.8125 in. (46.0375 mm) and note compression force on torque wrench. Compression force must be 48-72 lb.-ft. (5.4-8.1 N•m). Replace if defective.

TA701273

3-13. ROCKER ARM, SHAFT, AND PUSHROD MAINTENANCE (Con't).**d. ASSEMBLY**

1. Install eight adjusting screws (11) in rocker arms (12).
2. Apply light coat of engine oil to eight rocker arms (12), pushrods (7), four rocker arm supports (4), and three springs (10).

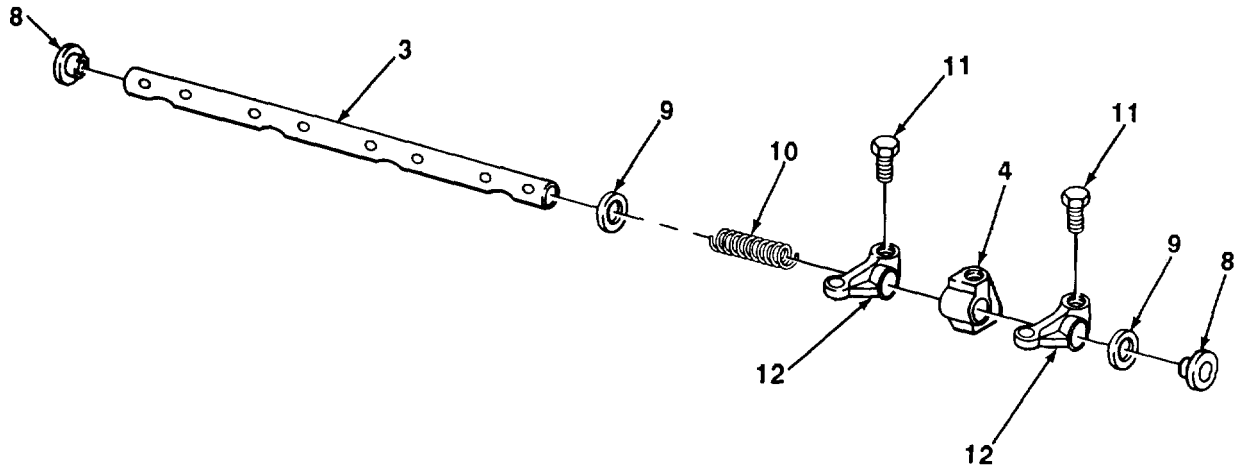
**CAUTION**

Rocker arms and rocker arm supports must be assembled in same position from which they were disassembled. Improper assembly may damage parts.

3. Install eight rocker arms (12), four rocker arm supports (4), and three springs (10) on rocker arm shaft (3).
4. Using plastic-faced hammer, install two washers (9) and plugs (8) in ends of rocker arm shaft (3).

e. INSTALLATION**CAUTION**

Pushrods must be installed in same position from which they were removed. Improper installation may damage parts.

1. Install eight pushrods (7) in cylinder head (5) and eight tappets (6).
2. Position rocker arm shaft (3) with rocker arm supports (4) and assembled parts in place on cylinder head (5). Ensure that cutouts in rocker arm shaft align with screw holes in rocker arm supports.
3. Install four washers (2) and screws (1) to secure rocker arm supports (4) to cylinder head (5). Torque screws to 35 lb.-ft. (47 N•m).

TA701274

3-13. ROCKER ARM, SHAFT, AND PUSHROD MAINTENANCE (Con't).

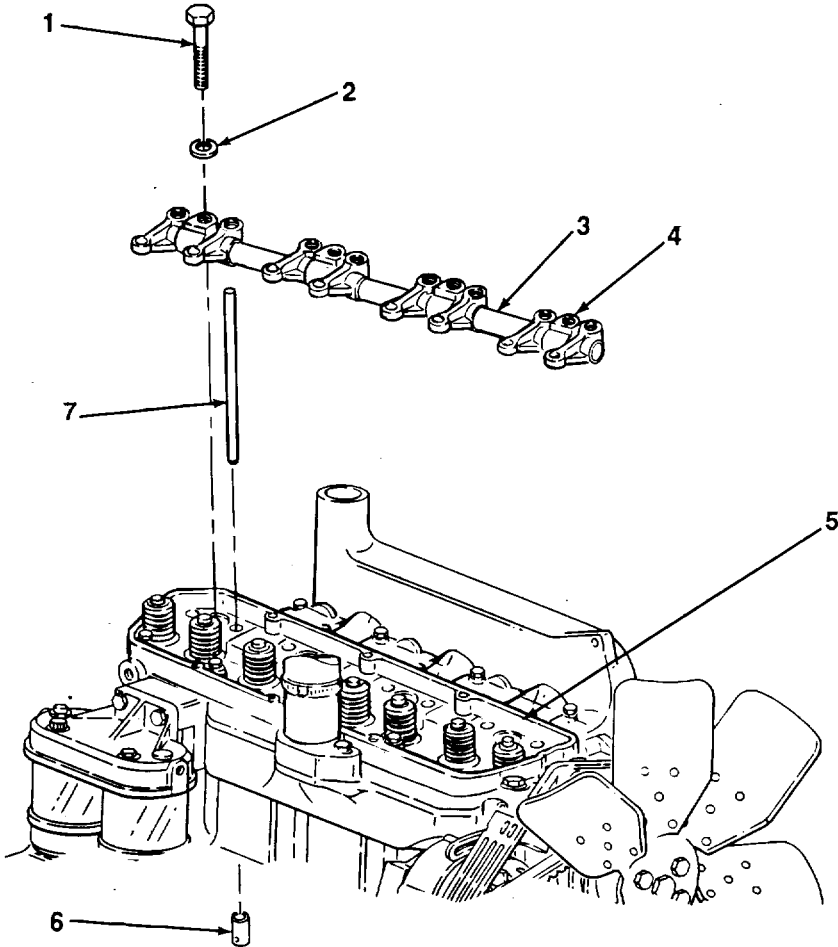

FOLLOW-ON TASKS:

- Adjust valves (see TM 5-2420-222-20).
- Install rocker arm cover (see TM 5-2420-222-20).

TA701275

3-14. TAPPET REPLACEMENT.

This Task Covers:

- | | | | |
|----|-------------------------|----|--------------|
| a. | Removal | c. | Installation |
| b. | Cleaning and Inspection | | |

Initial Setup:

Equipment Conditions:

- Cylinder head removed (see paragraph 3-6).

Tools/Test Equipment:

- General mechanic's tool kit
- Field automotive shop set

Materials/Parts:

- Engine oil (Item 25, Appendix B)
- Dry cleaning solvent (Item 31, Appendix B)
- Marker tags (Item 32, Appendix B)
- Nonelectrical wire (Item 44, Appendix B)

General Safety Instructions:

- Dry cleaning solvent is flammable and must not be used near open flame. Use only in a well-ventilated area.
- Compressed air used for cleaning purposes should never exceed 30 psi (207 kPa).

a. REMOVAL**CAUTION**

Tappets must be installed in same bore from which they are removed. Improper installation may damage parts.

Using magnetic retrieving tool, remove eight tappets (2) from engine block (1) and camshaft (3).

b. CLEANING AND INSPECTION**WARNING**

- Dry cleaning solvent, P-D-680, is toxic and flammable. Always wear protective goggles and gloves, and use only in a well-ventilated area. Avoid contact with skin, eyes, and clothes, and DO NOT breathe vapors. DO NOT use near open flame or excessive heat. The solvent's flash point is 100°F-138°F (38°C-59°C). If you become dizzy while using cleaning solvent, immediately get fresh air and medical help. If solvent contacts eyes, immediately wash your eyes and get medical aid.
- Compressed air used for cleaning or drying purposes, or for clearing restrictions, should never exceed 30 psi (207 kPa). Wear protective clothing (goggles/shield, gloves, etc.) and use caution to avoid injury to personnel.

1. Clean tappets in dry cleaning solvent and dry with compressed air.
2. Inspect tappets for cracks, bends, breaks, and excessive wear. Replace defective parts.

3-14. TAPPET REPLACEMENT (Con't).

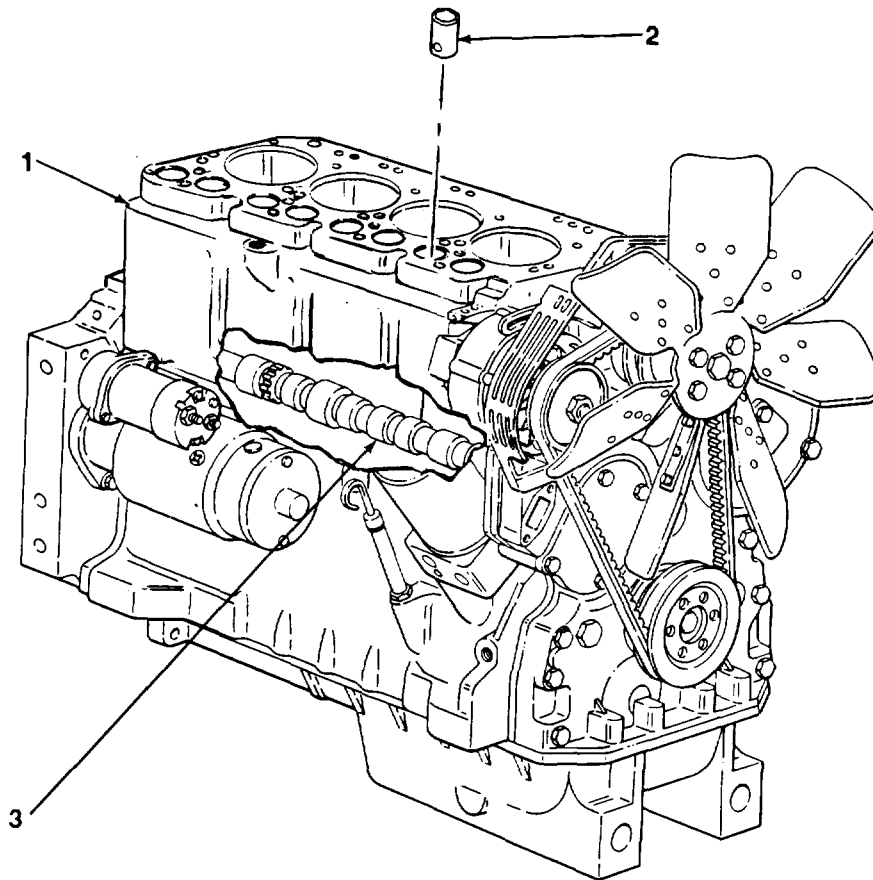
**c. INSTALLATION****CAUTION**

- Tappets must be Installed in same bore from which they were removed. Improper installation may damage parts.
- When Installing tappets, ensure that tappets do not fall down through bore. Do not scratch bore with nonelectrical wire. This may damage parts.

1. Lubricate eight tappets (2) with engine oil.
2. Using nonelectrical wire with a 90° bend in end, lower eight tappets (2) in engine block (1) until they rest on camshaft (3).

FOLLOW-ON TASKS:

- Install cylinder head (see paragraph 3-6).

TA701276

3-15. IDLER GEARS REPLACEMENT.*This Task Covers:*

- | | |
|----------------------------|-----------------|
| a. Removal | d. Assembly |
| b. Disassembly | e. Installation |
| c. Cleaning and Inspection | |
| d. | |

*Initial Setup:***Equipment Conditions:**

- Timing gear cover removed (see paragraph 3-18).

Tools/Test Equipment:

- General mechanic's tool kit
- Field automotive shop set
- Timing alignment tool

Materials/Parts:

- Engine oil (Item 25, Appendix B)
- Rags (Item 28, Appendix B)
- Dry cleaning solvent (Item 31, Appendix B)
- Nonelectrical wire (Item 44, Appendix B)
- General mechanic's tool kit

General Safety Instructions:

- Dry cleaning solvent is flammable and must not be used near open flame. Use only in a well-ventilated area.

a. REMOVAL**CAUTION**

To avoid damage to pistons and valves, do not crank engine assembly with any timing components removed.

1. Pry lower idler spur gear (5) on lower idler gearshaft (3) away from cylinder block plate (1) as far as possible.
2. Using dial indicator, measure and record end play of lower idler spur gear (5). End play must be 0.0010-0.0220 in. (0.0254-0.5588 mm).
3. Remove bolt (9) and washer (8) from lower idler gearshaft (3).
4. Remove thrust washer bearing (7) from lower idler spur gear (5) and spring pin (4).

NOTE

When removing lower idler spur gear, ensure that other gears do not turn.

5. Remove lower idler spur gear (5) and sleeve bearing (6) from lower idler gearshaft (3).

NOTE

Perform steps 6 through 9 only if lower idler gearshaft is damaged.

6. Remove engine oil pan (see paragraph 3-20).
7. Remove bolt (11) and washer (10) from cylinder block plate (1) and lower idler gearshaft (3).
8. Alternately pry and tap lower idler gearshaft (3) from side to side until it can be removed from cylinder block plate (1).
9. Remove washer (2) from lower idler gearshaft (3) and spring pin (4).

3-15. IDLER GEARS REPLACEMENT (Con't).

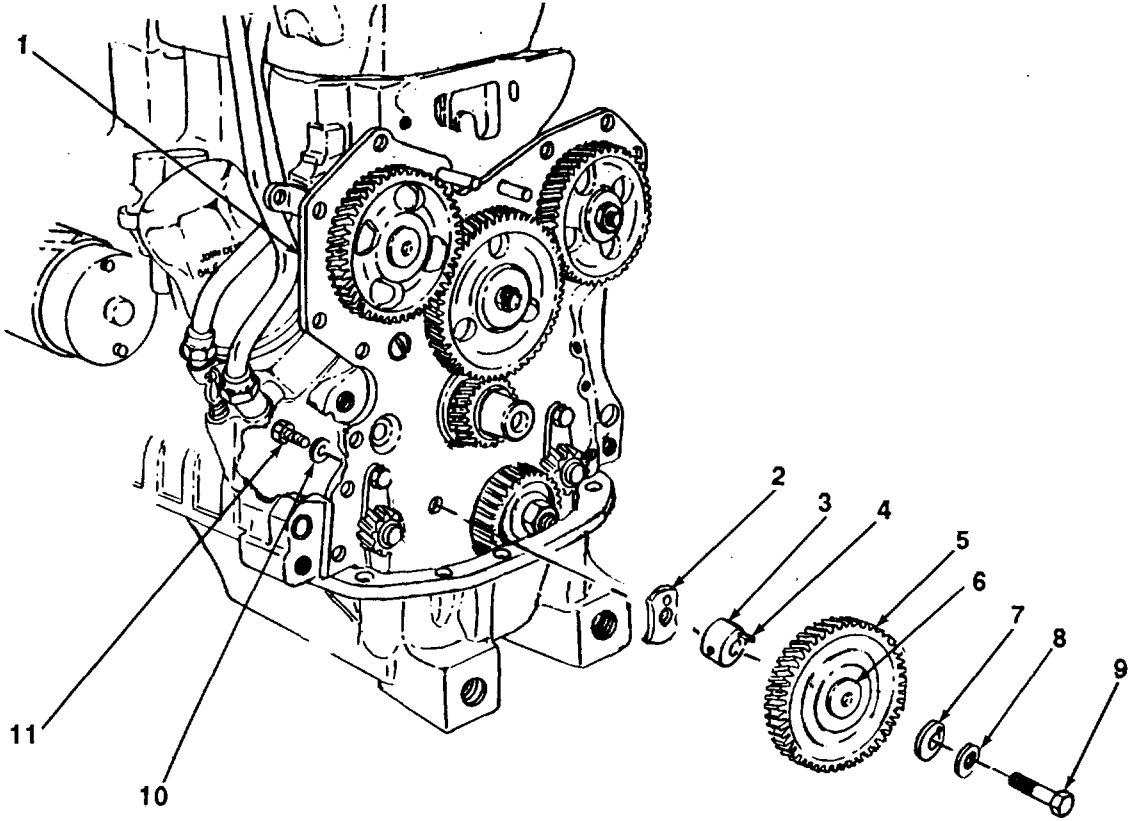

3-15. IDLER GEARS REPLACEMENT (Con't).

10. Pry upper idler spur gear (16) on upper idler gearshaft (14) away from cylinder block plate (1) as far as possible.
11. Using dial indicator, measure and record end play of upper idler spur gear (16). End play must be 0.0010-0.0220 in. (0.0254-0.5588 mm).
12. Remove bolt (19) from upper idler gearshaft (14), washer (13), and cylinder block plate (1).
13. Remove thrust washer bearing (18) from upper idler spur gear (16) and spring pin (15).
14. Remove woodruff key (20) and deflector (21) from crankshaft (23).

NOTE

When removing upper idler spur gear, ensure that other gears do not turn.

15. Remove upper idler spur gear (16) and sleeve bearing (17) from upper idler gearshaft (14).
16. Pry upper idler gearshaft (14) out of cylinder block plate (1). Remove washer (13) from upper idler gearshaft and spring pin (15).

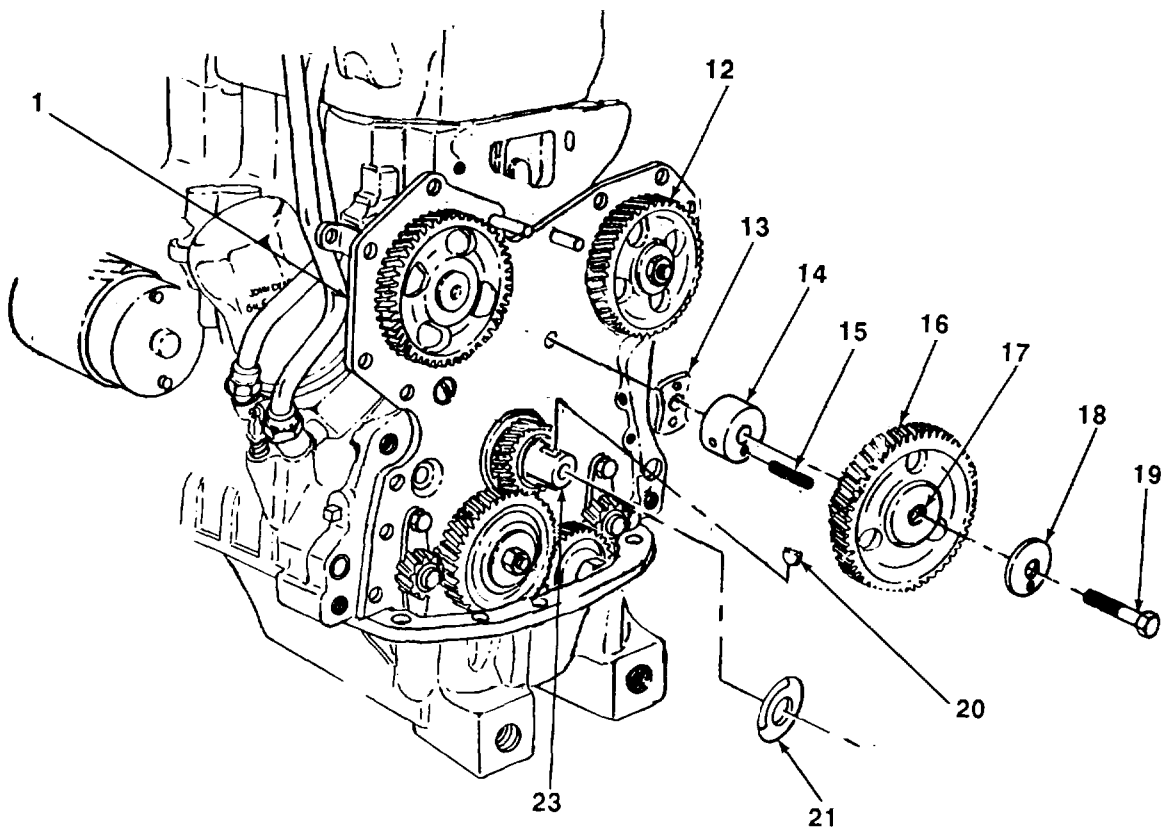

3-15. IDLER GEARS REPLACEMENT (Con't).**b. DISASSEMBLY****CAUTION**

Do not remove spring pins unless damaged.
Removal may damage parts.

NOTE

Step applies to either upper or lower idler gearshaft. Lower idler gear-shaft is shown.

Drive spring pin (4) out of lower idler gearshaft (3).

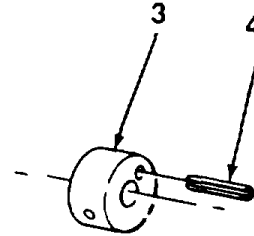
**c. CLEANING AND INSPECTION****WARNING**

Dry cleaning solvent, P-D680, is toxic and flammable. Always wear protective goggles and gloves, and use only in a well-ventilated area. Avoid contact with skin, eyes and clothes, and DO NOT breathe vapors. DO NOT use near open flame or excessive heat. The solvent's flash point is 100° F - 138° F (38C-59C). If you become dizzy while using cleaning solvent, immediately get fresh air and medical help. If solvent contacts eyes, immediately wash your eyes and get medical aid.

1. Clean upper and lower idler spur gears with dry cleaning solvent.
2. Clean oil passage holes with nonelectrical wire and flush with dry cleaning solvent. Dry with clean rags.
3. Clean all other parts with dry cleaning solvent. Dry with clean rag.
4. Inspect all metal parts for cracks, bends, or breaks. Replace all defective parts.
5. Inspect all threaded parts for damaged threads. Restore damaged threads using screw threading set.
6. Inspect upper and lower idler spur gears for burrs, abnormal wear, and damaged teeth. Remove burrs with sharpening stone. Replace if defective.
7. Using micrometer caliper set, measure width of upper and lower idler spur gears at hub. Width must be 0.8650-0.8690 in. (21.9710-22.0726 mm).

NOTE

If upper or lower idler gearshaft needs replacing, spring pin must also be replaced.

8. Using vernier caliper, measure outside diameter of upper or lower idler gearshaft (3 or 14). Outside diameter must be 1.7495-1.7515 in. (44.4373-44.4881 mm).

3-15. IDLER GEARS REPLACEMENT (Con't).

9. Using vernier caliper, measure length of upper or lower idler gearshaft (3 or 14). Length must be 0.8680-0.8740 in. (22.0472-22.1996 mm).
10. Inspect sleeve bearings for grooves. Using vernier calipers, measure inside diameter. Inside diameter must be 1.7520-1.7540 in. (44.5008-44.5516 mm). If damaged, replace upper or lower idler spur gear.
11. If end play recorded in steps 2 and 11 of removal was not as specified and idler spur gears are within specification, replace thrust washer bearing and washer.

d. ASSEMBLY**NOTE**

**Step applies only if spring pin was removed.
Lower Idler gearshaft is shown.**

Tap spring pin (4) in lower idler gearshaft (3) until spring pin extends beyond surface of shaft 0.200-0.280 in. (5.080-7.112 mm).

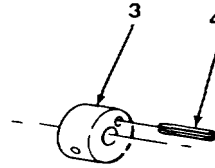
**e. INSTALLATION**

1. Install washer (13) in place on upper idler gearshaft (14) and spring pin (15).
2. Lubricate upper idler gearshaft (14) and assembled parts with engine oil. Tap upper idler gearshaft in place in cylinder block plate (1).
3. Using timing alinement tool, aline timing marks on fuel injection pump helical gear (12), camshaft helical gear (25), and crankshaft (23).

NOTE

When Installing upper idler spur gear, do not turn other gears.

4. Lubricate sleeve bearing (17) in upper idler spur gear (16) with engine oil. Install upper idler spur gear and sleeve bearing in place on upper idler gearshaft (14).
5. Slide deflector (21) on crankshaft (23), then tap woodruff key (20) in place in crankshaft.
6. Install thrust washer bearing (18) and bolt (19) in upper idler gearshaft (14). Torque bolt to 65 lb.-ft. (88 N•m).

TA701280

3-15. IDLER GEARS REPLACEMENT (Con't).

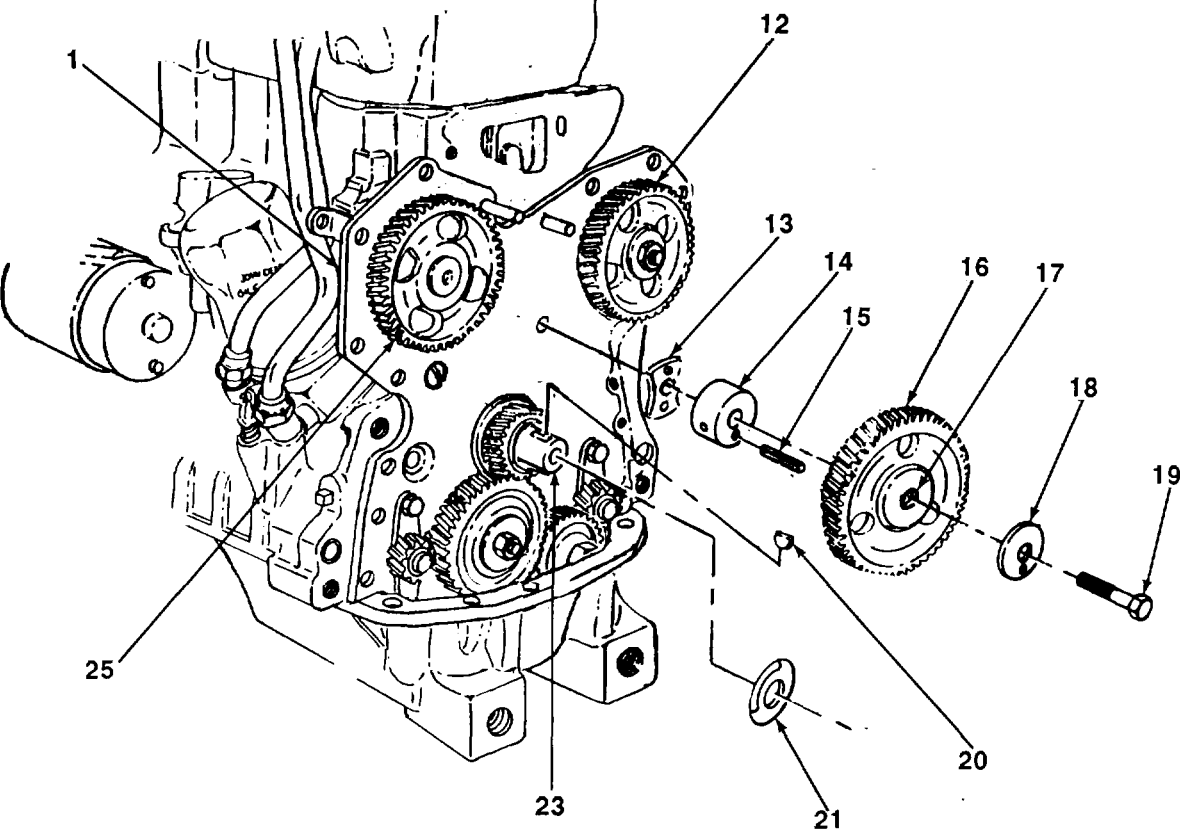

TA701281

3-15. IDLER GEARS REPLACEMENT (Con't).**NOTE**

Perform steps 7 through 10 only if lower idler gearshaft was replaced.

7. Install washer (2) in place on lower idler gearshaft (3) and spring pin (4).
8. Lubricate lower idler gearshaft (3) and assembled parts with engine oil. Tap lower idler gearshaft in place in cylinder block plate (1).
9. Install washer (1nC and bolt (11) in lower idler gearshaft (3) and cylinder block elate (1).

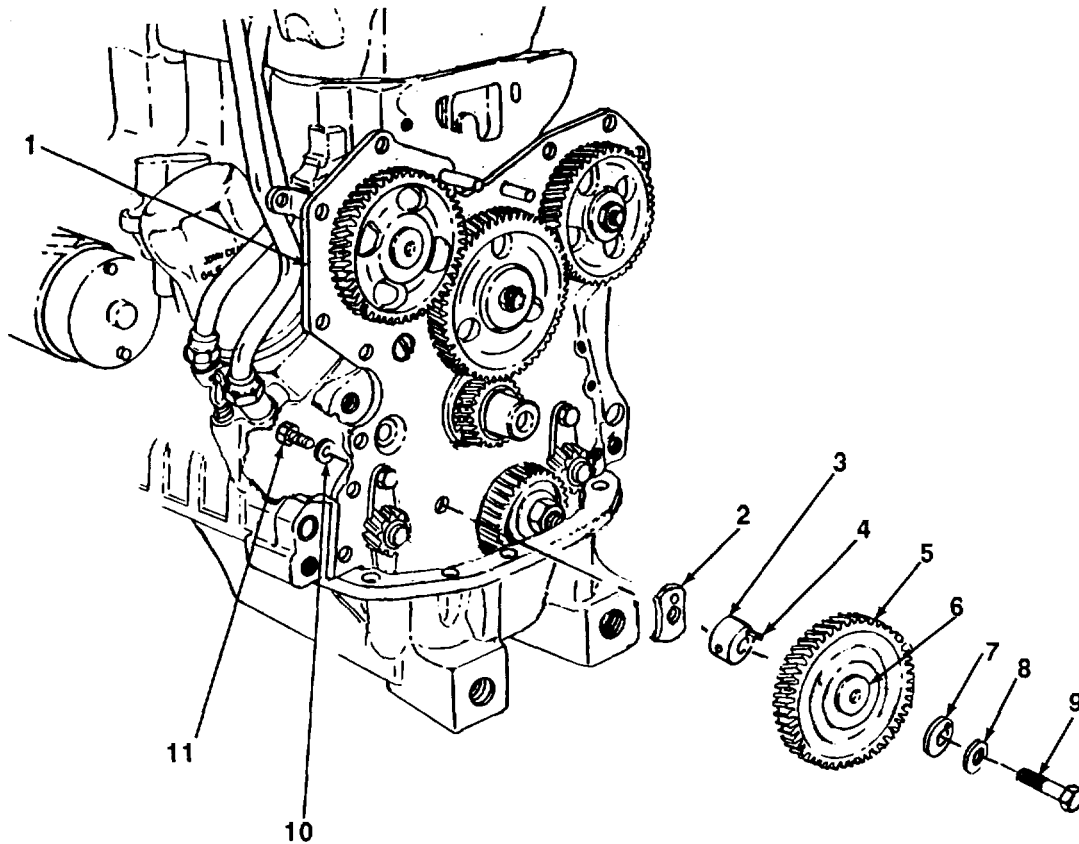

TA701282

3-15. IDLER GEARS REPLACEMENT (Con't).

10. Install engine oil pan (see paragraph 3-20).
11. Using timing alignment tool, aline timing marks on right-hand control cam spur gear (24), engine oil pump spur gear (22), and crankshaft (23).

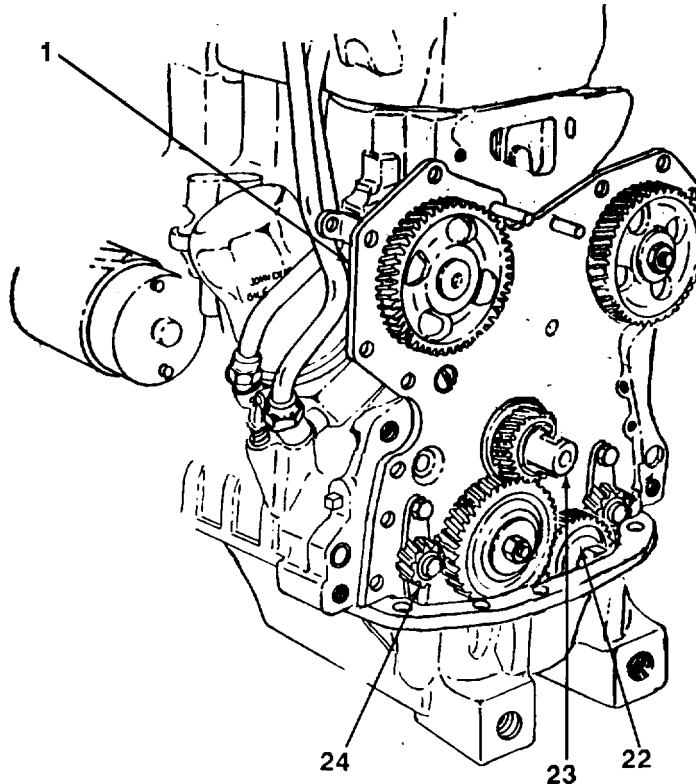
**NOTE**

When installing lower idler spur gear, do not turn other gears.

12. Lubricate sleeve bearing (6) in lower idler spur gear (5) with engine oil. Install lower idler spur gear and sleeve bearing in place on lower idler gearshaft (3).
13. Install thrust washer bearing (7), washer (8), and bolt (9) in lower idler gearshaft (3). Torque bolt to 65 lb.-ft. (88 N•m).

FOLLOW-ON TASKS:

- Time engine (see paragraph 3-16).

3-16. ENGINE TIMING.*This Task Covers: Adjustment**Initial Setup:***Equipment Conditions:**

- Rocker arm cover removed (see TM 5-2400-222-20).

Tools/Test Equipment:

- General mechanic's tool kit
- Field automotive shop set

NOTE

Timing gears are marked for ease of installation. Marks on timing gears consist of slash-marks stamped on all faces except the idler spur gears. When slash-marks on gear faces align with center of crankshaft, with no. 1 cylinder at top dead center (TDC), as illustrated, gears are timed correctly.

ADJUSTMENT**NOTE**

Cylinders are numbered from one to four starting at fan end of engine assembly.

1. Remove pin (1) and cover (2) from flywheel housing (4).
2. Manually crank engine assembly until no. 1 cylinder is at TDC and hole in flywheel (3) is aligned with timing hole in flywheel housing (4).
3. Insert pin (1) timing hole in flywheel housing (4) until seated in hole in flywheel (3).
4. Remove timing gear cover (see paragraph 3-18).

NOTE

Steps 5 through 11 are performed with all gears installed in their proper locations.

5. Using dial indicator, measure upper idler spur gear (6) backlash. Backlash must be 0.0027- 0.0166 in. (0.0686-0.4216 mm). Adjust end play as required (see paragraph 3-15).
6. Using dial indicator, measure camshaft helical gear (11) backlash. Backlash must be 0.0028- 0.0185 in. (0.0711-0.4699 mm). Adjust end play as required (see paragraph 3-17).
7. Using dial indicator, measure fuel metering pump helical gear (5) backlash. Backlash must be 0.0028-0.0185 in. (0.0711-0.4699 mm). Adjust end play as required (see paragraph 5-3).
8. Using dial indicator, measure lower idler spur gear (10) backlash. Backlash must be 0.0027- 0.0187 in. (0.0686-0.4750 mm). Adjust end play as required (see paragraph 3-15).

3-16. ENGINE TIMING (Con't).

9. Using dial indicator, measure engine oil pump spur gear (8) backlash. Backlash must be 0.0016-0.0197 in. (0.0406-0.5004 mm). Adjust end play as required (see paragraph 3-21).
10. Using dial indicator, measure right-hand control cam spur gear (7) backlash. Backlash must be 0.0018-0.0206 in. (0.0457-0.5232 mm). Adjust end play as required (see paragraph 3-19).
11. Using dial indicator, measure left-hand control cam spur gear (9) backlash. Backlash must be 0.0020-0.0190 in. (0.0508-0.4826 mm). Adjust end play as required (see paragraph 3-19).
12. Install timing gear cover (see paragraph 3-18).
13. Remove pin (1) from flywheel housing (4) and flywheel (3).
14. Position cover (2) in place on flywheel housing (4) and install pin (1).

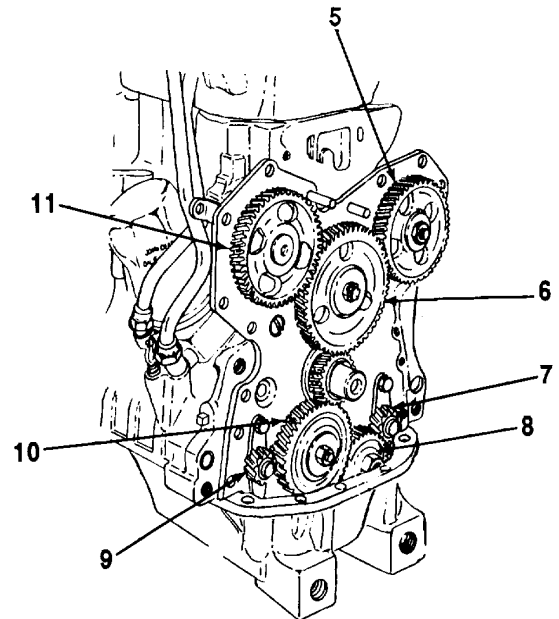
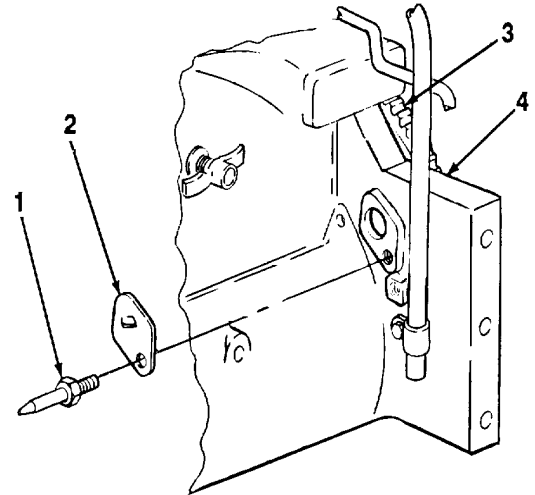
**FOLLOW-ON TASKS:**

- Install rocker arm cover (see TM 5-2420-222-20).

3-17. CAMSHAFT MAINTENANCE.

This Task Covers:

- | | |
|---------------------|----------------------------|
| a. Valve Lift Check | d. Cleaning and Inspection |
| b. Removal | e. Assembly |
| c. Disassembly | f. Installation |
| d. | |

Initial Setup:

Equipment Conditions:**NOTE**

Perform the following if performing valve lift check only.

- Rocker arm cover removed (see TM 5-2420-222-20).
- Valves adjusted (see TM 5-2420-222-20).

NOTE

Perform the following if removal, disassembly, cleaning and inspection, assembly, and installation are required.

- Upper idler spur gear removal (see paragraph 3-15).
- Tappets removed (see paragraph 3-14).
- Fuel metering pump removed (see paragraph 5-2).

Materials/Parts:

- Engine oil (Item 25, Appendix B)
- Rags (Item 28, Appendix B)
- Dry cleaning solvent (Item 31, Appendix B)
- Dry cleaning solvent (Item 31, Appendix B)

Tools/Test Equipment

- General mechanic's tool kit
- Field automotive shop set

Personnel Required: Two**General Safety Instructions:**

- Dry cleaning solvent is flammable and must not be used near open flame. Use only in a well-ventilated area.

a. VALVE LIFT CHECK**NOTE**

Measuring valve lift is the same for all valves except where noted. One valve is shown. Repeat procedure for other valves.

1. Using dial indicator, measure lift of valve cap (1) while assistant manually cranks engine assembly. Valve lift must be 0.456-0.482 in. (11.582-12.243 mm) for exhaust valve and 0.460-0.490 in. (11.684-12.446 mm) for intake valve.

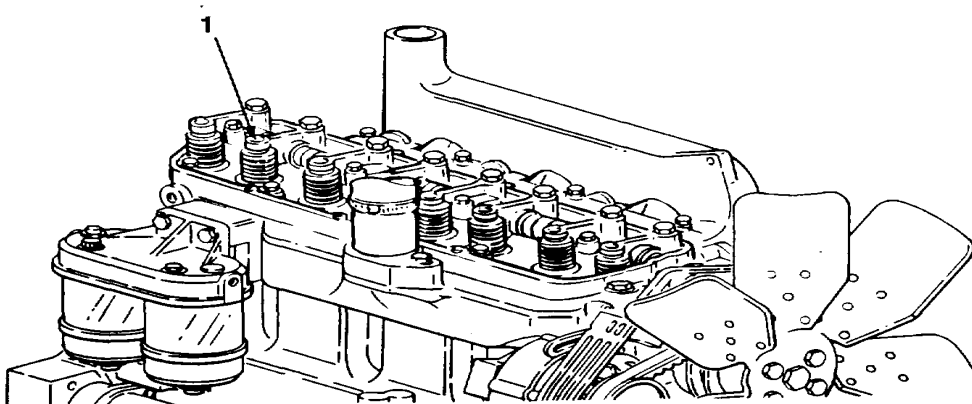

3-17. CAMSHAFT MAINTENANCE (Con't).

2. If measurement is not within specification, inspect valves (see paragraph 3-12), rocker arms, rocker arm shaft, and pushrods (see paragraph 3-13), and tappets (see paragraph 3-14).

b. REMOVAL**CAUTION**

To avoid damage to pistons and valves, do not crank engine assembly with any timing components removed.

1. Pry helical gear (4) away from thrust plate (6) as far as possible. Using dial indicator, measure end play. End play must be 0.0025-0.0235 in. (0.0635-0.5969 mm).
2. Rotate helical gear (4) and camshaft (3) until two screws (5) are accessible. Remove two screws and thrust plate (6) from engine block (2).

CAUTION

Do not knock camshaft against engine block bores when removing camshaft. This may damage parts.

3. Pull camshaft (3) with assembled parts out of engine block (2).

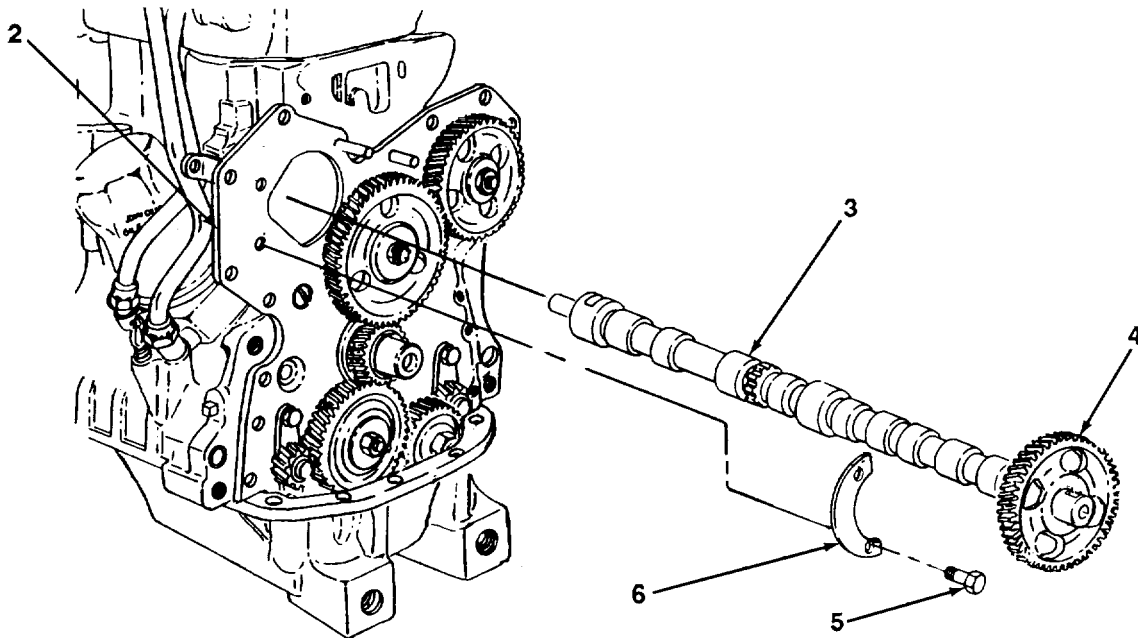

TA701286

3-17. CAMSHAFT MAINTENANCE (Con't).**c. DISASSEMBLY****CAUTION**

Do not remove tachometer shaft from camshaft unless damaged. Removal may damage parts.

1. Using plier wrench and pry bar, pry tachometer shaft (7) out of camshaft (3).
2. Using 1/ in. remover and installer and arbor press, press camshaft (3) and assembled parts out of helical gear (4).
3. Remove Woodruff key (8) from camshaft (3)

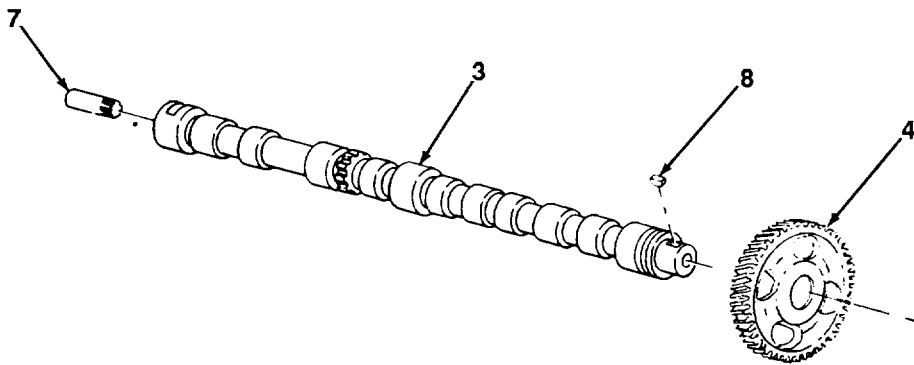
**d. CLEANING AND INSPECTION****WARNING**

Dry cleaning solvent, P-D-680, is toxic and flammable. Always wear protective goggles and gloves, and use only in a well-ventilated area. Avoid contact with skin, eyes, and clothes, and DO NOT breathe vapors. DO NOT use near open flame or excessive heat. The solvent's flash point is 100°F-138°F (38°C-59°C). If you become dizzy while using cleaning solvent, immediately get fresh air and medical help. If solvent contacts eyes, immediately wash your eyes and get medical aid.

1. Clean all metal parts with dry cleaning solvent. Dry thoroughly with clean rags.
2. Inspect all metal parts for cracks, bends, and breaks. Replace defective parts as required.

TA701287

3-17. CAMSHAFT MAINTENANCE (Con't).

NOTE

If camshaft needs replacing, tappets must also be replaced.

3. Inspect camshaft for scoring and excessive wear. Using micrometer caliper set, measure diameter of camshaft journals. Diameter must be 2.1987-2.2007 in. (55.8470-55.8978 mm).
4. Using vernier caliper, measure thickness of thrust plate. Thickness must be 0.1510-0.1580 in. (3.8354-4.0132 mm). If end play measurement taken in step 1 of removal or thickness measurement taken in this step are not within specifications, replace thrust plate.
5. Inspect helical gear for nicks, burrs, and damaged teeth. Remove burrs with sharpening stone. If gear is nicked or teeth are damaged, replace.

e. ASSEMBLY

1. Tap woodruff key (8) in position in camshaft (3).
2. Support camshaft (3) with a wood block under forward journal. With the aid of an assistant, use a wood block and ball-peen hammer to tap on helical gear (4) until seated against camshaft flange.

NOTE

Perform step 3 only if tachometer shaft was removed.

3. Using remover and installer and arbor press, press tachometer shaft (7) in camshaft (3). Ensure that slot faces opposite direction of woodruff key (8).

3-17. CAMSHAFT MAINTENANCE (Con't).**f. INSTALLATION****CAUTION**

Do not knock camshaft against engine block bores when installing camshaft. This may damage parts.

1. Lubricate camshaft (3) and assembled parts with engine oil. Slide camshaft with assembled parts into engine block (2).
2. Install thrust plate (6) in place around camshaft (3) and on engine block (2). Rotate helical gear (4) until screw holes in engine block and thrust plate are aligned.
3. Install two screws (5) in thrust plate (6) and engine block (2). Torque screws to 35 lb.-ft. (47 N•m).

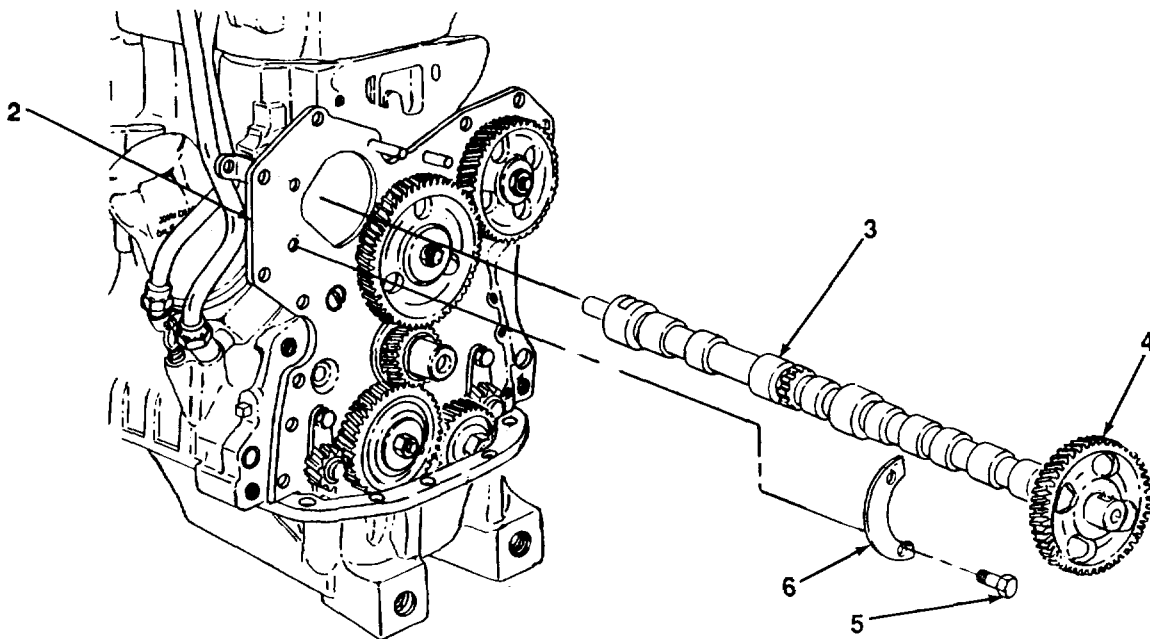
**FOLLOW-ON TASKS:****NOTE**

Perform the following if removal, disassembly, cleaning and inspection, assembly, and installation were required.

- Install fuel metering pump (see paragraph 5-2).
- Install tappets (see paragraph 3-14).
- Install upper idler spur gear (see paragraph 3-15).

NOTE

Perform the following after performing valve lift check.

- Install rocker arm cover (see TM 5-2420-222-20).

TA701288

3-18. TIMING GEAR COVER MAINTENANCE.

This Task Covers:

- | | |
|----------------------------|-----------------|
| a. Removal | d. Assembly |
| b. Disassembly | e. Installation |
| c. Cleaning and Inspection | |
| d. | |
-

*Initial Setup:***Equipment Conditions:**

- Fan blade and pulley removed (see TM 5-2420-222-20).
- AC generator mounting brackets removed (see TM 5-2420-222-20).
- Oil filler neck removed (see TM 5-2420-222-20).
- Lubricating cooler-to-water pump coolant lines removed (see TM 5-2420-222-20).
- Water pump removed (see TM 5-2420-222-20).
- Crankshaft pulley removed (see TM 5-2420-222-20).
- Pressure regulating valve removed (see paragraph 3-22).

Tools/Test Equipment:

- General mechanic's tool kit
- Field automotive shop set

Materials/Parts:

- Sealing compound (Item 11, Appendix B)
- Grease (Item 22, Appendix B)
- Rags (Item 28, Appendix B)
- Dry cleaning solvent (Item 31, Appendix B)
- One seal
- Three gaskets
- Twenty-three lockwashers

Personnel Required: Two**General Safety Instructions:**

- Dry cleaning solvent is flammable and must not be used near open flame. Use only in a well-ventilated area.

3-18. TIMING GEAR COVER MAINTENANCE (Con't).

a. REMOVAL

NOTE

Note length and location of screws during removal to ensure proper installation.

1. Remove six screws (9) and lockwashers (8) from engine oil pan (10) and timing gear cover (11). Discard lockwashers.
2. Remove two screws (4) and lockwashers (7) from timing gear cover (11) and engine block (1). Discard lockwashers.

NOTE

Timing gear covers with large access covers have one longer screw through access cover and nine shorter screws securing timing gear cover. Timing gear covers without large access covers are secured with ten screws of the same length.

3. Remove ten screws (3) with lockwashers (2), or nine screws (3) with lockwashers (2), and screw (5) with lockwasher (6) from timing gear cover (11), cylinder block plate (12), engine block (1), and access cover (13). Discard lockwashers.

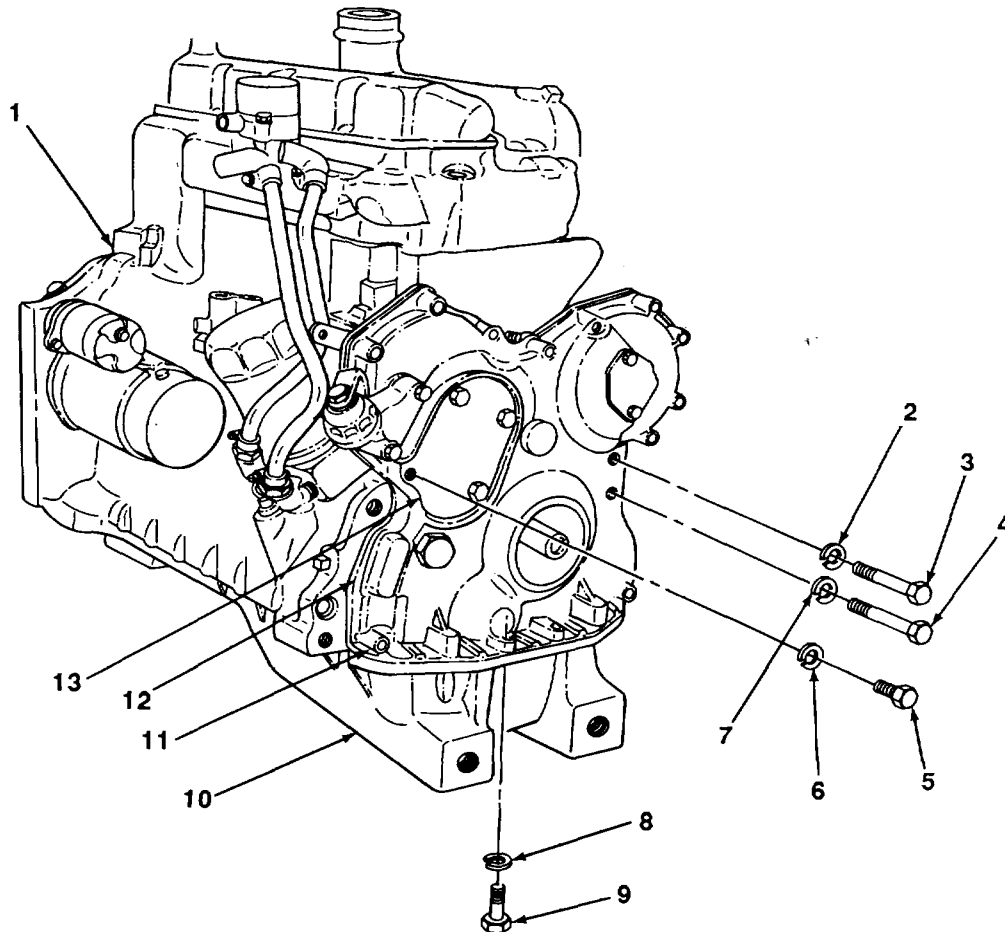

3-18. TIMING GEAR COVER MAINTENANCE (Con't).

4. Remove two nuts (15) from studs (24) and timing gear cover (11).
5. With the aid of an assistant, lift timing gear cover (11) and gasket (14) off engine block (1) and cylinder block PLATE (12). Discard gasket.

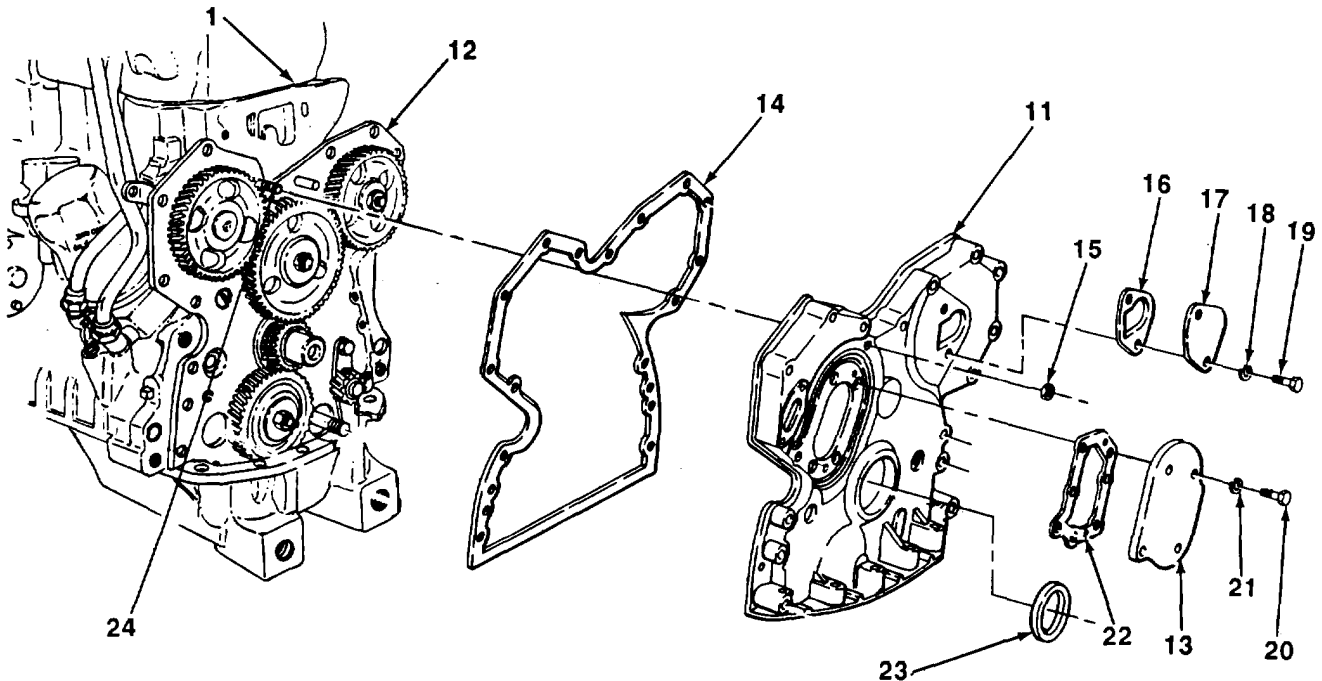
**b. DISASSEMBLY****NOTE**

Note length and location of screws during disassembly to ensure proper assembly.

1. Remove two screws (19) and lockwashers (18) from access cover (17) and timing gear cover (11). Discard lockwashers.
2. Remove access cover (17) and gasket (16) from timing gear cover (11). Discard gasket.
3. Remove three screws (20) and lockwashers (21) from access cover (13) and timing gear cover (11). Discard lockwashers.
4. Remove access cover (13) and gasket (22) from timing gear cover (11). Discard gasket.

CAUTION

When removing seal, do not pry or press against timing gear cover with excessive force. Timing gear cover is made of aluminum and excessive force may damage it.

5. Using drift and hammer, drive seal (23) out of timing gear cover (11). Discard seal.

TA701290

3-18. TIMING GEAR COVER MAINTENANCE (Con't).

c. CLEANING AND INSPECTION**WARNING**

Dry cleaning solvent, P-D-680, is toxic and flammable. Always wear protective goggles and gloves, and use only in a well-ventilated area. Avoid contact with skin, eyes, and clothes, and DO NOT breathe vapors. DO NOT use near open flame or excessive heat. The solvent's flash point is 100°F-138°F (38°C-59°C). If you become dizzy while using cleaning solvent, immediately get fresh air and medical help. If solvent contacts eyes, immediately wash your eyes and get medical aid.

1. Clean access covers and timing gear cover with dry cleaning solvent and rags. Dry thoroughly with clean, dry rags.
2. Inspect access covers and timing gear cover for cracks, breaks, abnormal bends, or damaged threads. Replace defective parts.
3. Restore damaged threads using screw threading set.

d. ASSEMBLY**CAUTION**

When installing seal, do not press against timing gear cover with excessive force. Timing gear cover is made of aluminum and excessive force may damage it.

1. Support seal bore area of timing gear cover (11) with wood blocks.
2. Coat outside edge of new seal (23) with sealing compound. Position seal in seal bore of timing gear cover (11) with spring-loaded lip facing rearward.
3. Using remover and installer and hammer, tap seal (23) in place in timing gear cover (11).
4. Position access cover (13) and new gasket (22) in place on timing gear cover (11). Install three screws (20) and new lockwashers (21) in access cover and timing gear cover.
5. Position access cover (17) and new gasket (16) in place on timing gear cover (11). Install two screws (19) and new lockwashers (18) in access cover and timing gear cover.

3-18. TIMING GEAR COVER MAINTENANCE (Con't).

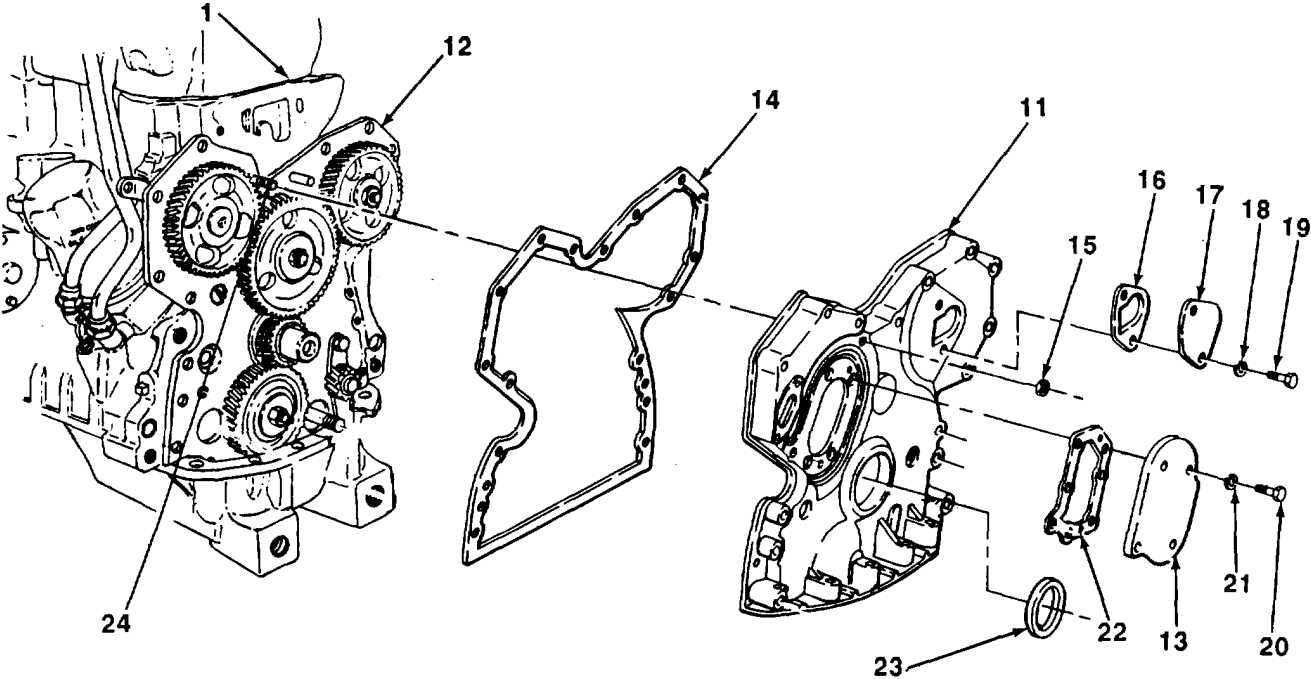

e. INSTALLATION

1. Lubricate spring-loaded lip of seal (23) with grease.
2. With the aid of an assistant, position timing gear cover (11) and new gasket (14) in place on engine block (1) and cylinder block plate (12). Ensure that seal lips do not turn in.
3. Install two nuts (15) on studs (24).

TA701291

3-18. TIMING GEAR COVER MAINTENANCE (Con't).

- 4. Install ten screws (3) with lockwashers (2), or nine screws (3) with lockwashers (2), and screw (5) with lockwasher (6) in timing gear cover (11), access cover (13), engine block (1), and cylinder block plate (12).
- 5. Install two screws (4) and new lockwashers (7) in timing gear cover (11) and engine block (1). Torque screws to 35 lb.-ft. (47 N•m).
- 6. Install six screws (9) and new lockwashers (8) in timing gear cover (11) and engine oil pan (10). Torque screws to 35 lb.-ft. (47•N.m).
- 7. Torque ten screws (3) or nine screws (3) and screw (5) to 35 lb.-ft (47 N•m).

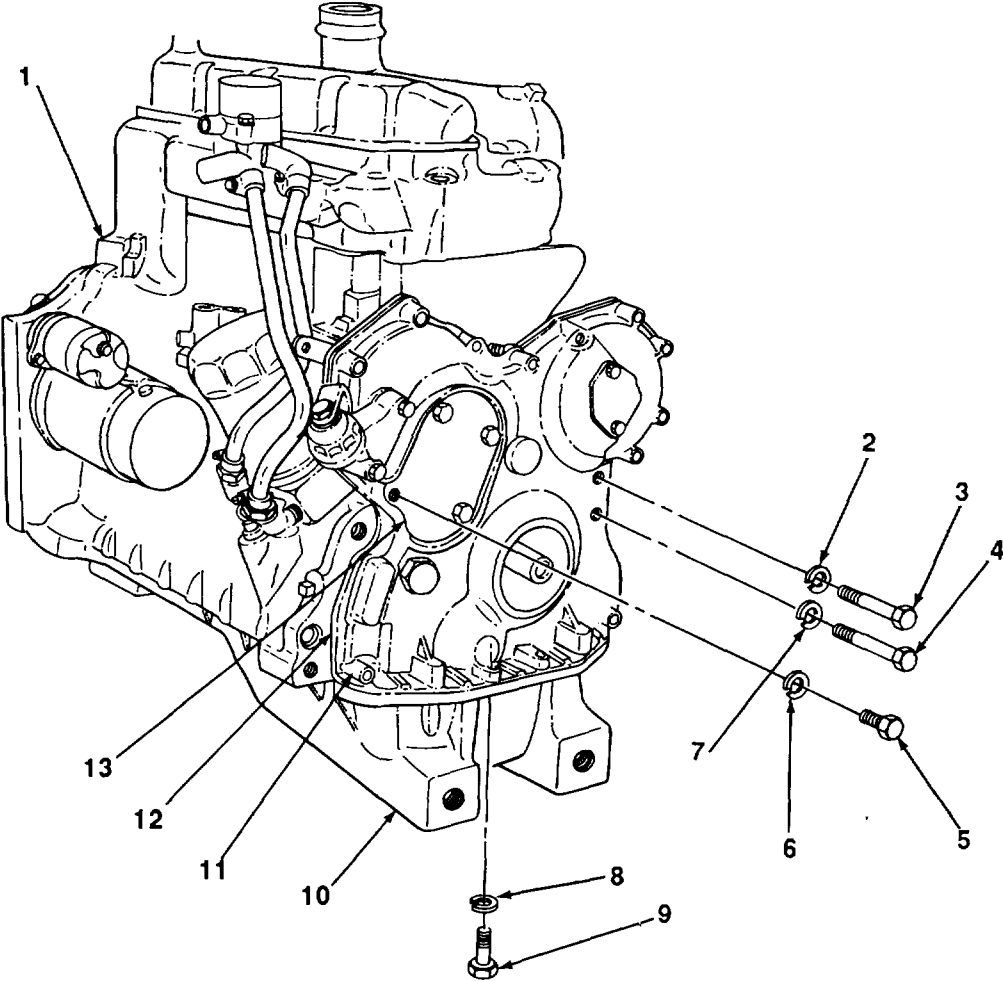

3-18. TIMING GEAR COVER MAINTENANCE (Con't).

FOLLOW-ON TASKS:

- Install pressure regulating valve (see paragraph 3-22).
- Install crankshaft pulley (see TM 5-2420-222-20).
- Install water pump (see TM 5-2420-222-20).
- Install lubricating cooler-to-water pump coolant lines (see TM 5-2420-222-20).
- Install oil filler neck (see TM 5-2420-222-20).
- Install AC generator mounting brackets (see TM 5-2420-222-20).
- Install fan blade and pulley (see TM 5-2420-222-20).

3-19. CONTROL CAMS, GEARS, AND BUSHINGS REPLACEMENT.

This Task Covers:

- | | |
|----------------------------|-----------------|
| a. Removal | d. Assembly |
| b. Disassembly | e. Installation |
| c. Cleaning and Inspection | |
-

Initial Setup:

Equipment Conditions:

- Engine oil pan removed (see paragraph 3-20).
- Lower idler spur gear removed (see paragraph 3-15).

Tools/Test Equipment:

- General mechanic's tool kit
- Field automotive shop set
- Bearing remover and installer
- Timing alignment tool

Materials/Parts:

- Engine oil (Item 25, Appendix B)
- Rags (Item 28, Appendix B)
- Dry cleaning solvent (Item 31, Appendix B)
- One jamnut
- Two lockwashers

General Safety Instructions:

- Dry cleaning solvent is flammable and must not be used near open flame. Use only in a well-ventilated area.
-

NOTE

Loader backhoe engine has two control cams. Maintenance is the same for both, except where noted. Right control cam is shown. Repeat procedure for left control cam as required.

a. REMOVAL

NOTE

Perform step 1 only when removing left control cam.

1. Remove Jamnut (4) and engine oil pump spur gear (3) from engine oil pump drive shaft (2). Discard jamnut.
2. Pry control cam spur gear (8) away from thrust plate (5) as far as possible.
3. Using dial Indicator, measure end play of control cam spur gear (8). End play must be 0.0020-0.0230 In. (0.0508-0.5842 mm).
4. Remove two screws (7) and lockwashers (6) from thrust plate (5) and engine block (1). Slide thrust plate out of engine block. Discard lockwashers.
5. Pull control cam spur gear (8) and control cam (9) out of engine block (1).

3-19. CONTROL CAMS, GEARS, AND BUSHINGS REPLACEMENT (Con't).

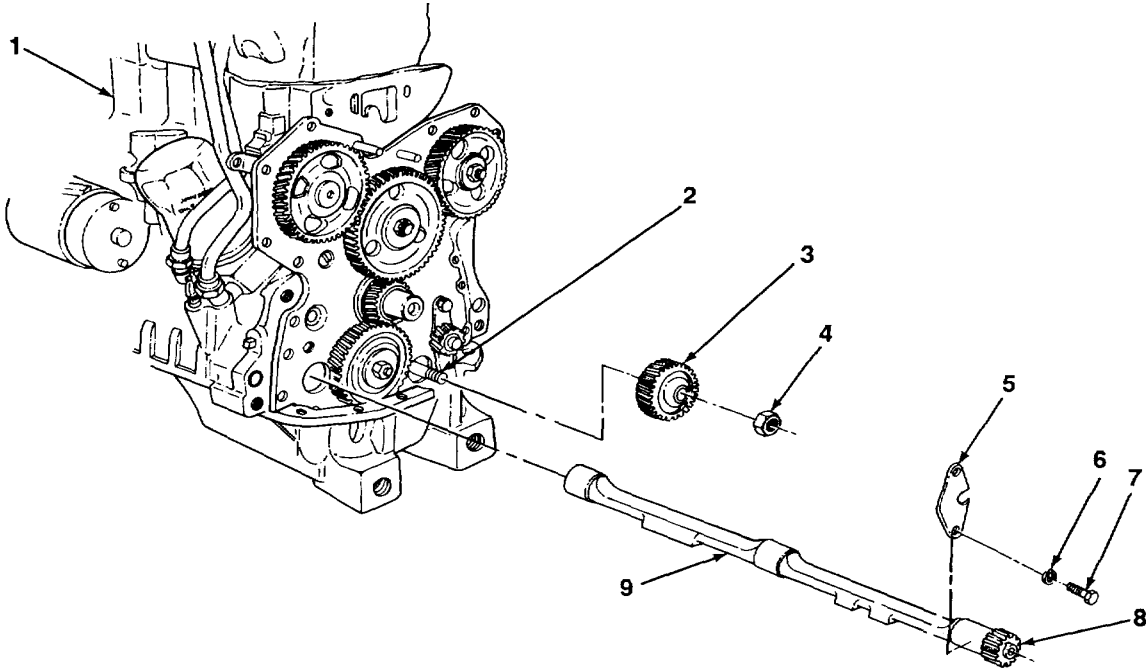

CAUTION

Do not remove bushings unless damaged. Removal may damage parts.

- 6. Using bearing remover and installer, remove two bushings (12 and 13) from engine block (1).

NOTE

Perform steps 7 and 8 only if engine assembly is installed and rear bushing is damaged.

- 7. Remove engine assembly (see paragraph 3-3).
- 8. Using bearing remover and installer, remove rear bushing (11) from engine block (1).

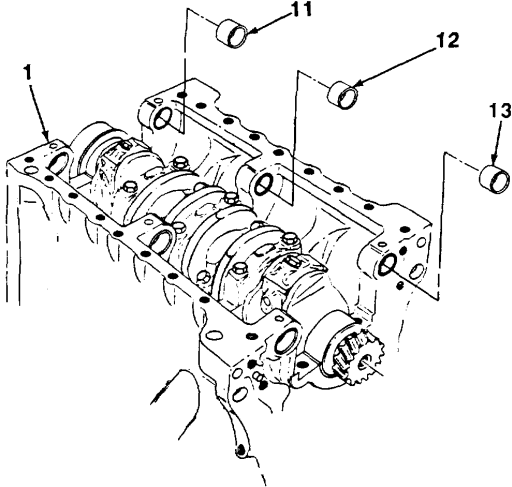

3-19. CONTROL CAMS, GEARS, AND BUSHINGS REPLACEMENT (Con't).**b. DISASSEMBLY**

1. Using gear and bearing mechanical puller kit, remove control cam spur gear (8) from control cam (9) and woodruff key (14).
2. Remove woodruff key (14) from control cam (9).

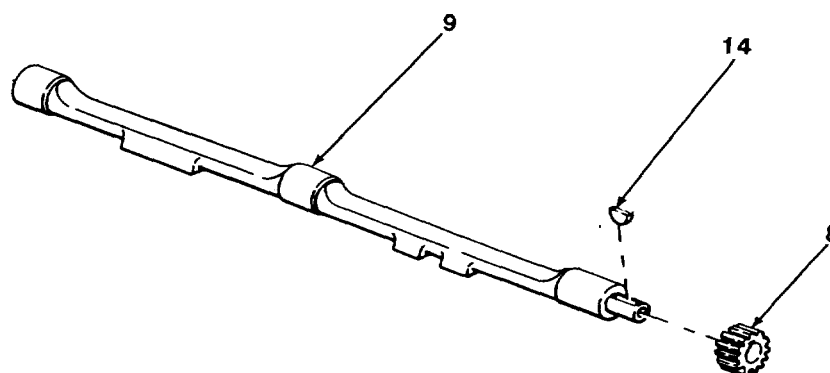
**c. CLEANING AND INSPECTION****WARNING**

Dry cleaning solvent, P-D-680, is toxic and flammable. Always wear protective goggles and gloves, and use only in a well-ventilated area. Avoid contact with skin, eyes, and clothes, and DO NOT breathe vapors. DO NOT use near open flame or excessive heat. The solvent's flash point is 100°F-138°F (38°C-59°C). If you become dizzy while using cleaning solvent, immediately get fresh air and medical help. If solvent contacts eyes, immediately wash your eyes and get medical aid.

1. Clean all metal parts with dry cleaning solvent and rags. Dry thoroughly with clean, dry rags.
2. Inspect control cam and three bushings for cracks, breaks, and abnormal wear.
3. Using vernier caliper, measure inside diameter of bushings at several locations. Inside diameter must be 1.502-1.504 in. (38.151-38.202 mm).
4. Using micrometer caliper, measure outside diameter of three control cam journals at several locations. Outside diameter must be 1.4995-1.5005 in. (38.0873-38.1127 mm).
5. Subtract smallest measurement taken in step 4 from largest measurement taken in step 3 to determine bushing-to-journal clearance. Clearance must be 0.0015-0.0105 in. (0.0381-0.2667 mm).
6. Inspect thrust plate for cracks, bends, and breaks. Using vernier caliper, measure thickness of thrust plate. Thickness must be 0.117-0.124 in. (2.972-3.150 mm).

TA701294

3-19. CONTROL CAMS, GEARS, AND BUSHINGS REPLACEMENT (Con't).

7. Inspect control cam spur gear for cracks, bends, burrs, and damaged teeth. Remove burrs with sharpening stone.
8. Inspect all other metal parts for cracks, bends, breaks, and damaged threads. Restore damaged threads using screw threading set.

d. ASSEMBLY

1. Tap woodruff key (14) into position on control cam (9).
2. Tap control cam spur gear (8), with timing slash-mark facing away, on control cam (9). Using micrometer depth gage, measure distance control cam spur gear is out of flush with control cam. Distance must not exceed 0.0010 in. (0.0254 mm).

e. INSTALLATION**NOTE**

Perform steps 1 and 2 only if rear bushing was removed.

1. Using bearing remover and installer, install rear bushing (11) from front to rear, ensuring that oil holes are aligned. Lubricate inner surface of rear bushing with engine oil.
2. Install engine assembly (see paragraph 3-3).

NOTE

Perform step 3 only if bushings were removed.

3. Using bearing remover and installer, install two bushings (12 and 13) from front to rear, ensuring that oil holes are aligned. Lubricate inner surface of bushings with engine oil.

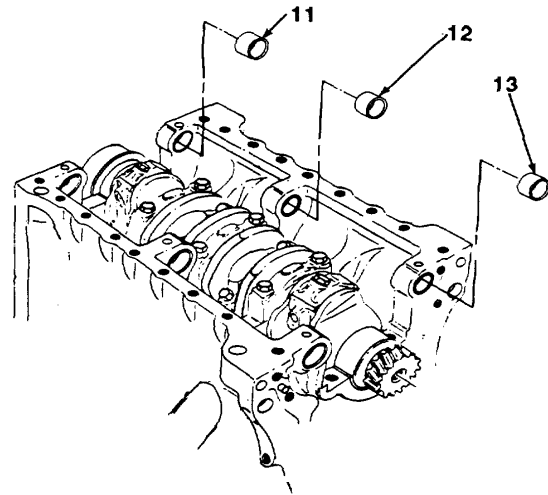

TA701295

3-19. CONTROL CAMS, GEARS, AND BUSHINGS REPLACEMENT (Con't).

4. Lubricate control cam journals with engine oil. Slide control cam (9) with assembled parts into engine block (1).
5. Position thrust plate (5) in place on engine block (1). Install two screws (7) and new lockwashers (6) in thrust plate and engine block. Torque screws to 35 lb.-ft. (47 N•m).
6. Rotate control cam spur gear (8) until timing slash-mark is alined with center of crankshaft (10). Using timing alinement tool, ensure that timing slash-mark is alined with center of crankshaft.

NOTE

Perform steps 7 and 8 only if left control cam was removed.

7. Position engine oil pump spur gear (3) in place on engine oil pump drive shaft (2) with timing slash-mark alined with center of crankshaft (10). Using timing alinement tool, ensure that timing slash-mark is alined with center of crankshaft.
8. Install new jamnut (4) on engine oil pump drive shaft (2) and engine oil pump spur gear (3). Torque jamnut to 35-45LB.-FT. (47-61 N•m). Stake jamnut to drive shaft.

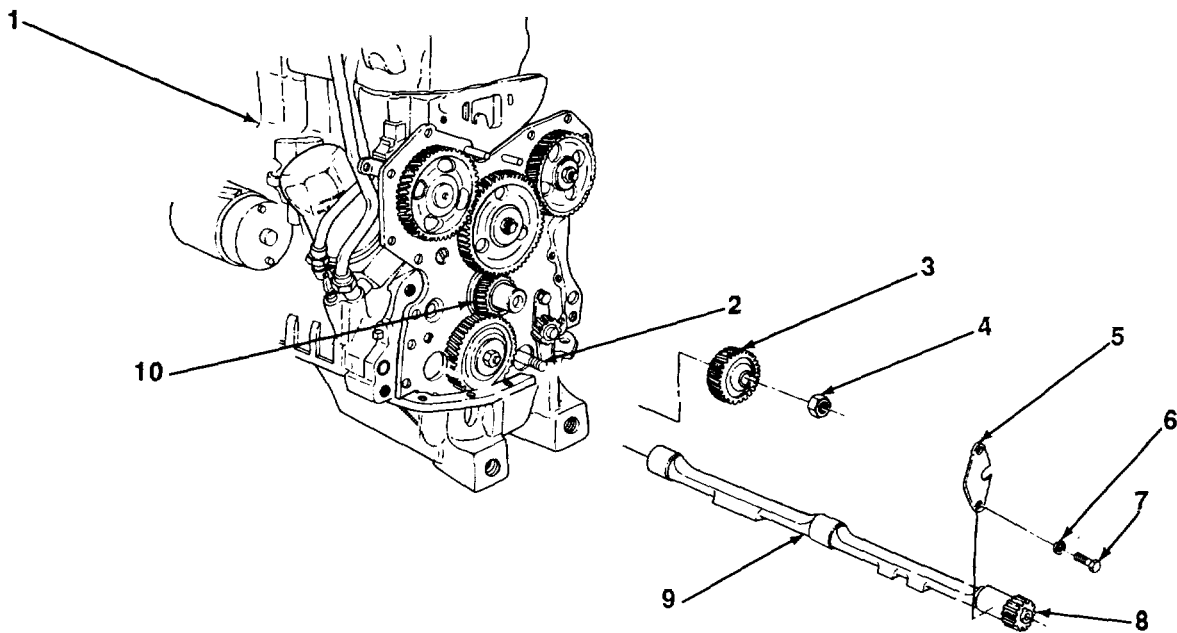
**FOLLOW-ON TASKS:**

- Install lower idler spur gear (see paragraph 3-15).
- Time engine (see paragraph 3-16).
- Install engine oil pan (see paragraph 3-20).

Section II. LUBRICATION SYSTEM MAINTENANCE

Paragraph Number	Paragraph Title	Page Number
3-20	Engine Oil Pan Replacement	3-115
3-21	Engine Oil Pump Maintenance.....	3-120
3-22	Pressure Regulating Valve Replacement	3-125

3-20. ENGINE OIL PAN REPLACEMENT.

This Task Covers:

- | | |
|--|---|
| <ul style="list-style-type: none"> a. Removal b. Cleaning and Inspection | <ul style="list-style-type: none"> c. Installation |
|--|---|
-

Initial Setup:

Equipment Conditions:

- Engine oil drained (see TM 5-2420-222-20).

Tools/Test equipment:

- General mechanic's tool kit
- Field automotive shop set

Materials/Parts:

- Sealing compound (Item 11, Appendix B)
- Rags (Item 28, Appendix B)
- Dry cleaning solvent (Item 31, Appendix B)
- One gasket
- Thirty-two lockwashers

Personnel Required: Two

General Safety Instructions:

- Dry cleaning solvent is flammable and must not be used near open flame. Use only in a well-ventilated area.
-

3-20. ENGINE OIL PAN REPLACEMENT (Con't).**a. REMOVAL**

1. Remove two screws (3) and lockwashers (4) from oil pan (22) and frame assembly front support (2). Discard lockwashers.
2. Remove two screws (14) and lockwashers (15) from oil pan (22), flywheel housing (26), and reverser housing (1). Discard lockwashers.

WARNING

Use extreme caution when handling heavy parts. Lifting device is required when parts weigh over 50 lb (23 kg) for a single person lift, over 100 lb (45 kg) for a two person lift, and over 150 lb (68 kg) for a three or more person lift. Keep clear of heavy parts supported only by lifting device. Failure to follow this warning may cause serious injury or death to personnel.

3. Using hydraulic jack, support oil pan (22) in place on engine block (25) and timing gear cover (24).

NOTE

Screws securing oil pan have different lengths and hardness. Note location of screws during removal to ensure proper placement during installation.

4. Remove six screws (9) and lockwashers (5) from oil pan (22) and timing gear cover (24). Discard lockwashers.
5. Remove 22 screws (6, 10, 11, 16, 17, 18, 20, and 21) and lockwashers (5 and 19) from oil pan (22) and engine block (25). Discard lockwashers.
6. Tap oil pan (22) with hammer to unseat. With the aid of an assistant and hydraulic jack, lower oil pan and gasket (23) from engine block (25) and timing gear cover (24). Discard gasket.
7. Pry spacers (7 and 8) from oil pan (22). Note quantity and location of spacers to ensure proper installation.
8. Remove plug (13) and spring tension washer (12) from oil pan (22).

b. CLEANING AND INSPECTION**WARNING**

Dry cleaning solvent, P-D-680, is toxic and flammable. Always wear protective goggles and gloves, and use only in a well-ventilated area. Avoid contact with skin, eyes, and clothes, and DO NOT breathe vapors. DO NOT use near open flame or excessive heat. The solvent's flash point is 100°F-138°F (38°C-59°C). If you become dizzy while using cleaning solvent, immediately get fresh air and medical help. If solvent contacts eyes, immediately wash your eyes and get medical aid.

1. Clean oil pan and plug with dry cleaning solvent and clean rags. Dry thoroughly with clean, dry rags.
2. Inspect oil pan for cracks, breaks, and abnormal bends. Replace if defective.
3. Inspect oil pan and plug for damaged threads. Restore damaged threads using screw threading set.

c. INSTALLATION

1. Install spring tension washer (12) and plug (13) in oil pan (22).

3-20. ENGINE OIL PAN REPLACEMENT (Con't).

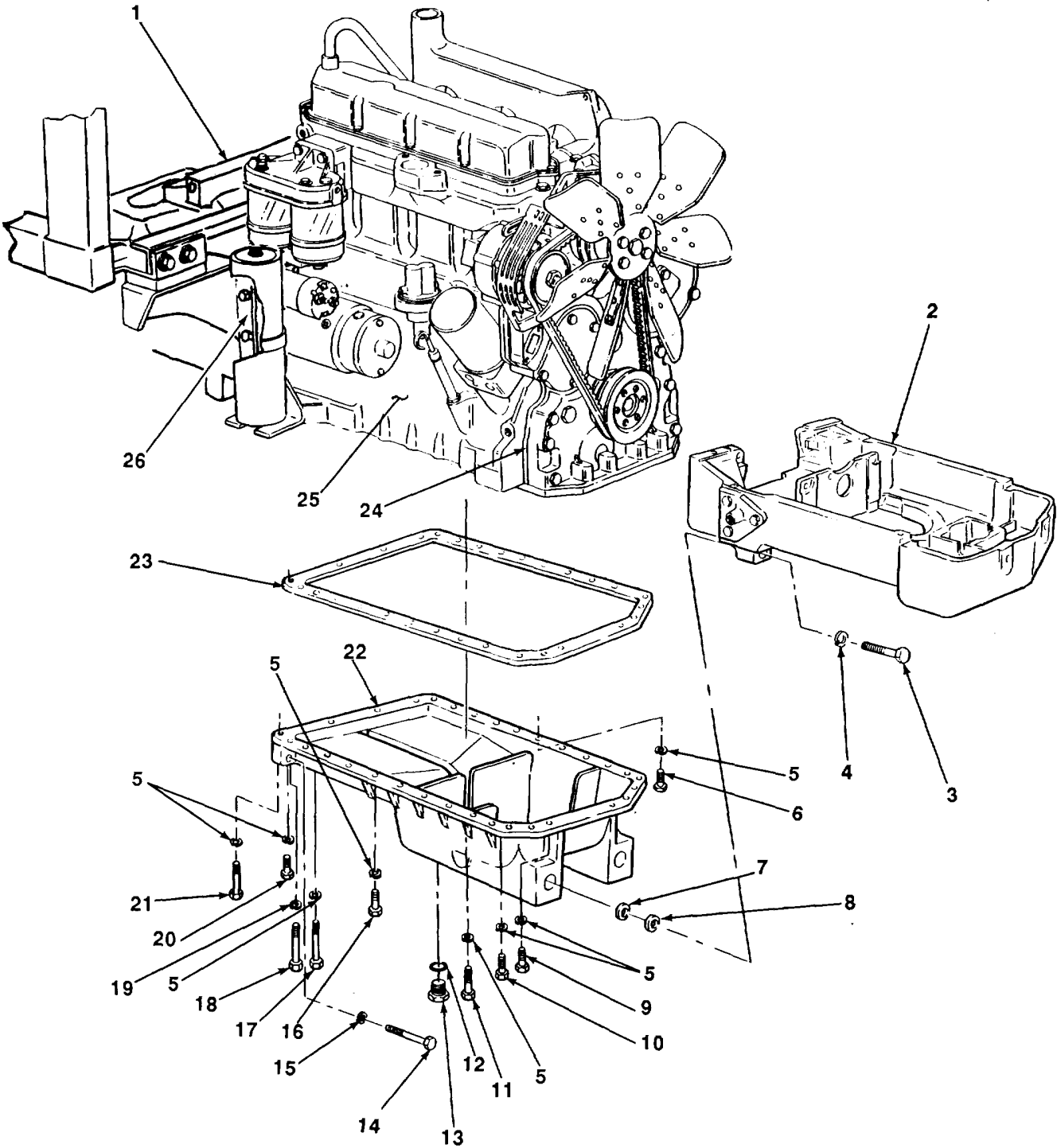

TA701297

3-20. ENGINE OIL PAN REPLACEMENT (Con't).

WARNING

Use extreme caution when handling heavy parts. Lifting device is required when parts weigh over 50 lb (23 kg) for a single person lift, over 100 lb (45 kg) for a two person lift, and over 150 lb (68 kg) for a three or more person lift. Keep clear of heavy parts supported only by lifting device. Failure to follow this warning may cause serious injury or death to personnel.

2. With the aid of an assistant and hydraulic jack, position oil pan (22) and new gasket (23) in place under engine block (25) and against timing gear cover (26).
3. Loosely install 22 screws (6, 10, 11, 16, 17, 18, 20, and 21) and new lockwashers (5 and 19) in oil pan (22) and engine block (25).
4. Install six screws (9) and new lockwashers (5) in oil pan (22) and timing gear cover (24). Torque screws to 35 lb.-ft. (47 N•m).

NOTE

Screws securing oil pan have different lengths and hardness. Screws with three slash-marks must be torqued to 35 lb.-ft. (47 N•m). Screws with six slash-marks must be torqued to 50 lb.-ft. (68 N•m).

5. Tighten 22 screws (6, 10, 11, 16, 17, 18, 20, and 21) until snug. Torque four screws (18 and 20) to 35 lb.-ft. (47 N•m).
6. Torque 18 screws (6, 10, 11, 16, 17, and 21) to 50 lb.-ft. (68 N•m).
7. Install two screws (14) and new lockwashers (15) in oil pan (22), flywheel housing (26), and reverser housing (1). Torque screws to 250 lb.-ft. (339 N•m).

NOTE

There are spacers on both sides of oil pan. Installation and clearance measurements are the same for both sides. Right side is shown. Repeat steps 8 through 10 for left side.

8. Position spacers (7 and 8) in place against oil pan (22) and frame assembly front support (2).
9. Using thickness gage, measure clearance between spacers (7 and 8) and frame assembly front support (2). Clearance must be 0.000-0.001 in. (0.000-0.025 mm).

CAUTION

Ensure that mating surfaces of oil pan, spacers, and frame assembly front support have been properly cleaned before sealing compound is applied. Dirty surfaces may prevent sealing compound from sticking causing improper fit and damage to parts. Ensure that no sealing compound gets in screw holes. This will cause false torque readings which may damage parts.

10. If clearance exceeds specification, add one spacer (7 or 8) and repeat steps 7 and 8. If clearance satisfies specification, apply thread sealing compound to spacers and place back in position.
11. Install two screws (3) and new lockwashers (4) in frame assembly front support (2) and oil pan (22). Torque screws to 300 lb.-ft. (407 N•m).

3-20. ENGINE OIL PAN REPLACEMENT (Con't).

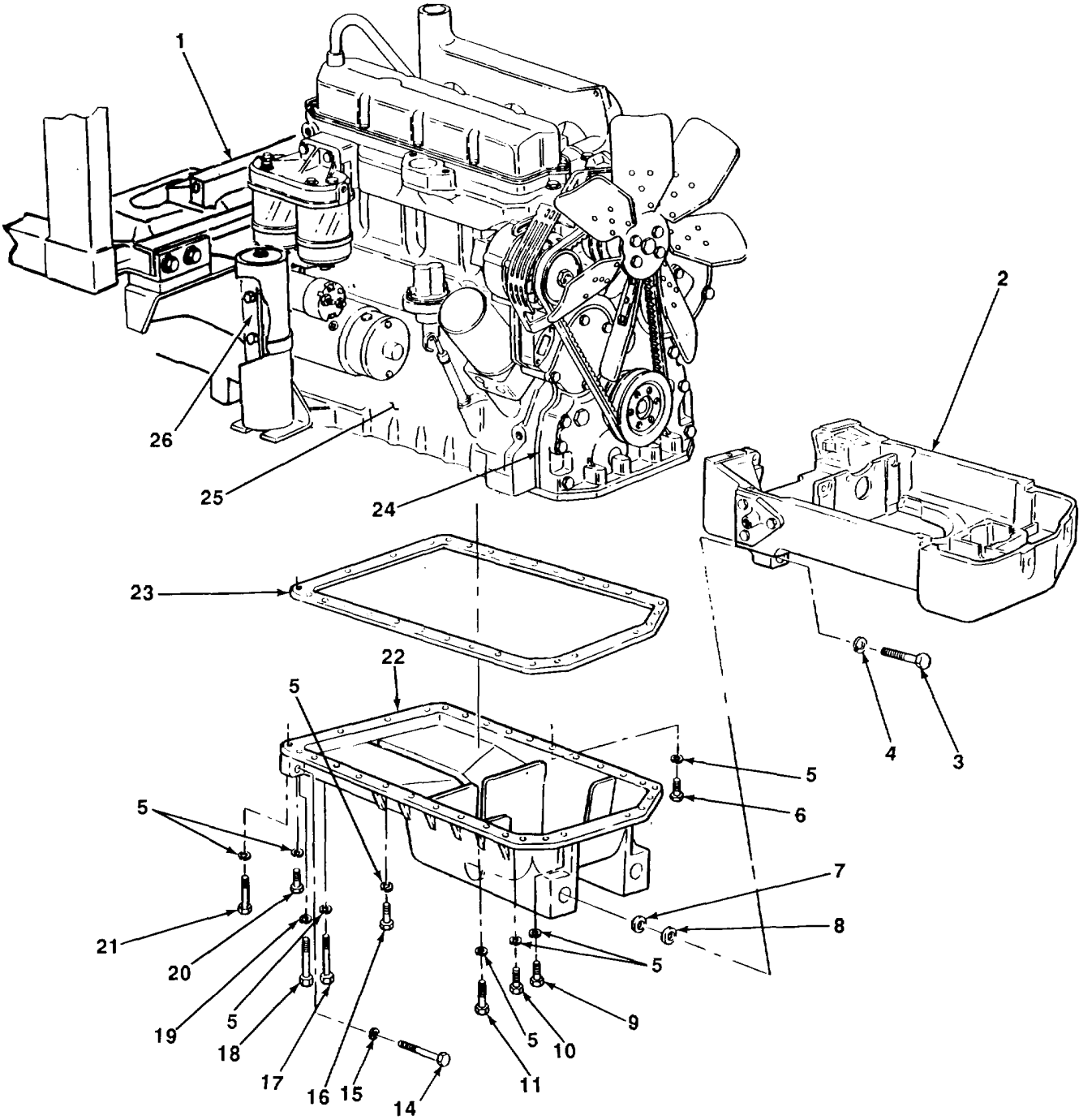

FOLLOW-ON TASKS:

- FILL Engine (see LO 5-2420-222-12).

3-21. ENGINE OIL PUMP MAINTENANCE.

This Task Covers:

- | | |
|----------------------------|-----------------|
| a. Removal | d. Assembly |
| b. Disassembly | e. Installation |
| c. Cleaning and Inspection | |
-

Initial Setup:

Equipment Conditions:

- Timing gear cover removed (see paragraph 3-18).
- Engine oil pan removed (see paragraph 3-20).

Tools/Test Equipment:

Tools/Test Equipment:

- General mechanic's tool kit
- Field automotive shop set
- Timing alinement tool

Materials/Parts:

- Engine oil (Item 25, Appendix B)
- Rags (Item 28, Appendix B)
- Dry cleaning solvent (Item 31, Appendix B)
- One jamnut
- Two preformed packings
- Four lockwasher

General Safety Instructions:

- Dry cleaning solvent is flammable and must not be used near open flame. Use only in a well-ventilated area.
-

a. REMOVAL

1. Wedge a clean rag between spur gear (4) and left control cam spur gear (3). Remove jamnut (5) from spur gear and drive shaft (6). Discard jamnut.
2. Pry spur gear (4) off drive shaft (6).

CAUTION

Be sure to hold oil pump while removing mounting hardware. Once hardware is removed, there is nothing to hold parts of pump together. Failure to hold pump will allow parts to fall and may cause damage.

NOTE

Screws lengths vary. Note length and location of screws to ensure proper installation.

3. Using machinist's scribe, match-mark two screws (11) and two screws (13) with oil pump assembly tube (12) and oil pump cover (8).
4. Remove two screws (11), two screws (13), and four lockwashers (10) from oil pump assembly tube (12), oil pump cover (8), oil pump housing (7), and cylinder block plate (1). Discard lockwashers.
5. Rotate oil pump cover (8) with attached oil outlet tube (9), oil pump assembly tube (12), and oil pump housing (7) until oil outlet tube clears engine block (2), then remove.
6. Remove oil pump assembly tube (12) and oil pump cover (8) from oil pump housing (7).

3-21. ENGINE OIL PUMP MAINTENANCE.

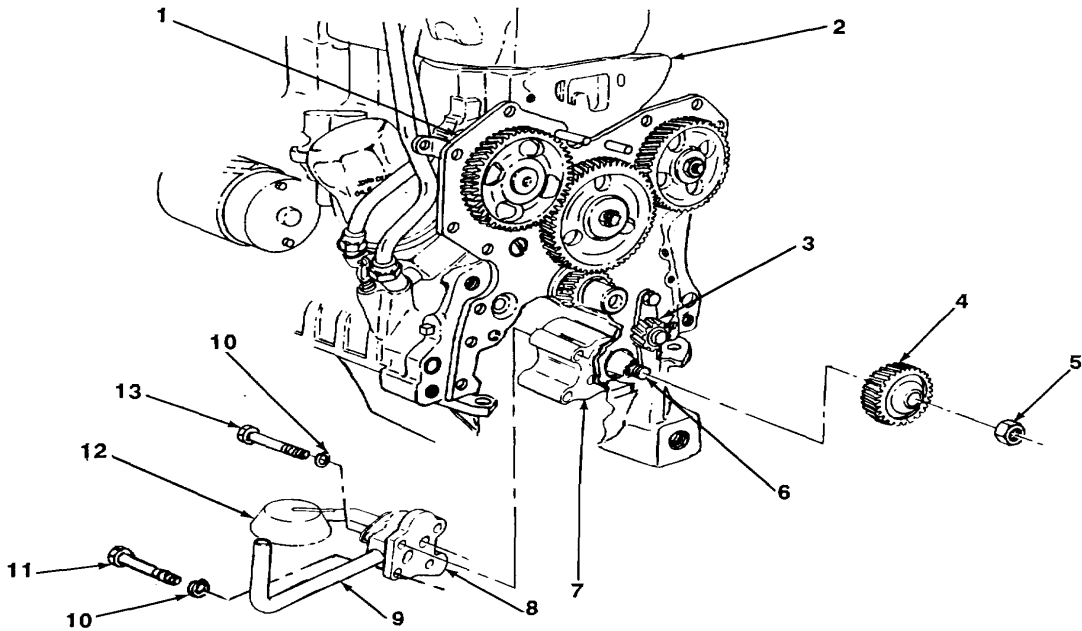

b. DISASSEMBLY

1. Remove preformed packing (15) from oil pump assembly tube (12). Discard preformed packing.
2. Remove oil outlet tube (9) from oil pump cover (8). Remove preformed packing (16) from oil pump cover. Discard preformed packing.

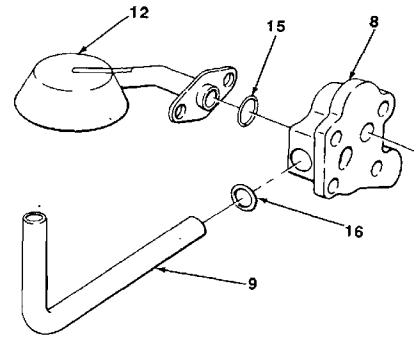

3-21. ENGINE OIL PUMP MAINTENANCE (Con't).**c. CLEANING AND INSPECTION****WARNING**

Dry cleaning solvent, P-D-680, is toxic and flammable. Always wear protective goggles and gloves, and use only in a well-ventilated area. Avoid contact with skin, eyes, and clothes, and DO NOT breathe vapors. DO NOT use near open flame or excessive heat. The solvent's flash point is 100°F-138°F (38°C-59°C). If you become dizzy while using cleaning solvent, immediately get fresh air and medical help. If solvent contacts eyes, immediately wash your eyes and get medical aid.

1. Clean oil pump cover, oil pump housing, oil outlet tube, spur gears, and oil pump assembly tube with dry cleaning solvent and clean rags. Dry parts thoroughly with clean, dry rags.
2. Inspect oil pump cover, oil pump housing, oil outlet tube, and oil pump assembly tube for cracks, bends, excessive wear damaged threads and warped mating surfaces. Restore damaged threads with screw threading set.
3. Inspect oil pump assembly tube for damaged screen.
4. Inspect spur gears (17 and 19) for cracks, breaks, chipped teeth, burrs, or excessive wear. Remove burrs with sharpening stone.
5. Using micrometer caliper set, measure outside diameter of drive shaft (6) at point where drive shaft wears against oil pump housing (7). Diameter must be 0.6308-0.6312 in. (16.0223-16.0325 mm). If not, replace oil pump.
6. Using micrometer caliper set, measure width of drive shaft spur gear (17) and spur gear (19). Width must be 1.6203-1.6223 in. (41.1556-41.2064 mm). If not, replace oil pump.
7. Using thickness gage, measure clearance between each spur gear tooth and oil pump housing (7). Clearance must be 0.0030-0.0060 in. (0.0762-0.1524 mm). If not, replace oil pump.
8. Place 6 in. machinist's rule across open face of oil pump housing (7). Using thickness gage, measure clearance between drive shaft spur gear (17), spur gear (19) and machinist's rule. Clearance must be 0.0012-0.0062 in. (0.0305-0.1575 mm). If not, replace oil pump.

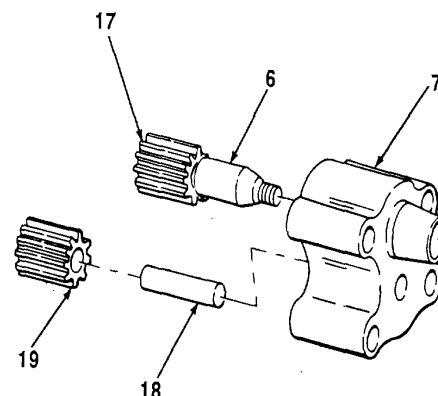
**d. ASSEMBLY**

1. Lubricate spur gear (19), straight shaft (18), drive shaft (6), and spur gear (17) with engine oil.

TA701300

3-21. ENGINE OIL PUMP MAINTENAI

2. Lubricate new preformed packing (16) with engine oil. Install preformed packing and oil outlet tube (9) in oil pump cover (8).
3. Lubricate new preformed packing (15) with engine oil. Install preformed packing on oil pump assembly tube (12).

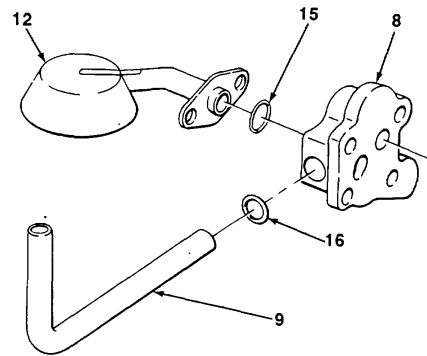
**e. INSTALLATION**

1. Using timing alinement tool, aline timing slash-mark on left control cam spur gear (3) with center of crankshaft (14).

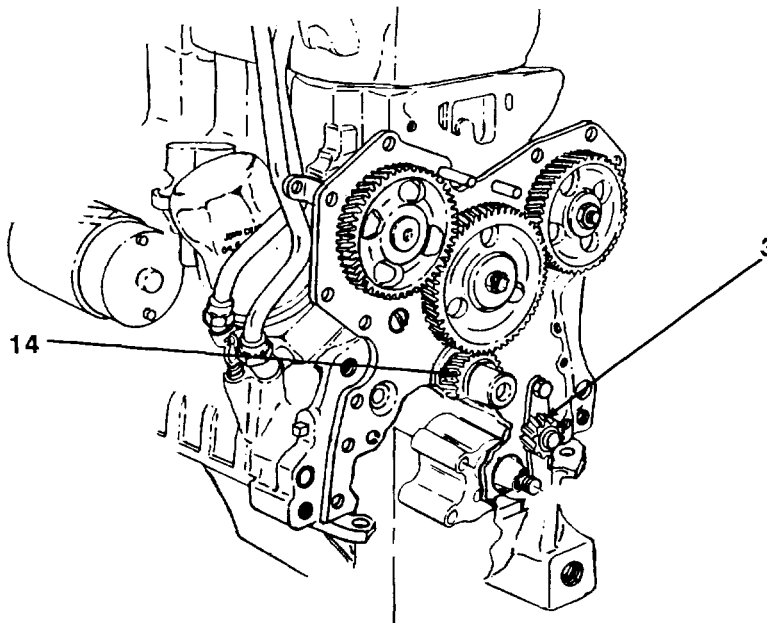

TA701301

3-21. ENGINE OIL PUMP MAINTENANCE (Con't).

2. Install oil pump housing (7) and assembled parts on cylinder block plate (1).
3. Position spur gear (4) on drive shaft (6) with timing slash-mark aligned with crankshaft (14). Tap spur gear onto drive shaft until seated.
4. Using timing alignment tool, ensure that timing slash-mark on spur gear (4) is aligned with crankshaft (14).
5. Wedge a clean rag between spur gear (4) and left control cam spur gear (3). Install jamnut (5) on spur gear (4) and drive shaft (6). Torque jamnut to 35-45 lb.-ft. (47-61 N•m). Stake jamnut to drive shaft. Remove rags.
6. Install oil pump cover (8) and oil pump assembly tube (12) on oil pump housing (7) with screw holes and match-marks aligned.
7. Install two screws (11), two screws (13), and four new lockwashers (10) in oil pump assembly tube (12), oil pump cover (8), oil pump housing (7), and cylinder block plate (1). Torque screws to 35lb.-ft. (47 N•m).

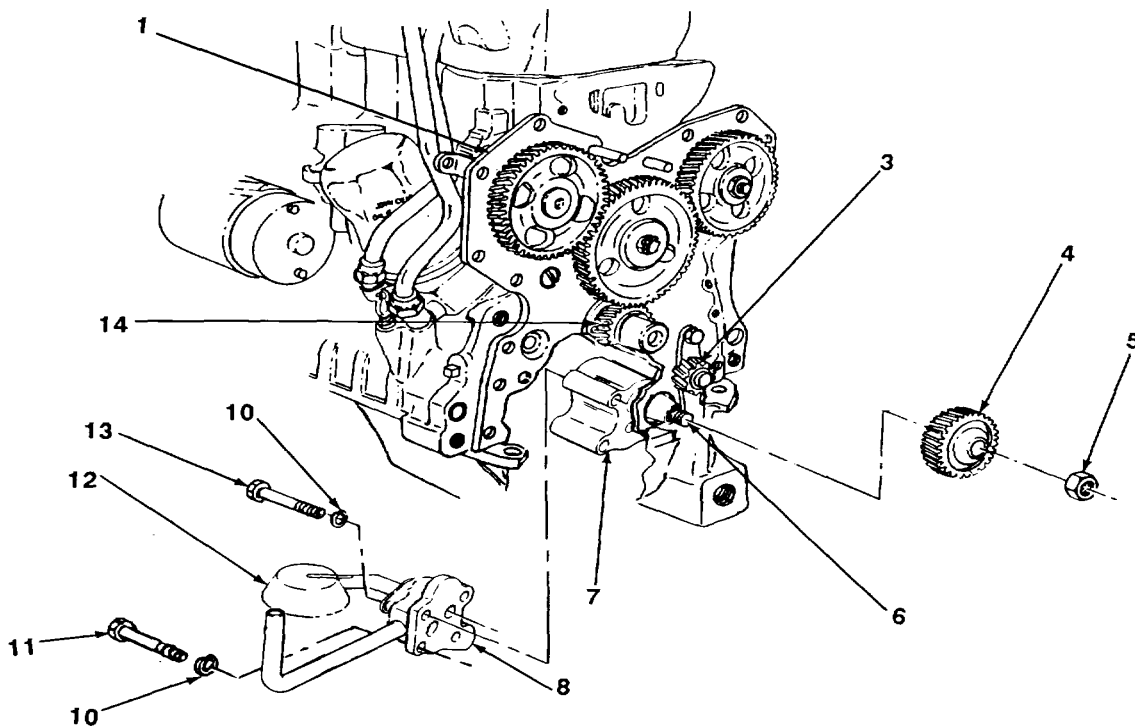
**FOLLOW-ON TASKS:**

- Install engine oil pan (see paragraph 3-20).
- Time engine (see paragraph 3-16).
- Install timing gear cover (see paragraph 3-18).

TA701302

3-22. PRESSURE REGULATING VALVE REPLACEMENT.

This Task Covers:

- | | |
|----------------------------|-----------------|
| a. Removal | c. Installation |
| b. Cleaning and Inspection | d. Adjustment |
-

Initial Setup:

Tools/Test Equipment:

- General mechanic's tool kit
- Field automotive shop set

Materials/Parts:

- Rags (Item 28, Appendix B)
- Dry cleaning solvent (Item 31, Appendix B)

References:

- TM 5-2420-222-10

NOTE**General Safety Instructions:**

- Dry cleaning solvent is flammable and must not be used near open flame. Use only in a well-ventilated area.

The following is used only if engine assembly is installed.

- Marker tags (Item 32, Appendix B)
-

a. REMOVAL

NOTE

Note quantity of washers to ensure proper installation.

3-22. PRESSURE REGULATING VALVE REPLACEMENT (Con't).

1. Remove machine plug (9) and washers (3 and 8) from timing gear cover (4).
2. Remove spring (6) from timing gear cover (4) and engine block (3).
3. Using magnetic retrieving tool, remove directional slide (5) from engine block (3).

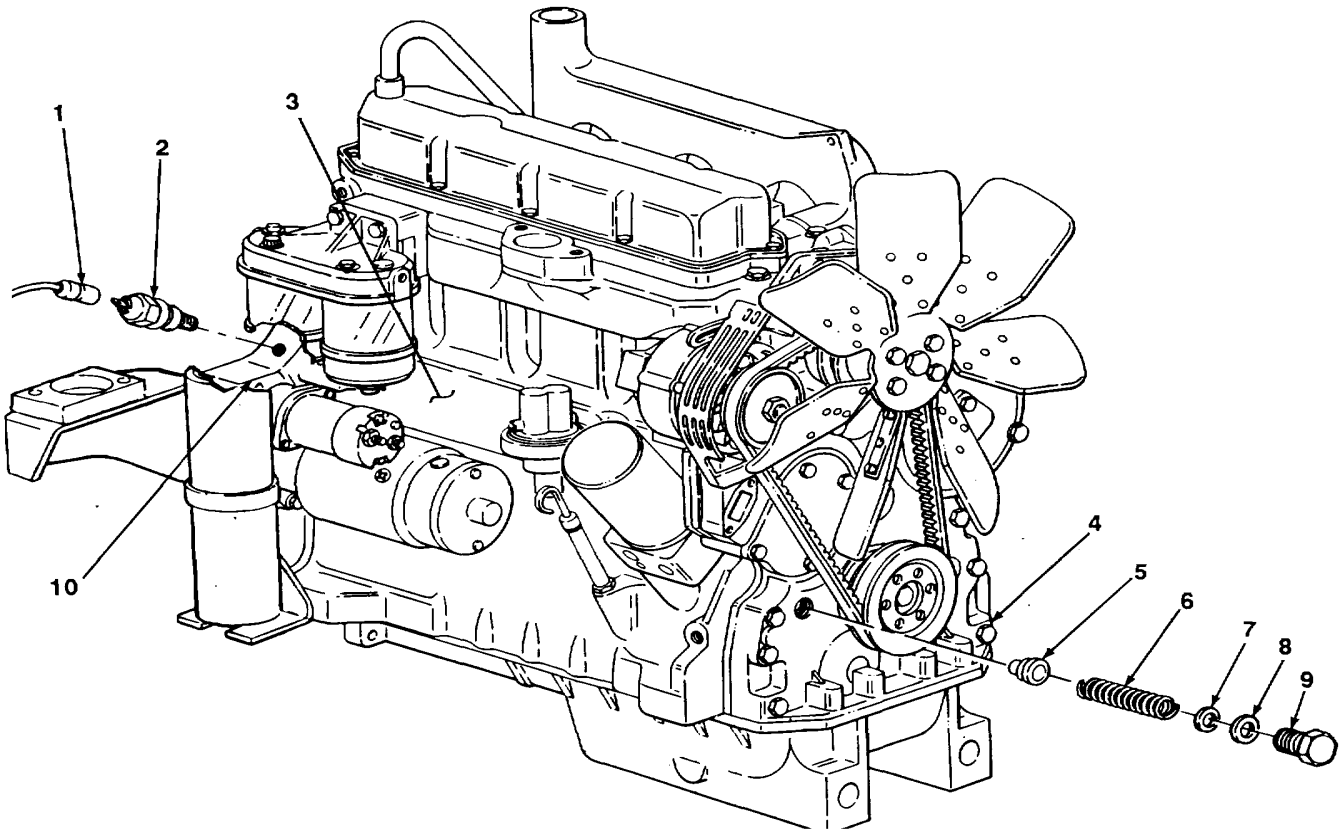
**b. CLEANING AND INSPECTION****WARNING**

Dry cleaning solvent, P-D-680, is toxic and flammable. Always wear protective goggles and gloves, and use only in a well-ventilated area. Avoid contact with skin, eyes, and clothes, and DO NOT breathe vapors. DO NOT use near open flame or excessive heat. The solvent's flash point is 100°F-138°F (38°C-59°C). If you become dizzy while using cleaning solvent, immediately get fresh air and medical help. If solvent contacts eyes, immediately wash your eyes and get medical aid.

1. Clean all metal parts in dry cleaning solvent, then dry thoroughly with clean, dry rags.

TA701303

3-22. PRESSURE REGULATING VALVE REPLACEMENT (Con't).

2. Inspect spring for cracks, breaks, and abnormal bends. Using spring tester and torque wrench, compress spring to 1.68 in. (42.67 mm) and note compression force on torque wrench. Compression force must be 14-17 lb.-ft. (19-23 N•m).
3. Inspect all other metal parts for cracks, bends, breaks, and damaged threads. Replace defective parts.

c. INSTALLATION

1. Using magnetic retrieving tool, install directional slide (5) in engine block (3).
2. Install spring (6) in timing gear cover (4) and engine block (3).
3. Install washers (7 and 8) and machine plug (9) in timing gear cover (4).

d. ADJUSTMENT

NOTE

Perform step 1 only if engine assembly is Installed.

1. Unplug and tag connector (1) from pressure switch (2).
2. Remove pressure switch (2) from flywheel housing (10).
3. Connect multirange pressure gage to flywheel housing (10).
4. Start and warm up engine assembly (see TM 5-2420-222-10). After warm-up, increase engine speed to 2500 rpm.
5. Check reading of multirange pressure gage in flywheel housing (10). Reading must be 35-65 psi (241-448 kPa) at 180°F-222°F (82°C-106°C).
6. Shut down engine assembly (see TM 5-2420-222-10).

NOTE

If pressure reading was within specification, skip steps 7 through 10.

7. Remove machine plug (9) and washers (7 and 8) from timing gear cover (4).
8. If pressure reading was too low, add another washer (7). Ensure that there are never more than four washers present.
9. If pressure reading was too high, remove one washer (7). If no washer is present, add washer.
10. Install machine plug (9) and washers (8) in timing gear cover (4). Repeat steps 4 through 6.
11. Disconnect multirange pressure gage from flywheel housing (10).
12. Install pressure switch (2) in flywheel housing (10).

NOTE

Perform step 13 only if engine assembly is Installed.

13. Plug connector (1) in pressure switch (2).

**CHAPTER 4
CLUTCH ASSEMBLY MAINTENANCE**

Paragraph Number	Paragraph Title	Page Number
4-1	Clutch Assembly Maintenance (Serial Numbers 235786-235999).....	4-1
4-2	Clutch Assembly Maintenance (Serial Numbers 319995-342573).....	4-10
4-3	Clutch Manual Control Lever Replacement.....	4-15
4-4	Clutch Disk Carrier or Clutch Support Bearing Carrier Maintenance	4-18

4-1. CLUTCH ASSEMBLY MAINTENANCE (SERIAL NUMBERS 235786-235999).

This Task Covers:

- | | | |
|--|--|--|
| <ul style="list-style-type: none"> a. Removal b. Disassembly c. Cleaning and Inspection | <ul style="list-style-type: none"> d. | <ul style="list-style-type: none"> Assembly e. Installation f. Adjustment |
|--|--|--|

Initial Setup:

Equipment Conditions:

- Engine assembly removed (see paragraph 3-3).

Tools/Test Equipment:

- General mechanic's tool kit
- Field automotive shop set
- Clutch alining tool
- Clutch finger alining tool
- Clutch rebuilder
- Vacuum cleaner

References:

- TM 9-214

Materials/Parts:

- Grease (Item 22, Appendix B)
- Rags (Item 28, Appendix B)
- Dry cleaning solvent (Item 31, Appendix B)
- Three headed straight pins
- Six lockwashers

Personnel Required: Two

General Safety Instructions:

- Dry cleaning solvent is flammable and must not be used near open flame. Use only in well-ventilated
- DO NOT use a dry brush or compressed air to clean clutch assembly or clutch components.

4-1. CLUTCH ASSEMBLY MAINTENANCE (SERIAL NUMBERS 235786-235999) (Con't).**WARNING**

Parts of clutch assembly will be coated with asbestos dust. Breathing this dust may be hazardous to your health. Use a filter mask approved for use against asbestos dust. Never use compressed air or a dry brush to clean these assemblies. Dust shall be removed using an industrial-type vacuum cleaner equipped with a high efficiency filter system.

a. REMOVAL

1. Using machinist's scribe, match-mark flywheel (1) and clutch disk assembly (4).

CAUTION

Clutch assembly is under strong spring tension. When removing clutch assembly from flywheel, release spring tension slowly and evenly to avoid damaging parts.

2. Loosen six screws (5) one turn, then repeat until all spring tension between flywheel (1) and clutch disk assembly (4) has been released.
3. Remove six screws (5) and lockwashers (6) from flywheel (1) and clutch disk assembly (4). Discard lockwashers.

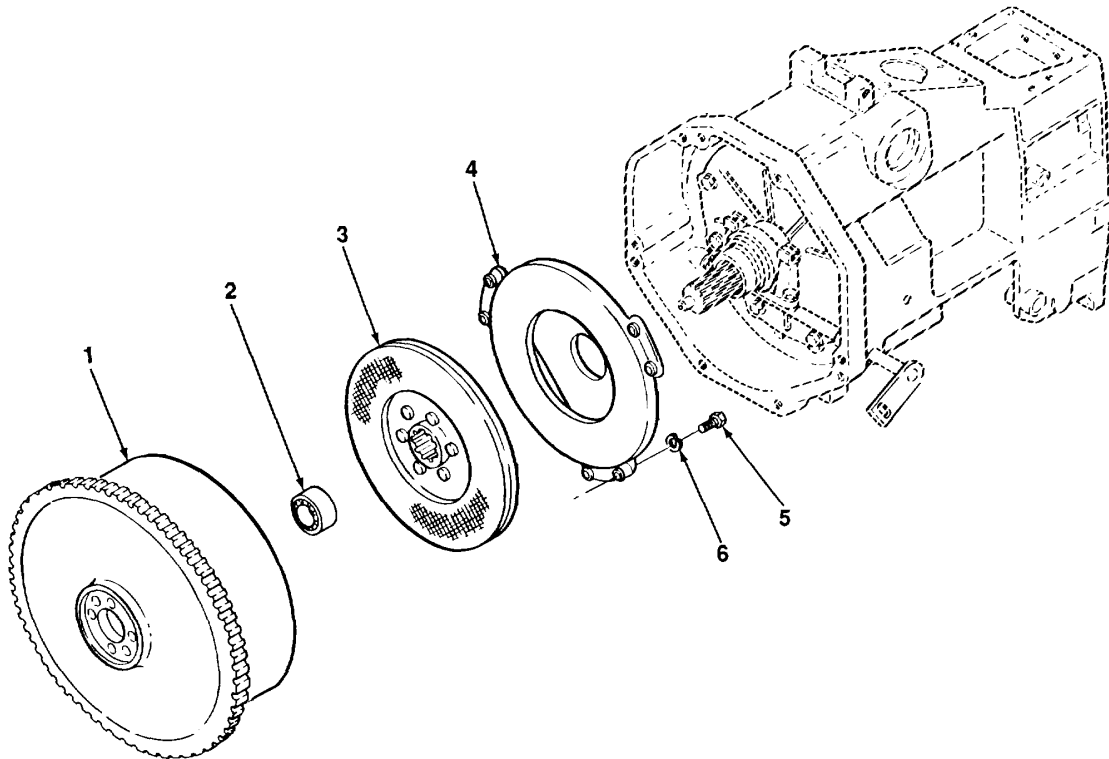

4-1. CLUTCH ASSEMBLY MAINTENANCE (SERIAL NUMBERS 235786-235999) (Con't).

4. Remove clutch disk assembly (4) and clutch disk (3) from flywheel (1).
5. Remove pilot ball bearing (2) from flywheel (1).
6. Remove two screws (10), shifter fork (13), thrust ball bearing (7), and clutch throw carrier (9) from manual control lever (12).

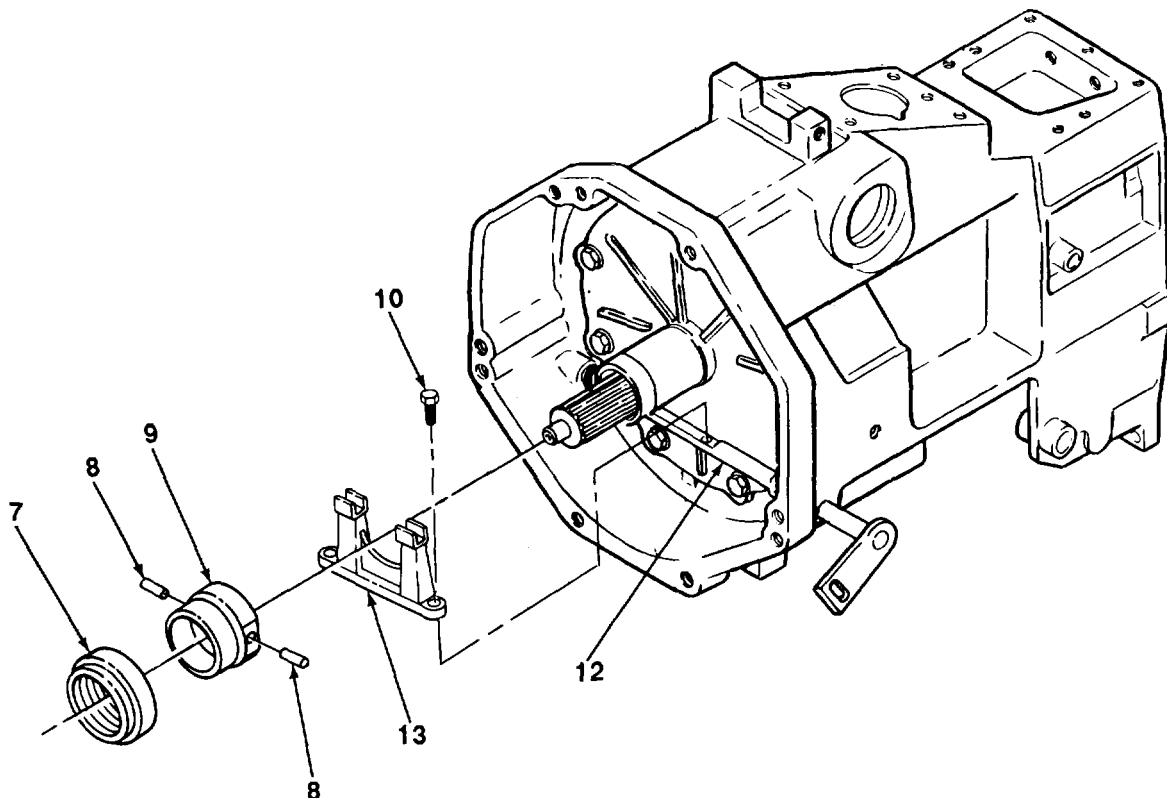
b. DISASSEMBLY
CAUTION

Use care when placing clutch throw carrier in vise. Ensure that thrust ball bearing does not become clamped in vise jaws. Damage to thrust ball bearing may result.

1. Position clutch throw carrier (9) in vise. Drive two hollow pins (8) out of clutch throw carrier. Remove clutch throw carrier from vise.

CAUTION

Do not remove thrust ball bearing from clutch throw carrier unless damaged. Removal may damage bearing.

2. Remove thrust ball bearing (7) from clutch throw carrier (9).

4-1. CLUTCH ASSEMBLY MAINTENANCE (SERIAL NUMBERS 235786-235999) (Con't).

3. Using machinist's scribe, match-mark pressure plate (14) and clutch disk assembly (4).
4. Install pressure plate (14) and clutch disk assembly (4) in clutch rebuilder. Compress pressure plate springs (15) enough to access lever screws (18).
5. Remove three jamnuts (21), lever screws (18), washers (20), and loop clamps (19) from pressure plate (14) and three remote control levers (16).
6. Remove pressure plate (14) and clutch disk assembly (4) from clutch rebuilder.
7. Using cold chisel and hammer, cut off peened ends of three headed straight pins (17). Drive pins out of clutch disk assembly (4) and three remote control levers (16). Discard pins.
8. Remove three remote control levers (16) and pressure plate springs (15) from clutch disk assembly (4).
9. Remove clutch disk assembly (4) from pressure plate (14).

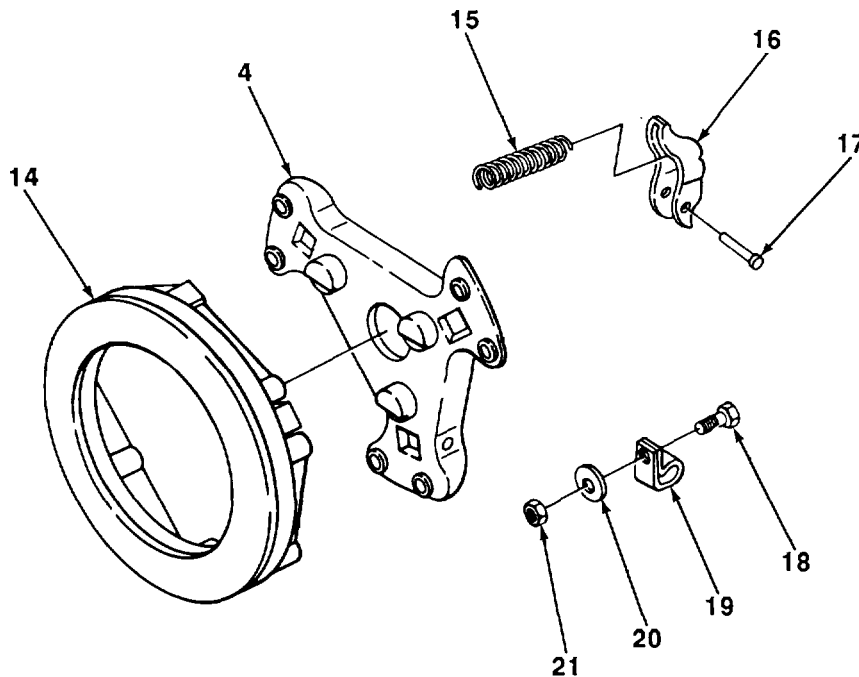
**c. CLEANING AND INSPECTION**

1. Using vacuum cleaner, clean clutch disk, pressure plate, and drive surface of flywheel. Wipe hub of clutch disk with a clean, dry rag.

TA701306

4-1. CLUTCH ASSEMBLY MAINTENANCE (SERIAL NUMBERS 235786-235999) (Con't).

WARNING

Dry cleaning solvent, P-D-680, is toxic and flammable. Always wear protective goggles and gloves, and use only in a well-ventilated area. Avoid contact with skin, eyes, and clothes, and DO NOT breathe vapors. DO NOT use near open flame or excessive heat. The solvent's flash point is 100°F-138°F (38°C-59°C). If you become dizzy while using cleaning solvent, immediately get fresh air and medical help. If solvent contacts eyes, immediately wash your eyes and get medical aid.

CAUTION

Clutch disk, clutch disk assembly, pressure plate, and thrust ball bearing must never be soaked in dry cleaning solvent. Soaking may damage parts.

2. Using rags dampened with dry cleaning solvent, wipe clutch disk, clutch disk assembly, pressure plate, and thrust ball bearing. Dry parts thoroughly with clean, dry rags.
3. Clean all other metal parts in dry cleaning solvent. Dry thoroughly with clean, dry rags.
4. Inspect engine flywheel and ring gear (see paragraph 3-9).
5. Inspect clutch disk assembly and pressure plate for cracks, breaks, and abnormal bends. Replace if defective.
6. Using combination square and thickness gage, check driving surface of pressure plate at several locations to ensure that it is flat. Flatness must be within 0.006 in. (0.152 mm).
7. Inspect pilot ball bearing and thrust ball bearing (see TM 9-214).
8. Inspect clutch disk for cracks, breaks, abnormal bends, or glazing of facing material. Using facing material above rivet heads as an indicator of wear, replace clutch disk if rivet heads are flush with or just below surface of facing material.
9. Inspect clutch disk hub spines for excessive wear. Slide clutch disk on clutch shaft. Clutch disk should slide on clutch shaft with no restrictions.
10. Ensure that clutch disk does not rock back and forth or from side to side on clutch shaft. If clutch disk rocks in either direction, use a new clutch disk and repeat steps 9 and 10 to determine if clutch disk or clutch shaft is worn.
11. If clutch shaft is worn or defective, replace clutch shaft (see paragraph 8-16).
12. Inspect three pressure plate springs for cracks, breaks, and abnormal bends. Using combination square, check pressure plate springs for tilting.
13. Using spring tester and torque wrench, compress pressure plate springs to 1.812 in. (46.025 mm). It should take 293-295 lb (1303-1312 N) of force to compress pressure plate springs. Remove spring tester.
14. Using vernier calipers, check free length of pressure plate springs. Free length should be 2.516-2.520 in. (63.906-64.008 mm).
15. Inspect all other metal parts for cracks, breaks, abnormal bends, and damaged threads. Restore damaged threads using screw threading set. Replace all defective parts.

4-1. CLUTCH ASSEMBLY MAINTENANCE (SERIAL NUMBERS 235786-235999) (Con't).

d. ASSEMBLY

1. Position clutch disk assembly (4) in place on pressure plate (14) with match-marks aligned.
2. Position three pressure plate springs (15) and remote control levers (16) in place on clutch disk assembly (4) and pressure plate (14).
3. With the aid of an assistant, compress pressure plate springs (15) by pushing down on remote control levers (16) and align pin holes in clutch disk assembly (4) and remote control levers.
4. Install three new headed straight pins (17) in clutch disk assembly (4) and remote control levers (16). Peen ends
5. Using grease and a clean rag, lightly lubricate contact points between pressure plate (14) and clutch disk assembly (4). Do not to allow grease to contact driving surface of pressure plate.
6. Position pressure plate (14) and clutch disk assembly (4) in clutch rebuilder.
7. Assemble three lever screws (18), loop clamps (19), washers (20), and jamnuts (21) partway on pressure plate (14) and clutch disk assembly (4). Ensure that loop clamps are in position on remote control levers (16) and between jamnuts and washers, then tighten lever screws and jamnuts.
8. Remove pressure plate (14) and clutch disk assembly (4) from clutch rebuilder.

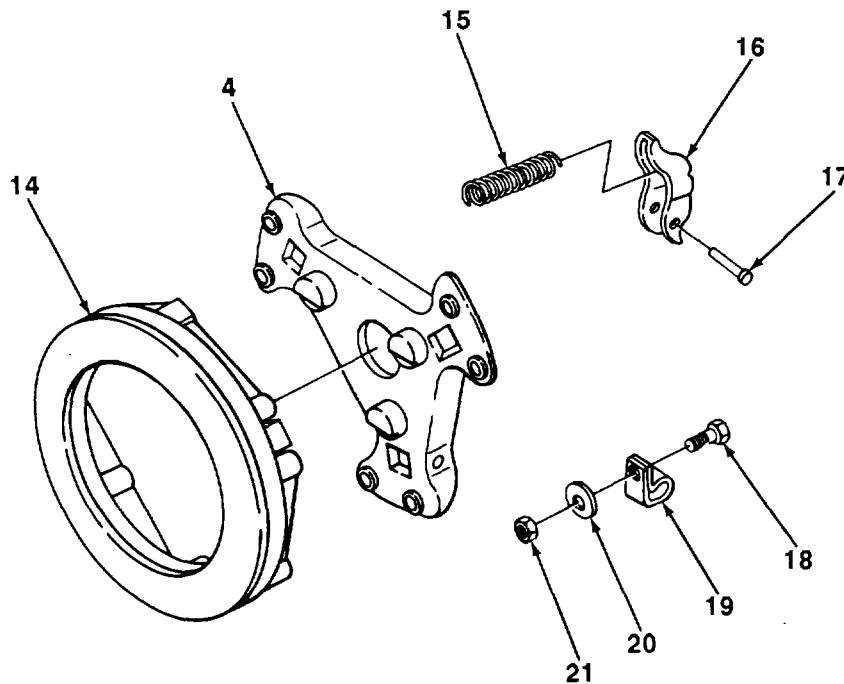

4-1. CLUTCH ASSEMBLY MAINTENANCE (SERIAL NUMBERS 235786-235999) (Con't).

9. Install thrust ball bearing (7) in clutch throw carrier (9).

CAUTION

Use care when placing clutch throw carrier in vise. Ensure that thrust ball bearing does not become clamped in vise jaws. Damage to thrust ball bearing may result.

10. Position clutch throw carrier (9) in vise with caps. Using 2 lb ball-peen hammer, tap two hollow pins (8) into clutch throw carrier, then remove from vise.

11. Position shifter fork (13) in place on clutch throw carrier (9).

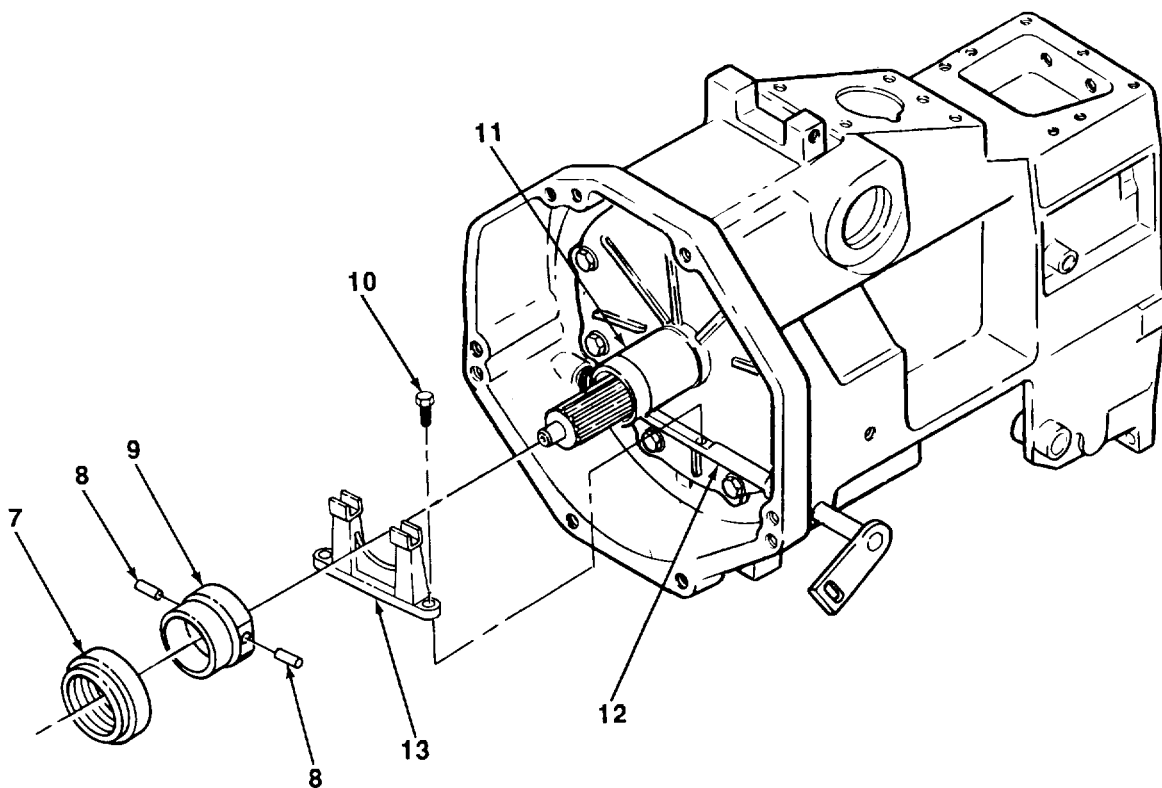
**e. INSTALLATION**

1. Position clutch throw carrier (9) with attached thrust ball bearing (7) and shifter fork (13) in place on clutch support bearing carrier (11) and manual control lever (12).
2. Install two screws (10) in shifter fork (13) and manual control lever (12). Torque screws to 35 lb.-ft. (47 N•m).

TA701308

4-1. CLUTCH ASSEMBLY MAINTENANCE (SERIAL NUMBERS 235786-235999) (Con't).

3. Install pilot ball bearing (2) in flywheel (1).
4. Position clutch alining tool in place on pilot ball bearing (2). Install clutch disk (3) on clutch alining tool and against flywheel driving surface. Ensure that long end of clutch disk faces away from flywheel (1).
5. Install clutch disk assembly (4) on clutch alining tool, clutch disk (3), and flywheel (1), then aline match-marks.
6. Install six screws (5) and new lockwashers (6) one at a time, until spring tension is felt. Tighten each screw one turn, then repeat until all six screws are tight.
7. Torque six screws (5) to 25 lb.-ft. (34 N•m). Remove clutch alining tool.

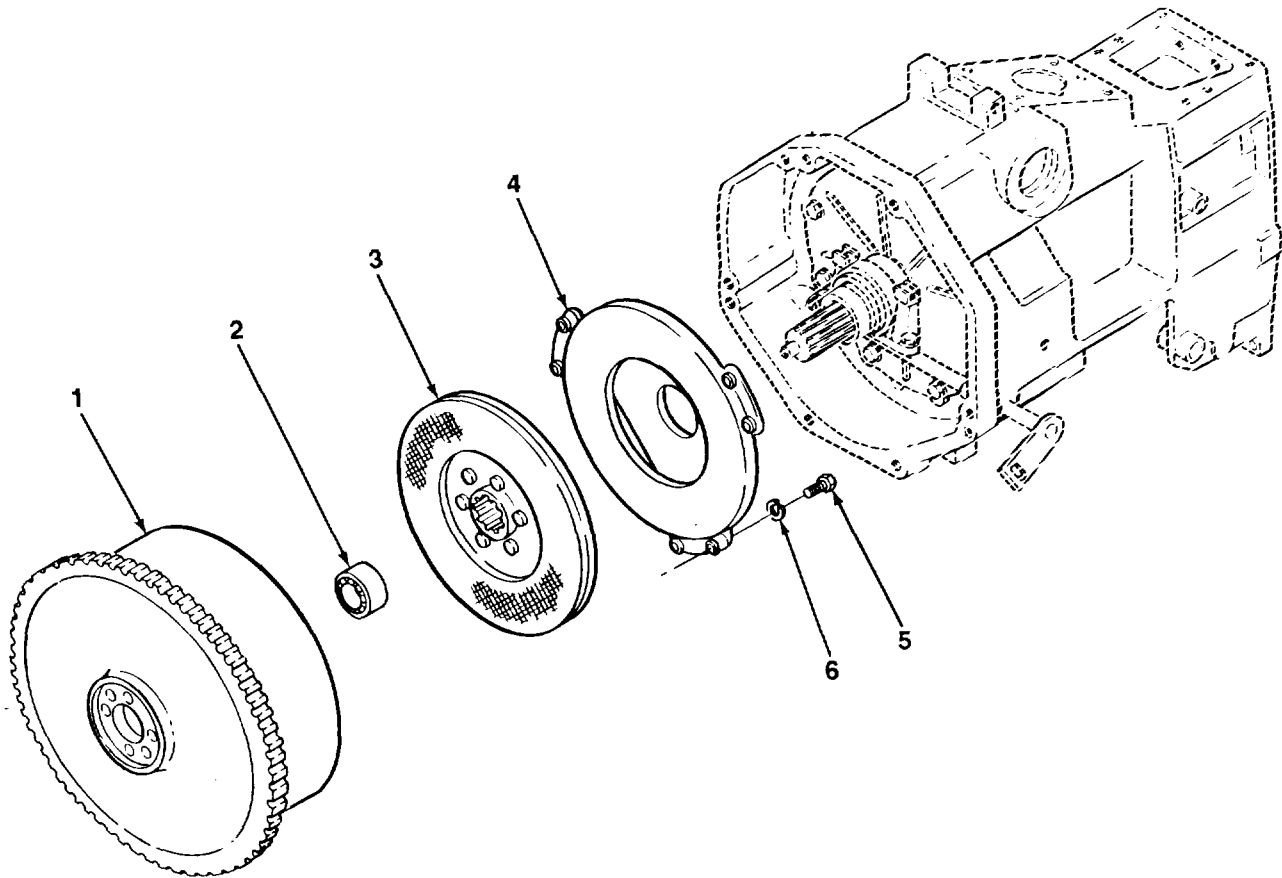

f. ADJUSTMENT

1. Working on one remote control lever (16) at a time, loosen jamnut (21) and lever screw (18) on pressure plate (14) and clutch disk assembly (4). Position step of clutch finger alining tool over remote control lever.
2. Loosen or tighten lever screw (18) until legs of clutch finger alining tool rest evenly on flywheel (1), then tighten jamnut (21).

TA701309

4-1. CLUTCH ASSEMBLY MAINTENANCE (SERIAL NUMBERS 235786-235999) (Con't).

3. Repeat steps 1 and 2 for two remaining remote control levers (16).
4. Using clutch finger alining tool and thickness gage, recheck all three remote control levers (16).
5. To ensure proper clutch functioning, variation in adjusted height of remote control levers (16) should not exceed 0.020 in. (0.508 mm). If remote control levers dropped excessively, repeat steps 1 through 4.

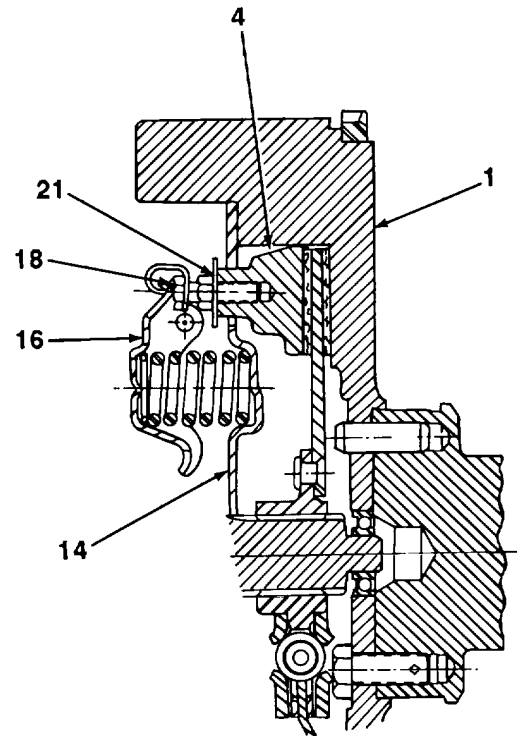
**FOLLOW-ON TASKS:**

- Install engine assembly (see paragraph 3-3).
- Adjust clutch pedal linkage (see TM 5-2420-222-20).

TA701310

4-2. CLUTCH ASSEMBLY MAINTENANCE (SERIAL NUMBERS 319995-342573).*This Task Covers:*

- | | |
|----------------------------|-----------------|
| a. Removal | d. Assembly |
| b. Disassembly | e. Installation |
| c. Cleaning and Inspection | |

*Initial Setup:***Equipment Conditions:**

- Engine assembly removed (see paragraph 3-3).

Tools/Test Equipment:

- General mechanic's tool kit
- Field automotive shop set
- Clutch alining tool
- Vacuum cleaner
- Vacuum cleaner

References:

- TM 9-214

Materials/Parts:

- Rags (Item 28, Appendix B)
- Dry cleaning solvent (Item 31, Appendix B)
- Six lockwashers

General Safety Instructions:

- Dry cleaning solvent is flammable and must not be used near open flame. Use only in a well-ventilated area.
- DO NOT use a dry brush or compressed air to clean clutch assembly or clutch components.

WARNING

Parts of clutch assembly will be coated with asbestos dust. Breathing this dust may be hazardous to your health. Use a filter mask approved for use against asbestos dust. Never use compressed air or a dry brush to clean these assemblies. Dust shall be removed using an Industrial-type vacuum cleaner equipped with a high efficiency filter system.

a. REMOVAL

1. Using machinist's scribe, match-mark flywheel (1) and clutch disk (4).

CAUTION

Clutch assembly is under strong spring tension. When removing clutch assembly from flywheel, release spring tension slowly and evenly to avoid damaging parts.

2. Loosen six screws (5) one turn, then repeat until all spring tension between flywheel (1) and clutch disk (3) has been released.
3. Remove six screws (5) and lockwashers (6) from flywheel (1) and clutch disk (4). Discard lockwashers.
4. Remove clutch disk (3) and clutch disk (4) from flywheel (1).
5. Remove pilot ball bearing (2) from flywheel (1).

4-2. CLUTCH ASSEMBLY MAINTENANCE (SERIAL NUMBERS 319995-342573). (Con't)

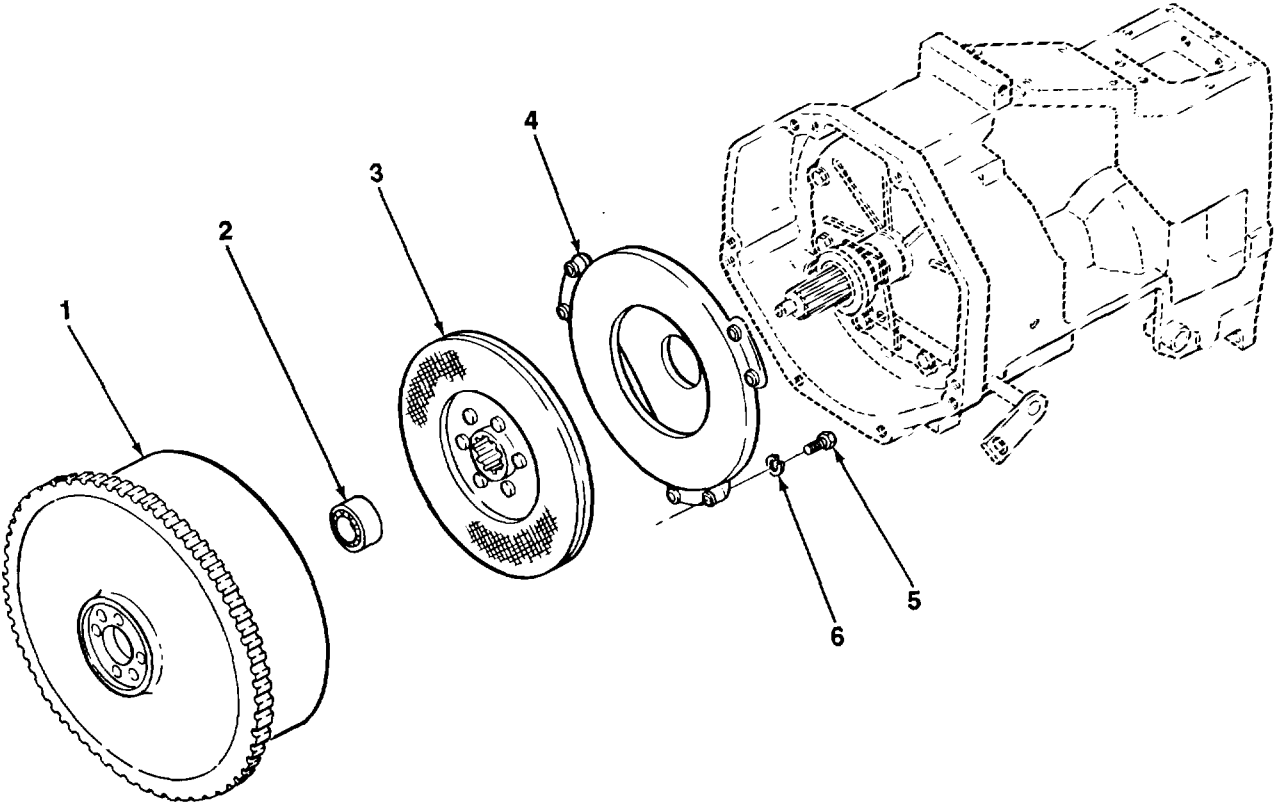

TA701311

4-2. CLUTCH ASSEMBLY MAINTENANCE (SERIAL NUMBERS 319995-342573). (Con't)

- 6. Remove four socket head screws (10), shifter fork (9), and thrust ball bearing (11) from manual control lever (8) and clutch disk carrier (7).

b. DISASSEMBLY

Remove shifter fork (9) from thrust ball bearing (11).

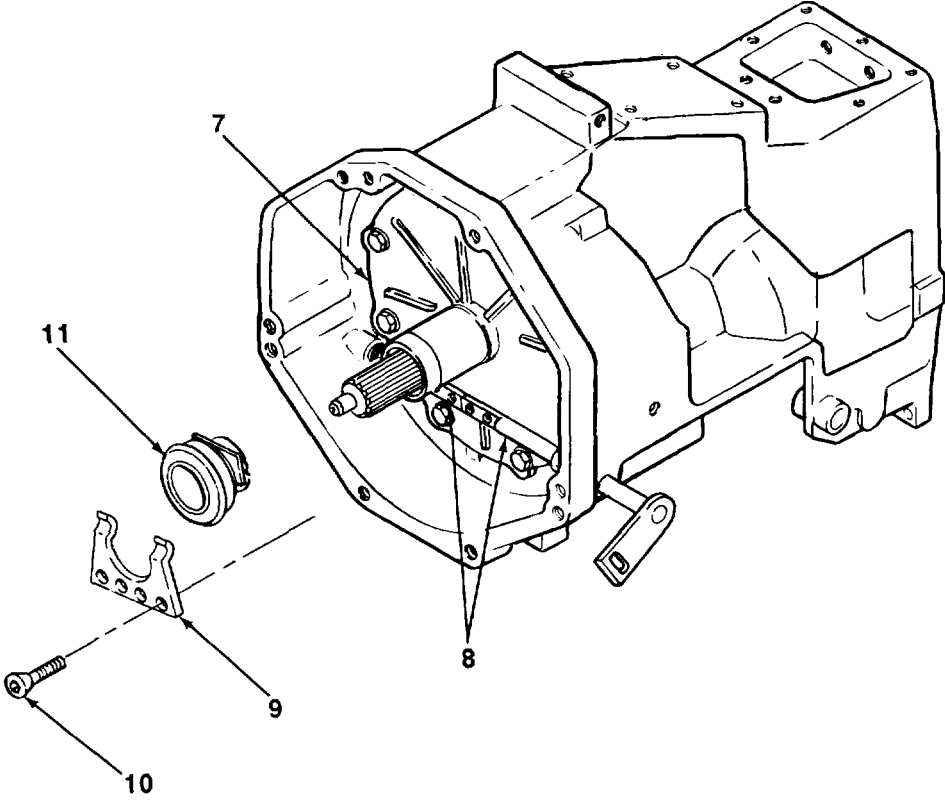

TA701312

4-2. CLUTCH ASSEMBLY MAINTENANCE (SERIAL NUMBERS 319995-342573). (Con't)

c. CLEANING AND INSPECTION

1. Using vacuum cleaner, clean clutch disks and drive surface of flywheel. Wipe hub of clutch disks with a clean, dry rag.

WARNING

Dry cleaning solvent, P-D-680, is toxic and flammable. Always wear protective goggles and gloves, and use only in a well-ventilated area. Avoid contact with skin, eyes, and clothes, and DO NOT breathe vapors. DO NOT use near open flame or excessive heat. The solvent's flash point is 100°F-138°F (38°C-59°C). If you become dizzy while using cleaning solvent, immediately get fresh air and medical help. If solvent contacts eyes, immediately wash your eyes and get medical aid.

CAUTION

Clutch disks and thrust ball bearing must never be soaked in dry cleaning solvent. Soaking may damage parts.

2. Using rags dampened with dry cleaning solvent, wipe clutch disks and thrust ball bearing. Dry parts thoroughly with clean, dry rags.
3. Clean all other metal parts in dry cleaning solvent. Dry thoroughly with clean, dry rags.
4. Inspect engine flywheel and ring gear (see paragraph 3-9).
5. Inspect clutch disks for cracks, breaks, and abnormal bends. Replace if defective.
6. Using combination square and thickness gage, check driving surface of clutch disk at several locations to ensure that it is flat. Flatness must be within 0.006 in. (0.152 mm).
7. Inspect pilot ball bearing and thrust ball bearing (see TM 9-214).
8. Inspect clutch disk for glazing of facing material. Using facing material above rivet heads as an indicator of wear, replace clutch disk if rivet heads are flush with or just below surface of facing material.
9. Inspect clutch disk hub spines for excessive wear. Slide clutch disk on clutch shaft. Clutch disk should slide on clutch shaft with no restrictions.
10. Ensure that clutch disk does not rock back and forth or from side to side on clutch shaft. If clutch disk rocks in either direction, use a new clutch disk and repeat steps 9 and 10 to determine if clutch disk or clutch shaft is worn.
11. If clutch shaft is worn or defective, replace clutch shaft (see paragraph 8-16).
12. Inspect all other metal parts for cracks, breaks, abnormal bends, and damaged threads. Restore damaged threads using screw threading set. Replace all defective parts.

d. ASSEMBLY

Position shifter fork (9) in place on thrust ball bearing (11).

e. INSTALLATION

1. Position thrust ball bearing (11) and shifter fork (9) in place on clutch disk carrier (7) and manual control lever (8).
2. Install four socket head screws (10) in shifter fork (9) and manual control lever (8). Torque screws to 35 lb.-ft. (47 N•m).

4-2. CLUTCH ASSEMBLY MAINTENANCE (SERIAL NUMBERS 319995-342573). (Con't)

3. Install pilot ball bearing (2) in flywheel (1).
4. Position clutch alining tool in place on pilot ball bearing (2). Install clutch disk (3) on clutch alining tool and against flywheel driving surface. Ensure that long end of clutch disk faces away from flywheel (1).
5. Install clutch disk (4) on clutch alining tool, clutch disk (3), and flywheel (1). Install six screws (5) and new lockwashers (6), one at a time, until spring tension is felt. Tighten each screw one turn, then repeat until all six screws are tight.
6. Torque six screws (5) to 25 lb.-ft. (34 N•m). Remove clutch alining tool.

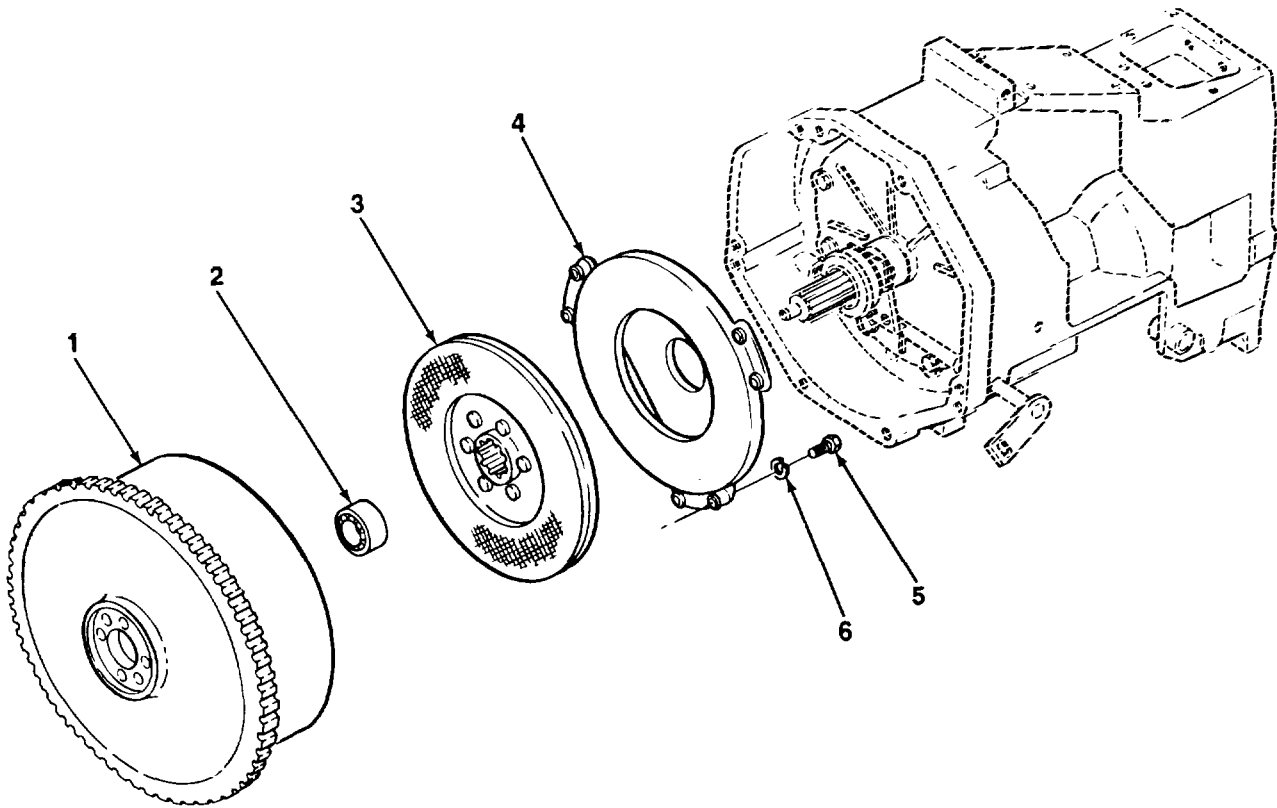
**FOLLOW-ON TASKS:**

- Install engine assembly (see paragraph 3-3).
- Adjust clutch pedal linkage (see TM 5-2420-222-20).

4-3. CLUTCH MANUAL CONTROL LEVER REPLACEMENT.

This Task Covers:

- | | | |
|----------------------------|----|--------------|
| a. Removal | c. | Installation |
| b. Cleaning and Inspection | | |
-

*Initial Setup:***Equipment Conditions:**

- Clutch assembly removed (see paragraph 4-1 or 4-2).

Tools/Test Equipment:

- General mechanic's tool kit
- Field automotive shop set
- Clutch alining tool
- Vacuum cleaner

Materials/Parts:

- Rags (Item 28, Appendix B)
- Dry cleaning solvent (Item 31, Appendix B)
- One spring pin

General Safety Instructions:

- Dry cleaning solvent is flammable and must not be used near open flame. Use only in a well-ventilated area.
 - DO NOT use a dry brush or compressed air to clean clutch assembly or clutch components.
-

4-3. CLUTCH MANUAL CONTROL LEVER REPLACEMENT. (Con't)

WARNING

Parts of clutch assembly will be coated with asbestos dust. Breathing this dust may be hazardous to your health. Use a filter mask approved for use against asbestos dust. Never use compressed air or a dry brush to clean these assemblies. Dust shall be removed using an Industrial-type vacuum cleaner equipped with a high efficiency filter system.

a. REMOVAL

1. Note position of spring (4) on spring pin (3) and reverser housing (1) to ensure proper installation. Drive spring pin out of manual control lever. Discard spring pin.
2. Hold spring (4) and remove manual control lever (2) from reverser housing (1) and clutch bushing (5).

CAUTION

Do not remove clutch bushing unless damaged. Removal may damage parts.

3. Using brass drift and hammer, drive clutch bushing (5) out of reverser housing (1).

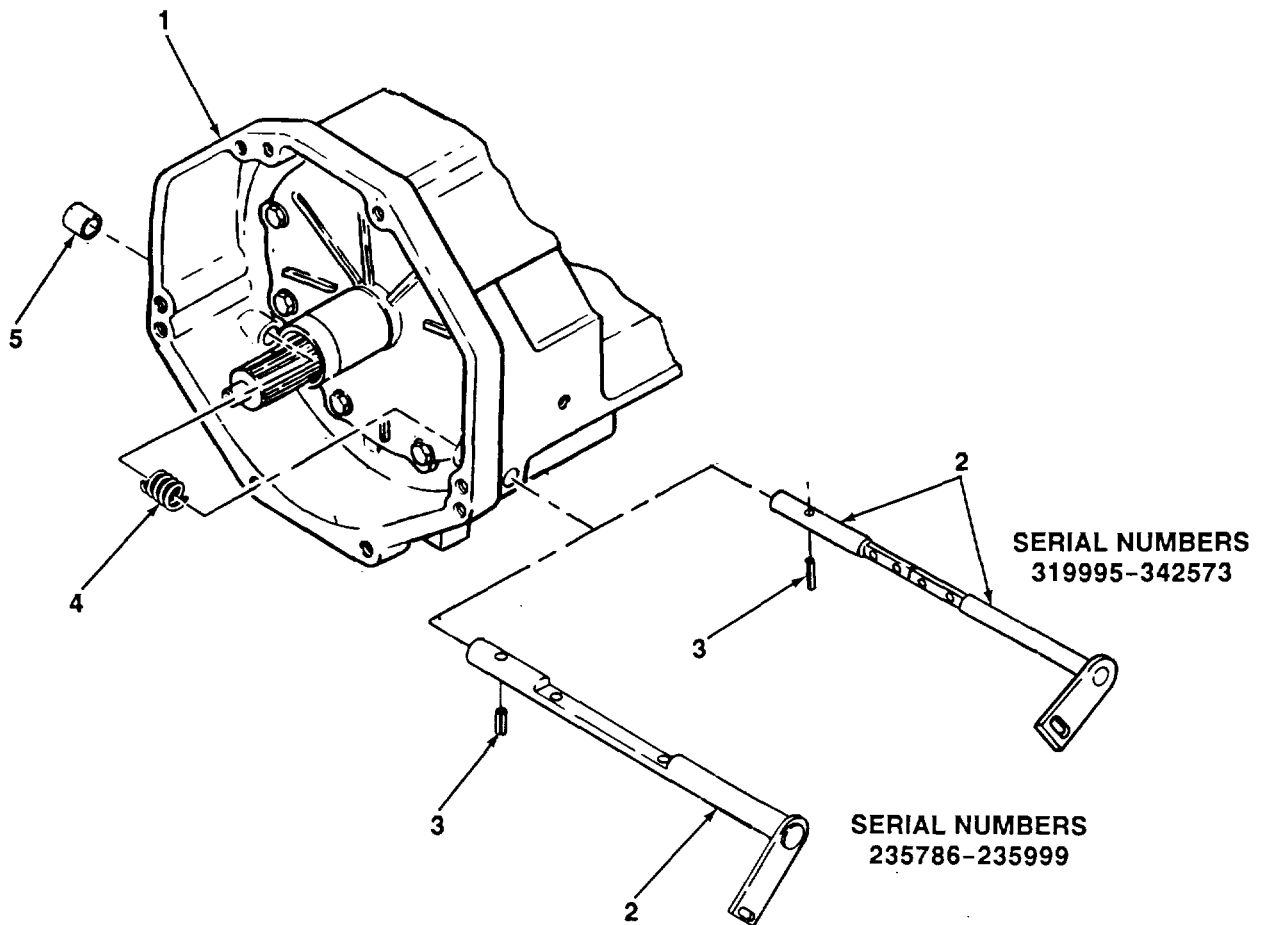

4-3. CLUTCH MANUAL CONTROL LEVER REPLACEMENT. (Con't)

b. CLEANING AND INSPECTION

1. Use a vacuum cleaner to remove dust particles from parts.

WARNING

Dry cleaning solvent, P-D-680, is toxic and flammable. Always wear protective goggles and gloves, and use only in a well-ventilated area. Avoid contact with skin, eyes, and clothes, and DO NOT breathe vapors. DO NOT use near open flame or excessive heat. The solvent's flash point is 100°F-138°F (38°C-59°C). If you become dizzy while using cleaning solvent, immediately get fresh air and medical help. If solvent contacts eyes, immediately wash your eyes and get medical aid.

2. Using rags and dry cleaning solvent, clean manual control lever. Dry thoroughly with clean, dry rags.
3. Clean all other metal parts with dry cleaning solvent. Dry thoroughly with clean, dry rags.
4. Inspect manual control lever for cracks, breaks, abnormal bends, and damaged threads. Restore damaged threads using screw threading set. Replace manual control lever if defective.
5. Inspect all other metal parts for cracks, breaks, and abnormal bends. Replace defective parts.

c. INSTALLATION**NOTE**

Perform step 1 only if clutch bushing was removed.

1. Using brass drift and hammer, install clutch bushing (5) in reverser housing (1).
2. Slide manual control lever (2) halfway through reverser housing (1). Install spring (4) in place on manual control
3. Slide manual control lever (2) through reverser housing (1) and into clutch bushing (5). Ensure that manual control lever only slides into clutch bushing partway.
4. Slide spring (4) against clutch bushing (5) and install new spring pin (3) in manual control lever (2) until 0.31 in. (7.87 mm) remains sticking out. Using vernier calipers, check measurement of spring pin often.
5. If spring pin (3) is driven in too far, drive spring pin out partway and repeat step 4.
6. Place ends of spring (4) in place on spring pin (3) and reverser housing (1) as noted during removal.

FOLLOW-ON TASKS:

- Install clutch assembly (see paragraph 4-1 or 4-2).
- Adjust clutch pedal linkage (see TM 5-2420-222-20).

4-4. CLUTCH DISK CARRIER OR CLUTCH SUPPORT BEARING CARRIER MAINTENANCE.

This Task Covers:

- | | | |
|----------------------------|----|-----------------|
| a. Removal | d. | Assembly |
| b. Disassembly | | e. Installation |
| c. Cleaning and Inspection | | |
-

*Initial Setup.***Equipment Conditions:**

- Clutch manual control lever removed (see paragraph 4-3).

Tools/Test Equipment:

- General mechanic's tool kit
- Field automotive shop set
- Clutch alining tool
- Vacuum cleaner

Materials/Parts:

- Rags (Item 28, Appendix B)
- * Dry cleaning solvent (item 31, Appendix B)
- One preformed packing
- One seal
- One preformed packing
- Eight lockwashers

General Safety Instructions:

- Dry cleaning solvent is flammable and must not be used near open flame. Use only in a well-ventilated
 - DO NOT use a dry brush or compressed air to clean clutch assembly or clutch components.
-

WARNING

Parts of clutch assembly will be coated with asbestos dust. Breathing this dust may be hazardous to your health. Use a filter mask approved for use against asbestos dust. Never use compressed air or a dry brush to clean these assemblies. Dust shall be removed using an industrial-type vacuum cleaner equipped with a high efficiency filter system.

a. REMOVAL

1. Remove eight screws (1) and lockwashers (2) from carrier (3) and reverser housing (4). Discard lockwashers.
2. Remove carrier (3) with attached parts from reverser housing (4).

b. DISASSEMBLY

1. Remove preformed packing (5) from carrier (3). Discard preformed packing.
2. Using gear and bearing mechanical puller, remove seal (6) from carrier (3). Discard seal.

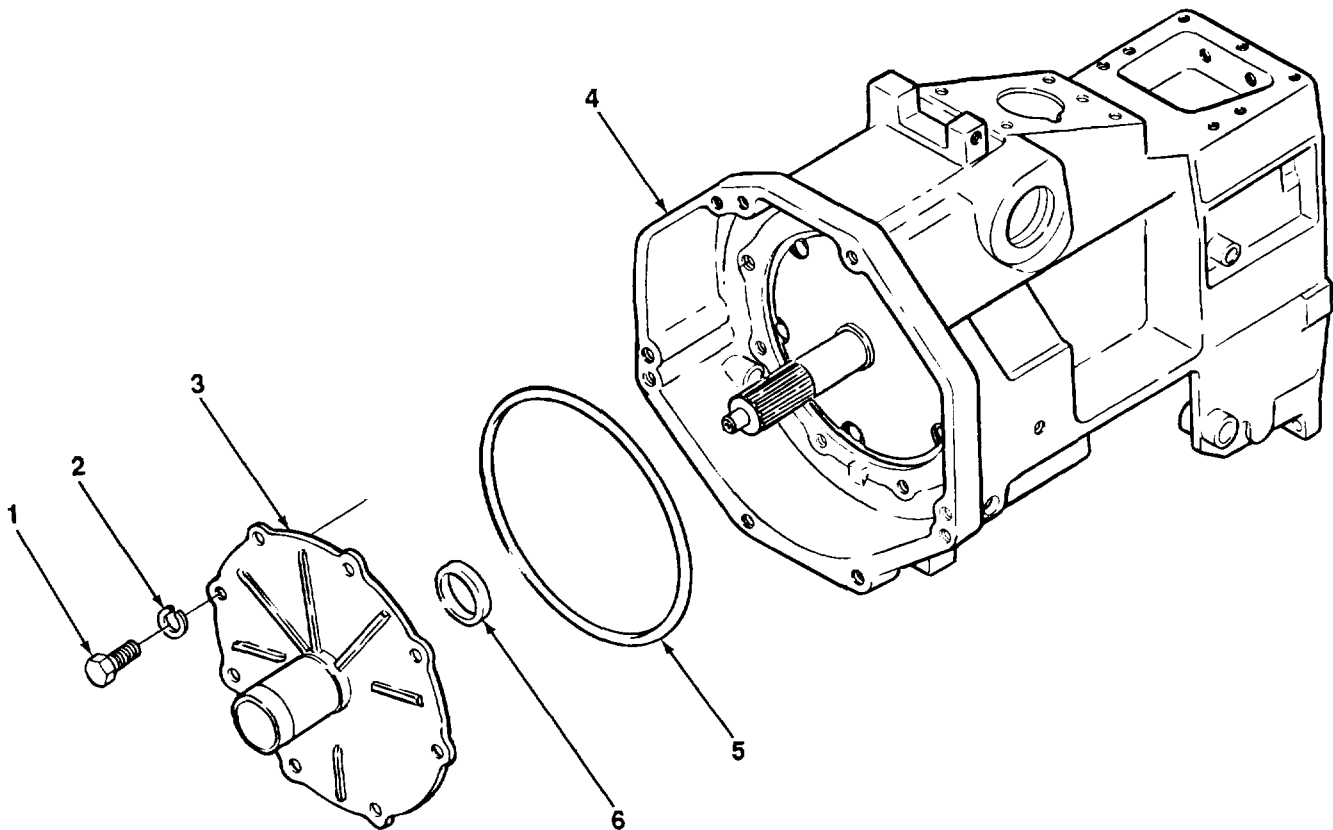
4-4. CLUTCH DISK CARRIER OR CLUTCH SUPPORT BEARING CARRIER MAINTENANCE (Con't).**c. CLEANING AND INSPECTION**

1. Use a vacuum cleaner to remove dust particles from parts.

WARNING

Dry cleaning solvent, P-D-680, is toxic and flammable. Always wear protective goggles and gloves, and use only in a well-ventilated area. Avoid contact with skin, eyes, and clothes, and DO NOT breathe vapors. DO NOT use near open flame or excessive heat. The solvent's flash point is 100°F-138°F (38°C-59°C). If you become dizzy while using cleaning solvent, immediately get fresh air and medical help. If solvent contacts eyes, immediately wash your eyes and get medical aid.

2. Using rags and dry cleaning solvent, wipe carrier clean, then dry thoroughly with clean rags.
3. Inspect carrier for cracks, breaks, and abnormal bends. Replace if defective.

TA701315

4-4. CLUTCH DISK CARRIER OR CLUTCH SUPPORT BEARING CARRIER MAINTENANCE (Con't).**d. ASSEMBLY**

1. Using brass drift and hammer, tap new seal (6) until evenly seated in carrier (3).
2. Position new preformed packing (5) in place on carrier (3).

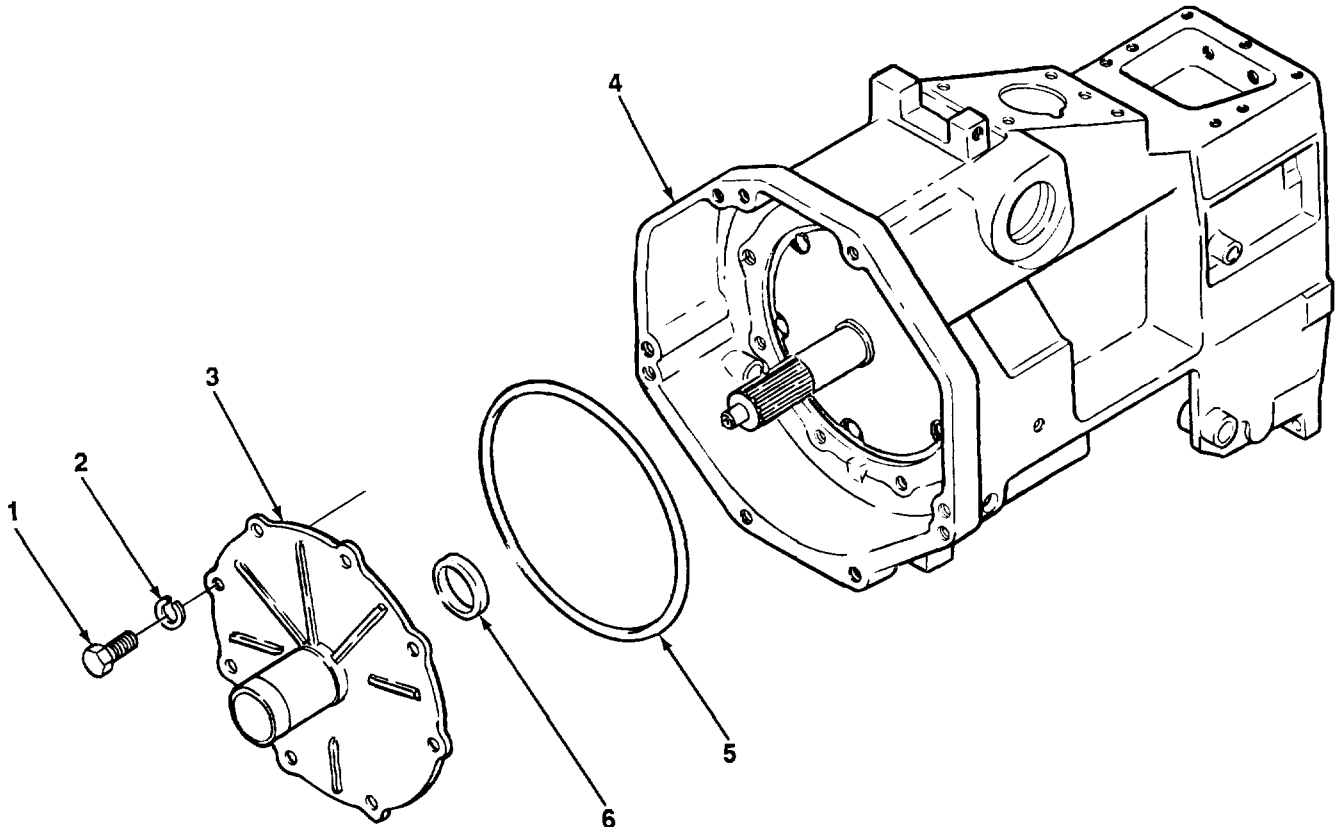
**e. INSTALLATION**

1. Position carrier (3) with assembled parts in place in reverser housing (4).
2. Install eight screws (1) and new lockwashers (2) in carrier (3) and reverser housing (4).

FOLLOW-ON TASKS:

- Install clutch manual control lever (see paragraph 4-3).

TA701316

CHAPTER 5
FUEL SYSTEM MAINTENANCE

Paragraph Number	Paragraph Title	Page Number
5-1	Fuel Injection Nozzles Test and Repair.....	5-1
5-2	Fuel Metering Pump Replacement.....	5-9
5-3	Fuel Metering Pump Helical Gear Replacement.....	5-15
5-4	Fuel Tank Repair	5-18
5-5	Speed Control Shaft Replacement.....	5-18

5-1. FUEL INJECTION NOZZLES TEST AND REPAIR.

This Task Covers:

- a. Test and Adjustment
- b. Disassembly
- c. Cleaning and Inspection
- d. Repair
- e. Assembly

Initial Setup:

Equipment Conditions:

- Fuel injection nozzle removed (see TM 5-2420-222-20).

Tools/Test Equipment:

- General mechanic's tool kit
- Field automotive shop set
- Brass wire brush
- Cleaning wire, 0.008 in.
- Cleaning wire, 0.01 in.
- Inspection magnifier
- Nozzle holding fixture
- Sac hole drill
- Tip seat scraper
- Valve retractor

Materials/Parts:

- Carbon removing compound (Item 8, Appendix B)
- Lapping compound (Item 10, Appendix B)
- Diesel fuel (Item 17, Appendix B)
- Plastic gloves (Item 21, Appendix B)
- Lint-free wipes (Item 43, Appendix B)

References:

- TM 9-4910-409-12

General Safety Instructions:

- DO NOT perform this procedure near fire, flames, or sparks.

5-1. FUEL INJECTION NOZZLES TEST AND REPAIR (Con't).

NOTE

There are four fuel injection nozzles. One is shown. Repeat procedure for remaining fuel injection nozzles as required.

a. TEST AND ADJUSTMENT

WARNING

- Carbon removing compound is a corrosive liquid. If splashed in eyes, it can cause blindness. If splashed on skin, it can cause serious burns. Be sure to wear safety goggles or lenses, rubber apron, and rubber gloves. If accidentally splashed in eyes or on skin, flush with clean, cool water, refer to FM 21 -1 1 for first aid information, and get medical attention immediately.
- No open flames, welding, grinding, smoking, or use of heat producing devices permitted nearby when using fuel. Fuel burns easily and fumes are explosive. Keep battery disconnected. Failure to observe these precautions may cause serious injury or death to personnel.

CAUTION

Do not scrape or otherwise damage protective coating on nozzle body above carbon washer groove. Do not let carbon removing compound contact nozzle body above carbon washer groove. Do not clean nozzle body with motor driven brush. Any of these actions will damage fuel injection nozzle.

NOTE

- Fuel injection nozzles should be tested and adjusted before disassembly to determine if disassembly is needed, and after assembly to ensure proper operation of new or reconditioned parts.
 - If fuel injection nozzle has just been reconditioned, skip step 1.
1. Soak nozzle tip (6) overnight in carbon removing compound, then rinse with clean diesel fuel.
 2. Using brass wire brush and clean diesel fuel, clean nozzle tip (6).
 3. Test fuel injection nozzle opening pressure (see TM 9-4910-409-12). New fuel injection nozzle or fuel injection nozzle with new spring should have opening pressure of 3150-3250 psi (21,719- 22,409 kPa). Fuel injection nozzle in service should have opening pressure of 2950-3050 psi (20,340-21,030 kPa).

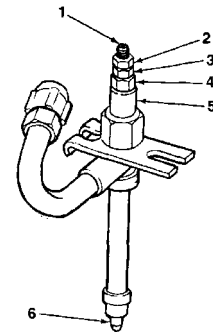

TA701317

5-1. FUEL INJECTION NOZZLES TEST AND REPAIR (Con't).

NOTE

If opening pressure is correct, skip steps 4 through 8. If making second or later adjustment, skip steps 3 and 4. If correct opening pressure cannot be obtained after several tries, fuel injection nozzle must be disassembled, cleaned, inspected, and repaired.

4. Loosen adjusting nut (4) from fuel injection nozzle (5) and pressure adjusting screw (3).
5. Hold pressure adjusting screw (3) and loosen locknut (2) from pressure adjusting screw and lift adjusting screw (1).
6. Tighten lift adjusting screw (1) as far as it will go into pressure adjusting screw (3).
7. If making first adjustment, back lift adjusting screw (1) out of pressure adjusting screw (3) one full turn. If making second or later adjustment, back lift adjusting screw out of pressure adjusting screw 12 turns.
8. If opening pressure measured in step 3 was too low, turn pressure adjusting screw (3) clockwise to increase opening pressure. If opening pressure was too high, turn pressure adjusting screw counterclockwise to decrease opening pressure. Repeat steps 3 through 8.
9. Hold pressure adjusting screw (3) to keep it from turning and torque locknut (2) to 35-45 lb.-in. (4.0-5.1 N•m). Ensure that lift adjusting screw (1) does not turn.
10. Hold pressure adjusting screw (3) to keep it from turning and torque adjusting nut (4) to 70-80 lb.-in. (7.9-9.0 N•m). Repeat steps 3 through 10.

NOTE

If spray pattern is incorrect, or fuel injection nozzle leaks or chatters, fuel injection nozzle must be disassembled, cleaned, inspected, and repaired.

11. Test spray pattern of fuel injection nozzle (5) with assembled parts (see TM 9-4910-409-12). Spray pattern should be finely atomized, even, and cone-shaped, without gaps or irregularities.
12. Test leakage of fuel injection nozzle (5) with assembled parts (see TM 9-4910-409-12). Leakage from return end of nozzle should be 3-10 drops in 30 seconds at 1500 psi (10,343 kPa).
13. Test chatter of fuel injection nozzle (5) with assembled parts (see TM 9-4910-409-12). Fuel injection nozzle should chatter softly and consistently. An occasional miss is acceptable.

5-1. FUEL INJECTION NOZZLES TEST AND REPAIR (Con't).

b. DISASSEMBLY

WARNING

• No open flames, welding, grinding, smoking, or use of heat producing devices permitted nearby when using fuel. Fuel burns easily and fumes are explosive. Keep battery disconnected. Failure to observe these precautions may cause serious Injury or death to personnel.

• Plastic gloves must be worn and kept clean and lubricated with clean diesel fuel while working on Internal parts of fuel Injection nozzle. Ensure that work area is exceptionally clean. Dirt and lint will cause damage, excessive wear, leakage, or clogs to fuel Injection nozzles.

CAUTION

Disassemble, clean, inspect, and assemble fuel Injection nozzles one at a time to avoid mixing parts. Fuel Injection nozzle parts are machined to very close tolerances. Mixing parts may cause leakage, poor performance, or damage to parts.

1. Position fuel Injection nozzle (5) with assembled parts in nozzle holding fixture and vise.
2. Loosen adjusting nut (4) partway. Remove locknut (2) from pressure adjusting screw (3) and lift adjusting screw (1).
3. Remove pressure adjusting screw (3), lift adjusting screw (1), and adjusting nut (4) from fuel injection nozzle (5).
4. Remove fuel injection nozzle (5) with assembled parts from nozzle holding fixture and vise. Do not tip fuel injection nozzle and spill internal parts.

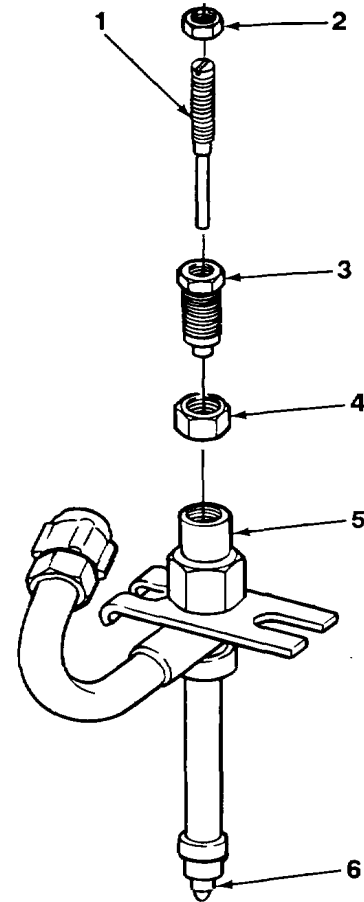
**CAUTION**

Do not bend valve when removing it from fuel injection nozzle. Bending may damage parts.

5. Tilt fuel injection nozzle (5) and allow spring (7), spring seat (8), and valve (9) to slide into hand. If valve does not slide freely from nozzle, use valve retractor to remove valve.
6. Remove lift adjusting screw (1) and adjusting nut (4) from pressure adjusting screw (3).
7. Remove dust cap (13) from fuel injection nozzle (5).

TA701318

5-1. FUEL INJECTION NOZZLES TEST AND REPAIR (Con't).

c. CLEANING AND INSPECTION

WARNING

- **No open flames, welding, grinding, smoking, or use of heat producing devices permitted nearby when using fuel. Fuel burns easily and fumes are explosive. Keep battery disconnected. Failure to observe these precautions may cause serious injury or death to personnel.**
- **Plastic gloves must be worn and kept clean and lubricated with clean diesel fuel while working on internal parts of fuel injection nozzle. Ensure that work area is exceptionally clean. Dirt and lint will cause damage, excessive wear, leakage, or clogs to fuel injection nozzles.**

1. Using brass wire brush, clean carbon washer groove (10) in fuel injection nozzle (5).
2. Using machinist's rule, clamp 0.008 in. cleaning wire in pin vise, so that cleaning wire extends no more than 1/3 in. (0.79 mm) out of pin vise.
3. Using sharpening stone, flatten one side of cleaning wire to aid in removing carbon deposits from fuel injection nozzle(s).
4. Insert 0.008 in. cleaning wire in fuel injection nozzle holes and rotate from side to side to remove carbon deposits from fuel injection nozzle(s).
5. Remove 0.008 in. cleaning wire from vise and repeat steps 2 through 4 using 0.01 in. cleaning wire.
6. Using tip seat scraper, remove any carbon deposits from valve seating area (12) of fuel injection nozzle (5).
7. Using sac hole drill and valve retractor, remove any carbon deposits from sac hole (11).
8. Using brass wire brush, remove any carbon deposits from seating area on tip of valve (9). If varnish is present, remove with a lint-free wipe.
9. Clean all other metal parts with clean diesel fuel.
10. Inspect fuel injection nozzle for cracks, breaks, and abnormal bends.
11. Using inspection magnifier, inspect nozzle tip (6) for cracks, breaks, abnormal bends, chipping, and erosion.
12. Inspect valve (9) for cracks, breaks, and abnormal bends. Using inspection magnifier, look for scratches which could cause sticking.

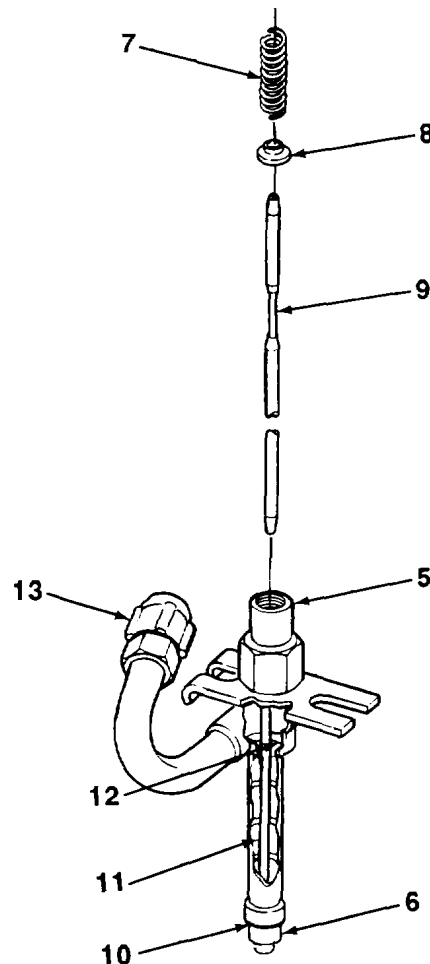

5-1. FUEL INJECTION NOZZLES TEST AND REPAIR (Con't).

13. Inspect adjusting nut, lift adjusting screw, pressure adjusting screw, locknut, spring, and spring seat for cracks, bends, breaks, or stripped threads. If damaged, replace fuel injection nozzle.
14. Inspect all other metal parts for cracks, breaks, abnormal bends, and damaged threads. Replace defective parts.

d. REPAIR

WARNING

- **No open flames, welding, grinding, smoking, or use of heat producing devices permitted nearby when using fuel. Fuel burns easily and fumes are explosive. Keep battery disconnected. Failure to observe these precautions may cause serious injury or death to personnel.**
 - **Plastic gloves must be worn and kept clean and lubricated with clean diesel fuel while working on internal parts of fuel injection nozzle. Ensure that work are is exceptionally clean. Dirt and lint will cause damage, excessive wear leakage, or clogs to fuel injection nozzles.**
1. If fuel injection nozzle (5) has shown spotty chatter or signs of sticking and low return leakage during test, place a small amount of lapping compound on guide area of valve (9).
 2. Slide valve (9) into fuel injection nozzle (5). Using valve retractor, grip top of valve and turn in fuel injection nozzle 10-20 times. Raise and lower valve every three turns.
 3. Remove valve (9) from fuel injection nozzle (5) and rinse thoroughly with clean diesel fuel.
 4. If excess leakage was detected at nozzle tip (6) during test, place a small amount of lapping compound on tip of valve (9) only.
 5. Slide valve (9) into fuel injection nozzle (5). Using valve retractor, grip top of valve and turn in fuel injection nozzle three to five times.
 6. Remove valve (9) from fuel injection nozzle (5) and rinse thoroughly with clean diesel fuel.

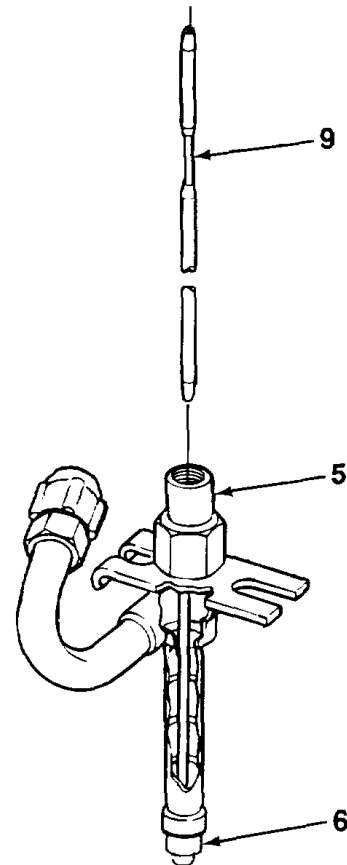

5-1. FUEL INJECTION NOZZLES TEST AND REPAIR (Con't).

e. ASSEMBLY

WARNING

- No open flames, welding, grinding, smoking, or use of heat producing devices permitted nearby when using fuel. Fuel burns easily and fumes are explosive. Keep battery disconnected. Failure to observe these precautions may cause serious Injury or death to personnel.
- Plastic gloves must be worn and kept clean and lubricated with clean diesel fuel while working on Internal parts of fuel Injection nozzle. Ensure that work area is exceptionally clean. Dirt and lint will cause damage, excessive wear, leakage, or clogs to fuel injection nozzles.

CAUTION

Soak all fuel Injection nozzle internal parts in clean diesel fuel before assembly. Fuel injection nozzle internal parts which have not been thoroughly soaked in diesel fuel before assembly will be damaged during test or operation.

1. Soak valve (9), pressure adjusting screw (3), lift adjusting screw (1), spring (7), and spring seat (8) in clean diesel fuel.
2. Install dust cap (13) on fuel injection nozzle (5).
3. Slide valve (9) into fuel injection nozzle (5).
4. Install lift adjusting screw (1) partway on pressure adjusting screw (3).
5. Install adjusting nut (4) on pressure adjusting screw (3) as far as it will go.
6. Install spring (7) and spring seat (8) on pressure adjusting screw (3). Ensure that parts do not fall off.
7. Install pressure adjusting screw (3) with assembled parts in fuel injection nozzle (5) and valve (9). Tighten adjusting nut (4) until snug, then loosen one full turn.

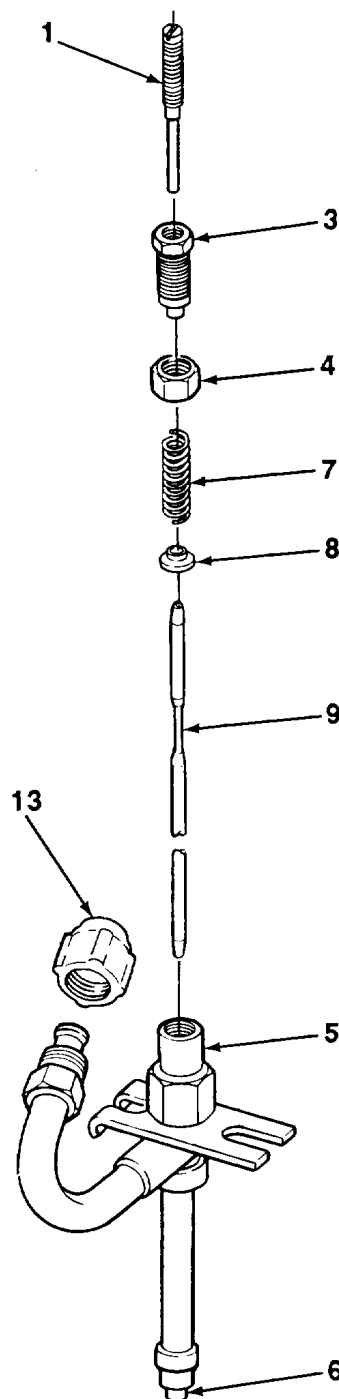

TA701321

5-1. FUEL INJECTION NOZZLES TEST AND REPAIR (Con't).

8. Tighten lift adjusting screw (1) on pressure adjusting screw (3) until snug, then loosen two full turns.
9. Install fuel injection nozzle (5) with assembled parts in nozzle holding fixture and vise.
10. Tighten adjusting nut (4) on fuel injection nozzle (5) and pressure adjusting screw (3) until snug. Ensure that pressure adjusting screw does not turn.
11. Install locknut (2) partway on pressure adjusting screw (3) and lift adjusting screw (1), then remove fuel injection nozzle (5) with assembled parts from nozzle holding fixture and vise.

NOTE

The following check must be performed during assembly to ensure proper operation.

12. Install fuel injection nozzle (5) with assembled parts in diesel fuel injection nozzle tester (see TM 9-4910-409-12).
13. Hold lift adjusting screw (1) with wrench to prevent turning. While pumping fuel through fuel injection nozzle (5), tighten lift adjusting screw until valve (9) no longer opens.
14. Check for valve bottoming by increasing pressure to 200-500 psi (1379-3448 kPa) above fuel injection nozzle opening pressure. Some diesel fuel may collect at nozzle tip (6), but a rapid dribble should not be present. If excess leakage is present, replace fuel injection nozzle (5).
15. Hold pressure adjusting screw (3) with wrench to prevent turning. Torque locknut (2) to 35-45 lb.-in. (4.0-5.1 N•m).
16. Hold pressure adjusting screw (3) with wrench to prevent turning. Torque adjusting nut (4) to 70-80 lb.-in. (7.9-9.0 Nm).
17. Repeat test and adjustment (see subparagraph a).

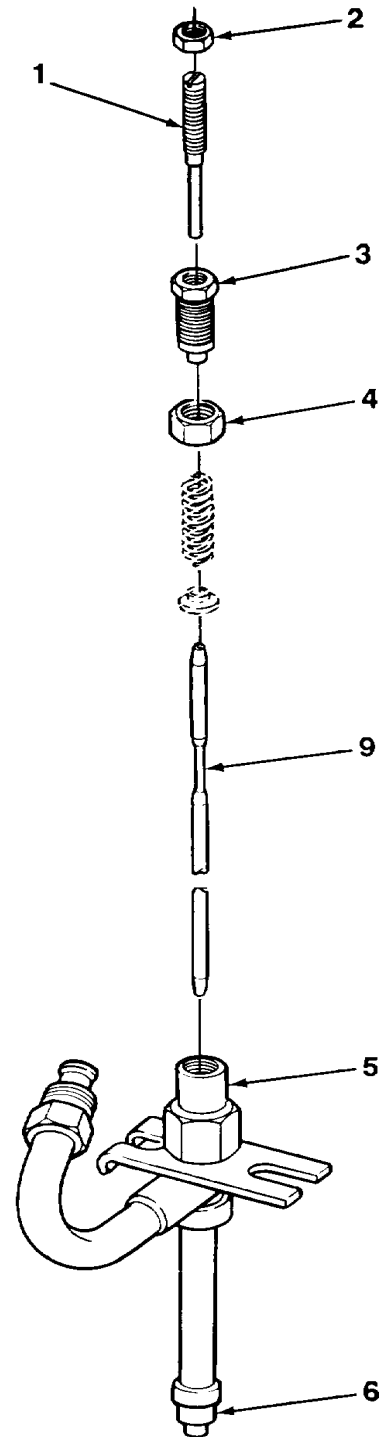
**FOLLOW-ON TASKS:**

- Install fuel injection nozzle (see TM 5-2420-222-20).

5-2. FUEL METERING PUMP REPLACEMENT.*This Task Covers:*

- a. Removal
- b. Installation

*Initial Setup:***Equipment Conditions:**

- Hood removed (see TM 5-2420-222-20).
- Battery ground cable disconnected (see TM 5-2420-222-20).

Tools/Test Equipment:

- General mechanic's tool kit
- Automotive fuel and electrical tool kit
- Electrical repair shop set

References:

- TM 5-2420-222-10

Materials/Parts:

- Grease (Item 22, Appendix B)
- Rags (Item 28, Appendix B)
- Marker tags (Item 32, Appendix B)
- One cotter pin
- One cotter pin
- Two lockwashers
- Eight washers

General Safety Instructions:

- DO NOT perform this procedure near fire, flames, or sparks.

a. REMOVAL

1. Remove pin (1) and cover (2) from flywheel housing (3).

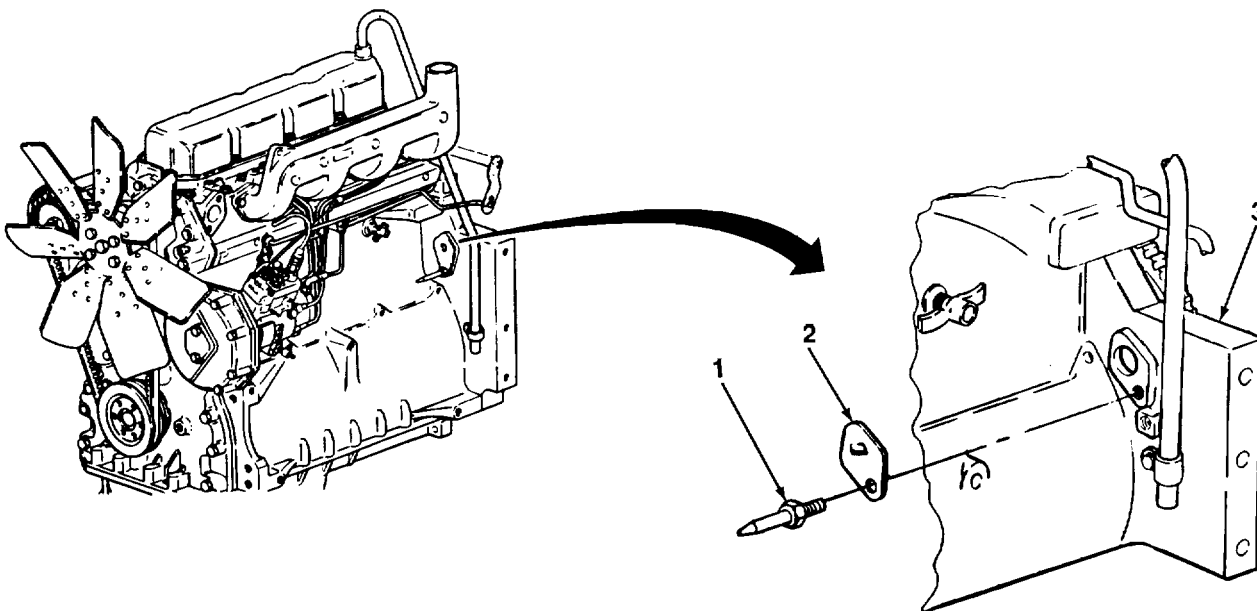

TA701323

5-2. FUEL METERING PUMP REPLACEMENT (Con't).

NOTE

- Cylinders are numbered from one to four starting at front of engine.
- No. 1 cylinder is at top dead center (TDC) when both of its valves are fully closed and hole in flywheel is aligned with timing hole in flywheel housing.

2. Manually crank engine assembly until no 1 cylinder is at TDC (see TM 5-2420-222-10).

NOTE

If pin cannot be installed all the way into flywheel, repeat step 2.

3. Install pin (1) through timing hole in flywheel housing (3) until fully seated in hole of flywheel (4).

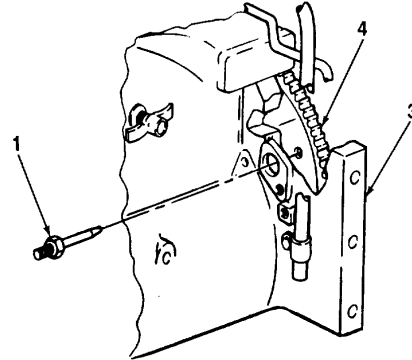
**WARNING**

No open flame, welding, grinding, smoking, or use of heat producing devices, permitted nearby when using fuel. Fuel burns easily and fumes are explosive. Keep battery disconnected. Failure to observe these precautions may cause serious injury or death to personnel.

CAUTION

- Do not steam clean or spray cold water on a warm fuel metering pump. Water may damage warm metal parts of pump.
- Ensure that all fuel connections and surrounding areas on fuel metering pump are free of dirt, dust, and grease. Fuel system components may be damaged by contaminants entering fuel system.

TA701324

5-2. FUEL METERING PUMP REPLACEMENT (Con't).**NOTE**

- Use a drain pan to catch fluid when disconnecting lines and tubes. Clean up all spills.
- Tag lines and tubes to ensure proper installation

4. Disconnect line (15) from elbow (14).
5. Disconnect line (13) from connector (12).

NOTE

Four tubes are disconnected the same way. One is shown. Repeat step 6 for remaining tubes.

6. Remove screw (19), two washers (18), and tube (17) from hydraulic head (16). Discard washers.
7. Remove cotter pin (9), rod (11), and washer (10) from throttle lever assembly (8). Discard cotter pin.
8. Remove locknut (6) and terminal (5) from shutoff solenoid terminal (7). Discard locknut.

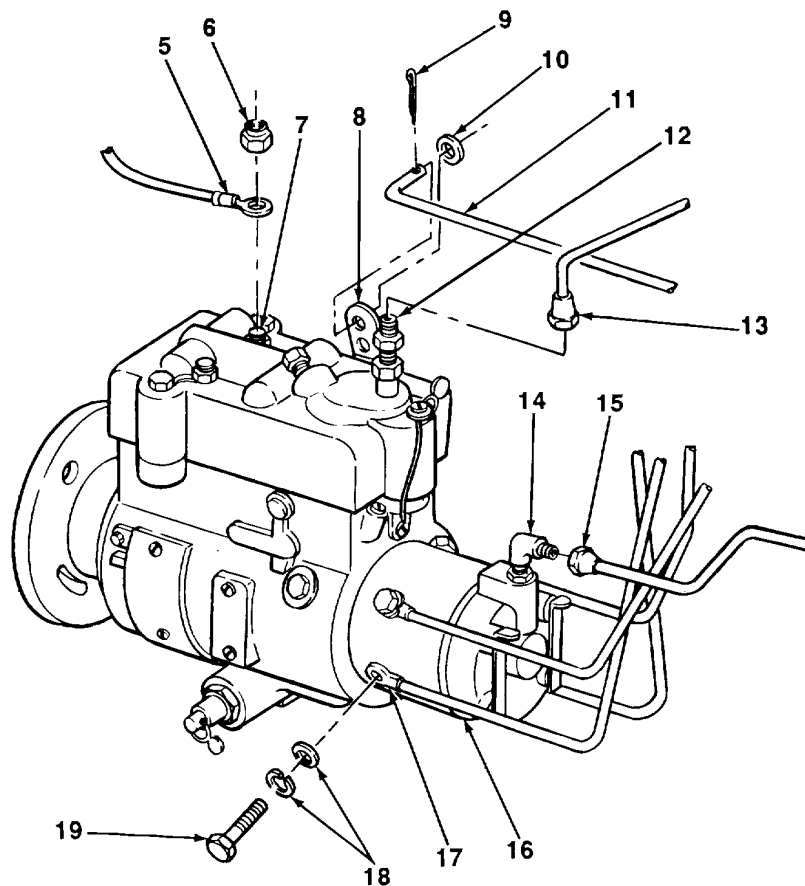

5-2. FUEL METERING PUMP REPLACEMENT (Con't).

9. Remove two nuts (22), lockwashers (23), and washers (24) from fuel metering pump (21) and two studs (20). Discard lockwashers.
10. Remove fuel metering pump helical gear (see paragraph 5-3).

CAUTION

Do not tip fuel metering pump over or internal parts may fall out and become damaged.

11. Remove fuel metering pump (21).

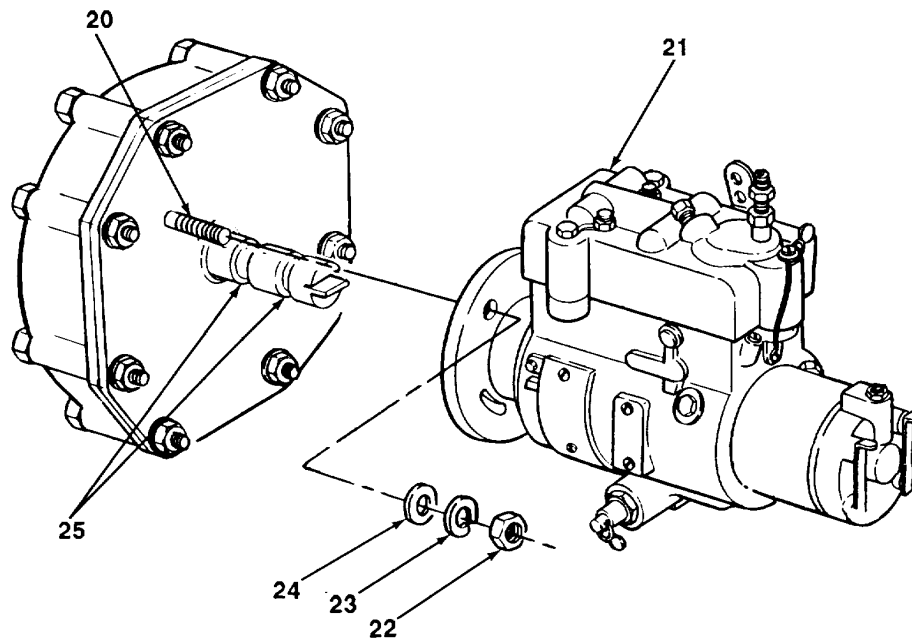
**b. INSTALLATION**

1. Position fuel metering pump (21) on engine front plate.
2. Install fuel metering pump helical gear (see paragraph 5-3).
3. Coat drive shaft seals (25) with grease.
4. Move fuel metering pump (21) in and out to ensure that drive shaft seals (25) are not turned over. Slide fuel metering pump until fully seated on two studs (20).
5. Install two washers (24), new lockwashers (23), and nuts (22) on studs (20).
6. Install terminal (5) and new locknut (6) on shutoff solenoid terminal (7).
7. Install rod (11), washer (10), and new cotter pin (9) on throttle lever assembly (8).

5-2. FUEL METERING PUMP REPLACEMENT (Con't).

NOTE

Four tubes are connected the same way. One is shown. Repeat step 8 for remaining tubes.

- 8. Install screw (19), two new washers (18), and tube (17) on hydraulic head (16).
- 9. Connect line (13) to connector (12).
- 10. Connect line (15) to elbow (14).

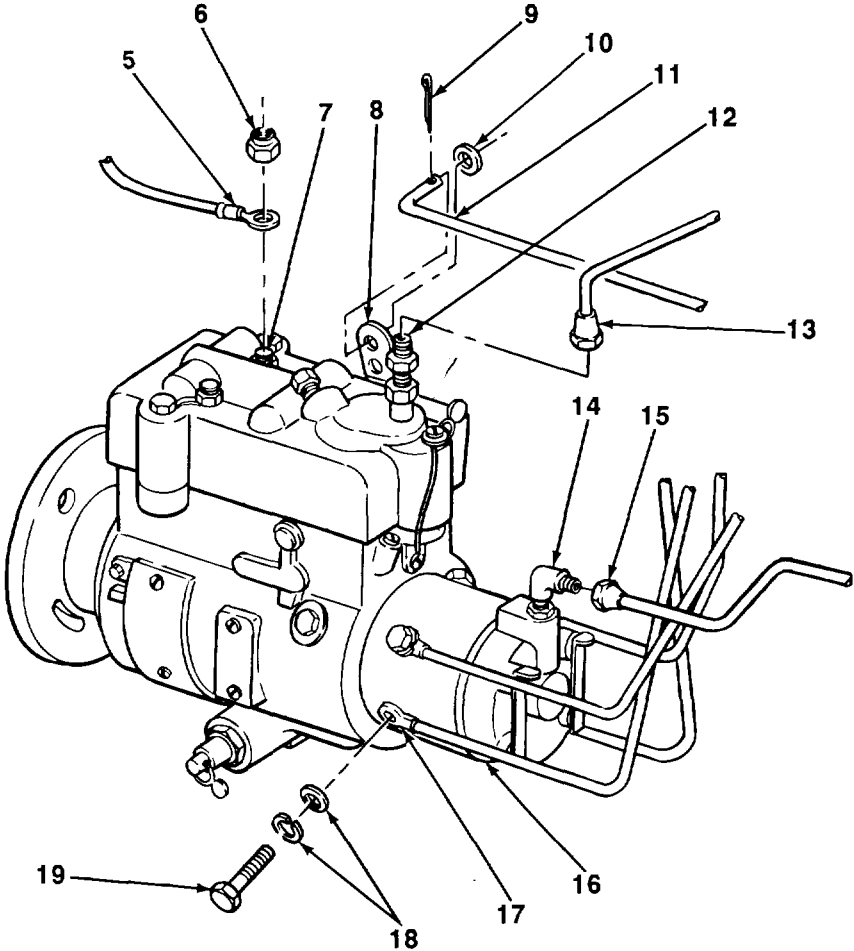

5-2. FUEL METERING PUMP REPLACEMENT (Con't).

11. Remove pin (1) from flywheel (4) and flywheel housing (3).
12. Install pin (1) and cover (2) on flywheel housing (3).

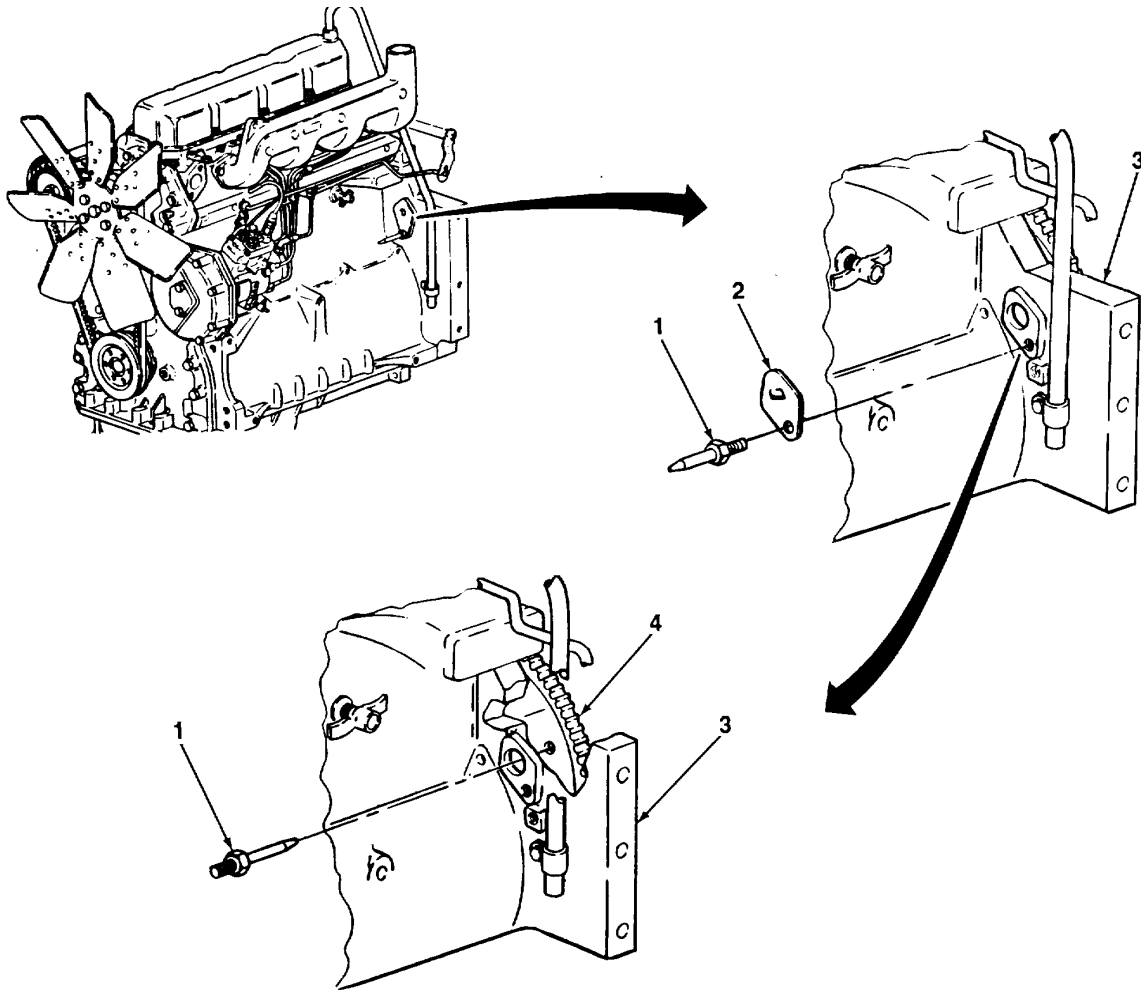
**FOLLOW-ON TASKS:**

- Connect battery ground cable (see TM 5-2420-222-20).
- Start engine assembly and check for leaks (see TM 5-2420-222-10).
- Install hood (see TM 5-2420-222-20).

TA701328

5-3. FUEL METERING PUMP HELICAL GEAR REPLACEMENT.*This Task Covers:*

- | | |
|----------------------------|-----------------|
| a. Removal | c. Installation |
| b. Cleaning and Inspection | |

*Initial Setup:***Equipment Conditions:**

- Valve cover removed (see TM 5-2420-222-20).

Materials/Parts:

- Rags (Item 28, Appendix B)
- Dry cleaning solvent (Item 31, Appendix B)
- One lockwasher

Tools/Test Equipment:

- General mechanic's tool kit
- Field automotive shop set
- Timing alinement tool

General Safety Instructions:

- Dry cleaning solvent is flammable and must not be used near open flame. Use only in a well-ventilated area.

References:

- TM 5-2420-222-10

a. REMOVAL**NOTE**

- Cylinders are numbered from one to four starting at fan end of engine assembly.
- No. 1 cylinder is at top dead center (TDC) when both of its valves are fully closed and hole in flywheel is alined with timing hole in flywheel housing.

- Remove pin (1) and cover (2) from flywheel housing (4).
- Manually crank engine assembly until no.1 cylinder is at TDC (see TM 5-2420-222-10).
- Insert pin (1) through timing hole in flywheel housing (4) until it seats in hole of flywheel (3).

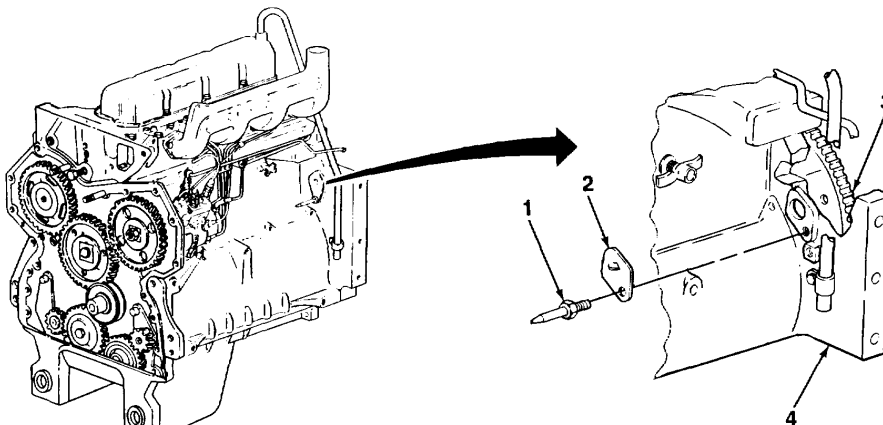

5-3. FUEL METERING PUMP HELICAL GEAR REPLACEMENT (Con't).

4. Remove timing gear cover (see paragraph 3-18).
5. Remove nut (9) and lockwasher (10). Use mechanical gear puller to remove fuel metering pump helical gear (8) from fuel metering pump drive shaft (5) and upper idler gear (7). Discard lockwasher.

b. CLEANING AND INSPECTION**WARNING**

Dry cleaning solvent, P-D-680, is toxic and flammable. Always wear protective goggles and gloves, and use only in a well-ventilated area. Avoid contact with skin, eyes, and clothes, and DO NOT breathe vapors. DO NOT use near open flame or excessive heat. The solvent's flash point is 100°F-138°F (38°C-59°C). If you become dizzy while using cleaning solvent, immediately get fresh air and medical help. If solvent contacts eyes, immediately wash your eyes and get medical aid.

1. Clean fuel metering pump helical gear with dry cleaning solvent and rags. Dry thoroughly with clean, dry rags.
2. Inspect fuel metering pump helical gear and nut for cracks, breaks, bends, burrs, and damaged threads. Replace if defective.

c. INSTALLATION

1. Install fuel metering pump helical gear (8) on end of fuel metering pump drive shaft (5).
2. Install nut (9) and new lockwasher (10) on fuel metering pump drive shaft (5) and fuel metering pump helical gear (8). Torque nut to 45 lb.-ft. (61 N•m).
3. Using timing alignment tool, align timing slash-mark on fuel metering pump helical gear (8) with center of crankshaft (6). Push fuel metering pump helical gear and fuel metering pump drive shaft (5) in until gears are meshed.
4. Install timing gear cover (see paragraph 3-18).
5. Remove pin (1) from flywheel (3) and flywheel housing (4).
6. Install pin (1) and cover (2) on flywheel housing (4).

5-3. FUEL METERING PUMP HELICAL GEAR REPLACEMENT (Con't).

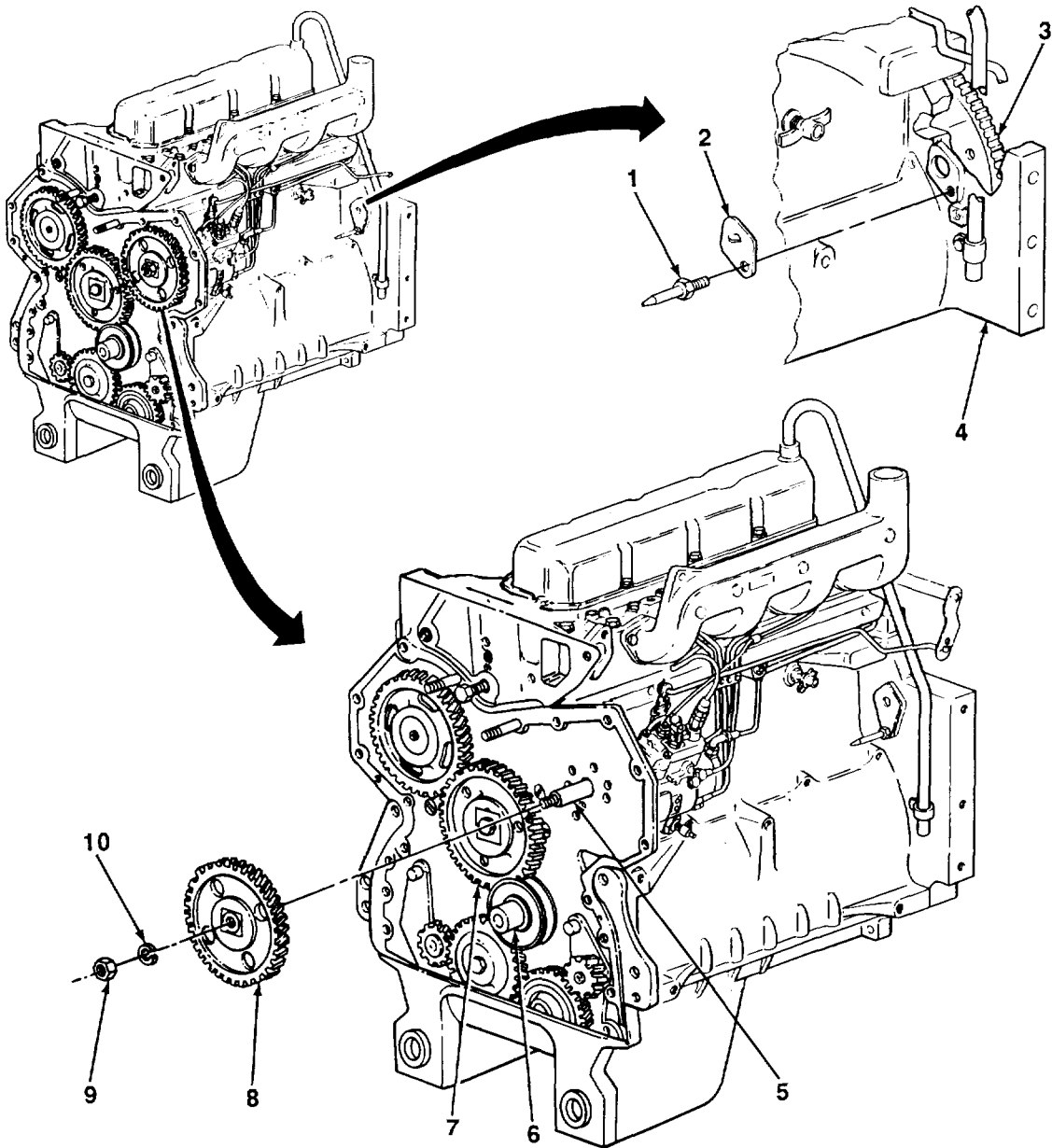

FOLLOW-ON TASKS:

- Install valve cover (see TM 5-2420-222-20).

TA701330

5-4. FUEL TANK REPAIR.

For information on fuel tank repair, refer to TB 43-0212.

5-5. SPEED CONTROL SHAFT REPLACEMENT.

This Task Covers:

- | | |
|----------------------------|-----------------|
| a. Removal | c. Installation |
| b. Cleaning and Inspection | |

Initial Setup:

Equipment Conditions:

- Speed control arms removed (see TM 5-2420-222-20).
- Cowl support removed (see paragraph 13-5).

Tools/Test Equipment:

- General mechanic's tool kit

Materials/Parts:

- Grease (Item 22, Appendix B)
- Rags (Item 28, Appendix B)
- Dry cleaning solvent (Item 31, Appendix B)
- One cotter pin

General Safety Instructions

- Dry cleaning solvent is flammable and must not be used near open flame. Use only in a well-ventilated area.

a. REMOVAL

1. Remove cotter pin (4), washer (5), and speed control rod (1) from speed control shaft (2). Discard cotter pin.
2. remove speed control shaft (2) from cowl support (3).

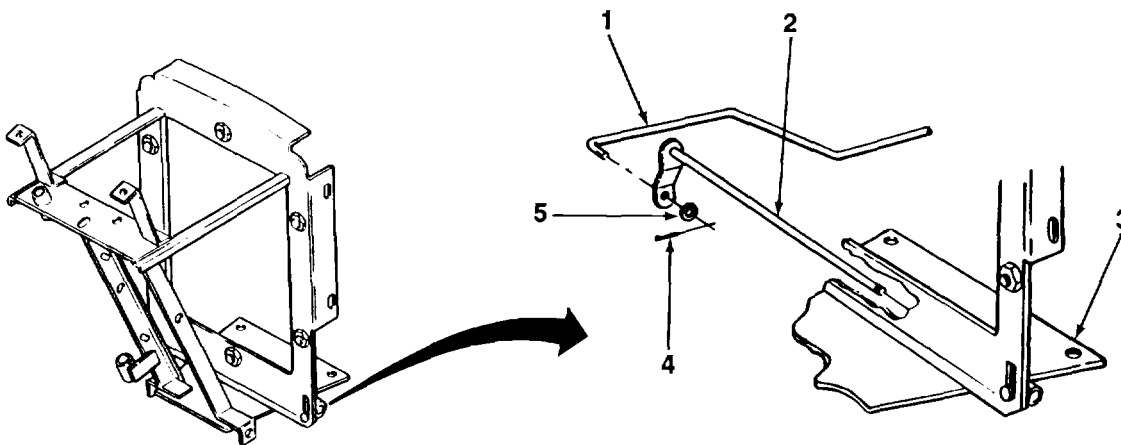

TA701331

5-5. SPEED CONTROL SHAFT REPLACEMENT (Con't).

b. CLEANING AND INSPECTION**WARNING**

Dry cleaning solvent, P-D-680, is toxic and flammable. Always wear protective goggles and gloves, and use only in a well-ventilated area. Avoid contact with skin, eyes, and clothes, and DO NOT breathe vapors. DO NOT use near open flame or excessive heat. The solvent's flash point is 100°F-138°F (38°C-59°C). If you become dizzy while using cleaning solvent, immediately get fresh air and medical help. If solvent contacts eyes, immediately wash your eyes and get medical aid.

1. Clean speed control shaft with dry cleaning solvent. Wipe dry with clean, dry rags.
2. Inspect speed control shaft for cracks, breaks, abnormal bends, and excessive wear at cowl support contact points. Replace if defective.

c. INSTALLATION

1. Apply grease to cowl support contact points on speed control shaft (2).
2. Slide speed control shaft (2) in cowl support (3).
3. Install speed control rod (1), washer (5), and new cotter pin (4) in speed control shaft (2).

FOLLOW-ON TASKS:

- Install cowl support (see paragraph 13-5).
- Install speed control arms (see TM 5-2420-222-20).

5-19/(5-20 Blank)

**CHAPTER 6
COOLING SYSTEM MAINTENANCE**

6-1. RADIATOR REPAIR.

For information on radiator repair, refer to TM 750-254.

6-1/(6-2 Blank)

**CHAPTER 7
ELECTRICAL SYSTEM MAINTENANCE**

Paragraph Number	Paragraph Title	Page Number
7-1	Engine AC Generator Repair	7-1
7-2	Engine Starter Repair.....	7-14

7-1. ENGINE AC GENERATOR REPAIR.

This Task Covers:

- | | |
|----------------------------|-------------|
| a. Disassembly | d. Assembly |
| b. Cleaning and Inspection | e. Test |
| c. Repair | |

Initial Setup:

Equipment Conditions:

- AC generator pulley removed (see TM 5-2420-222-20).
- AC generator removed (see TM 5-2420-222-20).
- Voltage regulator removed (see TM 5-2420-222-20).

Materials/Parts:

- Soldering flux (Item 16, Appendix B)
- Fine abrasive paper (Item 27, Appendix B)
- Rags (Item 28, Appendix B)
- Tin alloy solder (Item 30, Appendix B)
- Trichlorotrifluoroethane (Item 40, Appendix B)
- Insulating varnish (Item 42, Appendix B)
- One preformed packing

Tools/Test Equipment:

- Automotive fuel and electrical tool kit
- Electrical repair shop set
- Automotive generator and starter test stand

References:

- TM 5-2420-222-20
- TM 9-214

General Safety Instructions:

- Trichlorotrifluoroethane cleaning compound is highly flammable and toxic, and must not be used near open flame. Use only in a well-ventilated area.
- Insulating varnish is toxic and flammable. Wear safety goggles and gloves, and use only in areas of forced ventilation.
- Compressed air used for cleaning purposes should never exceed 30 psi (207 kPa).

7-1. ENGINE AC GENERATOR REPAIR (Con't).

NOTE

Loader backhoes with serial numbers 235786-235999 have 55-amp AC generators. Loader backhoes with serial numbers 319995-342573 have 35-amp AC generators. Both AC generators are maintained the same way. 35-amp AC generator for loader backhoes with serial numbers 319995-342573 is shown, except as noted.

a. DISASSEMBLY

1. Remove two screws (1), cover (2), and brush assembly (3) from rear electrical end bell (4).
2. Remove four bolts (7) and square nuts (6) from front and rear electrical end bells (5 and 4).

CAUTION

Do not allow tools to touch generator stator. Contact could damage protective coating.

3. Using machinist's scriber, match-mark front and rear electrical end bells (5 and 4).

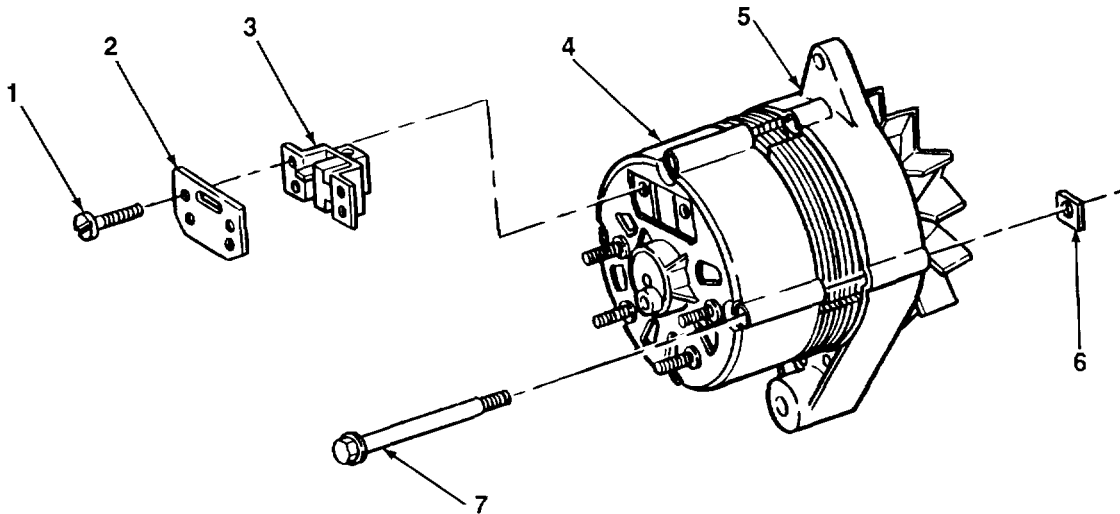

4. Position front electrical end bell (5) in vise with caps. Pry rear electrical end bell (4) and assembled parts off front electrical end bell and rotor (15).
5. Remove two nuts (8) and washer insulators (9) from rear electrical end bell (4) and two terminal studs (11). Remove plate assembly (21).
6. Remove two nuts (10) from rear electrical end bell (4) and two terminal studs (18). Push two semiconductor devices (13 and 17) with assembled parts out of rear electrical end bell.
7. Remove two special spacers (20) and washer insulators (19) from two semiconductor devices (13 and 17).

TA701332

7-1. ENGINE AC GENERATOR REPAIR (Con't).

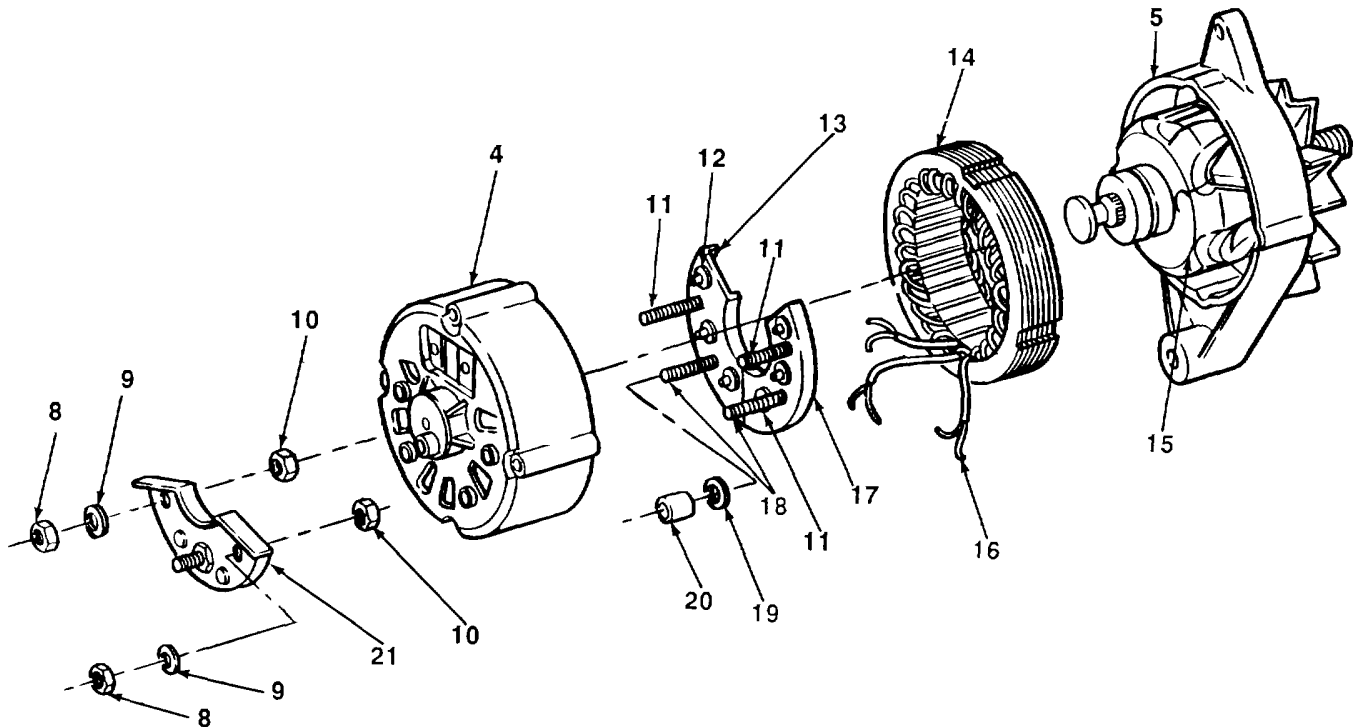
**CAUTION**

Do not twist or bend terminals. Twisting or bending may damage parts. Use long nose pliers as a heat sink to prevent damage to semiconductor devices while unsoldering stator lead terminals.

NOTE

Do not remove stator lead terminals unless damaged. All six stator lead terminals are unsoldered the same way. One terminal and semiconductor device is shown. Repeat step 8 for remaining terminals and semiconductor devices.

8. Using soldering gun and long nose pliers, unsolder stator lead terminal (16) and diode (12) from semiconductor device (13).
9. Remove stator (14) from two semiconductor devices (13 and 17).

TA701333

7-1. ENGINE AC GENERATOR REPAIR (Con't).

10. Remove fan (26) and sleeve bushing (25) from rotor (15).
11. Remove retaining ring (23) from front electrical end bell (5) and ball bearing (24) with bent tip long nose pliers
12. Position front electrical end bell (5) upside down on wood block. Tap rotor (15) with assembled parts out of front electrical end bell.
13. Using mechanical gear and bearing puller, remove ball bearing (24) from front electrical end bell (5).
14. Using mechanical gear and bearing puller, remove ball bearing (22) from rotor (15).

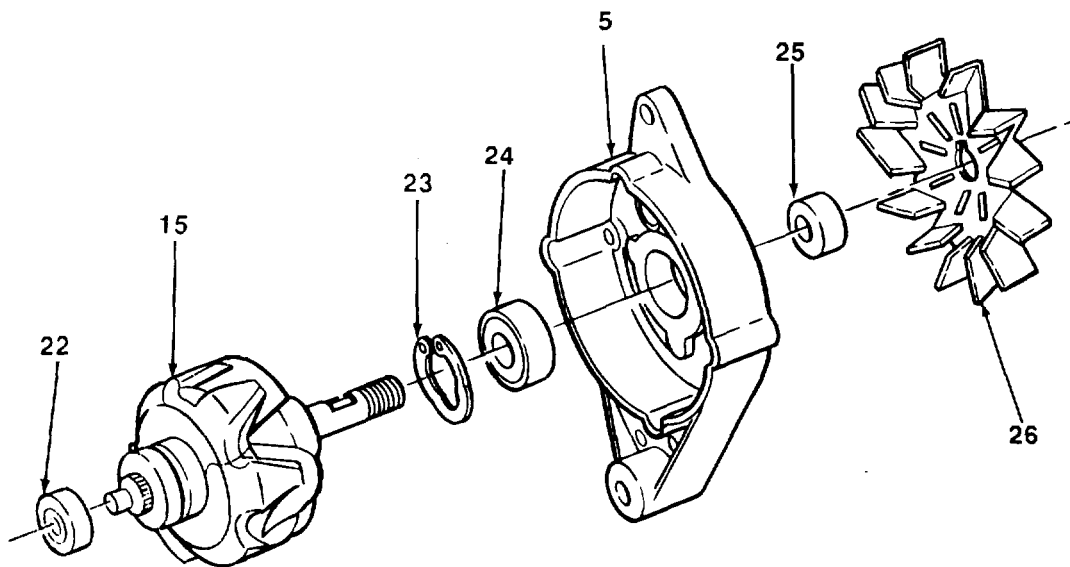

TA701334

7-1. ENGINE AC GENERATOR REPAIR (Con't).

15. Remove preformed packing (27) from rear electrical end bell (4). Discard preformed packing.

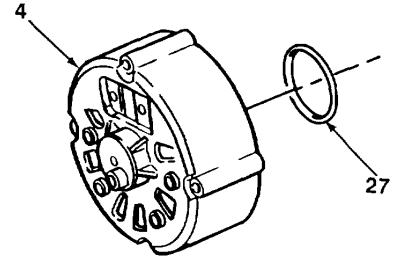
**b. CLEANING AND INSPECTION****WARNING**

Cleaning compound, trichlorotrifluoroethane, for electrical parts is toxic and flammable, and reacts violently with aluminum, titanium, barium, lithium, samarium, sodium, and potassium. Always wear protective goggles and rubber gloves, and use only in a well-ventilated area. DO NOT wear jewelry while using cleaning compound. Avoid contact with skin, eyes, and clothes, and DO NOT breathe vapors. Cleaning compound fumes or vapors can take the place of air and may become a cancer producing agent. DO NOT use near open flame or excessive heat. The compound's boiling point is 114°F (46°C). If you become dizzy while using cleaning compound, immediately get fresh air and medical help. If compound contacts eyes, immediately wash your eyes with water and get medical aid.

1. Clean all metal and nonmetallic parts except ball bearings with trichlorotrifluoroethane and a rag. Dry parts thoroughly with clean, dry rags.
2. Clean and inspect two ball bearings (see TM 9-214).

TA701335

7-1. ENGINE AC GENERATOR REPAIR (Con't).

WARNING

Compressed air used for cleaning or drying purposes, or for clearing restrictions should never exceed 30 psi (207 kPa). Wear protective clothing (goggles/shield, gloves, etc.) and use caution to avoid injury to personnel.

3. Using fine abrasive paper, clean two slip rings (28 and 29) on rotor (15). Remove loose particles with compressed air.
4. Inspect all metal parts for cracks, breaks, abnormal bends, and burrs. Replace all defective parts.
5. Inspect all threaded parts for damaged threads. Replace all damaged parts.
6. Measure length of exposed brushes (31 and 32) of brush assembly (3). Exposed length must be $\frac{1}{4}$ in. (6.35 mm) or more.
7. Using multimeter, check terminal (30) and brush (32) for open circuit. No open circuit is allowed.
8. Using multimeter, check housing (33) and brush (31) for open circuit. No open circuit is allowed.
9. Using multimeter, check for improper grounding between housing (33) and terminal (30). No continuity is allowed.

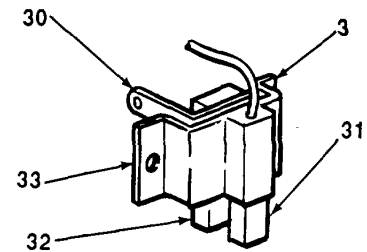
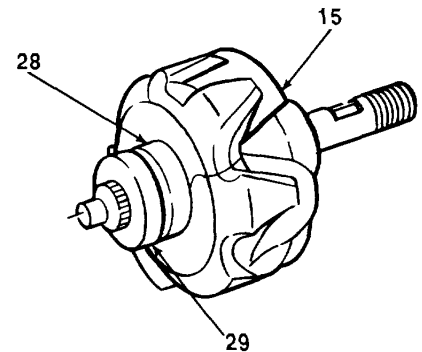

TA701336

7-1. ENGINE AC GENERATOR REPAIR (Con't).

NOTE

Semiconductor device diodes can be checked with or without stator connecting leads soldered in place.

10. Using multimeter, check diodes (12) for high and low impedance readings. If high or low readings are identical for all six diodes, semiconductor device (13 or 17) is okay. If readings vary slightly, semiconductor devices are defective and should be replaced.

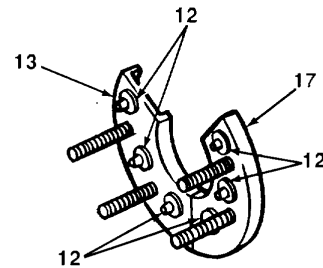

NOTE

Loader backhoes with serial numbers 235786-235999 have Wye-connected stator circuits. Loader backhoes with serial numbers 319995-342573 have Delta-connected stator circuits.

11. Inspect windings (39) on stator (14 for shorts and damaged or burned insulation.

NOTE

Steps 12 through 16 apply only to loader backhoes with serial numbers 235786-235999.

12. Using soldering gun and long round nose pliers, unsolder and separate three winding ends (34, 36, and 38) on stator (14).

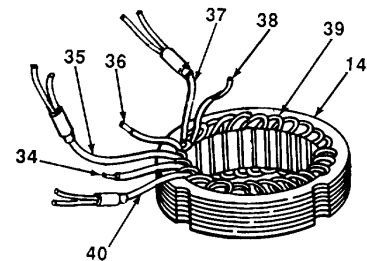

SERIAL NUMBERS 235786-235999

13. Using multimeter, check for continuity between six winding ends (34 and 40, 35 and 36, and 37 and 38). If open circuit is present, stator (14) is defective and must be replaced.
14. Using multimeter check for continuity between stator (14) and three winding ends (34, 36, and 38). If continuity or grounded winding exists, stator is defective and must be replaced.
15. Using multimeter, check for continuity between winding ends (34 and 36, 36 and 38, and 34 and 38). If continuity or short exists between winding (34, 36, and 38), stator (14) is defective and must be replaced.
16. Using soldering gun and long nose pliers, twist and solder together three windings (34, 36, and 38).

TA701337

7-1. ENGINE AC GENERATOR REPAIR (Con't).**NOTE**

Steps 17 through 22 apply only to loader back hoes with serial numbers 319995-342573.

17. Using soldering gun and long round nose pliers, unsolder and separate three connecting leads (41, 44, and 47) and six winding ends (43, 45, 46, 48, 49, and 42) on stator (14).
18. Using multimeter, check for continuity between winding ends (42 and 46, 43 and 48, and 45 and 49). If open circuit exists, stator (14) is defective and must be replaced.
19. Using multimeter, check for continuity between stator (14) and three winding ends (46, 48, and 49). If continuity or grounded winding exists, stator is defective and must be replaced.
20. Using multimeter, check for continuity between winding ends (46 and 48, 46 and 49, and 48 and 49). If continuity or short exists between windings (46, 48, and 49), stator (14) is defective and must be replaced.

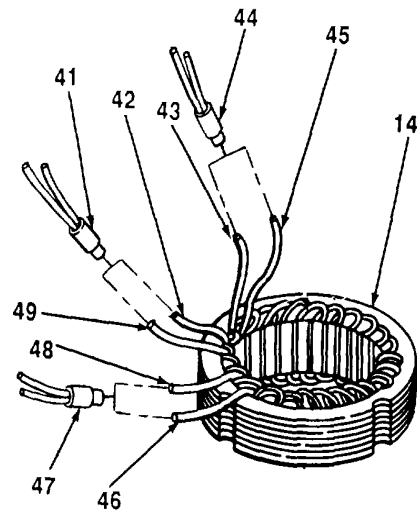

SERIAL NUMBERS 319995-342573

21. Using long round nose pliers and soldering gun, twist and solder together two windings ends (46 and 48) and connecting lead (47).
22. Repeat step 21 for winding ends (42 and 49) and connecting lead (41), and winding ends (43 and 45) and connecting lead (44).
23. Using automotive generator and starter test stand, check two slip rings (28 and 29) on rotor (15) for field current draw.
 - (a) For loader backhoes with serial numbers 235786-235999, rotor field current draw should be 1.85-2.25 amp at 10 v when surrounding air temperature is 75°F (24°C).
 - (b) For loader backhoes with serial numbers 319995-342573, rotor field current draw should be 2.0-2.6 amp at 10 v when surrounding air temperature is 75°F (24°C).

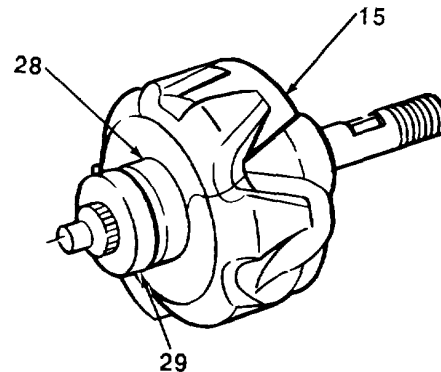

24. If field current draw is too high, windings are shorted and rotor (15) is defective. If no field current draw exists, windings are open and rotor is defective.
25. Using multimeter, check two slip rings (28 and 29) on rotor (15) for field circuit resistance.
 - (a) For loader backhoes with serial numbers 235786-235999, resistance should be 5.0 ohms.
 - (b) For loader backhoes with serial numbers 319995-342573, resistance should be 4.0-5.5 ohms.

TA701338

7-1. ENGINE AC GENERATOR REPAIR (Con't).**c. REPAIR**

1. If scored, turn slip rings on rotor using engine lathe, then polish lightly with fine abrasive paper.
2. Restore damaged rotor, semiconductor devices, or plate assembly threads using screw threading set.

d. ASSEMBLY

1. Using arbor press and inside diameter remover and installer, press ball bearing (22) in place on rotor (15).
2. Using arbor press and outside diameter remover and installer, press ball bearing (24) in front electrical end bell
3. Install retaining ring (23) against ball bearing (24) in front electrical end bell (5).
4. Position front electrical end bell (5) on wood blocks with ball bearing (24) facing up. Install rotor (15) with assembled parts in ball bearing and tap until seated.
5. Slide sleeve bushing (25) in place against ball bearing (24) on rotor (15).
6. Install fan (26) on rotor (15).

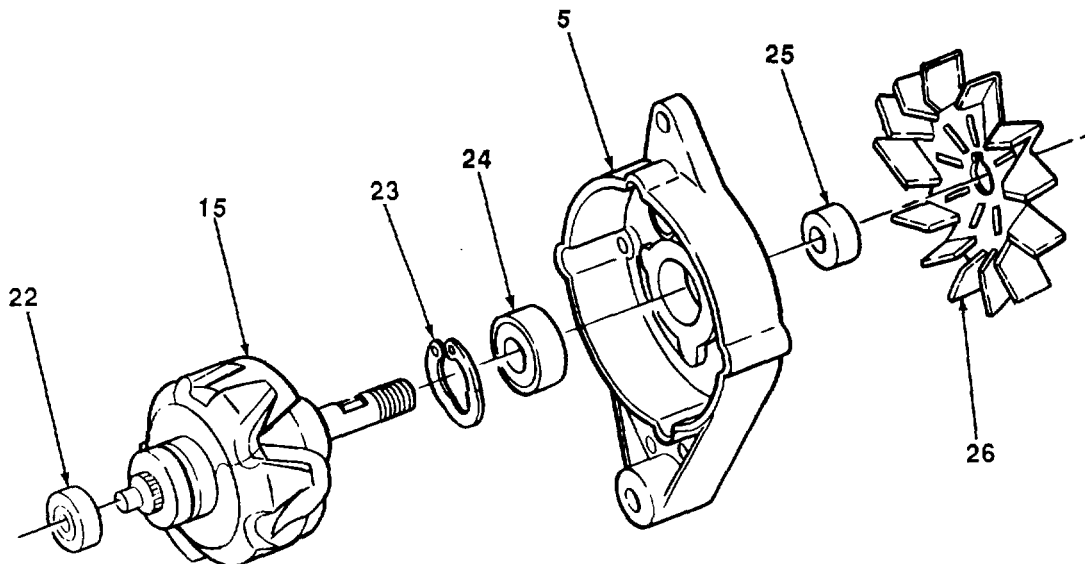

TA71339

7-1. ENGINE AC GENERATOR REPAIR (Con't).

7. Position stator (14) in place on two semiconductor devices (13 and 17).

CAUTION

Do not twist or bend terminals. Twisting or bending terminals may damage parts. Use long round nose pliers as a heat sink to prevent damage to semiconductor devices while soldering stator lead terminals.

NOTE

If stator lead terminals have not been unsoldered, skip steps 8 and 9. All six stator lead terminals are soldered the same way. One stator lead terminal and semiconductor device is shown. Repeat steps 8 and 9 for remaining connections.

8. Using soldering gun and long round nose pliers, solder stator lead terminal (16) and diode (12) on semiconductor device (13). Allow solder connection to cool.

WARNING

Insulating varnish is toxic and flammable. Boiling point is 230°F (110°C). Wear protective goggles and gloves, and use only in areas with forced ventilation. Avoid contact with skin, eyes, and clothes, and do not breathe vapors. Do not use near open flame or excessive heat. If you become dizzy while using insulating varnish, get fresh air immediately and get medical aid. If contact with eyes is made, wash your eyes with water and get medical aid immediately. If swallowed, do not induce vomiting and get medical aid immediately.

9. Use a paint brush to apply insulating varnish to solder connection between stator lead terminal (16) and diode (12).

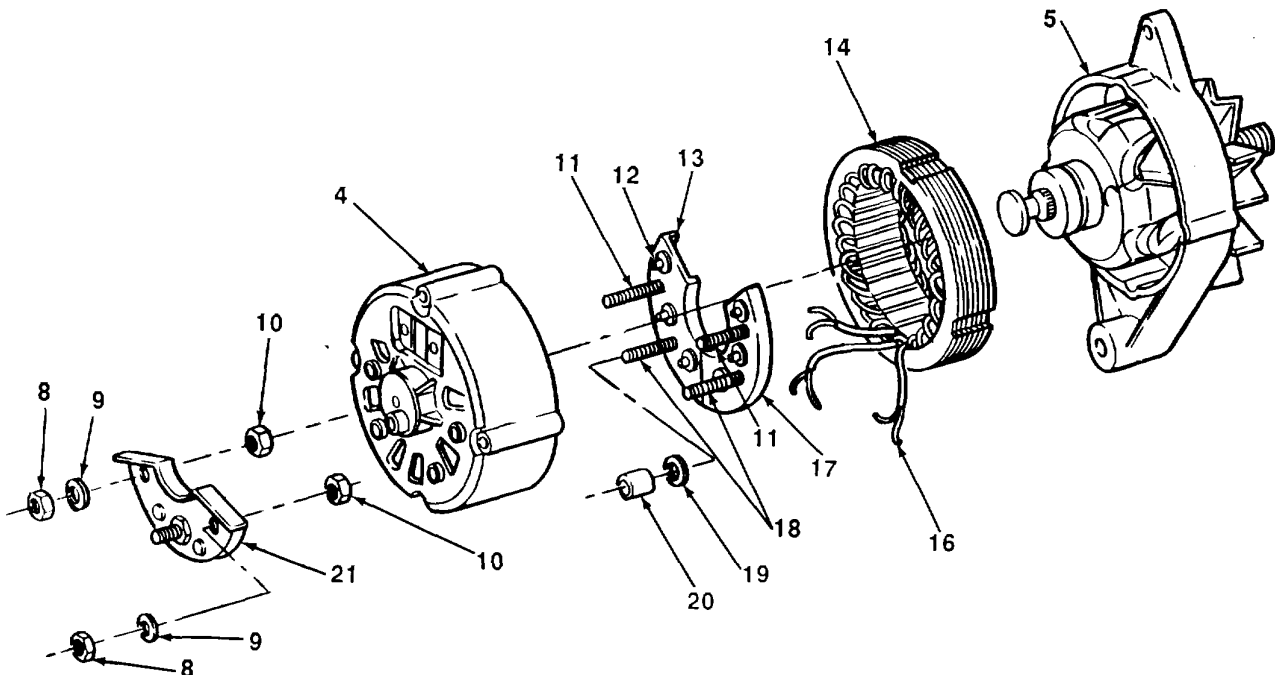

7-1. ENGINE AC GENERATOR REPAIR (Con't).

10. Install new preformed packing (27) in rear electrical end bell (4).
11. Install two special spacers (20) and washer insulators (19) on terminal studs (18).
12. Install two semiconductor devices (13 and 17) with assembled parts in rear electrical end bell (4). Install two nuts (10) on terminal studs (18) and rear electrical end bell.
13. Install plate assembly (21) with two nuts (8) and washer insulators (9) on rear electrical end bell (4) and two terminal studs (11).
14. Position rear electrical end bell (4) in place on front electrical end bell (5) and aline match-marks.
15. Install four bolts (7) and square nuts (6) in front and rear electrical end bells (5 and 4).

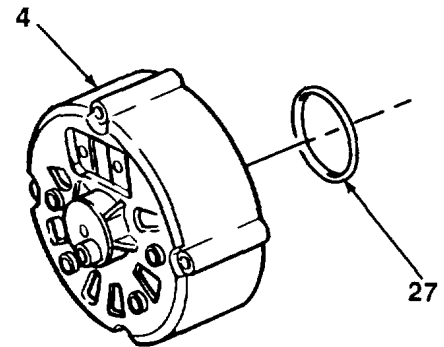

NOTE

For loader backhoes with serial numbers 235786-235999, perform step 17. For loader backhoes with serial numbers 319995-342573, perform step 18.

16. Torque bolts (7) and square nuts (6) evenly to 50-59 lb.-in. (5.7-6.7 N•m).
17. Torque bolts (7) and square nuts (6) evenly to 26-28 lb.-in. (2.9-3.2 N•m).
18. Install brush assembly (3) and cover (2) in place on rear electrical end bell (4). Install two screws (1) to secure brush assembly to rear electrical end bell.
19. Install voltage regulator (see TM 5-2420-222-20).

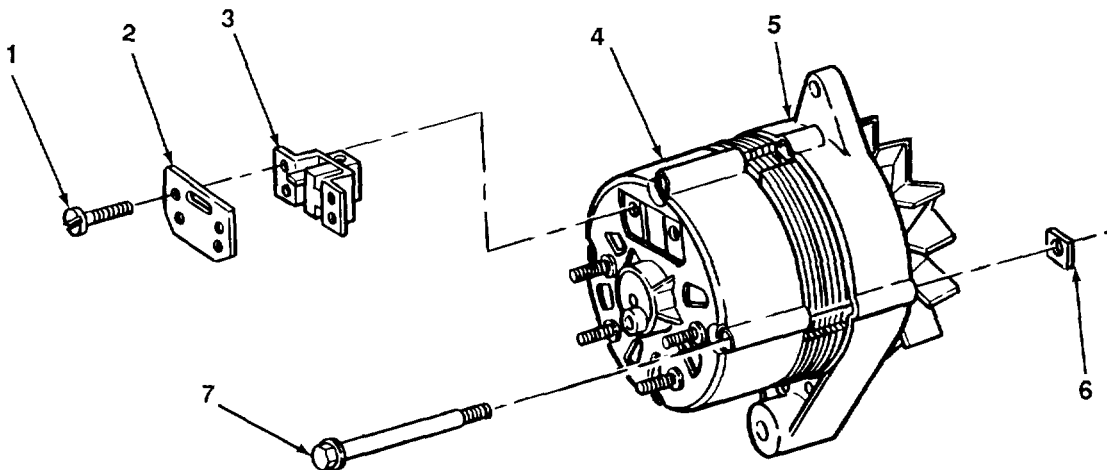

TA701341

7-1. ENGINE AC GENERATOR REPAIR (Con't).**e. TEST**

1. Install AC generator (50) in automotive generator and starter test stand.
2. Connect automotive generator and starter test stand jumper wire (54) between output terminal (53) and regulator terminal (55) to excite field circuit of AC generator (50).

NOTE

For loader backhoes with serial numbers 235786-235999 (55-amp AC generators), run at 1660 rpm. For loader backhoes with serial numbers 319995-342573 (35-amp AC generators), run at 1180 rpm.

3. Adjust automotive generator and starter test stand variable resistor to obtain proper voltage and check output.
 - (a) For loader backhoes with serial numbers 235786-235999, output at 1660 rpm should be at least 23 amp at 13-15 v with ambient temperature of 75°F (24°C).
 - (b) For loader backhoes with serial numbers 319995-342573, output at 1180 rpm should be at least 5 amp at 13-15 v with ambient temperature of 77°F (25°C).
4. Run at 3000 rpm and check output.
 - (a) For loader backhoes with serial numbers 235786-235999, output at 3000 rpm should be at least 45 amp at 13-15 v with ambient temperature of 75°F (24°C).
 - (b) For loader backhoes with serial numbers 319995-342573, output at 3000 rpm should be at least 26 amp at 13-15v with ambient temperature of 77°F (25°C).

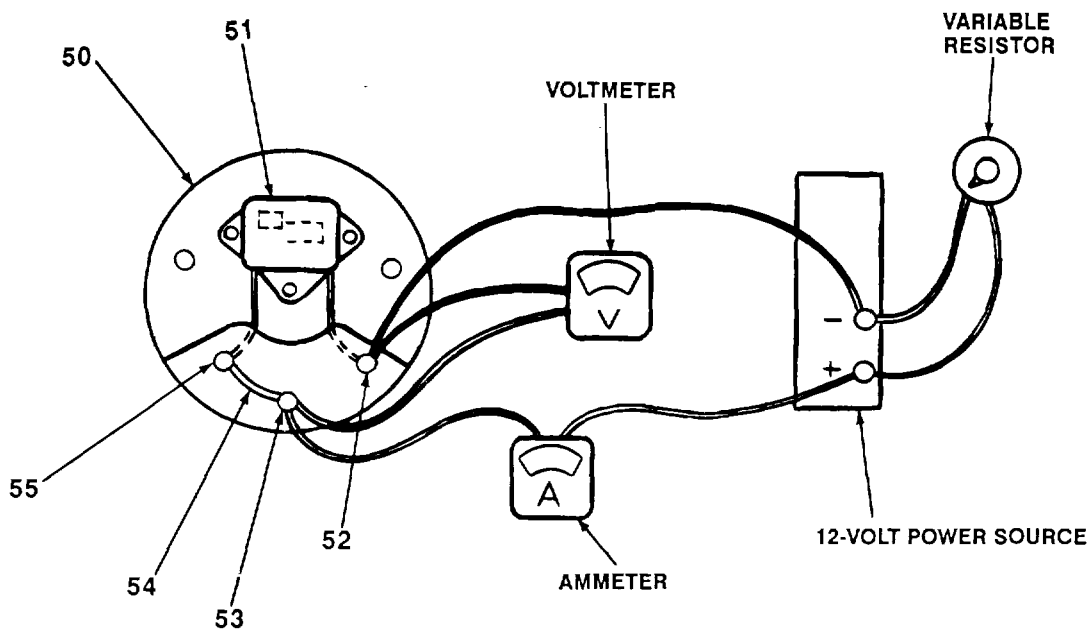

TA701342

7-1. ENGINE AC GENERATOR REPAIR (Con't).

5. Remove automotive generator and starter test stand jumper wire (54) from output terminal (53) and regulator terminal (55) on AC generator (50).
6. Connect automotive generator and starter test stand voltmeter to output terminal (53) and ground terminal (52).
7. Open automotive generator and starter test stand variable resistor and check voltage regulator operation. Voltage regulator (51) should maintain AC generator output voltage from 13-15 v.
8. Disconnect automotive generator and starter test stand voltmeter from output terminal (53) and ground terminal (52).
9. Remove AC generator (50) from automotive generator and starter test stand.

FOLLOW-ON TASKS:

- Install AC generator pulley (see TM 5-2420-222-20).
- Install AC generator (see TM 5-2420-222-20).

7-2. ENGINE STARTER REPAIR.*This Task Covers:*

- | | |
|----------------------------|-------------|
| a. Disassembly | d. Assembly |
| b. Cleaning and Inspection | e. Test |
| c. Repair | |

*Initial Setup:***Equipment Conditions:**

- Starter removed (see TM 5-2420-222-20).

Tools/Test Equipment:

- Automotive fuel and electrical tool kit
- Electrical repair shop set
- Automotive generator and starter test stand

General Safety Instructions:

- Trichlorotrifluoroethane cleaning compound is highly flammable and toxic, and must not be used near open flame. Use only in a well-ventilated area.
- Insulating varnish is toxic and flammable. Wear protective goggles and gloves, and use only areas with forced ventilation.
- Compressed air used for cleaning purposes should never exceed 30 psi (207 kPa).

Materials/Parts:

- Soldering flux (Item 16, Appendix B)
- Engine oil item 25, Appendix B)
- Fine abrasive paper (Item 27, Appendix B)
- Rags (Item 28, Appendix B)
- Tin alloy solder (Item 30, Appendix B)
- Marker tags (Item 32, Appendix B)
- Masking tape (Item 38, Appendix B)
- Trichlorotrifluoroethane (Item 40, Appendix B)
- Insulating varnish (Item 42, Appendix B)
- One gasket
- One retaining ring
- One self-locking bolt
- One spring pin
- Thirteen lockwashers

a. DISASSEMBLY

1. Using machinist's scriber, match-mark electrical end bell (5) and drive housing (1) with main housing (2).
2. Remove screw (4) and lockwasher (3) from angle bracket (6) and electromagnetic relay (7). Discard lockwasher.

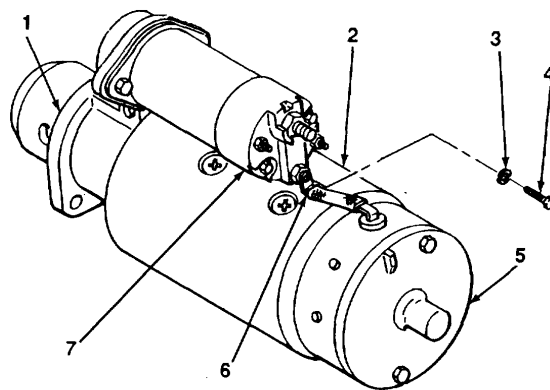

7-2. ENGINE STARTER REPAIR (Con't).

3. Remove two capscrews (8) and electrical end bell (5) with assembled parts from drive housing (1).
4. Remove main housing (2) and angle bracket (6) from electromagnetic relay (7), drive housing (1), and armature (9) with assembled parts.

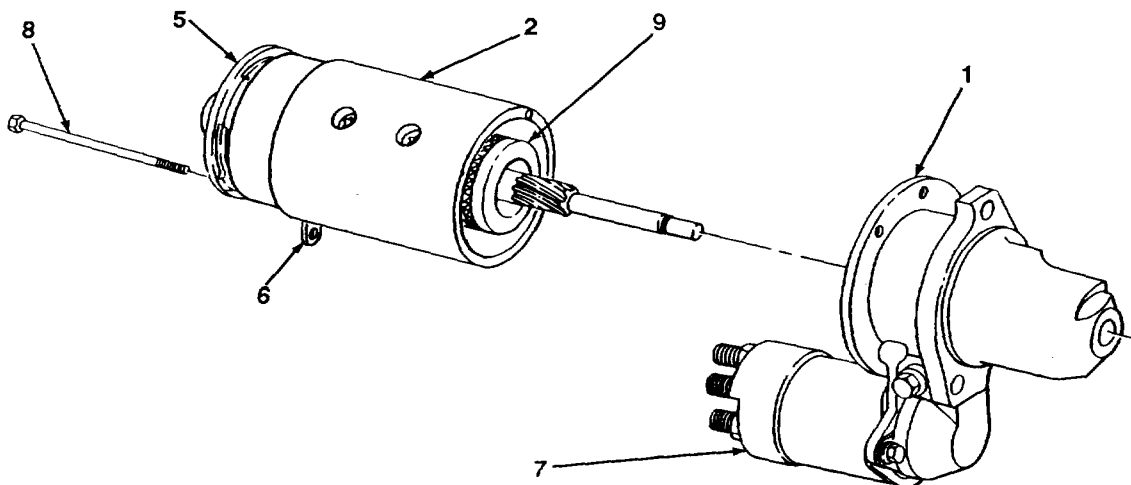

WARNING

Spring on electromagnetic relay is under pressure. Hold relay to prevent sudden release. Parts can fly out and injure personnel.

5. Remove two machine screws (19) and lockwashers (18) from electromagnetic relay (7) and drive housing (1). Discard lockwashers.
6. Remove electromagnetic relay (7), spring (16), and gasket (17) from drive housing (1). Discard casket.

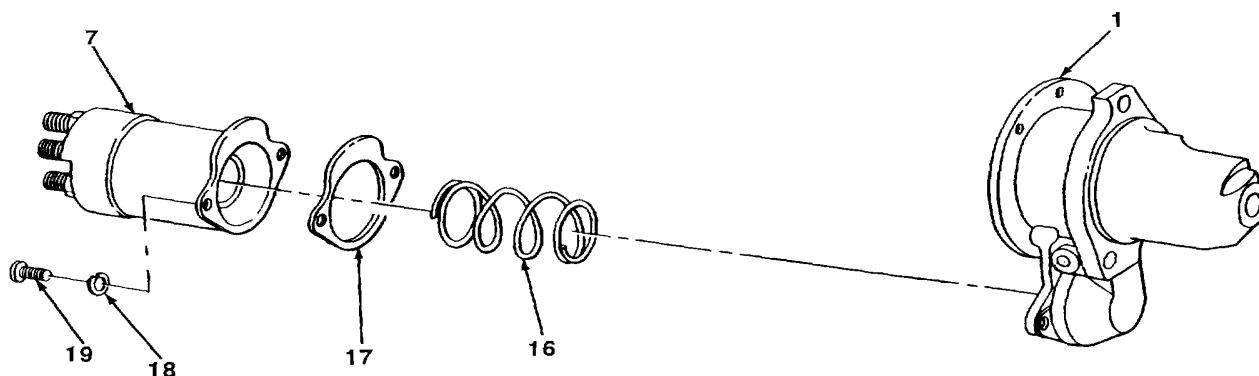

7-2. ENGINE STARTER REPAIR (Con't).

7. Remove capscrew (14), lockwasher (12), and nut (13) from drive housing (1) and shifter fork (11) with assembled parts. Discard lockwasher.
8. Remove armature (9) with assembled parts from drive housing (1).
9. Remove shifter fork (11) and solenoid plunger (15) off drive (10) and armature (9).

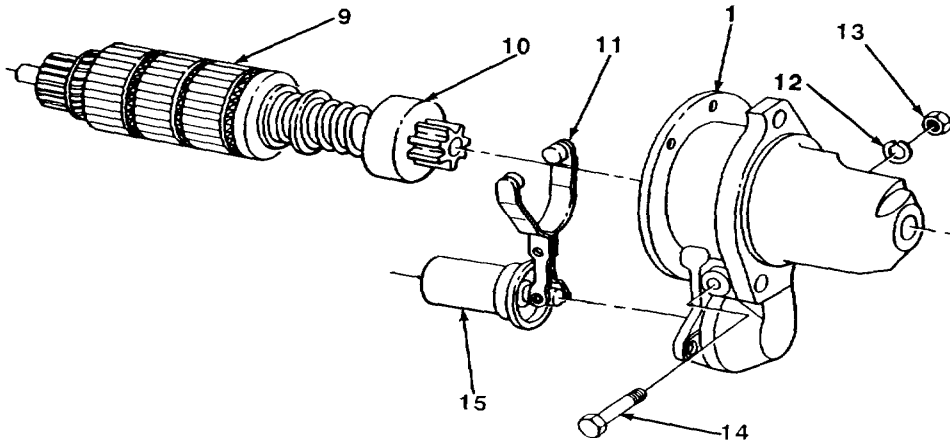

10. Remove ring spacer (20) from electrical end bell side of armature (9). Remove drive end thrust collar (25), retaining ring (24), and ring spacer (23) from drive (10) and armature. Discard retaining ring.
11. Using arbor press, remove drive (10) from armature (9). Remove flatwasher (22) and ball bearing (21) from armature.
12. Position solenoid plunger (15) in vise. Drive spring pin (26) out of solenoid plunger and shifter fork (11). Remove shifter fork from solenoid plunger. Remove solenoid plunger from vise. Discard spring pin.

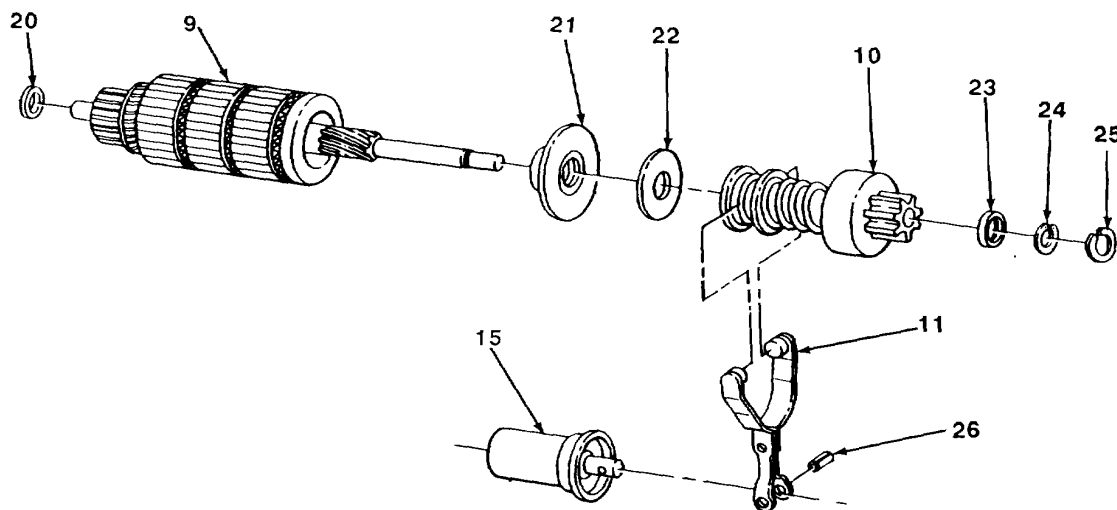

TA701345

7-2. ENGINE STARTER REPAIR (Con't).

13. Pry two pins (36) out of four brush holders (35 and 37) and two supports (30). Remove four brush holders and two springs (31) from two supports.
14. Remove two drive screws (27), lockwashers (28), leads (29), and brushes (38) from brush holders (37). Discard lockwashers.
15. Remove two drive screws (33), lockwashers (34), leads (29), and brushes (32) from brush holders (35). Discard lockwashers.

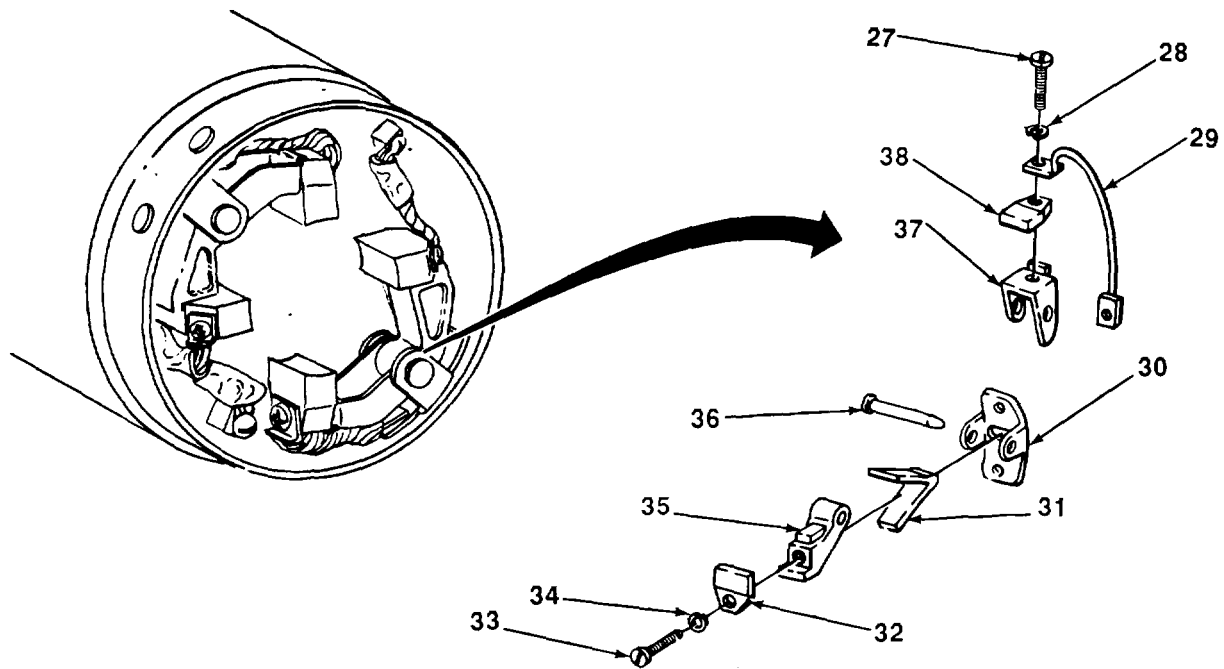

7-2. ENGINE STARTER REPAIR (Con't).

16. Remove self-locking bolt (44), lockwasher (43), two wire terminals (45), and angle bracket (6) with grommet (42) from main housing (2). Remove grommet from angle bracket. Discard self-locking bolt and lockwasher.

CAUTION

Do not remove coil, pole pieces, and retaining screws unless damaged. Be careful when handling these parts. Scraping Insulating varnish from coil assembly could cause grounding to main frame or pole shoes, or shorted windings.

NOTE

If not removing coil, pole pieces, and retaining screws, skip steps 17 and 18.

17. Remove eight machine screws (41) from main housing (2) and four pole pieces (40)
18. Remove coil (39) and four pole pieces (40) from main housing (2). Remove pole pieces from coil.

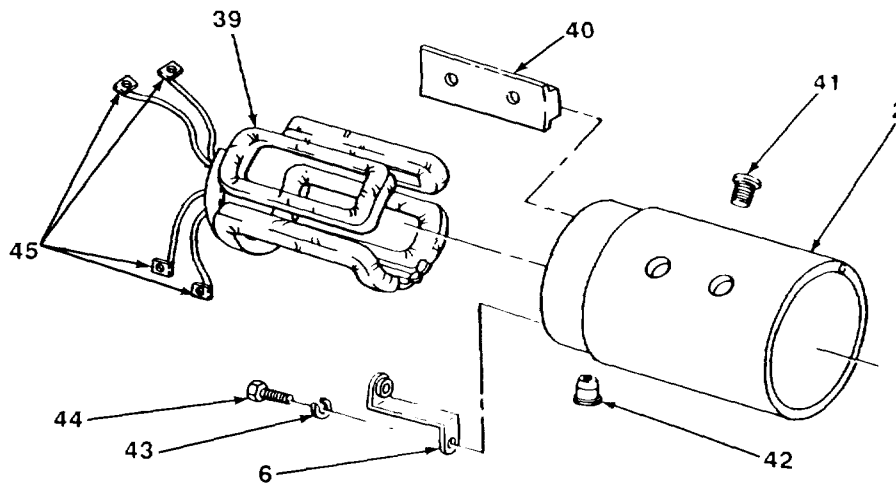
**CAUTION**

Do not remove riveted support unless damaged. Removal will damage rivets.

NOTE

- Some supports and leads are secured with rivets, some with screws, lockwashers, and nuts. If parts are secured with rivets, perform step 19. If parts are secured with screws, lockwashers, and nuts, skip step 19 and perform step 20.
- Supports and leads having rivets will use screws, lockwashers, and nuts for assembly.

19. Using portable electrical drill, drill out four rivets (52) from main housing (2), two supports (30), and leads (29). Discard rivets.

7-2. ENGINE STARTER REPAIR (Con't).

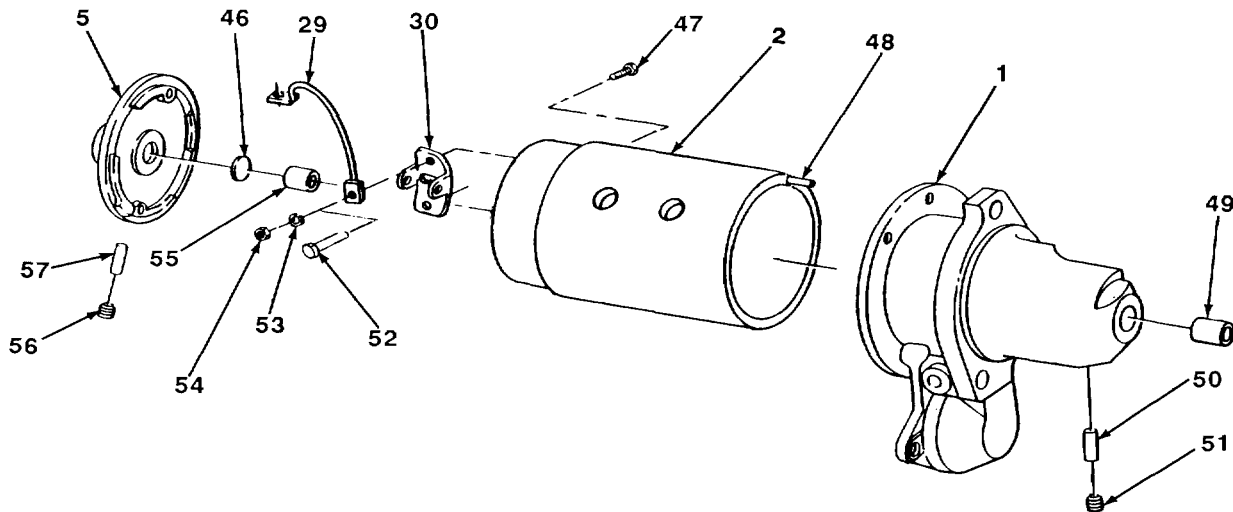

20. Remove four screws (47), lockwashers (53), and nuts (54) from main housing (2), two supports (30), and leads (29). Discard lockwashers.
21. Remove two supports (30) and leads (29) from main housing (2).
22. Remove wick end (46) from electrical end bell (5).

NOTE

Some loader backhoes do not have pipe plug and wick.

23. Remove pipe plug (56) and wick (57) from electrical end bell (5).

CAUTION

Do not remove sleeve bushing unless damaged. Removal may damage parts.

24. Using gear and bearing mechanical puller, remove sleeve bushing (55) from electrical end bell (5).
25. Remove pipe plug (51) and wick (50) from drive housing (1).

CAUTION

Do not remove sleeve bushing or straight pin unless damaged. Removal may damage parts.

26. Using arbor press and inside diameter remover and installer, drive out sleeve bushing (49) from drive housing (1).
27. Remove straight pin (48) from main housing (2).

TA701348

7-2. ENGINE STARTER REPAIR (Con't).**b. CLEANING AND INSPECTION****WARNING**

Cleaning compound, trichlorotrifluoroethane, for electrical parts is toxic and flammable, and reacts violently with aluminum, titanium, barium, lithium, samarium, sodium, and potassium. Always wear protective goggles and rubber gloves, and use only in a well-ventilated area. DO NOT wear Jewelry while using cleaning compound. Avoid contact with skin, eyes, and clothes, and DO NOT breathe vapors. Cleaning compound fumes or vapors can take the place of air and may become a cancer producing agent. DO NOT use near open flame or excessive heat. The compound's boiling point is 114°F (46°C). If you become dizzy while using cleaning compound, immediately get fresh air and medical help. If compound contacts eyes, immediately wash your eyes with water and get medical aid.

1. Clean all metal and nonmetallic parts except ball bearings with trichlorotrifluoroethane and clean rags. Dry parts thoroughly with clean dry rags.

WARNING

Compressed air used for cleaning or drying purposes or for clearing restrictions, should never exceed 30 psi (207 kPa). Wear protective clothing (goggles/shield, gloves, etc.) and use caution to avoid injury.

2. Using fine abrasive paper, clean surface of commutator on armature. Remove loose particles with compressed air.
3. Inspect all metal parts for cracks, breaks, burns, wear, and abnormal bends. Replace defective parts.
4. Inspect all threaded parts for damaged threads.
5. Check wicks for fraying or wear.
6. Inspect two brush springs for discoloration. Using portable spring resiliency tester, check spring for weakness. Spring tension must be at least 35 oz (9.7 N). Replace both brush springs if either spring does not meet specification.
7. Inspect four brushes for cracks and breaks. Measure length of brushes. Brushes must be at least Y6 in. long.
8. Inspect drive housing sleeve bushing for looseness in bore, wear, scoring, and grooves. Using telescoping gages, measure inside diameter of sleeve bushing in three places. Correct inside diameter is 0.499-0.511 in. (12.675-12.979 mm).
9. Inspect electrical end bell sleeve bushing for looseness in bore, wear, scoring, and grooves. Using telescoping gages, measure inside diameter of sleeve bushing. Correct inside diameter is 0.563-0.573 in. (14.300-14.554 mm).
10. Using outside micrometer caliper, measure armature end bushing contact area in three places. Difference between largest armature end bushing inside diameter and smallest armature end shaft outside diameter must not exceed 0.017 in. (0.432 mm) oil clearance.
11. Using outside micrometer caliper, measure electrical end bell bushing contact area in three places. Difference between largest electrical end bell bushing inside diameter and smallest electrical end bell shaft outside diameter must not exceed 0.016 in. (0.406 mm) oil clearance.

7-2. ENGINE STARTER REPAIR (Con't).**CAUTION**

Do not touch commutator brush surface or shaft bearing surface with test probes. This may cause arcing which could damage surfaces.

12. Inspect commutator (58) for roughness, burrs, pitting, burning, and loose solder joints.
13. Using V-blocks and dial indicator, check commutator for high mica. Undercut depth must be 0.031 in. (0.787 mm).
14. Using armature test set, check commutator for short circuits and open or grounded windings. Short circuits and open or grounded windings are not allowed.
15. Inspect coil for frayed, worn, and damaged insulation. Using multimeter, check coil for open circuit. No open circuit is allowed.

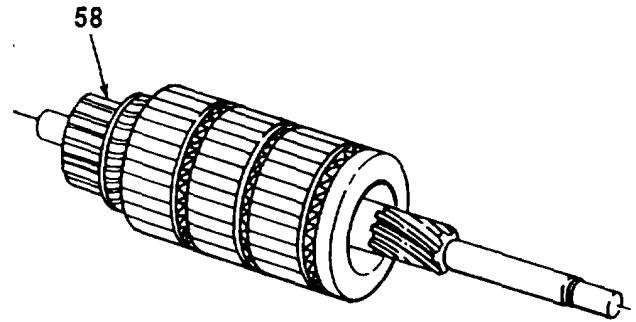

16. Using multimeter, check for grounding between main housing and coil. No continuity between main housing and coil is allowed. Ground may be caused by worn insulation or metal particles trapped between coil and main housing.
17. Rotate drive pinion in both directions. Pinion should rotate smoothly with slight drag in one direction and lock up in the other direction.

c. REPAIR

1. Restore any damaged threads using screw threading set.
2. Remove rough or burred areas on commutator (58) using fine abrasive paper. Commutator should be smooth and shiny.
3. Using soldering gun and tin alloy solder, solder loose solder joints or open windings on commutator (58).
4. If commutator (58) is out-of-round, turn commutator down on lathe until round and smooth.
5. If mica clearance is less than allowed, undercut mica to depth of 0.031 in. (0.787 mm) using electrically operated armature mica undercuts.
6. If short circuit is found in commutator (58), clean grooves between bars.

TA701349

7-2. ENGINE STARTER REPAIR (Con't).**WARNING**

Insulating varnish is toxic and flammable. Boiling point is 230°F (110°C). Wear protective goggles and gloves, and use only in areas with forced ventilation. Avoid contact with skin, eyes, and clothes, and do not breathe vapors. Do not use near open flame or excessive heat. If you become dizzy while using insulating varnish, get fresh air immediately and get medical aid. If contact with eyes is made, wash your eyes with water and get medical aid immediately. If swallowed, do not induce vomiting and get medical aid immediately.

7. If coil insulation is frayed, worn, or damaged, apply insulating varnish as required to damaged area using paint brush.
8. Using soldering gun and tin alloy solder, solder any loose or open circuits on coil (39).

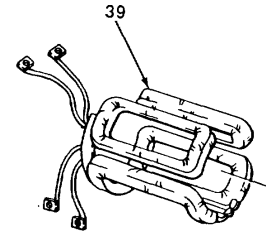
**d. ASSEMBLY**

1. If removed, install straight pin (48) in main housing (2).

NOTE

- If old sleeve bushing was removed and is being reinstalled in drive housing, perform steps 2 and 3, then proceed to step 6.
- If new sleeve bushing is being installed, skip step 2.

2. If old sleeve bushing (49) is being reinstalled, line up oil holes in sleeve bushing and drive housing (1).
3. Using arbor press and outside diameter remover and installer, press sleeve bushing (49) in drive housing (1).
4. Using electric drill and twist drill set, drill hole in new sleeve bushing (49) through oil wick hole using same size twist drill as oil wick hole.
5. After drilling new sleeve bushing (49), ream hole to 0.499-0.501 in. (12.675-12.725 mm) and remove burrs using 1/8-1/2 in. hand reamer set.
6. Apply light coat of engine oil to sleeve bushing (49).
7. Soak wick (50) in engine oil. Position wick in drive housing (1) and install pipe plug (51).

7-2. ENGINE STARTER REPAIR (Con't).

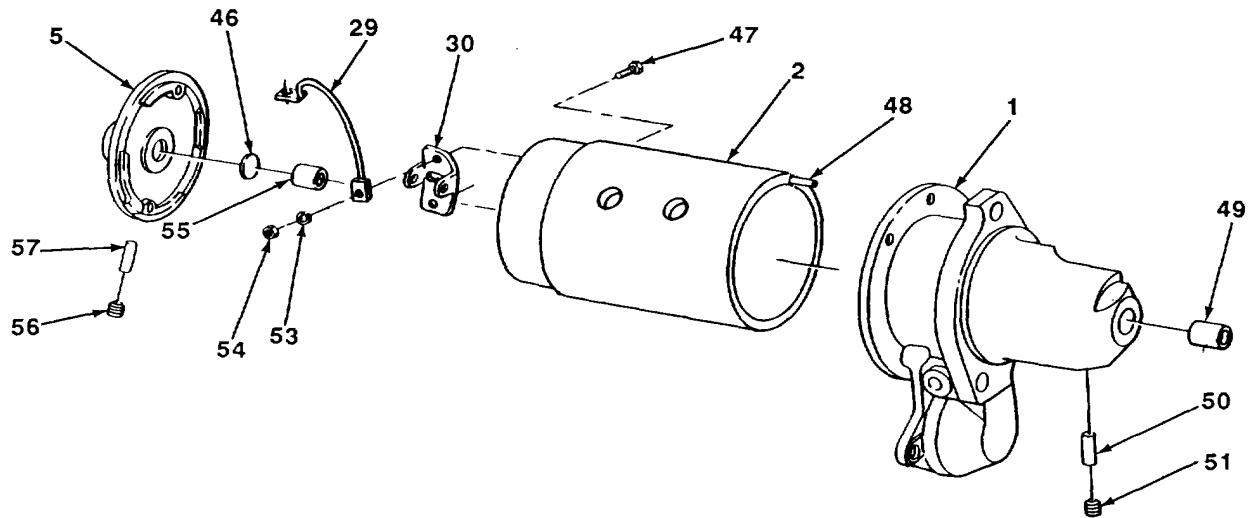
**NOTE**

- If old sleeve bushing was removed and is being reinstalled in electrical end bell, perform steps 8 and 9, then proceed to step 12.
- If new sleeve bushing is being installed, skip step 8.

8. If old sleeve bushing (55) is being reinstalled, line up oil holes in sleeve bushing and electrical end bell (5).
9. Using arbor press and X in. outside diameter remover and installer, press sleeve bushing (55) in electrical end bell (5).
10. Using electric drill and twist drill set, drill hole in sleeve bushing (55) through oil wick hole using same size twist drill as oil wick hole.
11. After drilling new sleeve bushing (55), ream hole to 0.5625-0.5635 in. (14.2875-14.3129 mm) and remove burrs using hand reamer set.
12. Apply light coat of engine oil to sleeve bushing (55).
13. Soak wick end (46) in engine oil. Install wick end in electrical end bell (5).

NOTE

Some loader backhoes do not have second wick and pipe plug.

14. Soak wick (57) in engine oil. Position wick in electrical end bell (5) and install pipe plug (56).

NOTE

If supports and leads were not removed, skip steps 15 and 16.

15. Position two supports (30) and leads (29) in place inside main housing (2).
16. Install four screws (47), new lockwashers (53), and nuts (54) in main housing (2), two supports (30), and leads (29).

7-2. ENGINE STARTER REPAIR (Con't).**CAUTION**

Be careful when handling coil and pole pieces. Scraping insulating varnish from coil could cause grounding to main frame or pole pieces, or shorted windings.

NOTE

If coil, pole pieces, and machine screws were not removed, skip step 17.

17. Position four pole pieces (40) in place on coil (39). Install coil and pole pieces in main housing (2) and secure with eight machine screws (41).
18. Install grommet (42) on end of angle bracket (6). Press grommet and angle bracket in main housing (2).
19. Install two wire terminals (45). new self-locking bolt (44), and new lockwasher (43) on angle bracket (6).

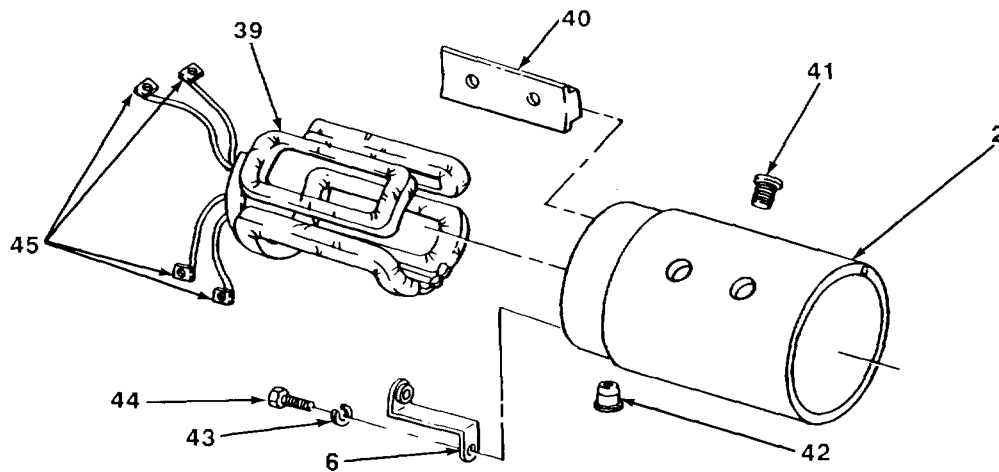

TA701352

7-2. ENGINE STARTER REPAIR (Con't).

NOTE

In steps 20 and 21, long side of brushes should be facing away from armature windings or they may contact riser bars.

- 20. Position two brushes (32) and leads (29) on two brush holders (35) and secure with two drive screws (33) and new lockwashers (34).
- 21. Position two brushes (38) and leads (29) on two brush holders (37) and secure with two drive screws (27) and new lockwashers (28).
- 22. Position four brush holders (35 and 37) with assembled parts and two springs (31) in place on two supports (30) in main housing (2).
- 23. Aline holes in four brush holders (35 and 37) and two supports (30) and install two pins (36).

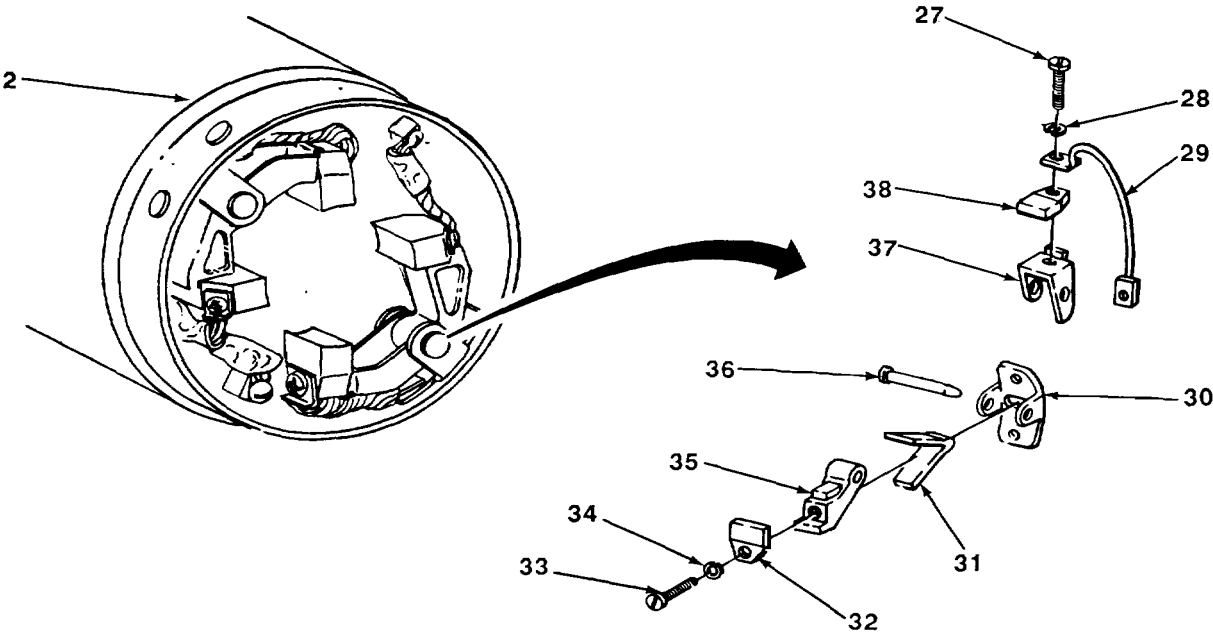

TA701353

7-2. ENGINE STARTER REPAIR (Con't).

24. Position ball bearing (21) and flatwasher (22) on shaft end of armature (9).
25. Using arbor press, press drive (10) on armature (9).
26. Install ring spacer (23), new retaining ring (24), and drive end thrust collar (25) on armature (9). Force drive end thrust collar over retaining ring.
27. Install ring spacer (20) on electrical end bell side of armature (9).
28. Position solenoid plunger (15) in vise. Aline holes in shifter fork (11) with hole in solenoid plunger and install new spring pin (26). Remove solenoid plunger and shifter fork from vise.
29. Install shifter fork (11) and solenoid plunger (15) in place on armature (9) and drive (10).

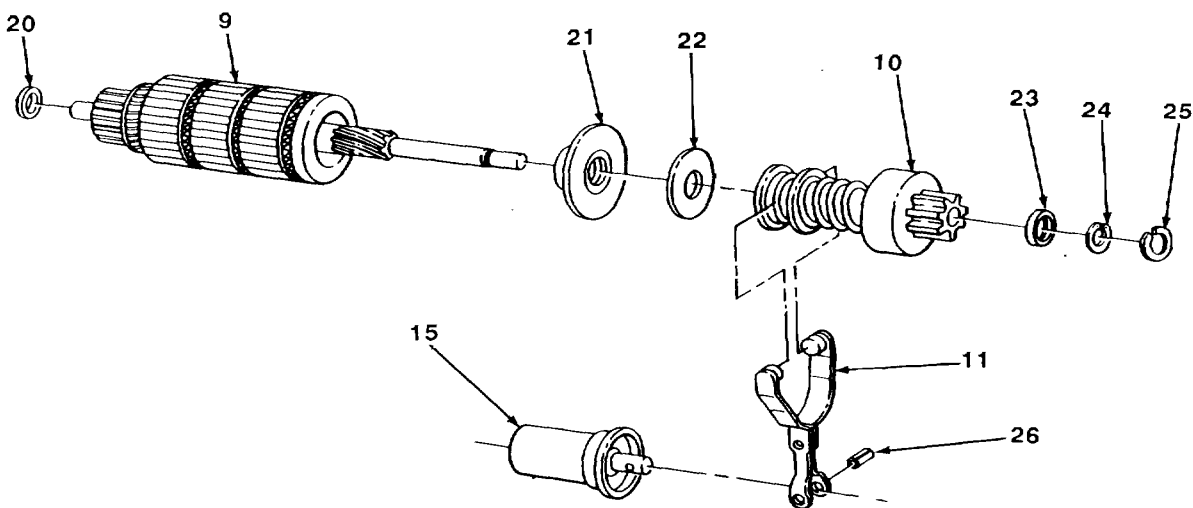

30. Install armature (9) with assembled parts in drive housing (1).
31. Install capscrew (14), new lockwasher (12), and nut (13) in drive housing (1) and shifter fork (11). Do not overtighten capscrew and nut; shifter fork and drive (10) must move freely in both directions.

WARNING

Spring on electromagnetic relay is under pressure. Hold electromagnetic relay firmly to prevent sudden release. Parts can fly out and injure personnel.

32. Position and hold new gasket (17), spring (16), and electromagnetic relay (7) on drive housing (1).
33. Install two machine screws (19) and new lockwashers (18).

TA701354

7-2. ENGINE STARTER REPAIR (Con't).

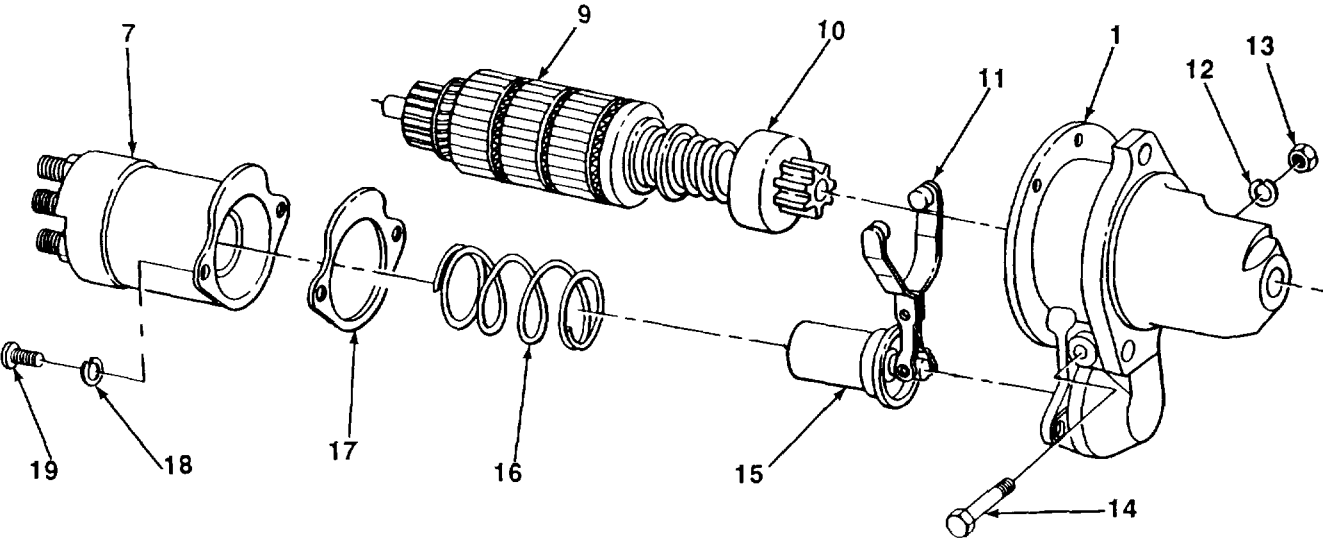

CAUTION

Be careful not to damage brushes during assembly of armature and main housing. Hold brushes clear of armature commutator until armature is in position.

- 34. Aline match-marks. Hold brushes (32 and 38) clear of commutator (58) and position electromagnetic relay (7), drive housing (1), and armature (9) with assembled parts in place in main housing (2). Release brushes.
- 35. With brushes (38) against commutator (58), loosen two drive screws (27) and allow brushes to seat on commutator, then tighten screws.

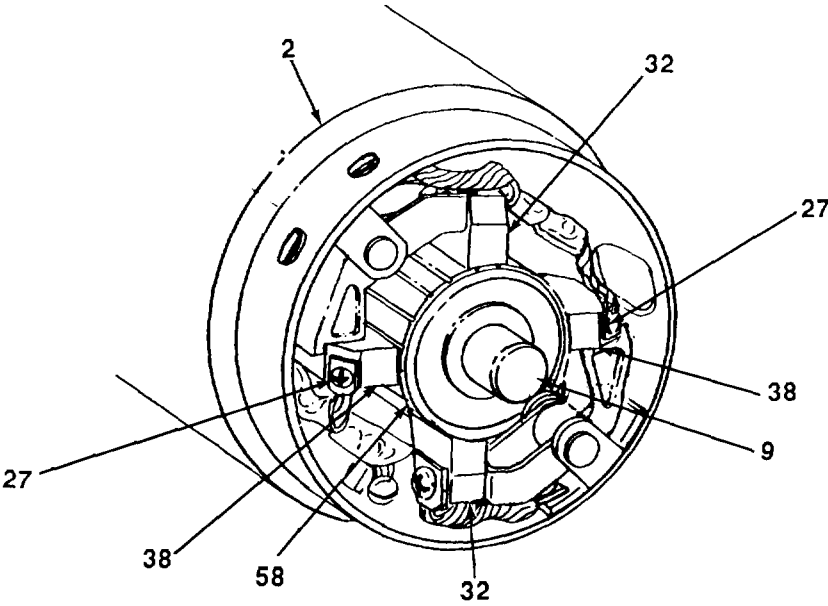

7-2. ENGINE STARTER REPAIR (Con't).

36. Repeat step 35 for brushes (32) and drive screws (33).

NOTE

Steps 37 through 40 apply only when installing new brushes.

37. Lift new brushes (32 and 38) off commutator (58) and hold. Using masking tape and fine abrasive paper with rough side facing out, cover commutator.
38. Release brushes (32 and 38) and slowly rotate armature (9) in main housing (2) until brushes seat on commutator (58).
39. Lift brushes (32 and 38) and remove fine abrasive paper and masking tape from commutator (58).

CAUTION

Ensure that all dust and abrasive particles are removed after seating new brushes. If not, commutator and brushes can be damaged or wear rapidly.

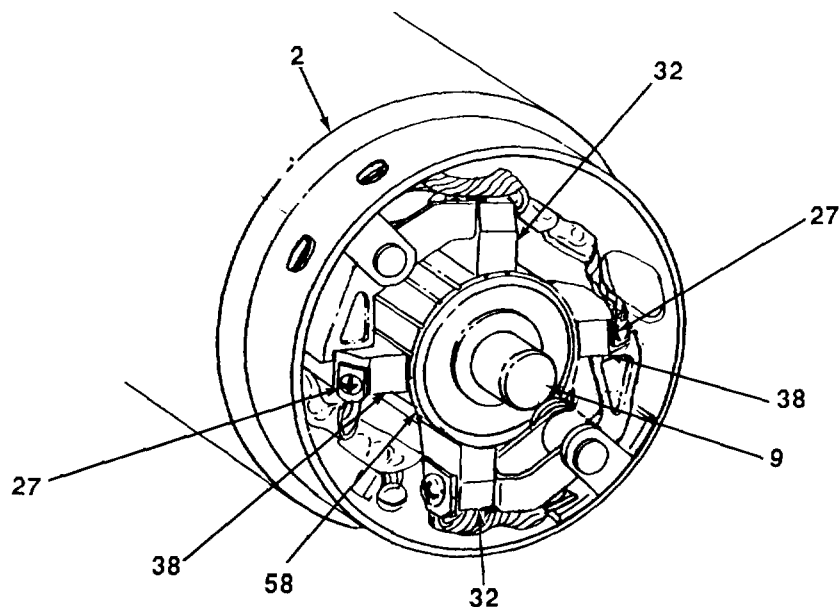

TA701356

7-2. ENGINE STARTER REPAIR (Con't).

- 41. Aline match-marks between electrical end bell (5) and main housing (2). Install electrical end bell with assembled parts on main housing and armature (9).
- 42. Install two capscrews (8) in electrical end bell (5) and main housing (2).

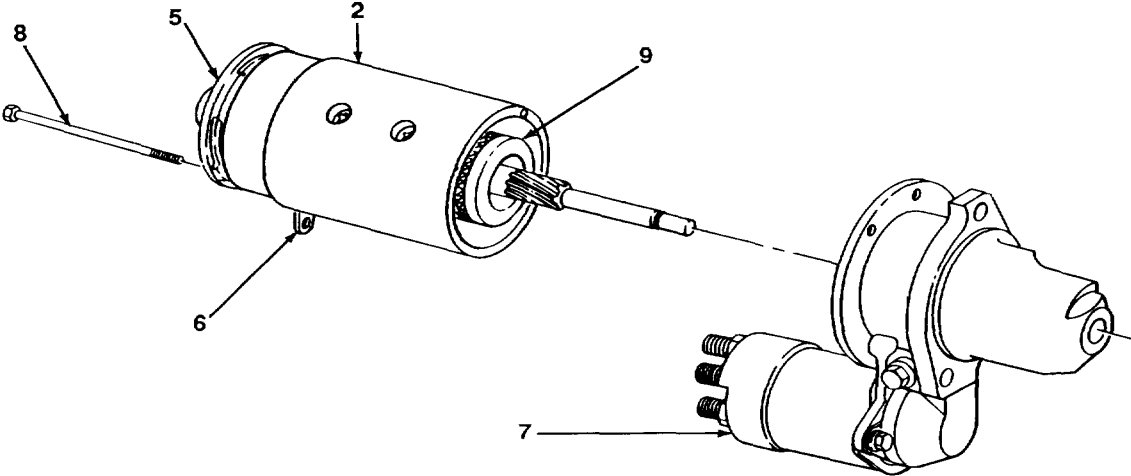

- 43. Aline hole in angle bracket (6) with hole in electromagnetic relay (7). Install machine screw (4) and new lockwasher (3) in angle bracket and electromagnetic relay.

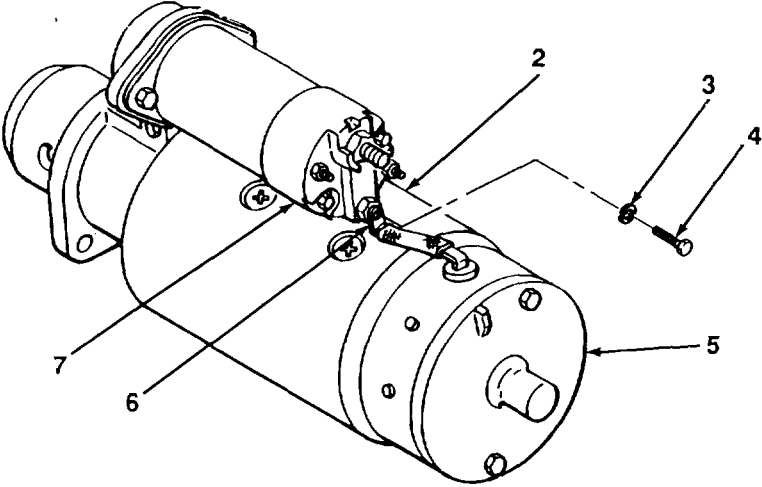

7-2. ENGINE STARTER REPAIR (Con't).

e. TEST

CAUTION

Do not turn starter for more than 20 seconds starter to cool at least two minutes before

1. Rotate armature (9) by hand. If shaft does not turn freely, do not proceed with test.
2. Disconnect all leads from the electromagnetic relay (7) and make test connections as shown.
3. Using automotive generator and starter test stand, perform starter no-load test. Current draw should be 105-200 amp at 10.6 v, with no-load speed of 6500-14,000 rpm.
4. High reading indicates a shorted or grounded hold-in winding. Low reading indicates excessive resistance.
5. Check hold-in winding at 26.5-30.5 amp with multimeter and carbon pile connected to motor terminal.

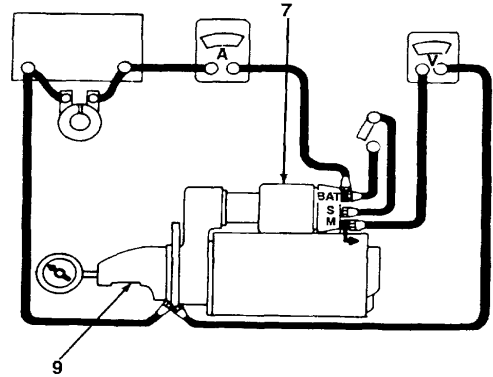
**FOLLOW-ON TASKS:**

- Install starter (see TM 5-2420-222-20).

TA701358

**CHAPTER 8
TRANSMISSION MAINTENANCE**

Paragraph Number	Paragraph Title	Page Number
8-1	Transmission Oil Pressure Test.....	8-2
8-2	Transmission Maintenance.....	8-5
8-3	Transmission Rear Cover Replacement.....	8-18
8-4	Transmission Countershaft and Bearing Support Maintenance.....	8-20
8-5	Transmission Drive Shaft Maintenance.....	8-25
8-6	Differential Drive Shaft Assembly Maintenance.....	8-29
8-7	Differential Assembly Maintenance.....	8-34
8-8	Differential Lock Pedal and Linkage Maintenance.....	8-42
8-9	Differential Lock Mechanism Maintenance.....	8-44
8-10	Gear Shifters and Shifter Shafts Maintenance.....	8-47
8-11	Reverser Speed Top Cover Replacement.....	8-54
8-12	Transmission Top Cover Maintenance (Serial Numbers 235786-235999).....	8-56
8-13	Transmission Top Cover Maintenance (Serial Numbers 319995-342573).....	8-60
8-14	Reverser Shifter Levers Replacement.....	8-62
8-15	Reverser Control Lever Linkage Replacement (Serial Numbers 235786-235999).....	8-64
8-16	Reverser Housing Maintenance.....	8-65
8-17	Reverser Brake Housing Repair.....	8-72
8-18	Reverser Clutch Drum and Disk Repair.....	8-80
8-19	Transmission Oil Pump Maintenance.....	8-85
8-20	Reverser Clutch Control Valve Assembly Maintenance.....	8-88
8-21	Reverser Oil Lines Replacement.....	8-101
8-22	Transmission Relief Valve Maintenance.....	8-104
8-23	Transmission Oil Lines Replacement.....	8-106

8-1. TRANSMISSION OIL PRESSURE TEST.

This Task Covers: Test

Initial Setup:

Equipment Conditions:

- Transmission filled (see LO 5-2420-222-12).
- Hood removed (see TM 5-2420-222-20).

Tools/Test Equipment:

- General mechanic's tool kit
- Field automotive shop set
- Hydraulic system tester

Materials/Parts:

- Rags (Item 28, Appendix B)

References:

- TM 5-2420-222-10
- TM 5-2420-222-20

Personnel Required: Two

TEST

1. Apply parking brake (see TM 5-2420-222-10).
2. Place wood blocks in front of, and behind, front and rear tires.

NOTE**Use a drain pan to catch fluid when disconnecting hoses. Clean up all spills.**

3. Loosen clamp (4) and disconnect hose (3) from oil cooler (1).
4. Loosen clamp (5) and disconnect hose (2) from oil cooler (1).
5. Install hydraulic system tester to hose (3) and hose (2).
6. Start engine assembly and increase speed to 1500 rpm (see TM 5-2420-222-10).
7. Check hydraulic system tester reading. Reading should be 7 gpm (27 lpm) at 50 psi (345 kPa).
8. While assistant rapidly shifts speed gear assembly control lever from reverse to forward (see TM 5-2420-222-10), check hydraulic system tester reading.
9. Reading should be 20-50 psi (138-345 kPa) within 0.1 second after start of shift. Reading should increase to 100 psi (690 kPa) between 0.8-1.2 seconds after start of shift. Reading should increase to 145-165 psi (1000-1138 kPa) within 1.2 seconds after start of shift.
10. While assistant rapidly shifts speed gear assembly control lever from forward to reverse (see TM 5-2420-222-10), check hydraulic system tester reading.
11. Reading should be 10-30 psi (69-207 kPa) within 0.1 second after start of shift. Reading should increase to 100 psi (690 kPa) between 0.8-1.2 seconds after start of shift. Reading should increase to 145-165 psi (1000-1138 kPa) within 1.2 seconds after start of shift.
12. Shut down engine assembly (see TM 5-2420-222-10).
13. Remove hydraulic system tester from hose (2) and hose (3).
14. Position hose (2) on oil cooler (1) and tighten clamp (5).
15. Position hose (3) on oil cooler (1) and tighten clamp (4).

8-1. TRANSMISSION OIL PRESSURE TEST (Con't).

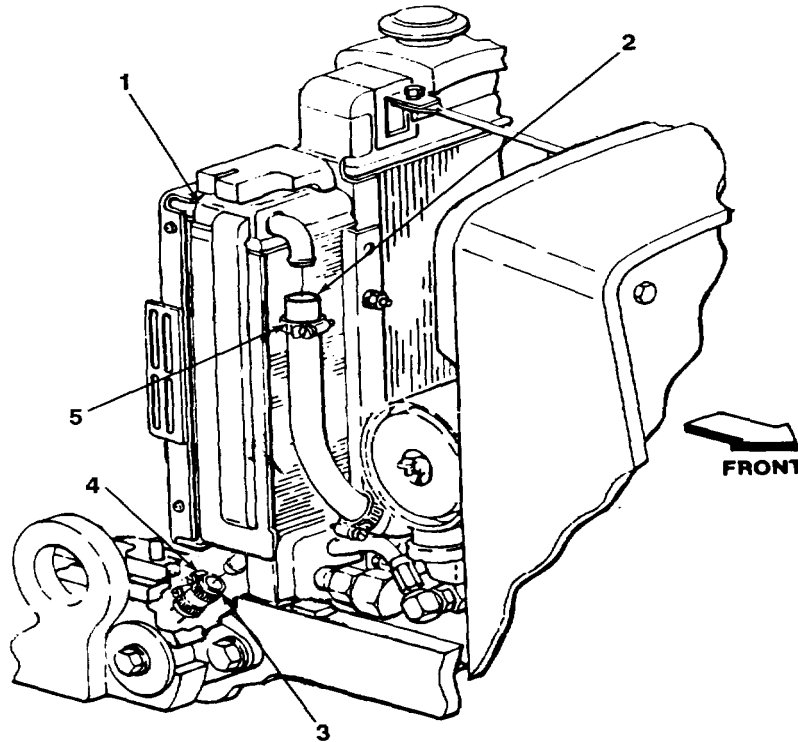

16. Install hood (see TM 5-2420-222-20).
17. Release parking brake (see TM 5-2420-222-10). Remove wood blocks from front and rear tires.
18. Start engine assembly and increase speed to fast idle (see TM 5-2420-222-10).
19. Depress clutch pedal to disengage clutch (see TM 5-2420-222-10). Position speed gear assembly control lever in forward position (see TM 5-2420-222-10).
20. Release clutch pedal to engage clutch until axles start to move, then depress clutch pedal to disengage clutch (see TM 5-2420-222-10).
21. Hold brakes, then position transmission range shift lever in high (see TM 5-2420-222-10).
22. Position gearshift lever in eighth gear (see TM 5-2420-222-10).
23. Release clutch pedal to engage clutch (see TM 5-2420-222-10). Engine should stall within five seconds after engaging clutch.
24. Start engine assembly and increase speed to fast idle (see TM 5-2420-222-10).

TA701359

8-1. TRANSMISSION OIL PRESSURE TEST (Con't).

25. Depress clutch pedal to disengage clutch (see TM 5-2420-222-10). Position speed gear assembly control lever in reverse (see TM 5-2420-222-10).
26. Release clutch pedal to engage clutch until axles start to move, then depress clutch pedal to disengage clutch (see TM 5-2420-222-10).
27. Hold brakes, then position transmission range shift lever in low (see TM 5-2420-222-10).
28. Position gearshift lever in fourth gear (see TM 5-2420-222-10).
29. Release clutch pedal to engage clutch (see TM 5-2420-222-10). Engine should stall within five seconds after engaging clutch.
30. If running, shut down engine assembly (see TM 5-2420-222-10).

FOLLOW-ON TASKS:

- Fill transmission (see LO 5-2420-222-12).

8-2. TRANSMISSION MAINTENANCE.

This Task Covers:

- | | |
|----------------------------|-----------------|
| a. Removal | d. Repair |
| b. Disassembly | e. Assembly |
| c. Cleaning and Inspection | f. Installation |
-

Initial Setup:

Equipment Conditions:

- Transmission liquid level gage rod removed (see TM 5-2420-222-10).
 - Center platform removed (see TM 5-2420-222-20).
 - Battery tray removed (see TM 5-2420-222-20).
 - Right inner platform ramp removed (see TM 5-2420-222-20).
 - Left platform removed (see TM 5-2420-222-20).
 - Left outer platform ramp removed (see TM 5-2420-222-20).
 - Parking brake lever and linkage removed (see TM 5-2420-222-20).
 - Steering valve-to-transmission return oil line removed (see TM 5-2420-222-20).
 - Left and right service brake lines and fittings removed (see TM 5-2420-222-20).
 - Pressure control valve removed (see TM 5-2420-222-20)
 - Loader control valve mounting bracket removed (see TM 5-2420-222-20).
 - Jaw control valve bracket removed (see TM 5-2420-222-20).
 - Differential lock pedal and linkage removed (see paragraph 8-8).
 - Hydraulic brake cylinder housing removed (see paragraph 10-4).
 - Reverser speed top cover removed (see paragraph 8-11).
 - Roll-over protective structure or canopy rear mounts removed (see paragraph 13-4).
-

Materials/Parts:

- Grease (Item 22, Appendix B)
- Rags (Item 28, Appendix B)
- Dry cleaning solvent (Item 31, Appendix B)
- Two gaskets
- Two lifting eyes
- Two preformed packings
- Ten lockwashers

Tools/Test Equipment:

- General mechanic's tool kit
- Field automotive shop set
- Steam cleaner

Personnel Required: Three**General Safety Instructions:**

- Dry cleaning solvent is flammable and must not be used near open flame. Use Only in a well-ventilated area.
 - Compressed air used for Cleaning purposes should never exceed 30 psi (207 kPa)
 - Avoid contact with live steam.
-

8-2. TRANSMISSION MAINTENANCE (Con't).

a. REMOVAL

1. Support rear of engine assembly (1) with wood blocks.
2. Install two lifting eyes (3) in upper holes (4) of reverser housing (2).

WARNING

Use extreme caution when handling heavy parts. Lifting device is required when parts weigh over 50 lb (23 kg) for a single person lift, over 100 lb (45 kg) for a two person lift, and over 150 lb (68 kg) for a three or more person lift. Keep clear of heavy parts supported only by lifting device. Failure to follow this warning may cause serious injury or death to personnel.

3. Install lifting device to two lifting eyes (3), around left and right rear axle housings (5), and attach to lifting equipment.
4. Using lifting device, support transmission (6) and reverser housing (2).
5. Loosen clamp (10) and remove hose (11) from adapter (9).

NOTE

Note screw lengths and placement during removal to ensure proper installation.

6. Remove six screws (7) and eight lockwashers (8) from reverser housing (2) and engine assembly (1). Discard lockwashers.
7. Remove two screws (13) and lockwashers (12) from engine assembly (1) and reverser housing (2). Discard lockwashers.

CAUTION

When separating transmission with attached parts from loader backhoe, move transmission away very slowly. Ensure that no hydraulic lines or linkages are in the way. Failure to do so may damage hydraulic system parts.

8. Using lifting device and the aid of two assistants, raise transmission (6) and reverser housing (2) with attached parts clear of engine assembly (1) and loader backhoe.
9. Lower lifting device and support transmission (6), reverser housing (2), and rear axle housings (5) on wood blocks. Remove lifting device and two lifting eyes (3) from transmission and reverser housing.

8-2. TRANSMISSION MAINTENANCE (Con't).

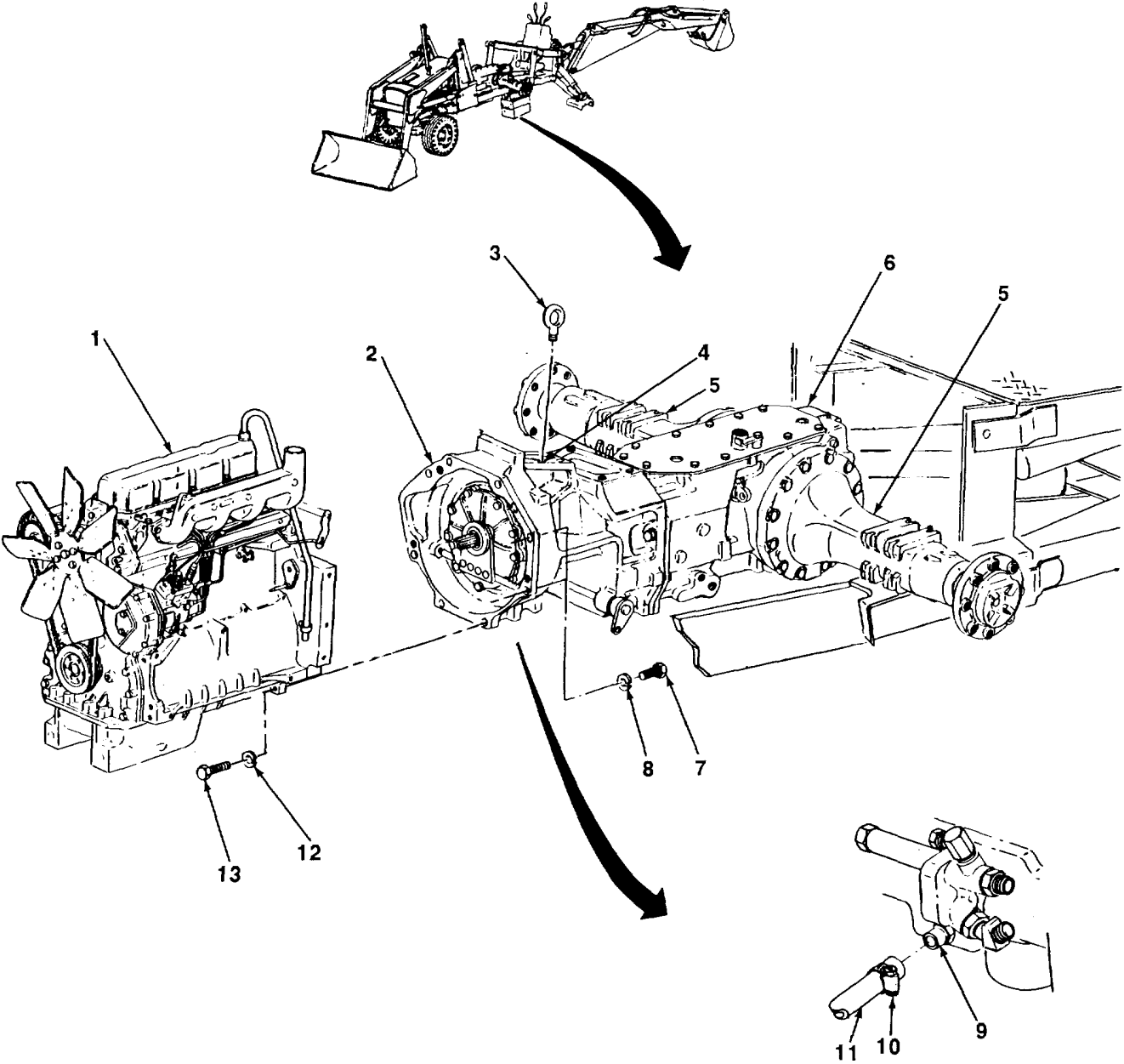

TA701360

8-2. TRANSMISSION MAINTENANCE (Con't).**NOTE**

Transmission has two rear axle housings. Removal of rear axle housings is the same. Left side is shown. Repeat steps 10 and 11 as required for right side.

10. Using lifting device, support rear axle housing (5). Remove 12 screws (14) from rear axle housing and transmission (6).
11. Using lifting device and the aid of an assistant, lift rear axle housing (5) and gasket (15) off transmission (6) and set on wood blocks. Discard gasket.
12. Remove reverser housing (see paragraph 8-16).

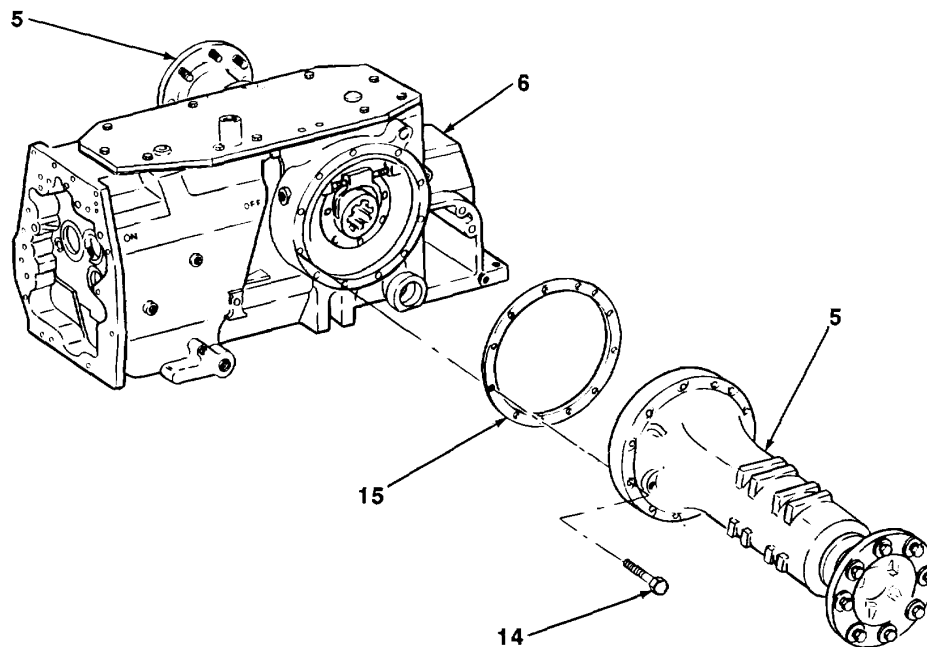
**b. DISASSEMBLY**

1. Remove transmission rear cover (see paragraph 8-3).
2. Remove transmission countershaft and bearing support (see paragraph 8-4)
3. Remove transmission drive shaft (see paragraph 8-5).
4. Remove differential drive shaft assembly (see paragraph 8-6).
5. Remove differential lock mechanism (see paragraph 8-9).
6. Remove transmission relief valve (see paragraph 8-22).

TA701361

8-2. TRANSMISSION MAINTENANCE (Con't).

- 7. Remove transmission oil lines (see paragraph 8-23).
- 8. Remove capscrew (29), washer (30), and spring (31) from transmission (6).
- 9. Using magnetic retrieving tool, remove ball bearing (32) from transmission (6).
- 10. Remove straight adapter (33) and three expansion plugs (16) from transmission (6).
- 11. Remove nut (28) from setscrew (27) and transmission (6).

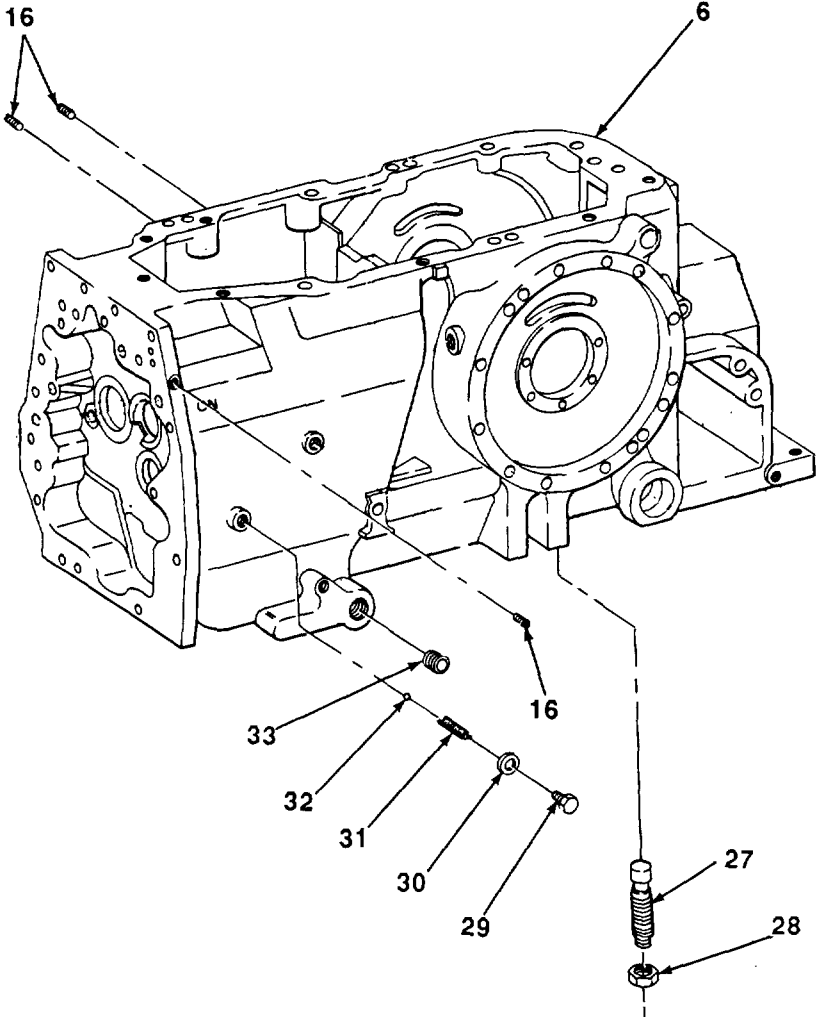

8-2. TRANSMISSION MAINTENANCE (Con't).

NOTE

Note number of exposed threads on setscrew before removal.

12. Using multiple tongue and groove slip-joint pliers, remove setscrew (27) and preformed packing (26) from transmission (6). Discard preformed packing.

CAUTION

Do not remove plugs or straight pins in steps 13 through 16 unless damaged. Removal may damage parts.

13. Remove three plugs (19) from transmission (6).
14. Remove transmission plug (25) from transmission (6).
15. Remove one straight pin (20) and four straight pins (21) from transmission (6).
16. Remove two straight pins (38) and sleeve bushing (36) from transmission (6).
17. Remove pipe plug (22) from transmission (6).
18. Remove protective cap plug (18) and metallic tube (17) from transmission (6).
19. Remove drain plug (34) and spring tension washer (35) from transmission (6).
20. Remove drain plug (24) and preformed packing (23). Discard preformed packing.

CAUTION

Do not remove sleeve bushing unless damaged. Removal may damage parts.

21. Using ball-peen hammer and drift, remove c' eve bushing (37) from transmission (6).

c. CLEANING AND INSPECTION

WARNING

Avoid contact with live steam. Live steam can burn skin, cause blindness, and cause other serious injury. Be sure to wear protective apron, gloves, and safety goggles when using live steam.

1. Using steam cleaner, clean outside of transmission. Clean all holes and recesses and remove all foreign matter from inside transmission.

WARNING

Compressed air used for cleaning or drying purposes, or for clearing restrictions, should never exceed 30 psi (207 kPa). Wear protective clothing (goggles/shield, gloves, etc.) and use caution to avoid injury to personnel.

2. Flush transmission with clean water. Dry thoroughly with compressed air.

8-2. TRANSMISSION MAINTENANCE (Con't).

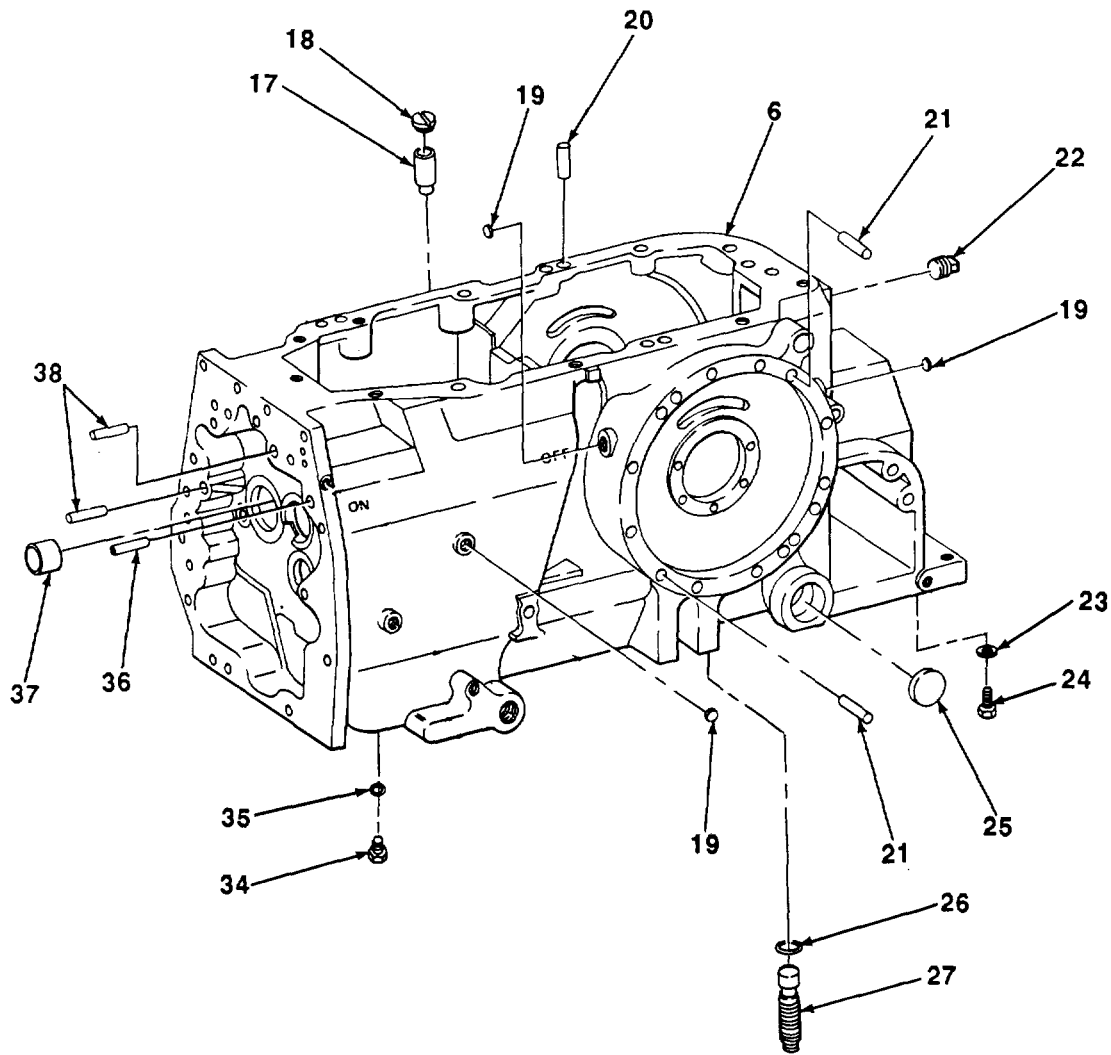
**WARNING**

Dry cleaning solvent, P-D-680, is toxic and flammable. Always wear protective goggles and gloves, and use only in a well-ventilated area. Avoid contact with skin, eyes, and clothes, and **DO NOT** breathe vapors. **DO NOT** use near open flame or excessive heat. The solvent's flash point is 100°F-138°F (38°C-59°C). If you become dizzy while using cleaning solvent, immediately get fresh air and medical help. If solvent contacts eyes, immediately wash your eyes and get medical aid.

3. Using dry cleaning solvent and clean rags, wipe all other metal parts clean. Dry with clean, dry rags.
4. Inspect transmission for cracks, breaks, and abnormal bends and wear. Check braking surfaces for excessive scoring.

8-2. TRANSMISSION MAINTENANCE (Con't).

5. Inspect all metal parts for cracks, breaks, abnormal bends, and excessive wear. Inspect threaded parts for damaged threads.

d. REPAIR NOTE**NOTE**

Transmission braking surfaces can be repaired with transmission installed and rear axle housings removed as outlined in service brake disk and pressure plate repair (see paragraph 10-3).

Restore damaged threads using screw threading set.

e. ASSEMBLY**NOTE**

Perform step 1 only if sleeve bushing was removed.

1. Using ball-peen hammer and drift, install sleeve bushing (37) in transmission (6).
2. Install drain plug (24) and new preformed packing (23) in transmission (6).
3. Install drain plug (34) and spring tension washer (35) in transmission (6).
4. Install metallic tube (17) and protective cap plug (18) in transmission (6).
5. Install pipe plug (22) in transmission (6).

NOTE

Perform steps 6 through 9 only if plugs or straight pins were removed.

6. Install two straight pins (38) and sleeve bushing (36) in transmission (6).
7. Install one straight pin (20) and four straight pins (21) in transmission (6).
8. Install transmission plug (25) in transmission (6).
9. Install three plugs (19) in transmission (6).
10. Using multiple tongue and groove slip-joint pliers, install setscrew (27) and new preformed packing (26) in transmission (6) until number of exposed threads on setscrew is the same as noted during disassembly. Install nut (28) on setscrew.
11. Install straight adapter (33) and three expansion plugs (16) in transmission (6).
12. Using magnetic retrieving tool, install ball bearing (32) in transmission (6). Install spring (31), washer (30), and capscrew (29).
13. Install transmission oil lines (see paragraph 8-23).
14. Install transmission relief valve (see paragraph 8-22).
15. Install differential lock mechanism (see paragraph 8-9).

8-2. TRANSMISSION MAINTENANCE (Con't).

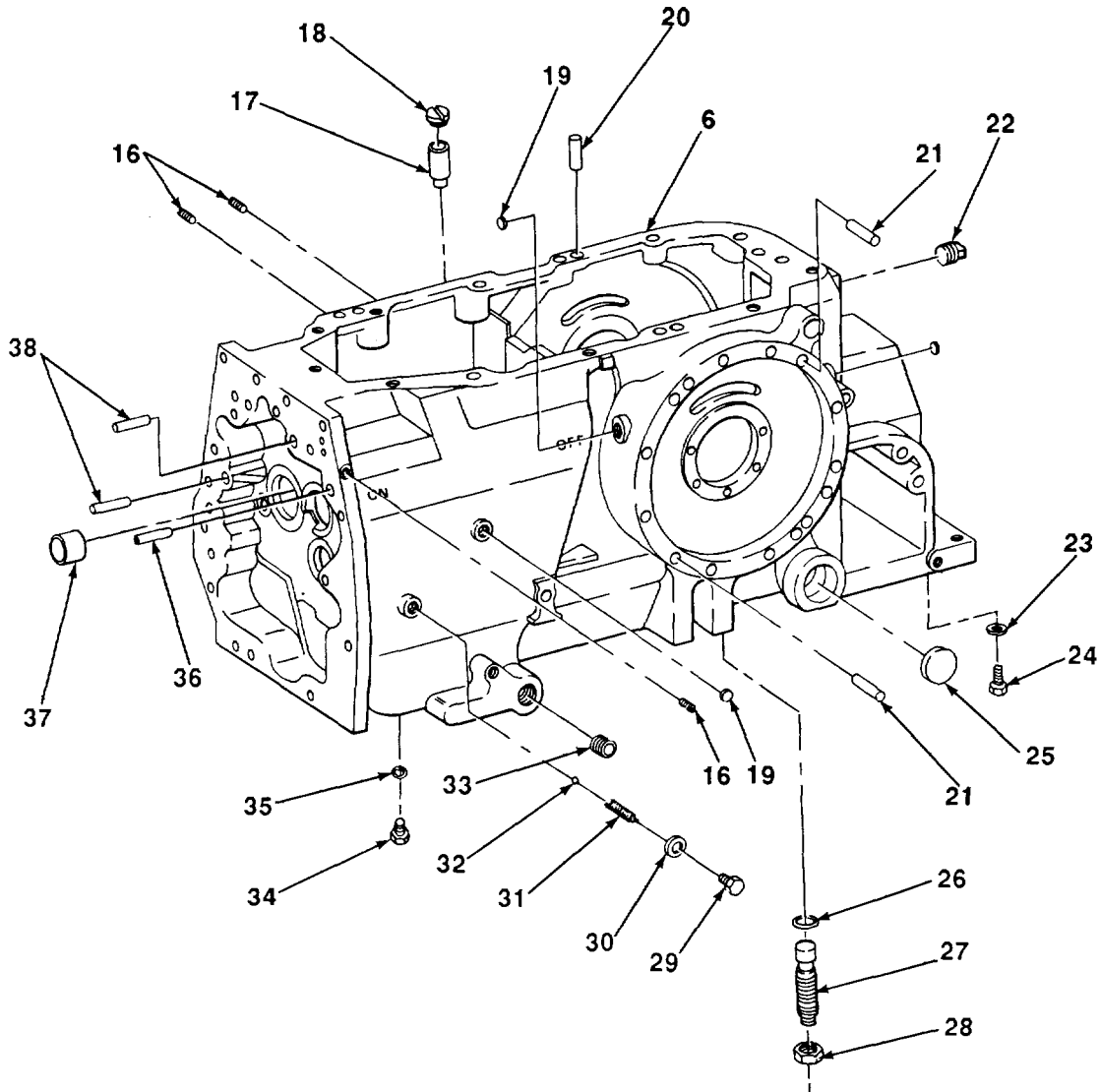

- 16. Install differential drive shaft assembly (see paragraph 8-6).
- 17. Install transmission drive shaft (see paragraph 8-5).
- 18. Install transmission countershaft and bearing support (see paragraph 8-4).
- 19. Install transmission rear cover (see paragraph 8-3).

f. INSTALLATION

- 1. Install reverser housing (see paragraph 8-16).

8-2. TRANSMISSION MAINTENANCE (Con't).**NOTE**

Transmission has two rear axle housings. Installation of rear axle housings is the same. Left side is shown. Repeat steps 2 through 7 as required for right side.

2. Remove brake disk (39) and brake pressure plate (40) from rear axle housing (5).
3. Apply coat of grease to brake pressure plate (40), then position back in rear axle housing (5).

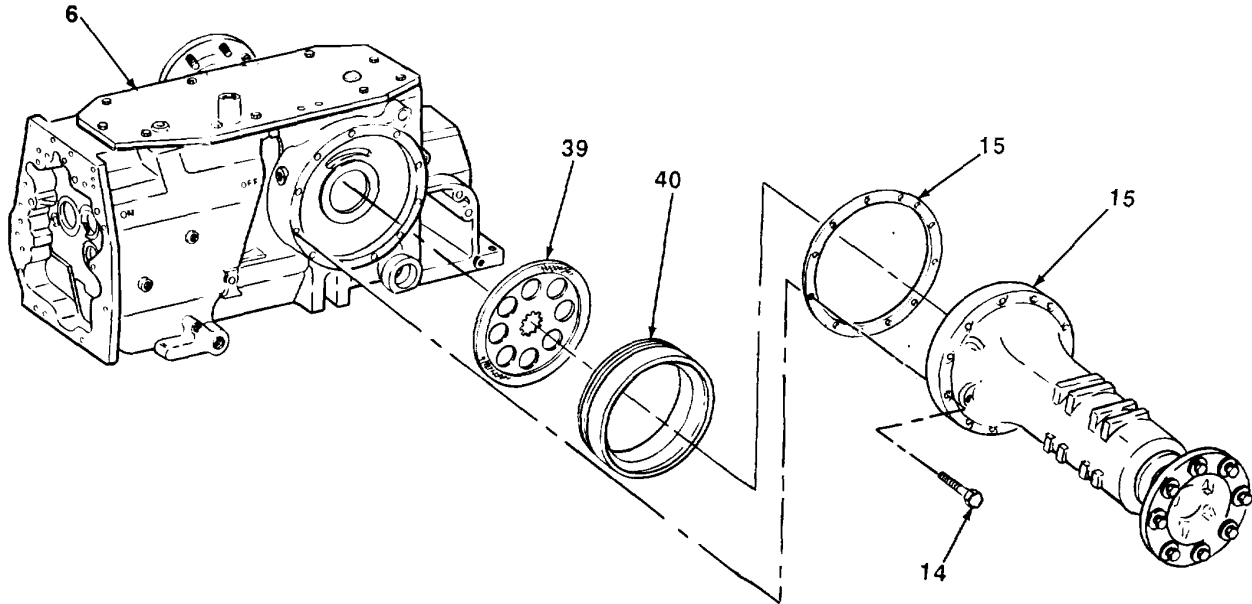
**WARNING**

Use extreme caution when handling heavy parts. Lifting device is required when parts weigh over 50 lb (23 kg) for a single person lift, over 100 lb (45 kg) for a two person lift, and over 150 lb (68 kg) for a three or more person lift. Keep clear of heavy parts supported only by lifting device. Failure to follow this warning may cause serious injury or death to personnel.

5. Using lifting device and the aid of an assistant, lift and position rear axle housing (5) and new gasket (15) in place against transmission (6) with screw holes aligned.
6. Install 12 screws (14) in transmission (6) and rear axle housing (5). Torque screws alternately to 85 lb.-ft. (115 N•m).
7. Support rear axle housing (5) with wood blocks and remove lifting device.

CAUTION

When installing transmission, ensure that all loose parts are clear or parts may be damaged.

8. Install two lifting eyes (3) in upper holes (4) of reverser housing (2).

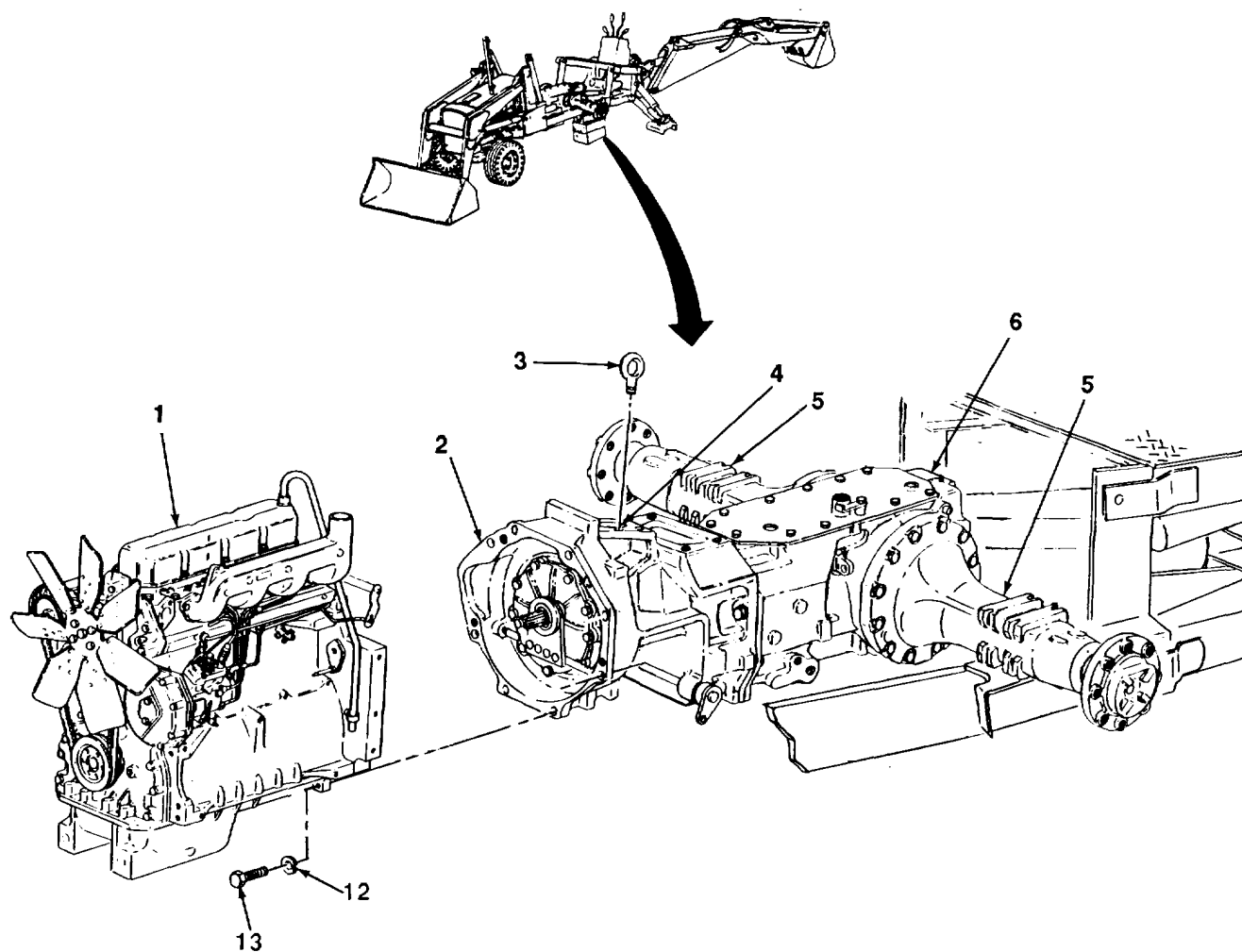
8-2. TRANSMISSION MAINTENANCE (Con't).

9. Using lifting device and the aid of two assistants, raise transmission (6), reverser housing (2), and rear axle housings (5) off wood blocks and move into position against engine assembly (1).
10. Install two screws (13) and new lockwashers (12) in engine assembly (1) and reverser housing (2).

TA701366

8-2. TRANSMISSION MAINTENANCE (Con't).

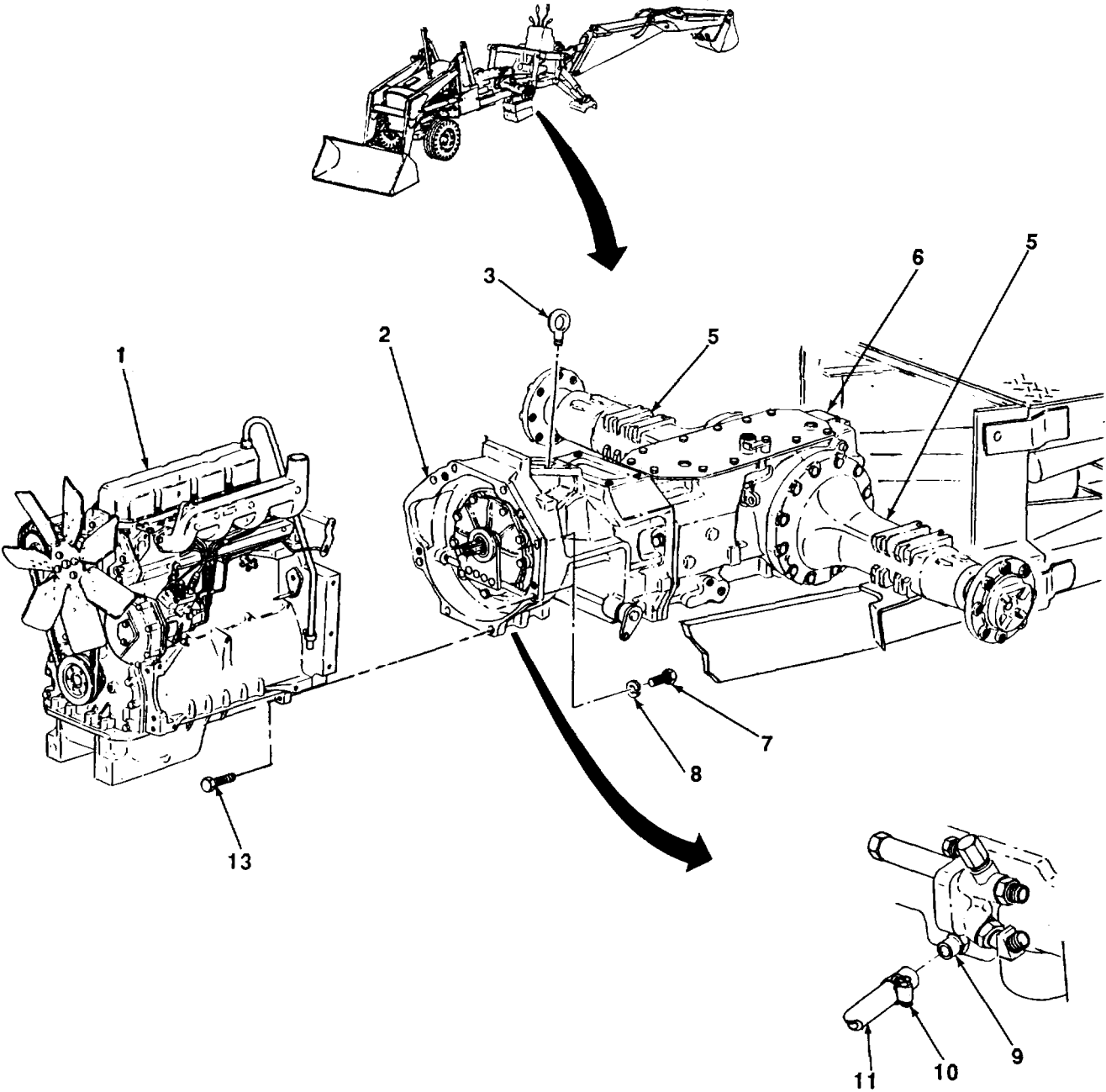

TA701367

8-2. TRANSMISSION MAINTENANCE (Con't).

11. Install six screws (7) and eight new lockwashers (8) in reverser housing (2) and engine assembly (1). Torque screws (7 and 13) to 130 lb.-ft. (176 Nom).
12. Position hose (11) on adapter (9) and tighten clamp (10).
13. Remove wood blocks from under rear of engine assembly (1).
14. Remove two lifting eyes (3) and lifting device from transmission (6), reverser housing (2), and rear axle housings (5).

FOLLOW-ON TASKS:

- Install roll-over protective structure or canopy rear mounts (see paragraph 13-4).
- Install reverser speed top cover (see paragraph 8-11).
- Install hydraulic brake cylinder housing (see paragraph 10-4).
- Install differential lock pedal and linkage (see paragraph 8-8).
- Install jaw control valve bracket (see TM 5-2420-222-20).
- Install loader control valve mounting bracket (see TM 5-2420-222-20).
- Install pressure control valve (see TM 5-2420-222-20).
- Install right and left service brake lines and fittings (see TM 5-2420-222-20).
- Install steering valve-to-transmission return oil line (see TM 5-2420-222-20).
- Install parking brake lever and linkage (see TM 5-2420-222-20).
- Install left outer platform ramp (see TM 5-2420-222-20).
- Install left platform (see TM 5-2420-222-20).
- Install right inner platform ramp (see TM 5-2420-222-20).
- Install battery tray (see TM 5-2420-222-20).
- Install center platform (see TM 5-2420-222-20).
- Install transmission liquid level gage rod (see TM 5-2420-222-10).

8-3. TRANSMISSION REAR COVER REPLACEMENT.*This Task Covers:*

- | | |
|------------|-----------------|
| a. Removal | b. Installation |
|------------|-----------------|

*Initial Setup:***Tools/Test Equipment:**

- General mechanic's tool kit

Materials/Parts:

- One gasket
- Three lockwashers (serial numbers 235786-235999)

a. REMOVAL**NOTE**

**Perform steps 1 and 2 for loader backhoes with serial numbers 235786-235999.
Perform steps 3 and 4 for loader backhoes with serial numbers 319995-342573.**

1. Remove three capscrews (1) and lockwashers (2) from rear cover (3) and transmission (5). Discard lockwashers.
2. Pry rear cover (3) and gasket (4) off transmission (5). Discard gasket.
3. Remove four nuts (10) and lockplates (9) from rear cover (8) and transmission (5).
4. Remove rear cover (8) and gasket (7) from four studs (6) and transmission (5). Discard gasket.

b. INSTALLATION**NOTE**

**Perform steps 1 and 2 for loader backhoes with serial numbers 235786-235999.
Perform steps 3 and 4 for loader backhoes with serial numbers 319995-342573.**

1. Position rear cover (3) and new gasket (4) in place on transmission (5).
2. Install three capscrews (1) and new lockwashers (2) in rear cover (3) and transmission (5).
3. Position rear cover (8) and new gasket (7) in place on four studs (6) and transmission (5).
4. Install four nuts (10) and lockplates (9) on studs (6).

8-3. TRANSMISSION REAR COVER REPLACEMENT (Con't).

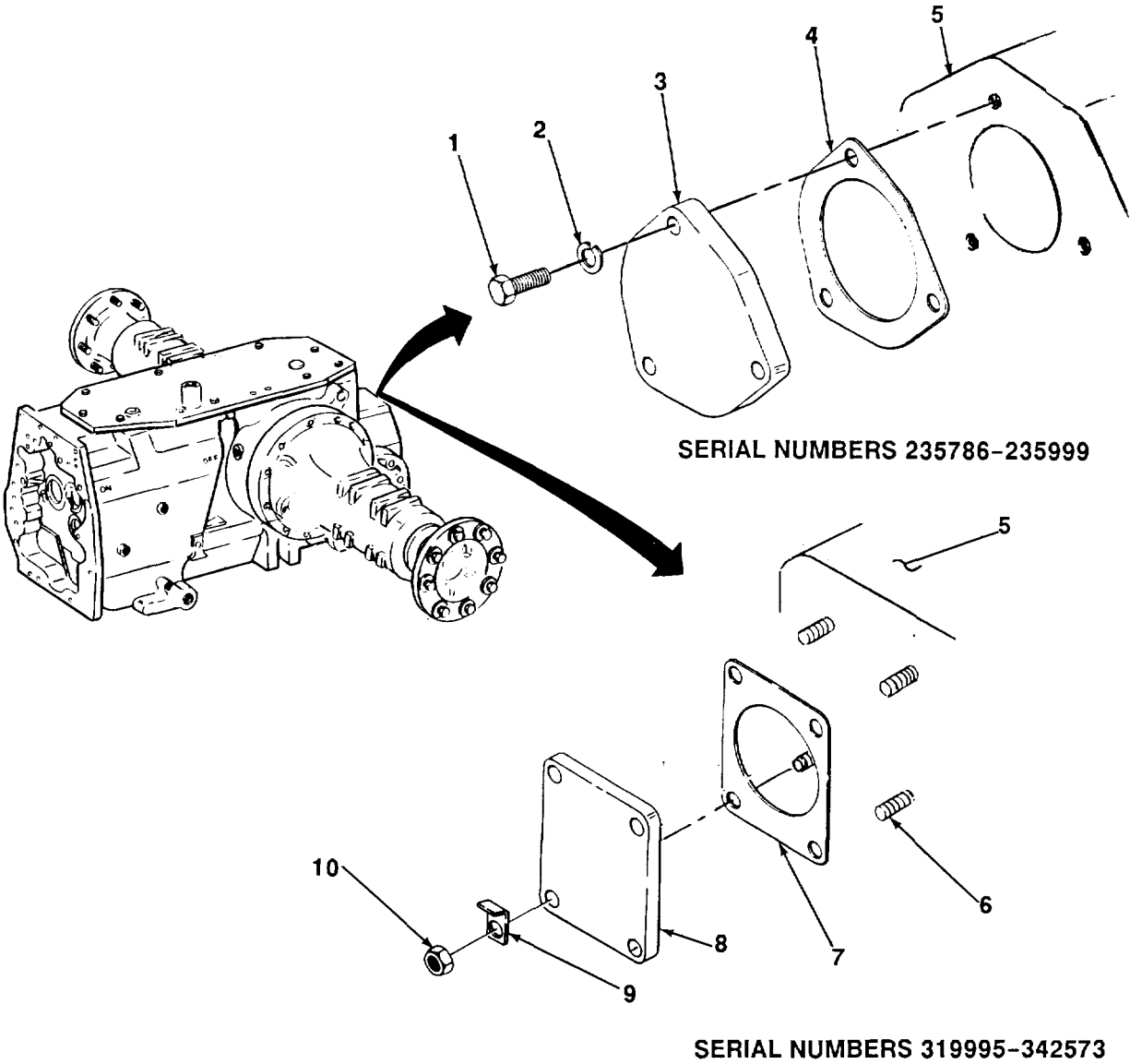

8-4. TRANSMISSION COUNTERSHAFT AND BEARING SUPPORT MAINTENANCE.*This Task Covers:*

- | | |
|----------------------------|-----------------|
| a. Removal | d. Repair |
| b. Disassembly | e. Assembly |
| c. Cleaning and Inspection | f. Installation |

*Initial Setup:***Equipment Conditions:**

- Gear shifters and shifter shafts removed (see paragraph 8-10).

Tools/Test Equipment:

- General mechanic's tool kit
- Field automotive shop set

References:

- TM 9-214

Materials/Parts:

- Rags (Item 28, Appendix B)
- Dry cleaning solvent (Item 31, Appendix B)
- Two special washers

Personnel Required: Two**General Safety Instructions:**

- Dry cleaning solvent is flammable and must not be used near open flame. Use only in a well-ventilated area.

a. REMOVAL

1. Bend locking tabs of clamp (24) away from two screws (23) and remove screws, two screws (4), two special washers (5), and clamp. Discard special washers.
2. Using retaining ring pliers, remove retaining ring (17) from groove in countershaft (8) and slide off splines.
3. Rotate thrust washer bearing (18) on countershaft (8) until splines align, then slide thrust washer bearing off splines.
4. Pry bearing support (6) away from transmission (12) and two sleeve bushings (14).

NOTE**Note position of parts during removal to ensure proper installation.**

5. With the aid of an assistant, remove countershaft (8) with assembled bearing support (6), retaining ring (17), thrust washer bearing (18), low range bevel gear (19), sleeve (11), thrust washer bearing (10), collar (9), two plugs (27), springs (26), and spacer rings (25) from needle bearing (15), transmission (12), and drive gear (13).
6. Using retaining ring pliers, remove retaining ring (16) from needle bearing (15), transmission (12), and drive gear (13).
7. Remove needle bearing (15) from transmission (12).

CAUTION**Do not remove sleeve bushings unless damaged. Removal may damage parts.**

8. Using hammer and punch, drive sleeve bushings (14) out of transmission (12).

8-4. TRANSMISSION COUNTERSHAFT AND BEARING SUPPORT MAINTENANCE (Con't).

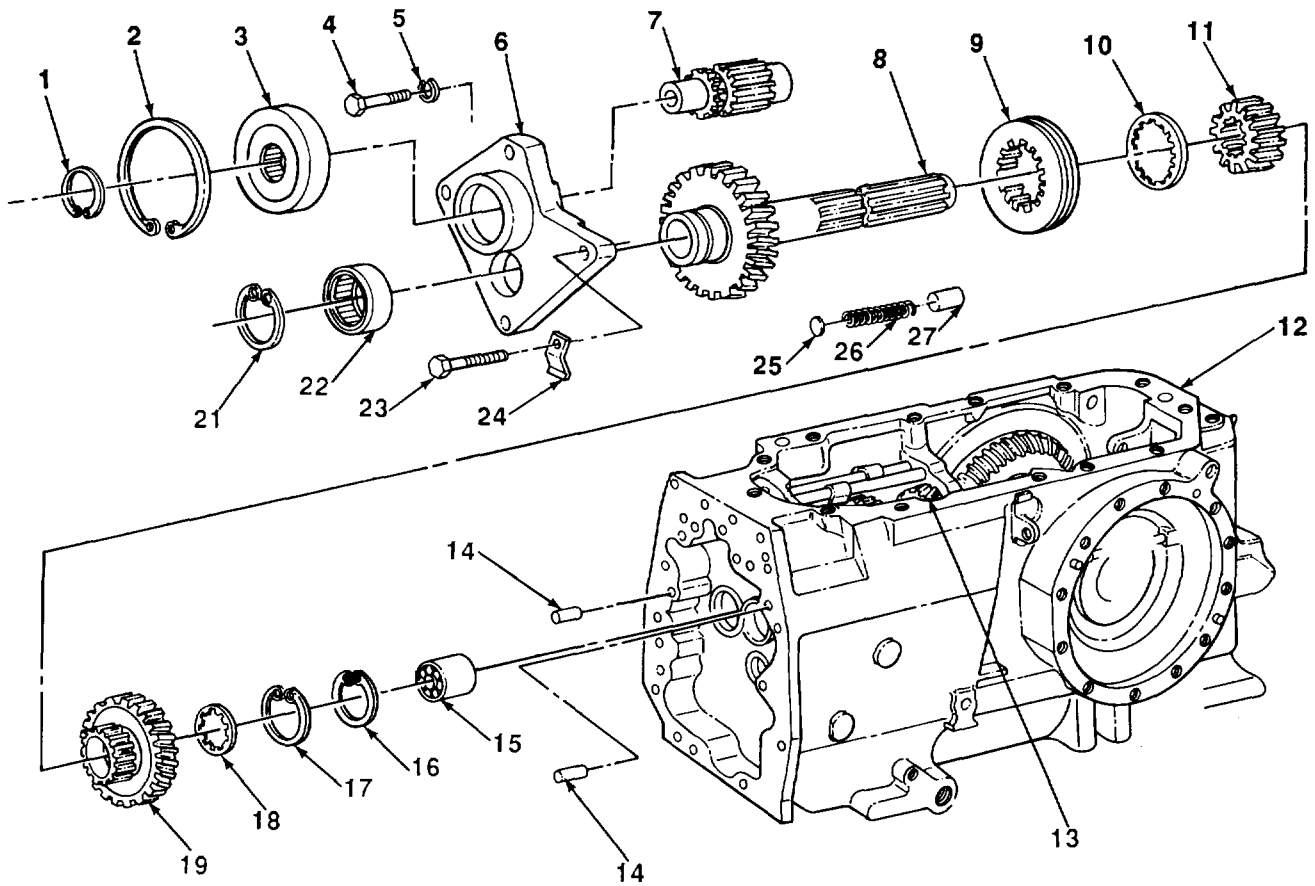
**b. DISASSEMBLY****NOTE**

Perform steps 1 through 8 for loader backhoes with serial numbers 319995-342573 only.

1. Using retaining ring pliers, remove retaining ring (2) from ball bearing (3) and bearing support (6).
2. Using remover and installer and arbor press, remove helical gearshaft (7) and ball bearing (3) from bearing support (6).
3. Using retaining ring pliers, remove retaining ring (21) from ball bearing (22) and bearing support (6).
4. Using remover and installer and arbor press, remove countershaft (8) with assembled ball bearing (22) from bearing support (6).
5. Using retaining ring pliers, remove retaining ring (1) from ball bearing (3) and helical gearshaft (7).

TA701369

8-4. TRANSMISSION COUNTERSHAFT AND BEARING SUPPORT MAINTENANCE (Con't).

6. Using mechanical gear and bearing puller kit, remove ball bearing (3) from helical gearshaft (7).
7. Using retaining ring pliers, remove retaining ring (20) from ball bearing (22) and countershaft (8).
8. Using mechanical gear and bearing puller kit, remove ball bearing (22) from countershaft (8).

c. CLEANING AND INSPECTION**WARNING**

Dry cleaning solvent, P-D-680, is toxic and flammable. Always wear protective goggles and gloves, and use only in a well-ventilated area. Avoid contact with skin, eyes, and clothes, and DO NOT breathe vapors. DO NOT use near open flame or excessive heat. The solvent's flash point is 1000F-1380F (38°C-590C). If you become dizzy while using cleaning solvent, immediately get fresh air and medical help. If solvent contacts eyes, immediately wash your eyes and get medical aid.

1. Clean all metal parts with dry cleaning solvent. Dry thoroughly with clean, dry rags.
2. Inspect helical gearshaft, countershaft, low range bevel gear, collar, sleeve, and two thrust washer bearings for cracks, bends, breaks, and missing or damaged teeth or splines. Replace if defective.
3. Inspect ball bearings (see TM 9-214).
4. Inspect springs for cracks, breaks, and abnormal bends. Using spring tester and torque wrench, compress springs to 1.5 in. (38.1 mm) and check compression force on torque wrench. Compression force must be 31-39 lb.-ft. (42-53 N-m).
5. Inspect bearing support for cracks, bends, breaks, and damaged threads.

d. REPAIR

Restore damaged bearing support (6) threads using screw threading set.

e. ASSEMBLY**NOTE**

Ball bearings must be assembled with end opposite retaining ring groove entering bearing support first.

1. Using remover and installer and arbor press, install ball bearing (3) in bearing support (6) until bottom edge of retaining ring groove is flush with bearing support boss.
2. Using retaining ring pliers, install retaining ring (2) in bearing support (6) and ball bearing (3).
3. Using remover and installer and arbor press, install ball bearing (22) in bearing support (6) until bottom edge of retaining ring groove is flush with bearing support boss.
4. Using retaining ring pliers, install retaining ring (21) in bearing support (6) and ball bearing (22).
5. Using arbor press, install countershaft (8) in ball bearing (22) until retaining ring groove is visible.

8-4. TRANSMISSION COUNTERSHAFT AND BEARING SUPPORT MAINTENANCE (Con't).

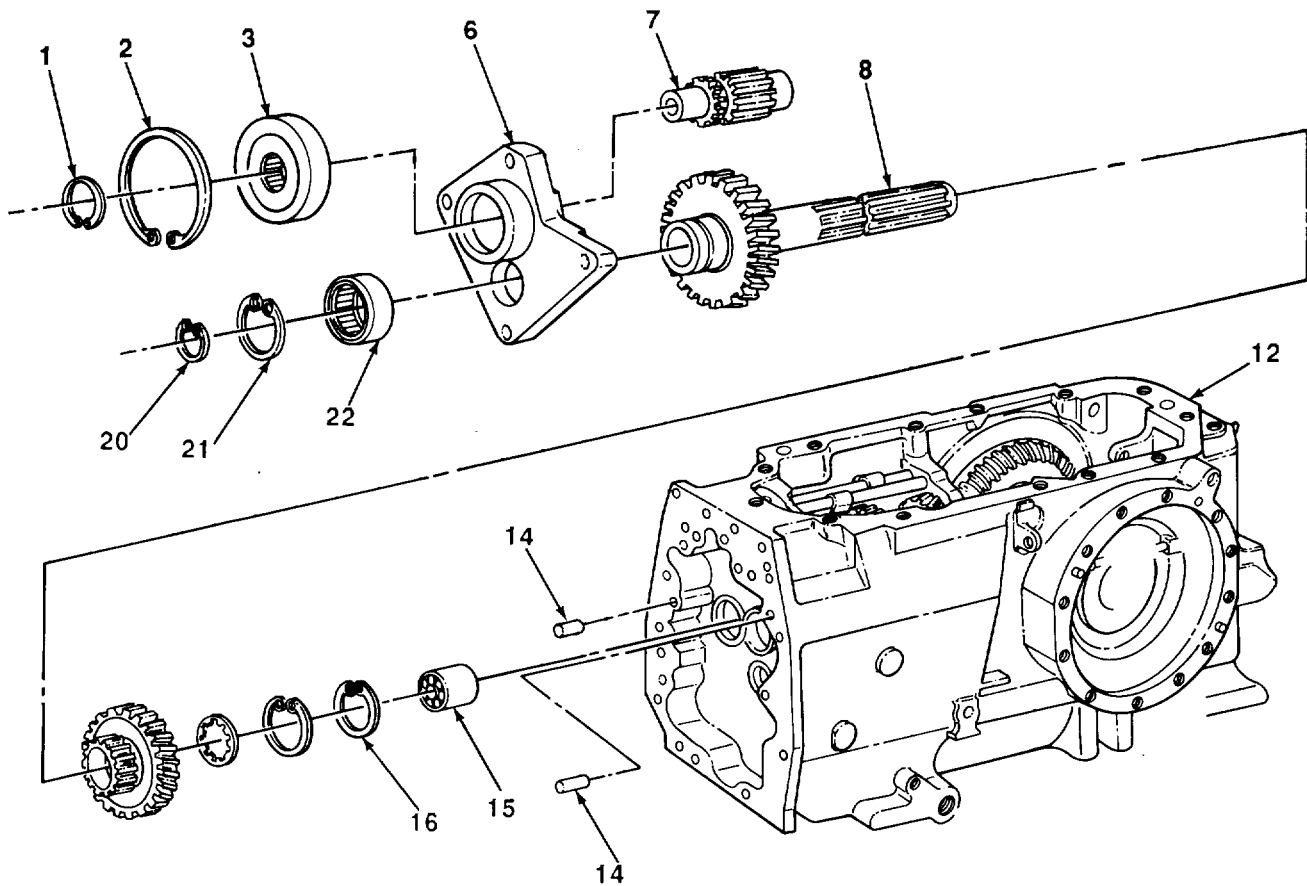

6. Using retaining ring pliers, install retaining ring (20) in ball bearing (22) and countershaft (8).
7. Using arbor press, install helical gearshaft (7) in ball bearing (3) until retaining ring groove is visible.
8. Using retaining ring pliers, install retaining ring (1) in ball bearing (3) and helical gearshaft (7).

f. INSTALLATION**NOTE**

Perform step 1 only if sleeve bushings were removed.

1. Tap sleeve bushings (14) in place in transmission (12).
2. Install needle bearing (15) in transmission (12).
3. Using retaining ring pliers, install retaining ring (16) in needle bearing (15) and transmission (12).

TA701370

8-4. TRANSMISSION COUNTERSHAFT AND BEARING SUPPORT MAINTENANCE (Con't).

4. With the aid of an assistant, install countershaft (8) with assembled bearing support (6), retaining ring (17), thrust washer bearing (18), low range bevel gear (19), sleeve (11), thrust washer bearing (10), collar (9), two plugs (27), springs (26), and spacer rings (25) in transmission (12), needle bearing (15), and drive gear (13). Collar gear teeth must align with thrust washer bearings (18 and 10).
5. Position bearing support (6) with assembled parts in place in transmission (12). Tap bearing support until seated on sleeve bushings (14) and transmission.
6. Turn thrust washer bearing (18) until splines align with countershaft (8), then slide thrust washer bearing on countershaft.
7. Using retaining ring pliers, install retaining ring (17) in groove of countershaft (8).
8. Install two screws (23), screws (4), two new special washers (5), and clamp (24) in bearing support (6) and transmission (12). Bend locking tabs of clam against heads of screws (23).

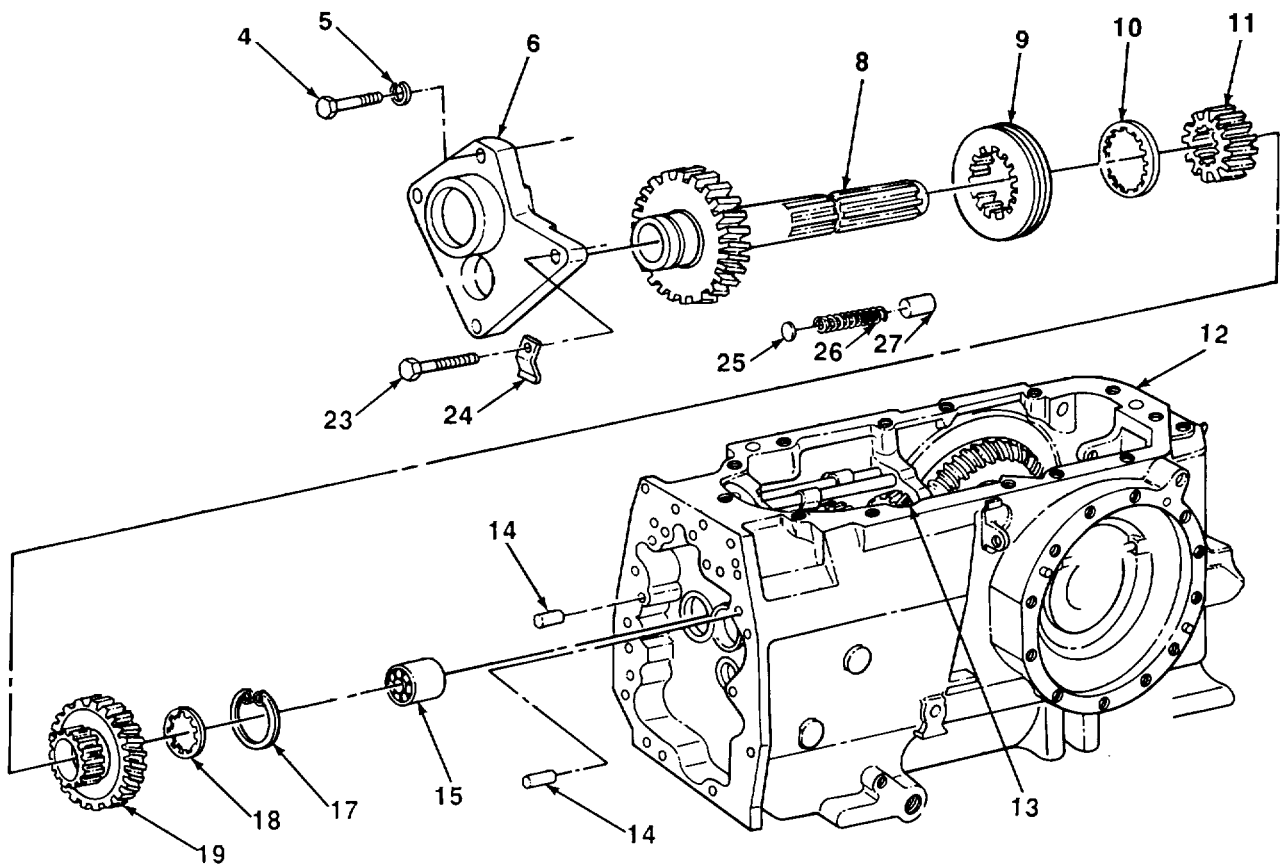

FOLLOW-ON TASKS:

- Install gear shifters and shifter shafts (see paragraph 8-10).

8-5. TRANSMISSION DRIVE SHAFT MAINTENANCE.*This Task Covers:*

- | | | | |
|----|-------------------------|----|--------------|
| a. | Removal | d. | Assembly |
| b. | Disassembly | e. | Installation |
| c. | Cleaning and Inspection | | |

*Initial Setup:***Equipment Conditions:**

- Transmission countershaft and bearing support removed (see paragraph 8-4).

Tools/Test Equipment:

- General mechanic's tool kit
- Field automotive shop set

References:

- TM 9-214

Materials/Parts:

- Rags (Item 28, Appendix B)
- Dry cleaning solvent (Item 31, Appendix B)
- Shim, 0.003 in. thick (as required)
- Shim, 0.005 in. thick (as required)
- Shim 0.00 in. thick (as required)
- Shim, 0.010 in. thick (as required)

General Safety Instructions:

- Dry cleaning solvent is flammable and must not be used near open flame. Use only in a well-ventilated area.

a. REMOVAL

1. Using pry bar and dial indicator, move drive shaft (10) and assembled parts back and forth in transmission (7) and record end play. End play must be 0.004-0.006 in. (0.102-0.152 mm).

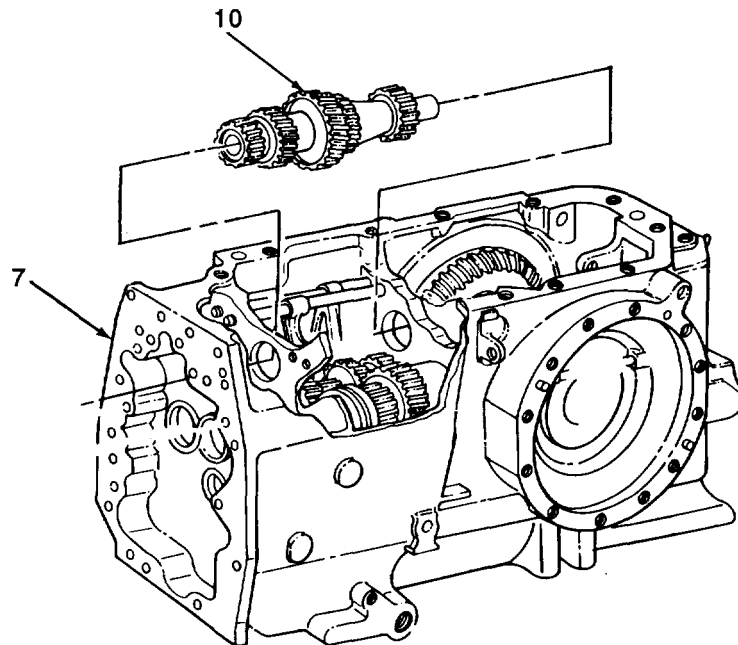

8-5. TRANSMISSION DRIVE SHAFT MAINTENANCE (Con't).

2. Slide shaft collar (1) off drive shaft (10). Bend tabs of three lockplates (3) away from heads of screws (2, 15, and 16).
3. Remove screws (2, 15, and 16) and lockplates (3) from bearing retainer (4) and transmission (7).

NOTE

Record number and thickness of shims removed to ensure proper spacing during Installation.

4. Pry bearing retainer (4) and shims (5) from transmission (7) and bearing cup (6).
5. Tap drive shaft (10) forward until bearing cup (6) is loose from transmission (7). Remove bearing cup from driveshaft and assembled parts.
6. Remove drive shaft (10) with assembled parts from transmission (7), bearing cup (12), and two gears (13 and 14).
7. Using mechanical gear and bearing puller kit, remove bearing cup (12) from transmission (7).

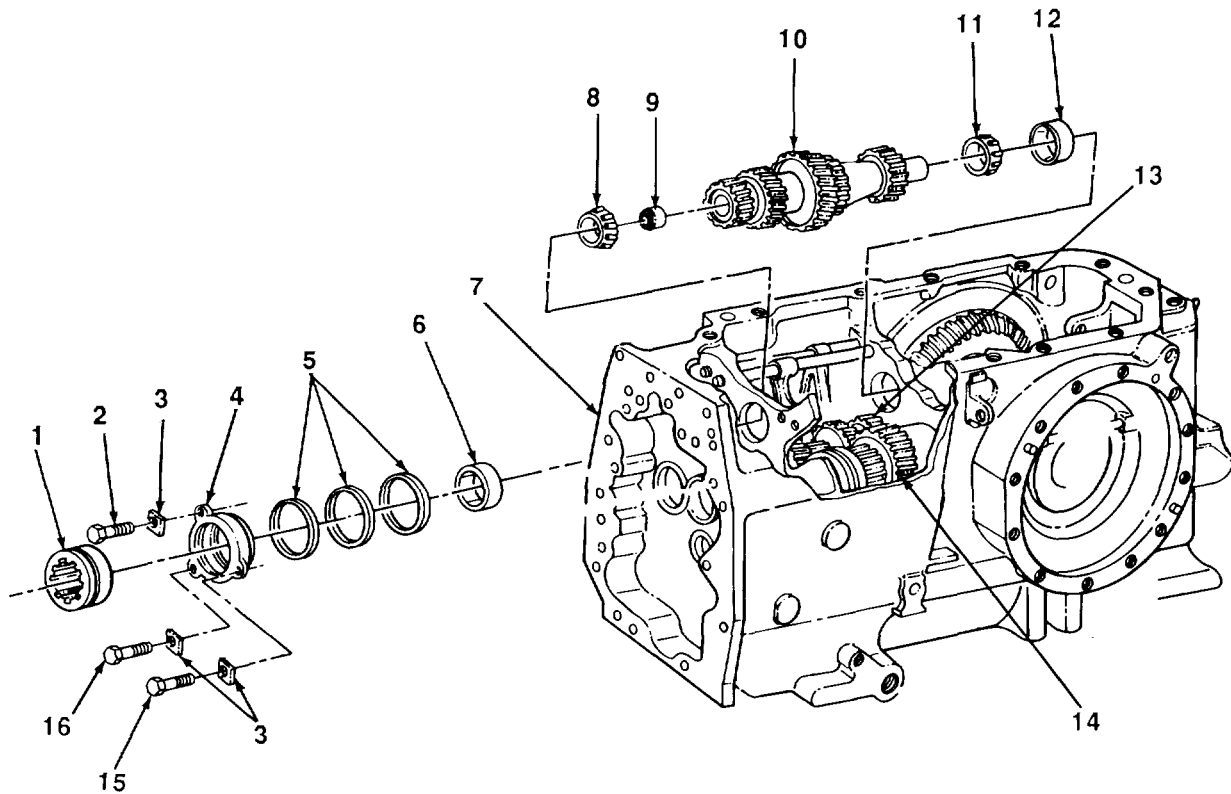

8-5. TRANSMISSION DRIVE SHAFT MAINTENANCE (Con't).

b. DISASSEMBLY

1. Remove needle roller bearing (9) from drive shaft (10).
2. Using mechanical gear and bearing puller kit, remove two tapered roller bearings (8 and 11) from drive shaft (10).

c. CLEANING AND INSPECTION**WARNING**

Dry cleaning solvent, P-D-680, is toxic and flammable. Always wear protective goggles and gloves, and use only in a well-ventilated area. Avoid contact with skin, eyes, and clothes, and DO NOT breathe vapors. DO NOT use near open flame or excessive heat. The solvent's flash point is 100°F-1380F (38°C-59°C). If you become dizzy while using cleaning solvent, immediately get fresh air and medical help. If solvent contacts eyes, immediately wash your eyes and get medical aid.

1. Clean all metal parts with dry cleaning solvent. Dry thoroughly with clean, dry rags.
2. Inspect roller bearings (see TM 9-214).
3. Inspect drive shaft for cracks, breaks, and damaged gear teeth. Replace if defective.
4. Inspect shaft collar for cracks, breaks, and damaged splines. Replace if defective.
5. Inspect all other metal parts for cracks, breaks, abnormal bends, and damaged threads. Replace defective parts.

d. ASSEMBLY

1. Using remover and installer and arbor press, install tapered roller bearing (8) on drive shaft (10).
2. Using remover and installer and arbor press, install tapered roller bearing (11) on drive shaft (10).
3. Position needle roller bearing (9) in drive shaft (10).

e. INSTALLATION

1. Using remover and installer and ball-peen hammer, drive bearing cup (12) in transmission (7) until seated.
2. Position drive shaft (10) with assembled parts in place in transmission (7), bearing cup (12), and two gears (13).
3. Using remover and installer and ball-peen hammer, drive bearing cup (6) in transmission (7).
4. Position bearing retainer (4) and same number and thickness of shims (5) as noted during removal in place on
5. Install three screws (2, 15, and 16) and lockplates (3) in bearing retainer (4) and transmission (7). Torque screws to 35 lb.-ft. (47 N•m).

8-5. TRANSMISSION DRIVE SHAFT MAINTENANCE (Con't).**NOTE**

If all parts are original, skip step 6.

6. Using pry bar and dial indicator, move drive shaft (10) and assembled parts back and forth in transmission (7) and record end play. End play must be 0.004-0.006 in. (0.102-0.152 mm).

NOTE

If end play recorded in step 6 is correct, skip steps 7 and 8.

7. Remove three screws (2, 15, and 16), lockplates (3), bearing retainer (4), and shims (5) from bearing retainer and transmission (7).
8. If end play recorded in step 6 was less than 0.004 in. (0.102 mm), remove one shim (5) and repeat steps 5 and 6. If end play recorded in step 6 was more than 0.006 in. (0.152 mm), add one shim and repeat steps 5 and 6.
9. Bend tabs of lockplates (3) against heads of three screws (2, 15, and 16).
10. slide shaft collar (1) in place on drive shaft (10).

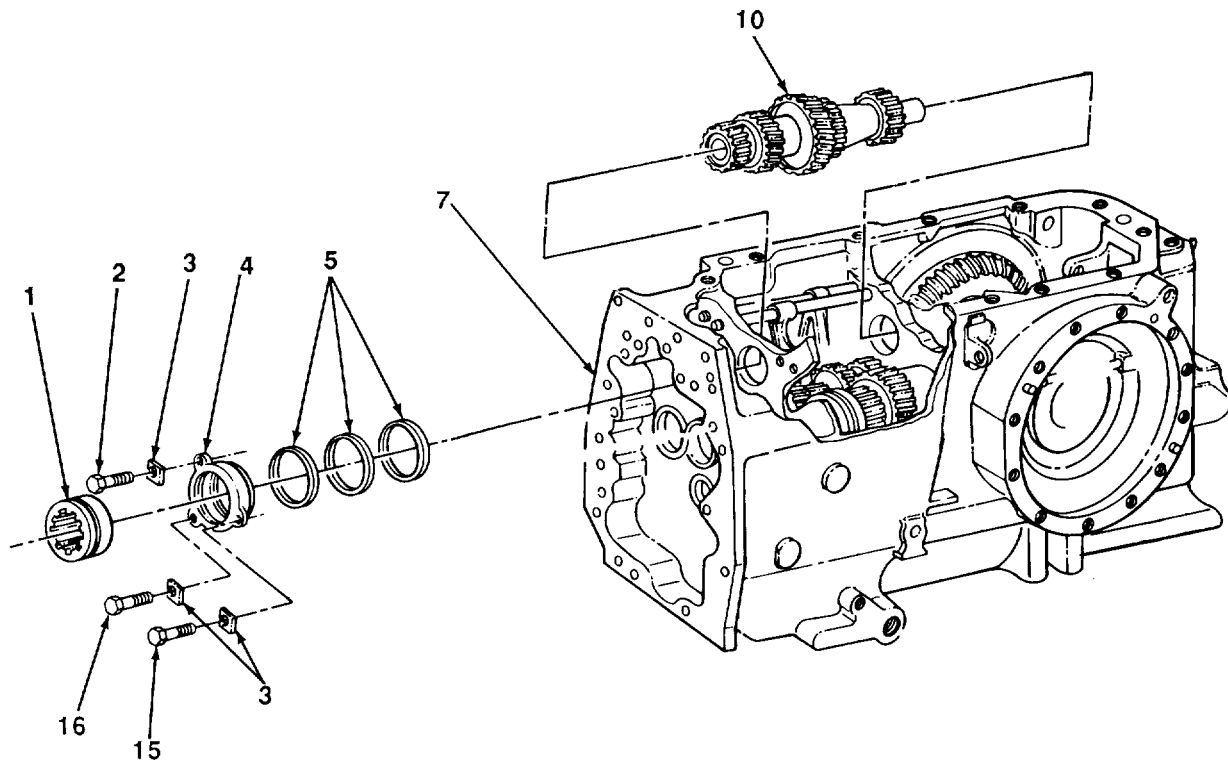
**FOLLOW-ON TASKS:**

- Install transmission countershaft and bearing support (see paragraph 8-4).

TA701374

8-6. DIFFERENTIAL DRIVE SHAFT ASSEMBLY MAINTENANCE.

This Task Covers:

- | | |
|----------------------------|-----------------|
| a. Removal | c. Repair |
| b. Cleaning and Inspection | d. Installation |
-

*Initial Setup:***Equipment Conditions:**

- Transmission drive shaft removed (see paragraph 8-5).

Tools/Test Equipment:

- General mechanic's tool kit
- Field automotive shop set

References:

- TM 9-214

Materials/Parts:

- Rags (Item 28, Appendix B)
- Dry cleaning solvent (Item 31, Appendix B)
- Shim, 0.002 in. thick (as required)
- Shim, 0.005 in. thick (as required)
- Shim, 0.010 in. thick (as required)

General Safety Instructions:

- Dry cleaning solvent is flammable and must not be used near open flame. Use only in a well-ventilated area.
-

8-6. DIFFERENTIAL DRIVE SHAFT ASSEMBLY MAINTENANCE (Con't).

a. REMOVAL

- 1. Wedge a clean rag between gear teeth and remove special nut (1) and washer (2) from drive shaft (20). Remove rag from gears.
- 2. Remove differential assembly (see paragraph 8-7).
- 3. Remove bearing cone (3) from drive shaft (20).

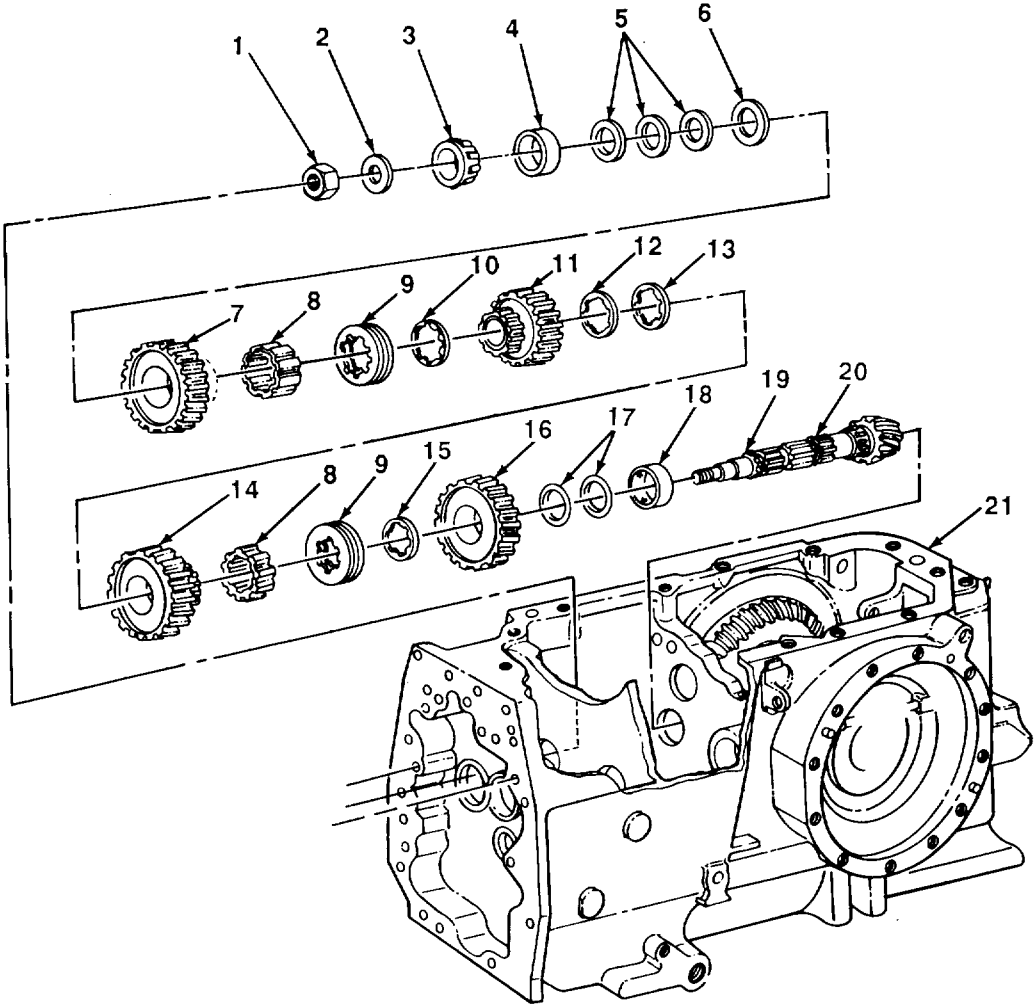

8-6. DIFFERENTIAL DRIVE SHAFT ASSEMBLY MAINTENANCE (Con't).**NOTE**

Record number and thickness of shims and position of parts to ensure proper installation.

4. Remove shims (5), sleeve spacer (6), third and seventh speed gear (16), fourth and eighth speed gear (14), second and sixth speed gear (11), first and fifth speed gear (7), two shaft collars (9), two shifter collar sleeves (8), four thrust washer bearings (10, 12, 13, and 15), shims or ring spacers (17), bearing cone (19), and drive shaft (20) from transmission (21).
5. Using mechanical gear and bearing puller kit, remove two bearing cups (4 and 18) from transmission (21).

b. CLEANING AND INSPECTION

1. Clean and inspect bearings (see TM 9-214).

WARNING

Dry cleaning solvent, P-D-680, is toxic and flammable. Always wear protective goggles and gloves, and use only in a well-ventilated area. Avoid contact with skin, eyes, and clothes, and DO NOT breathe vapors. DO NOT use near open flame or excessive heat. The solvent's flash point is 100°F-138°F (38°C-59°C). If you become dizzy while using cleaning solvent, immediately get fresh air and medical help. If solvent contacts eyes, immediately wash your eyes and get medical aid.

2. Clean all other metal parts with dry cleaning solvent. Dry thoroughly with clean, dry rags.
3. Position bearing cup (4) in place on bearing cone (3). Using vernier caliper, measure assembled width and record reading. Nominal width should be 1.446 in. (36.728 mm). Remove bearing cup from bearing cone.

NOTE

Differential drive shaft and differential ring gear are a matched set. If drive shaft is defective, ring gear must also be replaced (see paragraph 8-7).

4. Inspect drive shaft, four speed gears, two shaft collars, two shifter collar sleeves, and four thrust washer bearings for cracks, breaks, and damaged teeth or splines. Replace if defective.
5. Inspect all other metal parts for cracks, breaks, and abnormal bends. Replace if defective.
6. Inspect drive shaft for damaged threads.

c. REPAIR

Restore damaged drive shaft (20) threads using screw threading set.

d. INSTALLATION

1. Add reading recorded in step 3 of cleaning and inspection to dimension etched on face of bevel pinion gear of drive shaft (20).
2. Record dimension etched on top rear of transmission (21). If dimension is not found etched in transmission, use 7.813 in. (198.450 mm).

8-6. DIFFERENTIAL DRIVE SHAFT ASSEMBLY MAINTENANCE (Con't).

- 3. Subtract reading in step 1 from reading in step 2. The result is the total thickness of shims (5) to be placed on drive shaft (20) between bearing cup (4) and first and fifth speed gear (7).
- 4. Using installer and ball-peen hammer, install bearing cups (4 and 18) in transmission (21).
- 5. Install shims (5), sleeve spacer (6), third and seventh speed gear (16), fourth and eighth speed gear (14), second and sixth speed gear (11), first and fifth speed gear (7), two shaft collars (9), two shifter collar sleeves (8), four thrust washer bearings (10, 12, 13, and 15), shims or ring spacers (17), bearing cone (19), and drive shaft (20) in two bearing cups (4 and 18).
- 6. Position bearing cone (3) in place on drive shaft (20) and bearing cup (4).

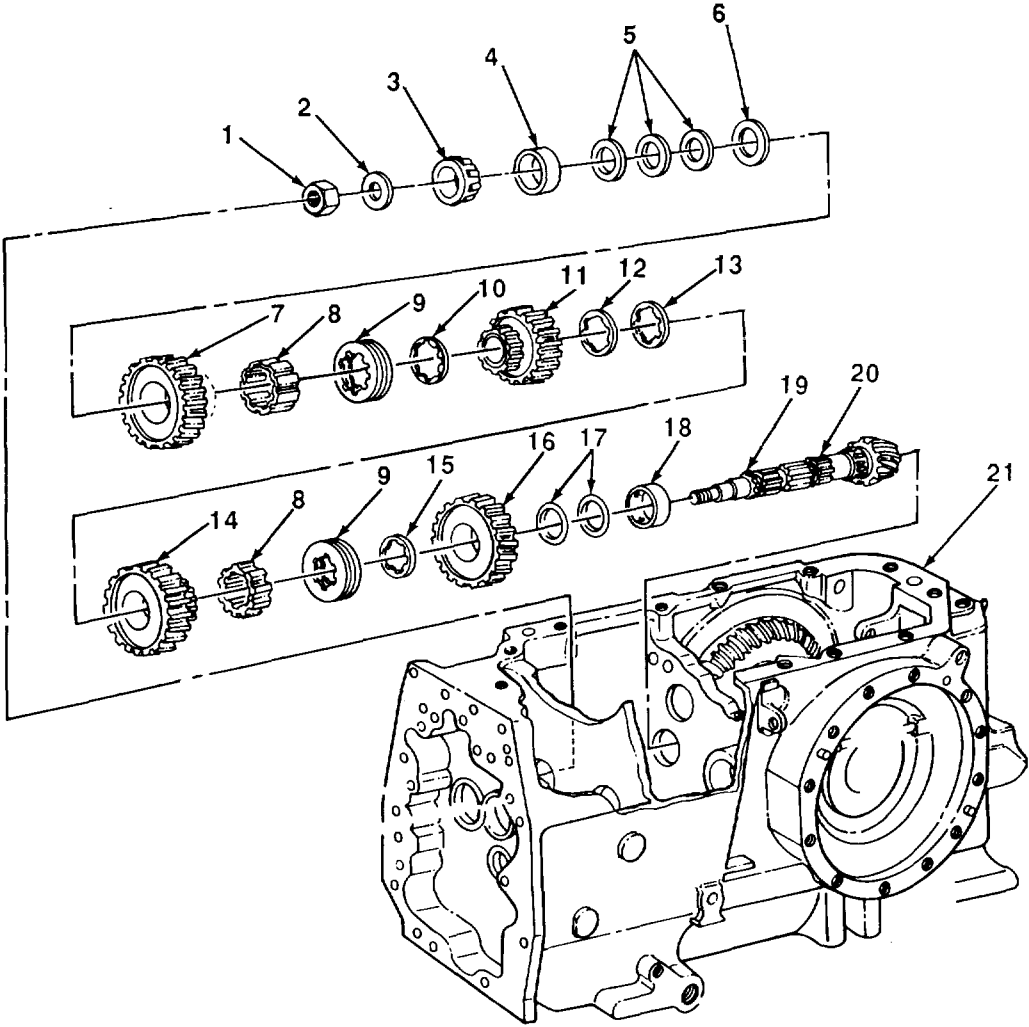

8-6. DIFFERENTIAL DRIVE SHAFT ASSEMBLY MAINTENANCE (Con't).

7. Install differential assembly (see paragraph 8-7).
8. Wedge a clean rag between gear teeth. Install special nut (1) and washer (2) on drive shaft (20). Torque special nut to 160 lb.-ft. (217 N•m). Remove rag from gears.
9. Using dial indicator and pry bar, move drive shaft (20) with assembled parts back and forth and record end play.
10. End play must be 0.006 in. (0.152 mm) on loader backhoes with serial numbers 235786-235999. End play must be 0.002-0.005 in. (0.051-0.127 mm) on loader backhoes with serial numbers 319995-342573.
11. Using torque wrench and socket wrench adapter, turn drive shaft (20) with assembled parts one complete revolution and record rolling torque. Rolling torque must be 10-20 lb.-in. (1.1-2.3 N-m).

NOTE

If readings recorded in steps 10 and 11 are as specified, skip steps 12 through 17.

12. Wedge a clean rag between gear teeth and remove special nut (1) and washer (2) from drive shaft (20).
13. Remove bearing cone (3) from drive shaft (20) and bearing cup (4).
14. Slide drive shaft (20) rearward to access shims (5).
15. If end play reading in step 10 is higher than specified, add shims (5) as required. If reading is lower, remove shims as required.
16. If rolling torque reading in step 11 is higher than specified, add shims (5) as required. If reading is lower, remove shims as required.
17. Install bearing cone (3), special nut (1), and washer (2) on drive shaft (20). Torque special nut to 160 lb.-ft. (217 N•m).
18. Stake special nut (1) in place on drive shaft (20).

FOLLOW-ON TASKS:

- Install transmission drive shaft (see paragraph 8-5).

8-7. DIFFERENTIAL ASSEMBLY MAINTENANCE.

This Task Covers:

- | | |
|----------------------------|-----------------|
| a. Removal | d. Repair |
| b. Disassembly | e. Assembly |
| c. Cleaning and Inspection | f. Installation |
-

Initial Setup:

Equipment Conditions:

- Transmission removed (see paragraph 8-2).
- Transmission top cover removed (see paragraph 8-12 or 8-13).
- Differential lock mechanism removed (see paragraph 8-9).
- Parking brake band and lining removed (see paragraph 10-1).

Materials/Parts:

- Prussian blue dye (Item 14, Appendix B)
- Hydraulic fluid (Item 15, Appendix B)
- Rags (Item 28, Appendix B)
- Dry cleaning solvent (Item 31, Appendix B)
- Shim, 0.003 in. thick (as required)
- Shim, 0.005 in. thick (as required)
- Shim, 0.010 in. thick (as required)

Tools/Test Equipment:

- General mechanic's tool kit
- Field automotive shop set

General Safety Instructions:

- Dry cleaning solvent is flammable and must not be used near open flame. Use only in a well-ventilated area

References:

- TM 9-214
-

a. REMOVAL**WARNING**

Use extreme caution when handling heavy parts. Lifting device is required when parts weigh over 50 lb. (23 kg) for a single person lift, over 100 lb. (45 kg) for a two person lift, and over 150 lb. (68 kg) for a three or more person lift. Keep clear of heavy parts supported only by lifting device. Failure to follow this warning may cause serious injury or death to personnel.

1. Attach lifting device to differential gear assembly (4).
2. Remove ten bolts (1) from left and right differential quills (2 and 6).

NOTE

Record position and number of shims for each differential quill to ensure proper installation.

3. Pry left and right differential quills (2 and 6) and shims (3) from differential gear assembly (4) and transmission (5).
4. Using lifting device, remove differential gear assembly (4) from transmission (5). Remove lifting device from differential gear assembly.

8-7. DIFFERENTIAL ASSEMBLY MAINTENANCE (Con't).

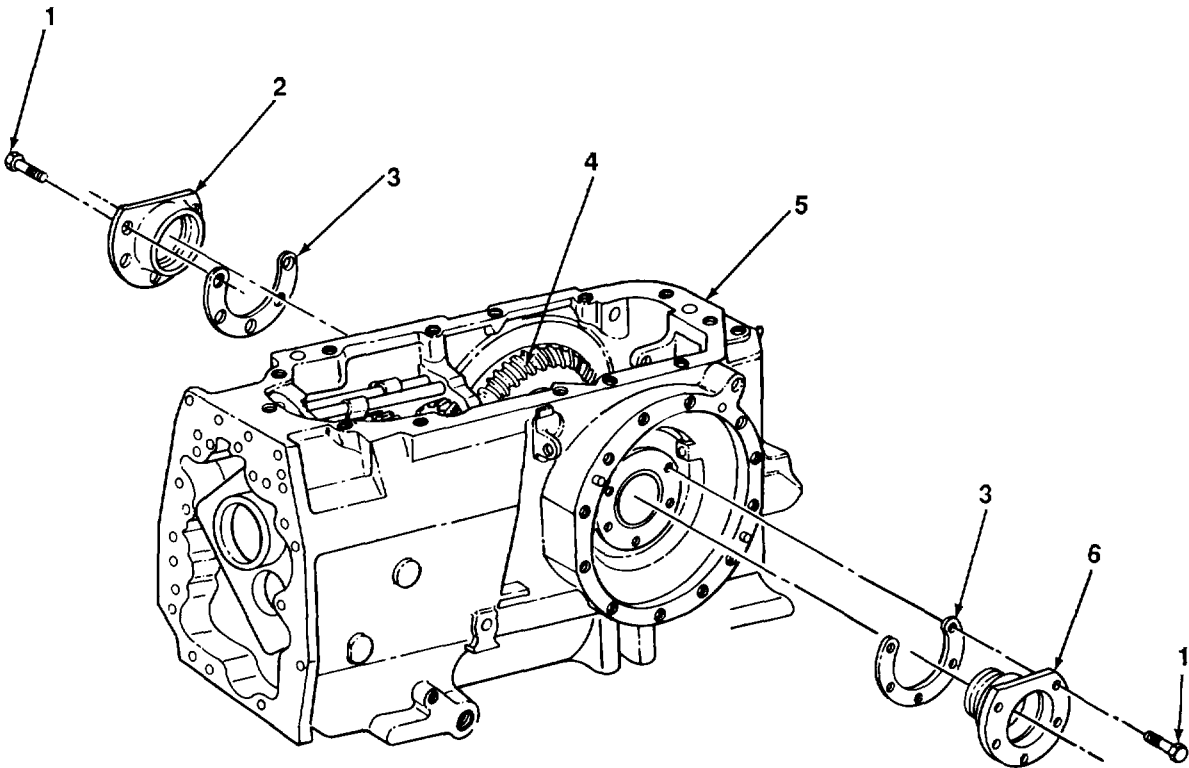

b. DISASSEMBLY

- 1. Using ball-peen hammer and brass drift, remove bearing cups (7 and 8) from left and right differential quills (2 and 6).

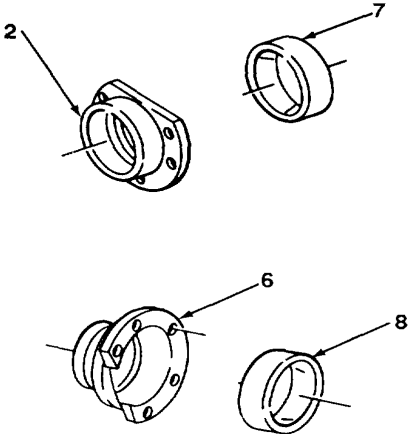

8-7. DIFFERENTIAL ASSEMBLY MAINTENANCE (Con't).

2. Using mechanical gear and bearing puller kit, remove bearing cone (9) from parking brake drum (10) and housing (12).
3. Remove parking brake drum (10) from housing (12).
4. Using mechanical gear and bearing puller kit, remove bearing cone (20) from housing (18).
5. Remove eight bolts (11) securing two housings (12 and 18). Remove housing (18) with assembled bevel gear (16) from housing (12). Slide bevel gear out of housing (18).
6. Remove four bevel gears (14), two shouldered shafts (15), and bevel gear (13) from housing (12).

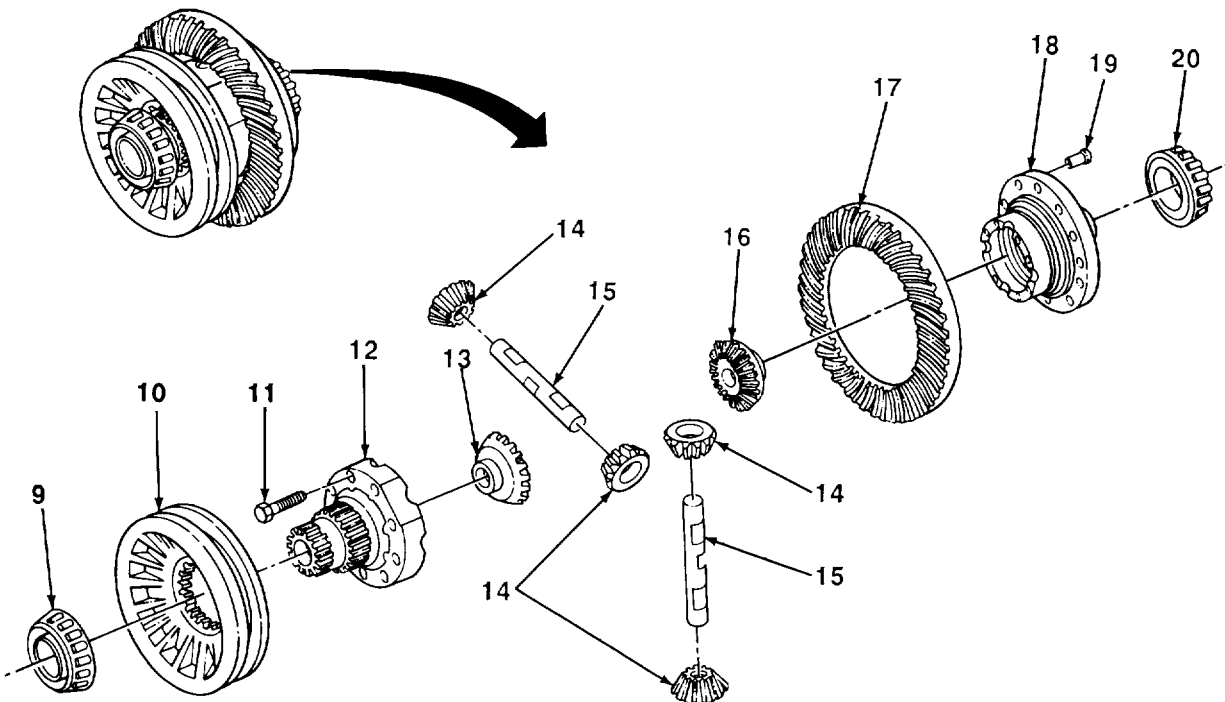
**CAUTION**

Do not remove differential gear housing rivets unless differential gear housing or rivets are damaged. Removal will damage parts.

7. Using cold chisel and ball-peen hammer, cut off head of rivet (19) to be replaced.
8. Using punch and ball-peen hammer, drive rivet (19) out of differential ring gear (17) and housing (18). Discard rivet. Repeat steps 7 and 8 for each rivet to be removed.
9. Remove differential ring gear (17) from housing (18).

TA701378

8-7. DIFFERENTIAL ASSEMBLY MAINTENANCE (Con't).**c. CLEANING AND INSPECTION**

1. Clean and inspect bearings (see TM 9-214).

WARNING

Dry cleaning solvent, P-D-680, is toxic and flammable. Always wear protective goggles and gloves, and use only in a well-ventilated area. Avoid contact with skin, eyes, and clothes, and DO NOT breathe vapors. DO NOT use near open flame or excessive heat. The solvent's flash point is 1000F-138°F (38°C-59°C). If you become dizzy while using cleaning solvent, immediately get fresh air and medical help. If solvent contacts eyes, immediately wash your eyes and get medical aid.

2. Clean all other metal parts with dry cleaning solvent. Dry thoroughly with clean, dry rags.

NOTE

Differential ring gear and differential drive shaft are a matched set. If differential ring gear is defective, differential drive shaft must also be replaced (see paragraph 8-6).

3. Inspect all gears and shafts for cracks, breaks, and damaged teeth or splines. Replace if defective.
4. Inspect parking brake drum for cracks, breaks, grooves, and scoring. Replace if defective.
5. Check for any loose, missing, or damaged rivets. Replace as required.
6. Inspect all other metal parts for cracks, breaks, abnormal bends, and damaged threads.

d. REPAIR

Restore any damaged housing (12 or 18) threads using screw threading set.

e. ASSEMBLY**NOTE**

Perform steps 1 and 2 only if differential ring gear or rivets were removed.

1. Install differential ring gear (17) in housing (18).
2. Using blind riveter, install new rivet (19) in housing (18) and differential ring gear (17). Repeat for each rivet to be installed.
3. Install bevel gear (13), two shouldered shafts (15), and four bevel gears (14) on housing (12).
4. Install bevel gear (16) on housing (18).
5. Install housing (18) with assembled bevel gear (16) on housing (12). Install eight bolts (11) in two housings. Torque bolts to 35 lb.-ft. (47 N•m).
6. Using arbor press, install bearing cone (20) on housing (18).
7. Install parking brake drum (10) on housing (12).
8. Using arbor press, install bearing cone (9) on housing (12) and parking brake drum (10).

8-7. DIFFERENTIAL ASSEMBLY MAINTENANCE (Con't).

9. Using arbor press, install bearing cups (7 and 8) in left and right differential quills (2 and 6).

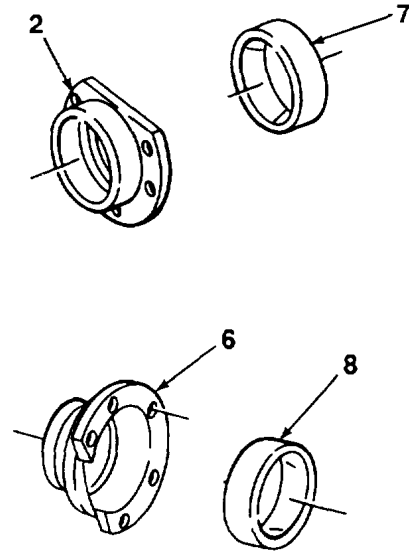
**f. INSTALLATION**

1. Apply a coat of hydraulic fluid to all moving parts of differential gear assembly (4).

WARNING

Use extreme caution when handling heavy parts. Lifting device is required when parts weigh over 50 lb. (23 kg) for a single person lift, over 100 lb. (45 kg) for a two person lift, and over 150 lb. (68 kg) for a three or more person lift. Keep clear of heavy parts supported only by lifting device. Failure to follow this warning may cause serious injury or death to personnel.

2. Attach lifting device to differential gear assembly (4) and lift into position and support in transmission (5).
3. Install left and right differential quills (2 and 6) and the same number of shims (3) as noted during removal on transmission (5) and differential gear assembly (4).
4. Install ten bolts (1) in left and right differential quills (2 and 6) and transmission (5). Torque bolts to 35 lb.-ft. (47 N•m).

NOTE

Differential gear must not be in contact with differential drive shaft during differential bearing preload adjustment. If adjustment cannot be made without gears touching, remove differential drive shaft (see paragraph 8-6). Inspect for damaged parts.

5. Using dial indicator and pry bar, move differential gear assembly (4) from side to side and note end play. End play must be 0.002-0.005 in. (0.051-0.127 mm).

NOTE

If end play is as specified in step 5, skip steps 6 through 8.

6. Remove ten bolts (1) from left and right differential quills (2 and 6) and transmission (5).

8-7. DIFFERENTIAL ASSEMBLY MAINTENANCE (Con't).

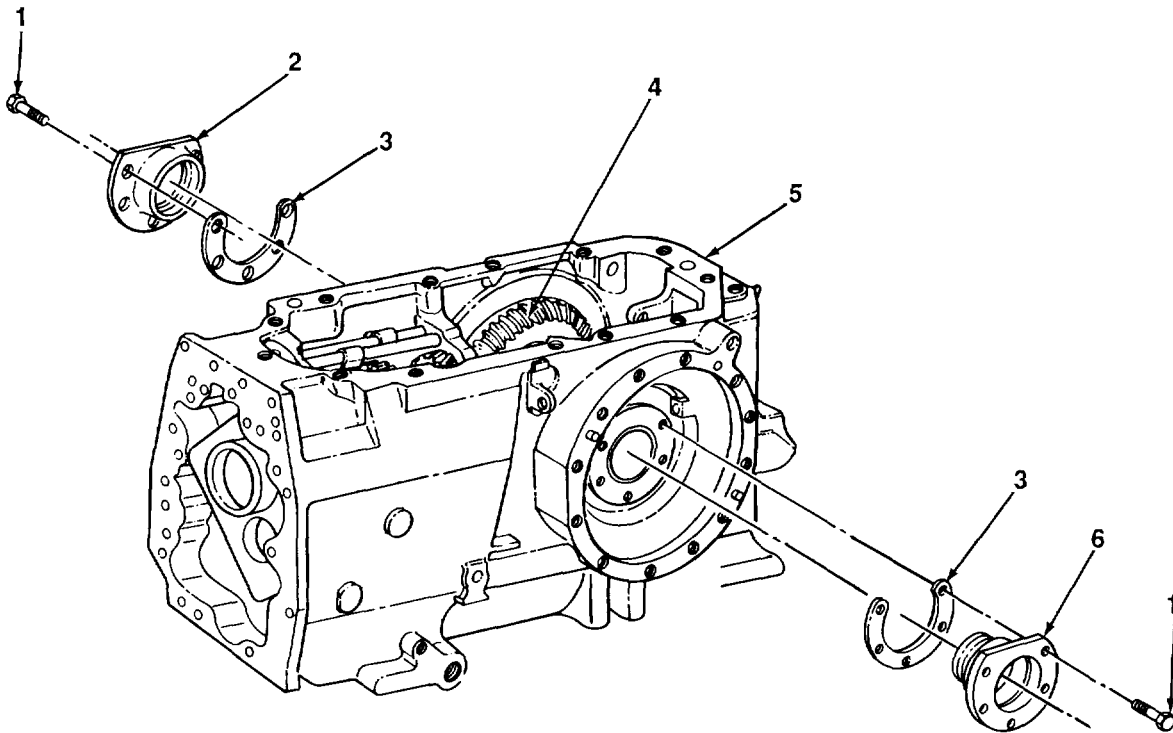

7. Using lifting device, support differential gear assembly (4) and pry left and right differential quills (2 and 6) and shims (3) from differential gear assembly and transmission (5).
8. If end play noted in step 5 was less than 0.002 in. (0.051 mm), remove one shim (3) from each side. If end play was more than 0.005 in. (0.127 mm), add one shim to each side. Install ten bolts (1) in left and right differential quills (2 and 6) and transmission (5). Torque bolts to 35 lb.-ft. (47 N•m).

TA701380

8-7. DIFFERENTIAL ASSEMBLY MAINTENANCE (Con't).

9. Using dial indicator, turn differential drive shaft (21) back and forth and note backlash. Backlash with new parts must be 0.006-0.008 in. (0.152-0.203 mm). Backlash with used parts must not exceed 0.0, 2 in. (0.305 mm) at point of greatest backlash.

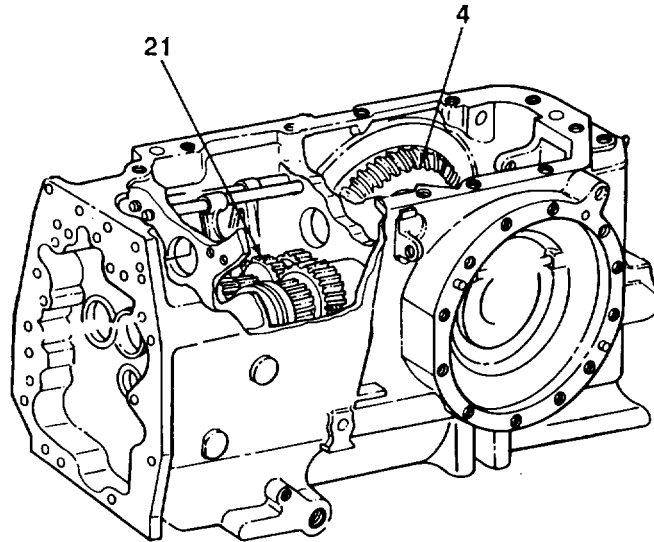
**NOTE**

If backlash in step 9 is as specified, skip steps 10 through 12.

10. Remove ten bolts (1) from left and right differential quills (2 and 6) and transmission (5).
11. Using lifting device, support differential gear assembly (4) and remove left and right differential quills (2 and 6) from differential gear assembly and transmission (5).

NOTE

Do not add or subtract number of shims being used. Subtracting or adding shims to obtain proper backlash will change differential bearing preload adjustment.

12. If backlash noted in step 9 was more than specified, move one shim (3) from left to right side. If backlash was less than specified, move one shim from right to left side. Install ten bolts (1) in left and right differential quills (2 and 6) and transmission (5). Torque bolts to 35 lb.-ft. (47 Nom).
13. Disconnect lifting device from differential gear assembly (4).
14. Apply light coat of Prussian blue dye to contact surfaces of gear teeth of differential gear assembly (4) and differential drive shaft (21).
15. Turn differential drive shaft (21) one full revolution. Using vernier caliper, measure distance between bevel gear end of differential drive shaft and start of tooth pattern.
16. Distance from bevel gear end of differential drive shaft (21) and start of tooth pattern must be 0.120-0.360 in. (3.048-9.144 mm). If distance is not as specified, repeat steps 9 through 16 to determine cause.

TA701381

8-7. DIFFERENTIAL ASSEMBLY MAINTENANCE (Con't).

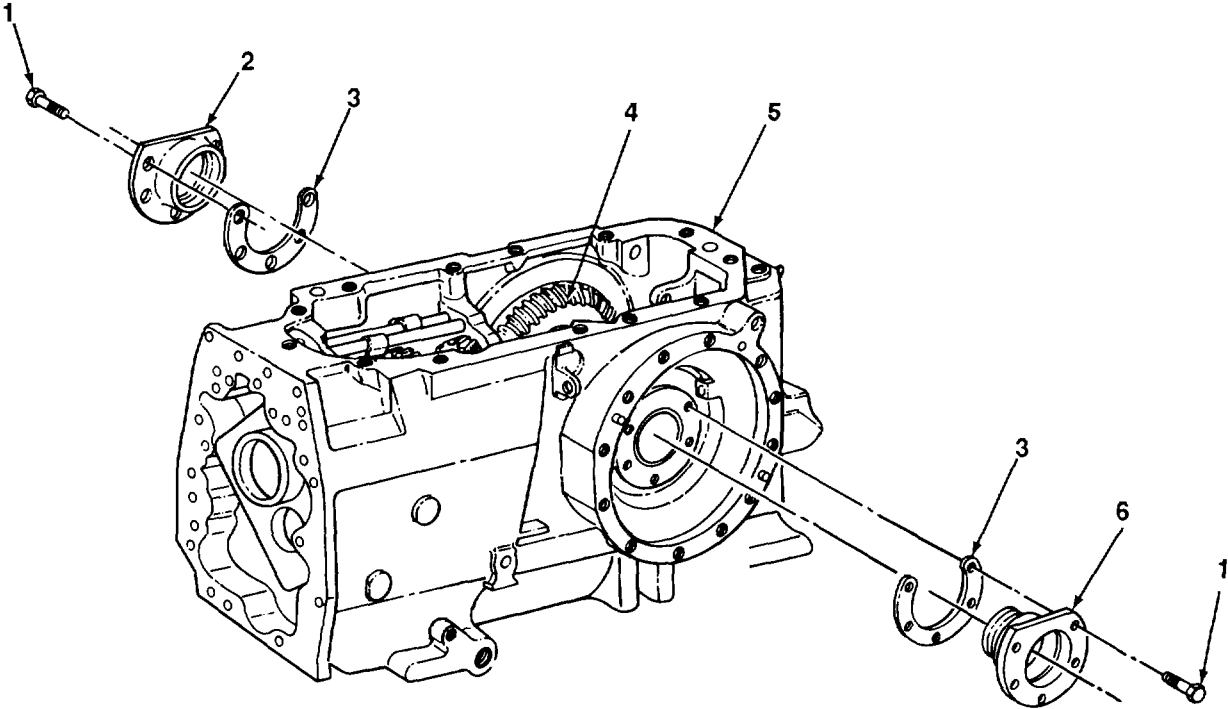

FOLLOW-ON TASKS:

- Install parking brake band and lining (see paragraph 10-1).
- Install transmission top cover (see paragraph 8-12 or 8-13).
- Install differential lock mechanism (see paragraph 8-9).
- Install right rear axle housing (see paragraph 9-3).
- Install transmission (see paragraph 8-2).

TA701382

8-8. DIFFERENTIAL LOCK PEDAL AND LINKAGE MAINTENANCE.

This Task Covers:

- | | |
|----------------------------|-----------------|
| a. Removal | c. Repair |
| b. Cleaning and Inspection | d. Installation |

Initial Setup:

Equipment Conditions:

- Batteries removed (see TM 5-2420-222-20).

Tools/Test Equipment:

- General mechanic's tool kit

Materials/Parts:

- Rags (Item 28, Appendix B)
- Dry cleaning solvent (Item 31, Appendix B)
- One cotter pin

General Safety Instructions:

- Dry cleaning solvent is flammable and must not be used near open flame. Use only in a well-ventilated area.

a. REMOVAL

- Loosen jamnut (2) on pedal (1) and rod (4).
- Remove pedal (1) and jamnut (2) from rod (4).
- Remove cotter pin (6) from pin (5). Discard cotter pin.
- Remove pin (5) from rod (4) and arm (7).
- Remove rod (4) from arm (7) and platform (3).

b. CLEANING AND INSPECTION**WARNING**

Dry cleaning solvent, P-D-680, is toxic and flammable. Always wear protective goggles and gloves, and use only in a well-ventilated area. Avoid contact with skin, eyes, and clothes, and DO NOT breathe vapors. DO NOT use near open flame or excessive heat. The solvent's flash point is 100°F-138°F (38°C-59°C). If you become dizzy while using cleaning solvent, immediately get fresh air and medical help. If solvent contacts eyes, immediately wash your eyes and get medical aid.

- Clean all metal parts with dry cleaning solvent. Dry thoroughly with clean, dry rags.
- Inspect pedal and rod for cracks, breaks, and abnormal bends.
- Inspect rod for damaged threads.

c. REPAIR

Restore damaged rod (4) threads using screw threading set.

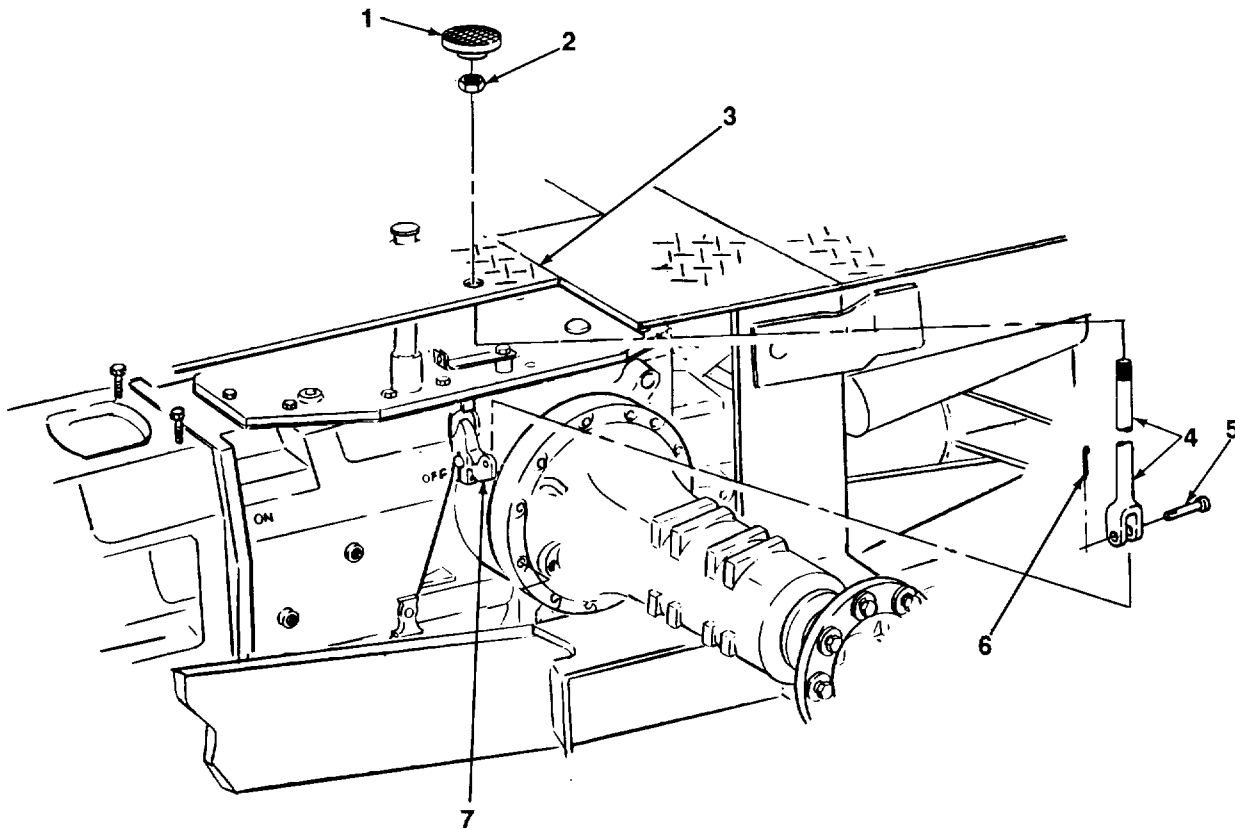
8-8. DIFFERENTIAL LOCK PEDAL AND LINKAGE MAINTENANCE (Con't).**d. INSTALLATION**

1. Install rod (4) through hole in platform (3) and position in place on arm (7).
2. Install pin (5) in rod (4) and arm (7).
3. Install new cotter pin (6) in pin (5).
4. Install jamnut (2) and pedal (1) all the way on rod (4).
5. Hold pedal (1) and tighten jamnut (2) until seated against pedal.

FOLLOW-ON TASKS:

- Install batteries (see TM 5-2420-222-20).

TA701383

8-9. DIFFERENTIAL LOCK MECHANISM MAINTENANCE.*This Task Covers:*

- | | |
|----------------------------|-----------------|
| a. Removal | c. Repair |
| b. Cleaning and Inspection | d. Installation |

*Initial Setup:***Equipment Conditions:**

- Differential lock pedal and linkage removed (see paragraph 8-8).
- Left rear axle housing removed (see paragraph 9-3).

Materials/Parts:

- Rags (Item 28, Appendix B)
- Dry cleaning solvent (Item 31, Appendix B)
- One preformed packing

Tools/Test Equipment:

- General mechanics tool kit
- Field automotive shop set

Personnel Required: Two**General Safety Instructions:**

- Dry cleaning solvent is flammable and must not be used near open flame. Use only in a well-ventilated area.

a. REMOVAL

1. Loosen screw (11) in arm (10).
2. Using hammer and drift, drive shaft (3) rearward until clear of arm (10). Remove arm and key (12) from shaft and transmission (1).
3. Remove plug (4) from shaft (3) and transmission (1).
4. While assistant supports shaft (3), drive shaft rearward until key (5) can be removed from shaft.
5. While assistant supports collar (9), shifter fork (7), and spring (6), pull shaft (3) out of transmission (1), spring, and shifter fork.
6. Remove preformed packing (2) from shaft (3). Discard preformed packing.
7. Remove shifter fork (7) with assembled parts from transmission (1).
8. Remove two shoes (8) and spring (6) from shifter fork (7).

b. CLEANING AND INSPECTION**WARNING**

Dry cleaning solvent, P-D-680, is toxic and flammable. Always wear protective goggles and gloves, and use only in a well-ventilated area. Avoid contact with skin, eyes, and clothes, and DO NOT breathe vapors. DO NOT use near open flame or excessive heat. The solvent's flash point is 100°F-138°F (38°C-59°C). If you become dizzy while using cleaning solvent, immediately get fresh air and medical help. If solvent contacts eyes, immediately wash your eyes and get medical aid.

1. Clean all metal parts with dry cleaning solvent. Dry thoroughly with clean, dry rags.

8-9. DIFFERENTIAL LOCK MECHANISM MAINTENANCE (Con't).

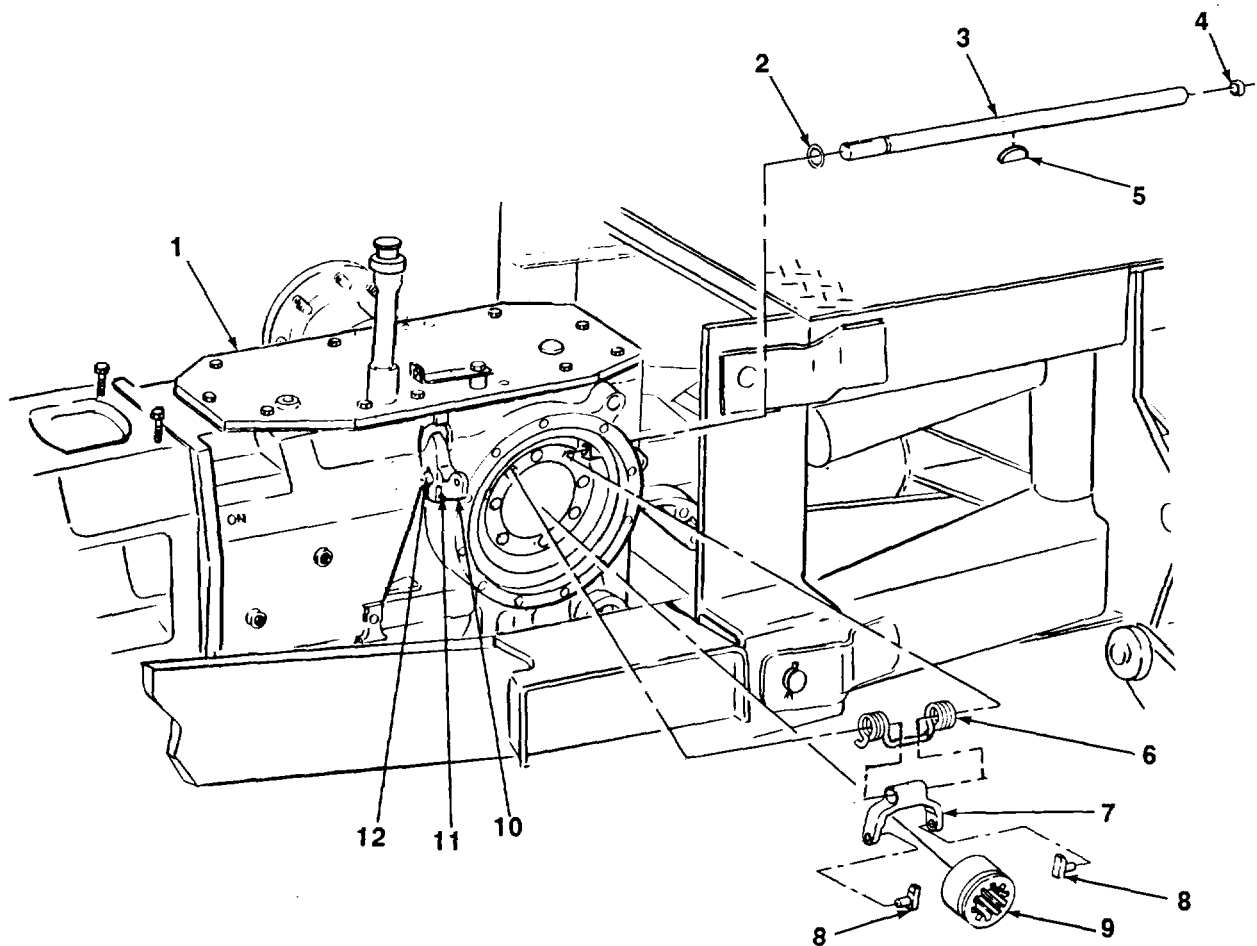

2. Inspect collar for cracks, breaks, and damaged splines.
3. Inspect all other metal parts for cracks, breaks, and abnormal bends.

c. REPAIR

Restore damaged collar (9) splines with smooth-cut flat file.

1. Install spring (6) in place on shifter fork (7). Position two shoes (8) and collar (9) in shifter fork.

d. INSTALLATION

1. Install spring (6) in place on shifter fork (7). Position two shoes (8) and collar (9) in shifter fork.
2. Install shifter fork (7) with assembled parts in place on transmission (1).

TA701384

8-9. DIFFERENTIAL LOCK MECHANISM MAINTENANCE (Con't).

3. While assistant holds shifter fork (7) with assembled parts in place on transmission (1), install shaft (3) in shifter fork and transmission until keyway is accessible.
4. Install key (5) in shaft (3). Install new preformed packing (2) on shaft.
5. While assistant aligns keyway in shifter fork (7) with key (5), tap shaft (3) with assembled key and preformed packing (2) in transmission (1) and shifter fork.
6. While assistant pushes in on collar (9) and shifter fork (7), align arm (10) and key (12) with keyway in end of shaft (3). Install arm on shaft. Tighten screw (11) in arm.
7. Install plug (4) in transmission (1).

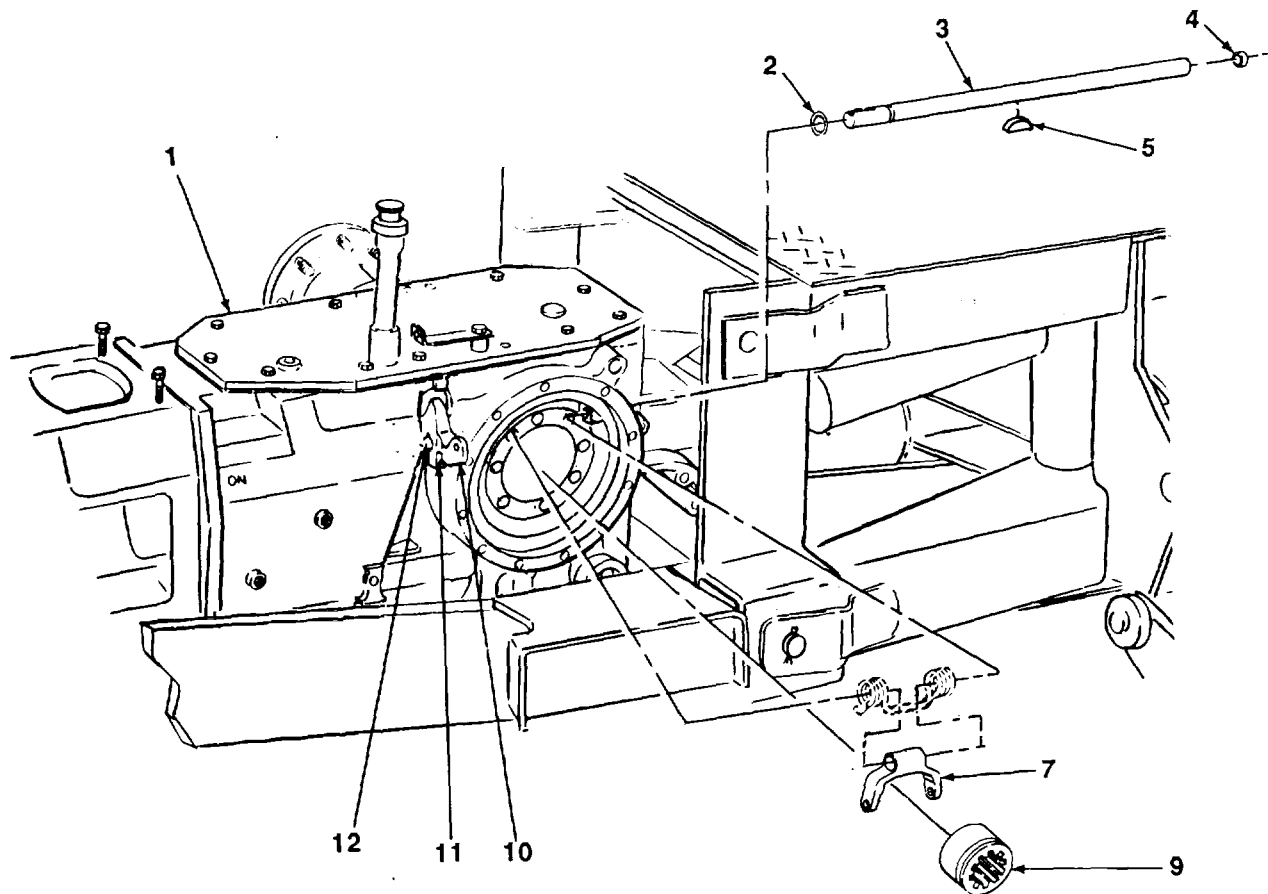
**FOLLOW-ON TASKS:**

- Install left rear axle housing (see paragraph 9-3).
- Install differential lock pedal and linkage (see paragraph 8-8).

TA701385

8-10. GEAR SHIFTERS AND SHIFTER SHAFTS MAINTENANCE.*This Task Covers:*

- | | | |
|----------------------------|----|-----------------|
| a. Removal | c. | Repair |
| b. Cleaning and Inspection | | d. Installation |

*Initial Setup:***Equipment Conditions:**

- Transmission removed (see paragraph 8-2).
- Transmission top cover removed (see paragraph 8-12 or 8-13).

Tools/Test Equipment:

- General mechanic's tool kit
- Field automotive shop set

References

- TM 9-214

Materials/Parts:

- Rags (Item 28, Appendix B)
- Dry cleaning solvent (Item 31, Appendix B)
- Two spring pins

Personnel Required: Two**General Safety Instructions:**

- Dry cleaning solvent is flammable and must not be used near open flame. Use only in a well-ventilated area.

a. REMOVAL

1. Remove pin (9) from shifter fork (10).
2. Remove four drive screws (8) from four shifter forks (5, 6, 7, and 10).

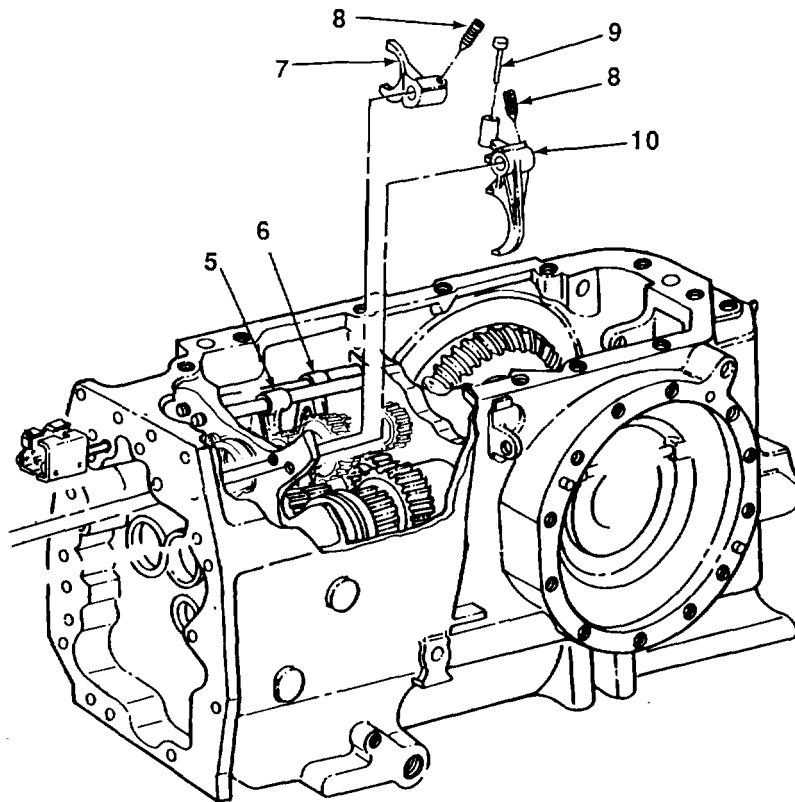

8-10. GEAR SHIFTERS AND SHIFTER SHAFTS MAINTENANCE (Con't)

3. Place remote control lever (4) and high range shaft (2) in neutral position.

CAUTION

Do not turn shafts and remote control lever during removal. Spring ball bearings can become lodged in shifter fork drive screw holes causing damage to parts.

4. While assistant supports shifter fork (10), slide low reverse shaft (17) out of transmission (11) and shifter fork, and catch three ball bearings (15). Remove shifter fork.
5. Drive spring pin (16) out of transmission (11) and expansion plug (13). Remove spring (14) and expansion plug from transmission. Discard spring pin.
6. Place shifter straight shaft (3) into gear to release interlock pin.
7. While assistant supports shifter fork (7), slide high range shaft (2) out of transmission (11) and shifter fork, and catch ball bearing (20), spring (19), and expansion plug (18).
8. Remove spring (1) from high range shaft (2).
9. Remove shifter fork (7) from collar (12).

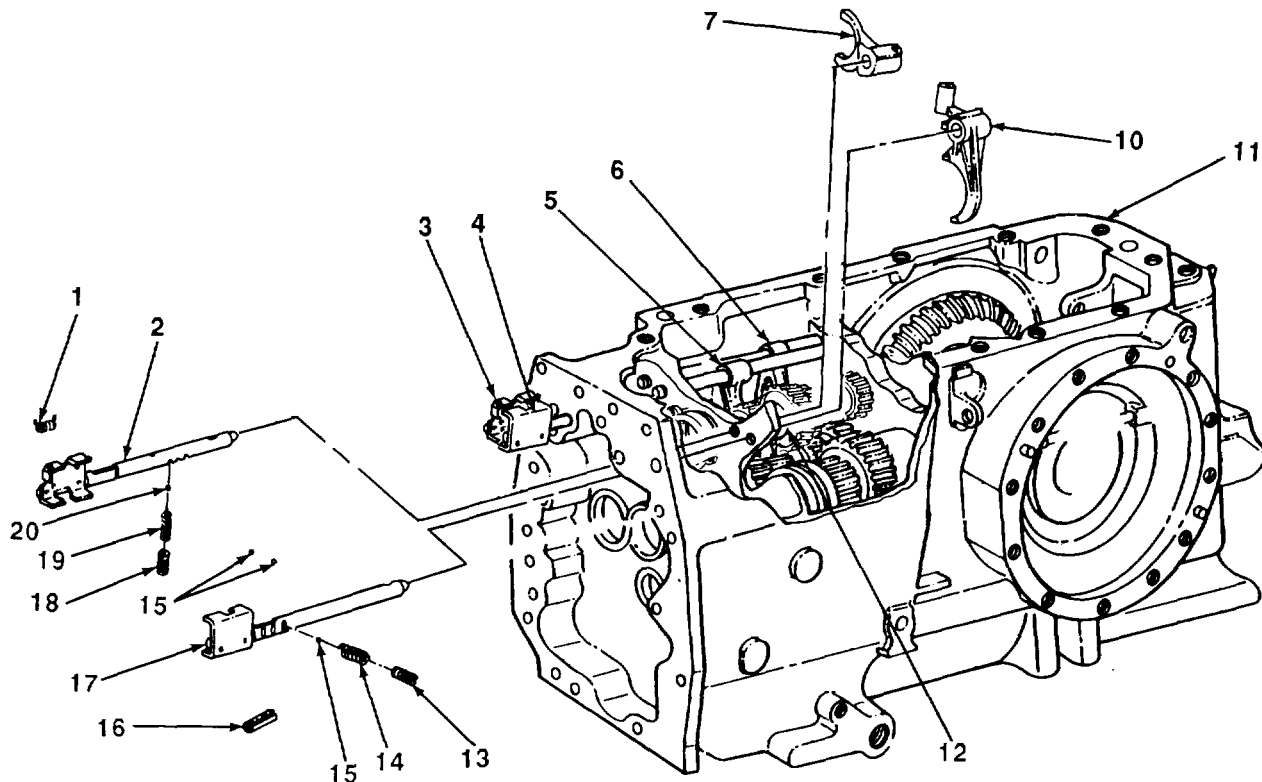

8-10. GEAR SHIFTERS AND SHIFTER SHAFTS MAINTENANCE. (Con't)

10. While assistant supports shifter fork (6), slide shifter straight shaft (3) out of transmission (11) and shifter fork, and catch five ball bearings (29). Remove three ball bearings (23).
11. Remove shifter fork (6) from collar (25).
12. While assistant supports shifter fork (5), slide remote control lever (4) out of transmission (11) and shifter fork, and catch ball bearing (27) and spring (26). Remove shifter fork.
13. Drive spring pin (24) out of transmission (11) and expansion plug (21). Remove spring (22) and expansion plug from transmission and pin (28). Discard spring pin.
14. Slide pin (28) out of transmission (11).

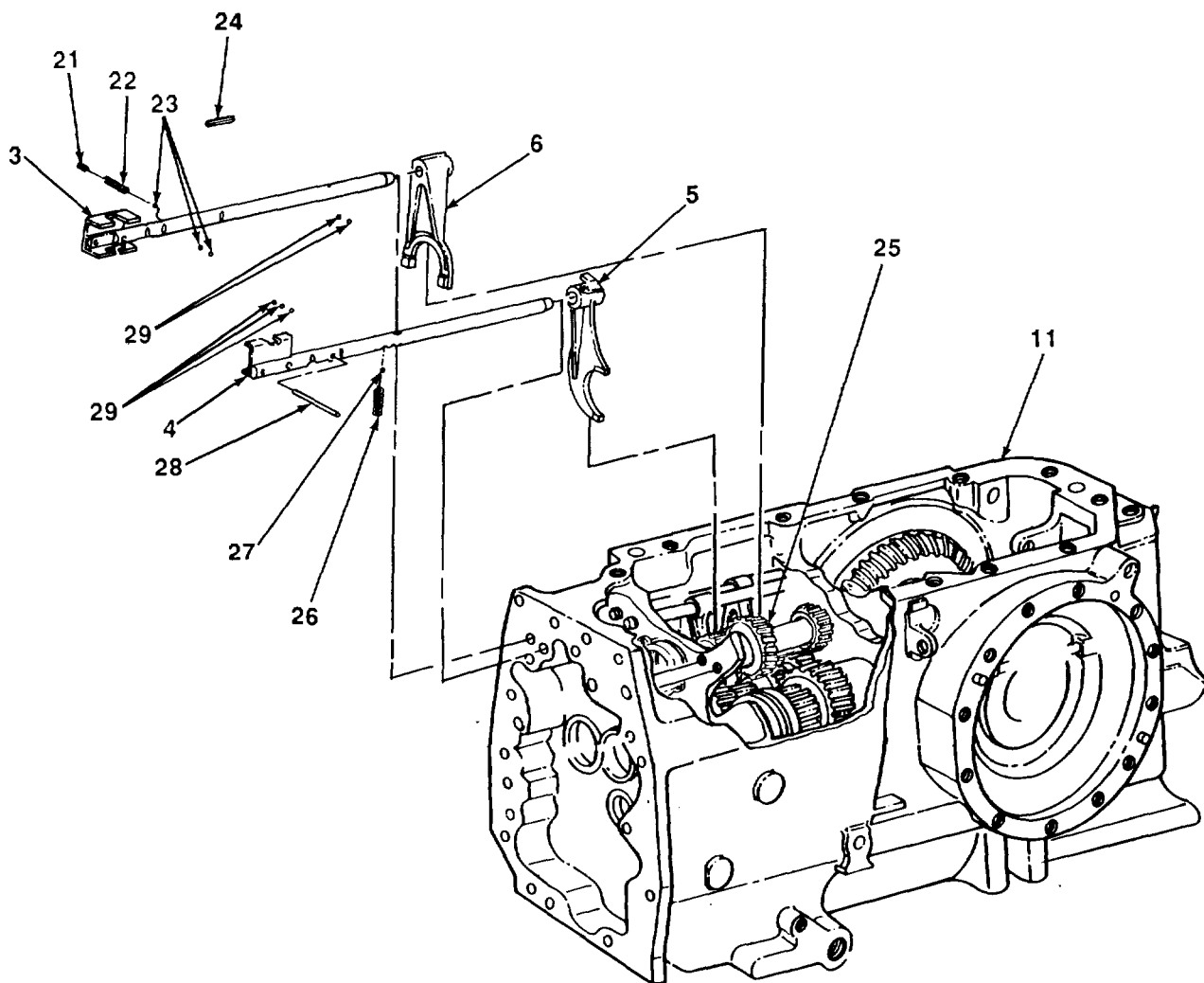

8-10. GEAR SHIFTERS AND SHIFTER SHAFTS MAINTENANCE. (Con't)

b. CLEANING AND INSPECTION

WARNING

Dry cleaning solvent, P-D-680, is toxic and flammable. Always wear protective goggles and gloves, and use only in a well-ventilated area. Avoid contact with skin, eyes, and clothes, and DO NOT breathe vapors. DO NOT use near open flame or excessive heat. The solvent's flash point is 100°F-138°F (38°C-59°C). If you become dizzy while using cleaning solvent, immediately get fresh air and medical help. If solvent contacts eyes, immediately wash your eyes and get medical aid.

1. Clean all metal parts with dry cleaning solvent. Dry thoroughly with clean, dry rags.
2. Inspect ball bearings (see TM 9-214).
3. Inspect shifter forks, shafts, remote control lever, and pin for cracks, breaks, bends, grooves, and excessive wear. Replace if defective.
4. Inspect four springs for cracks, bends, and breaks. Using spring tester, measure free length of springs. Free length must be 0.960 in. (24.384 mm).
5. Using spring tester and torque wrench, compress springs to 0.640 in. (16.256 mm) and read compression force on torque wrench. Compression force must be 13-17 lb.-ft. (18-23 N•m).
6. Inspect all other metal parts for cracks, breaks, and abnormal bends.
7. Inspect shifter forks for damaged threads.

c. REPAIR

Restore damaged shifter fork (5, 6, 7, and 10) threads using screw threading set.

d. INSTALLATION

1. Install pin (28) in transmission (11).
2. Install expansion plug (21) and spring (22) in transmission (11).
3. Tap new spring pin (24) in transmission (11) and expansion plug (21).

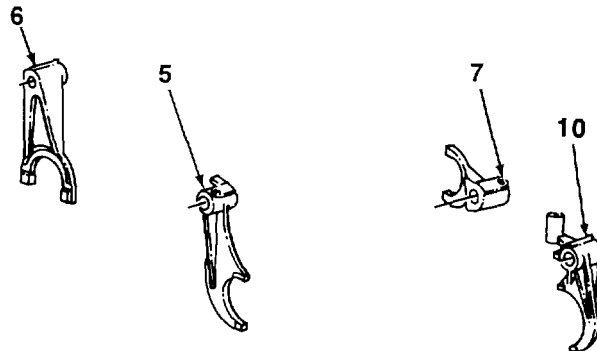

8-10. GEAR SHIFTERS AND SHIFTER SHAFTS MAINTENANCE (Con't)

4. Position shifter fork (6) in place on collar (25).
5. Position spring (26) in place in transmission (11).
6. Install indented end of transmission shifter interlock ball installer in transmission (11) just past hole for ball bearing.
7. Slide ball bearing (27) in indentation until aligned with hole in transmission (11). Push transmission shifter interlock ball installer in transmission about 2 in. (5.1 cm) and turn Y, turn.
8. While assistant supports shifter fork (5) in place on transmission (11), slide remote control lever (4) in transmission and shifter fork.
9. Remove transmission shifter interlock ball installer.
10. While assistant supports shifter fork (6) in place on transmission (11), slide shifter straight shaft (3) in transmission and shifter fork. As shaft is slid into transmission, install five ball bearings (29) and three ball bearings (23).

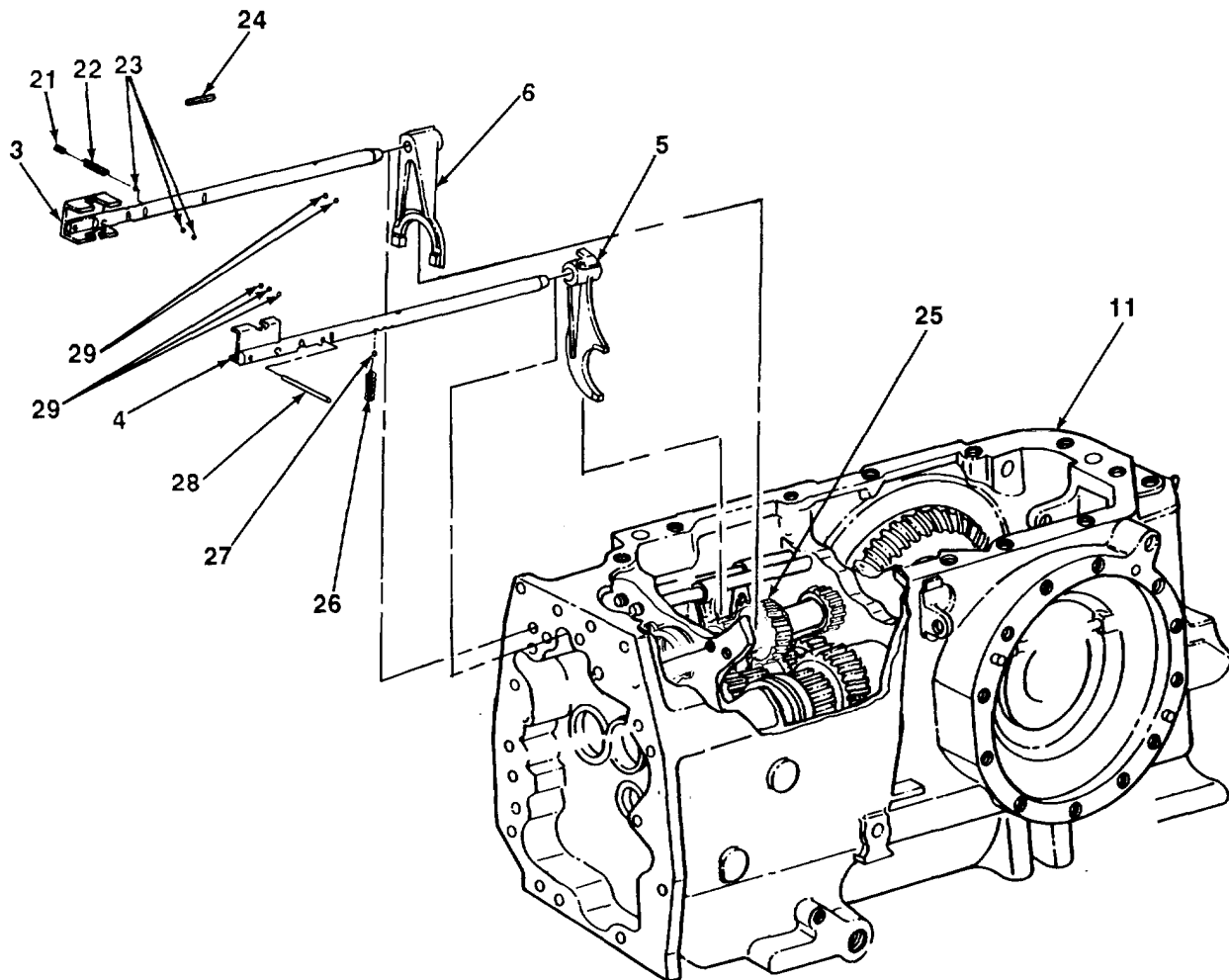

8-10. GEAR SHIFTERS AND SHIFTER SHAFTS MAINTENANCE (Con't)

11. Position shifter fork (7) in place on collar (12).
12. Install spring (1) on high range shaft (2).
13. Install spring (19) and expansion plug (18) in transmission (11).
14. Slide ball bearing (20) in indentation until alined with hole in transmission (11). Push transmission shifter interlock ball installer in transmission about 2 in. (5.1 cm) and turn $\frac{1}{4}$ turn.
15. While assistant supports shifter fork (7) in place on transmission (11), slide high range shaft (2) in transmission and shifter fork.
16. Remove transmission shifter interlock ball installer.
17. Install spring (14) and expansion plug (13) in transmission (11).
18. Tap new spring pin (16) in transmission (11) and expansion plug (13).
19. While assistant supports shifter fork (10) in place on transmission (11), slide low reverse shaft (17) in transmission and shifter fork. As shaft is slid in transmission, install three ball bearings (15).

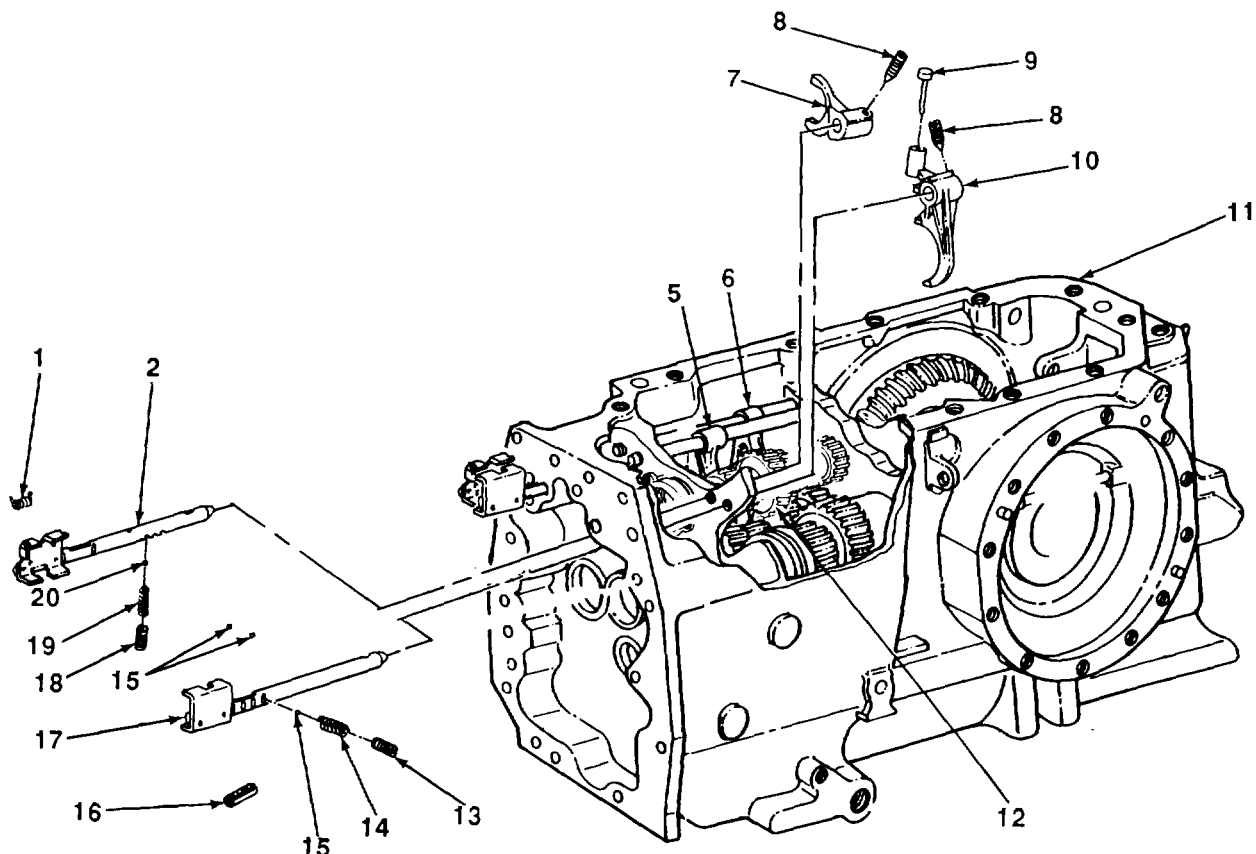

8-10. GEAR SHIFTERS AND SHIFTER SHAFTS MAINTENANCE (Con't)

20. Install four drive screws (8) in four shifter forks (5, 6, 7, and 10).

21. Install pin (9) in shifter fork (10).

FOLLOW-ON TASKS:

- Install transmission top cover (see paragraph 8-12 or 8-13).
- Install transmission (see paragraph 8-2).

8-11. REVERSER SPEED TOP COVER REPLACEMENT.

This Task Covers:

- a. Removal
- b. Installation

Initial Setup:

Equipment Conditions:

- Reverser shifter levers removed (see paragraph 8-14).
- Hydraulic brake cylinder removed (see paragraph 10-4).
- Floor panel removed (see TM 5-2420-222-20).
- Speed gear assembly (reverser) control lever linkage removed (see TM 5-2420-222-20).

Materials/Parts:

- One gasket
- Nine lockwashers

Tools/Test Equipment:

- General mechanic's tool kit
-

a. REMOVAL

1. Remove retaining ring (1), washer (2), and pin (3) from top cover (19).
2. Remove two screws (5), lockwashers (6), and control pedal (4) from top cover (19). Discard lockwashers.
3. Remove two screws (7), lockwashers (8), screw (12), lockwasher (13), two screws (14), lockwashers (15), and clamp (16). Discard lockwashers.
4. Remove two screws (9), lockwashers (10), spacer (11), top cover (19), and gasket (18). Discard lockwashers and gasket.
5. Remove adapter (17) from top cover (19).

b. INSTALLATION

1. Install adapter (17) in top cover (19).
2. Install new gasket (18) and top cover (19) with two new lockwashers (10), spacer (11), and two screws (9).
3. Install clamp (16), two screws (14), new lockwashers (15), two screws (7), new lockwashers (8), screw (12), and new lockwasher (13).
4. Install control pedal (4) on top cover (19) with two new lockwashers (6) and screws (5).
5. Install pin (3) in top cover (19) with washer (2) and retaining ring (1).

8-11. REVERSER SPEED TOP COVER REPLACEMENT (Con't).

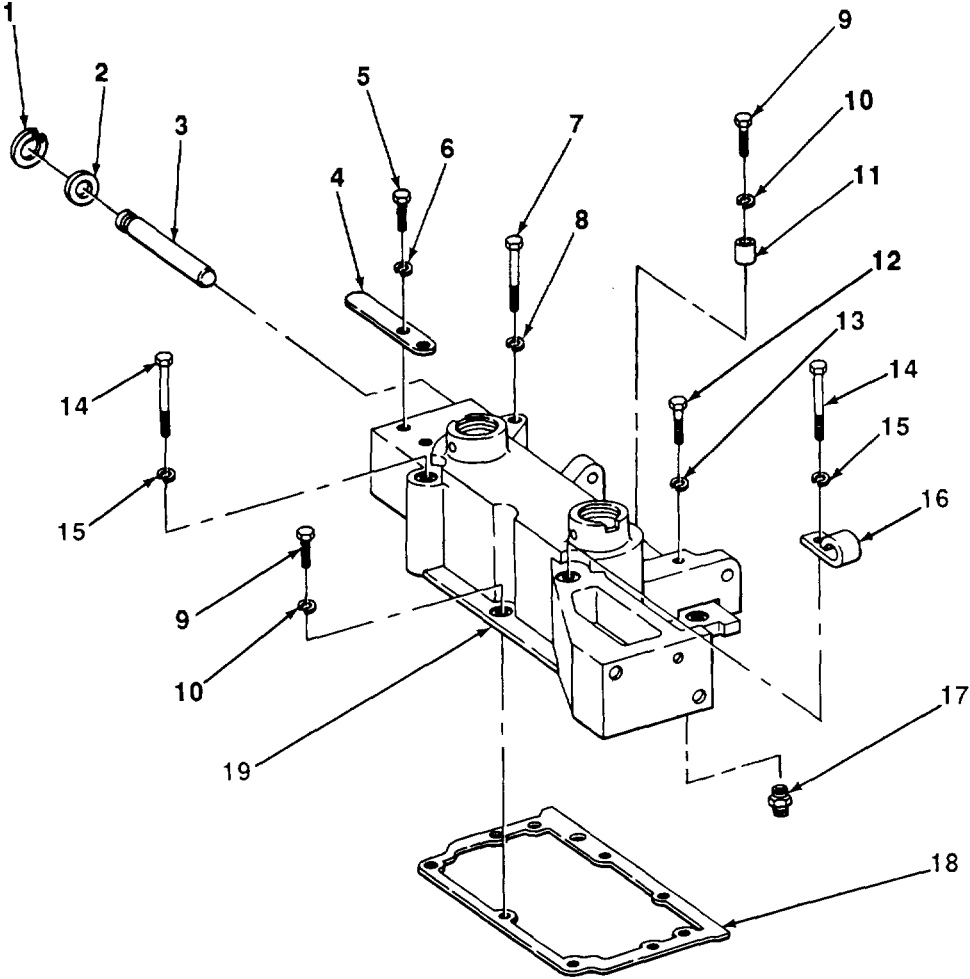

FOLLOW-ON TASKS:

- Install speed gear assembly (reverser) control lever linkage (see TM5-2420-222-20).
- Install floor panel (see TM5-2420-222-20).
- Install hydraulic brake cylinder (see paragraph 10-4).
- Install reverser shifter levers (see paragraph 8-14).

8-12. TRANSMISSION TOP COVER MAINTENANCE (SERIAL NUMBERS 235786- 235999).*This Task Covers:*

- | | | |
|----------------------------|----|-----------------|
| a. Removal | d. | Repair |
| b. Disassembly | | e. Assembly |
| c. Cleaning and Inspection | | f. Installation |

*Initial Setup:***Equipment Conditions:**

- Rear crossmember removed (see TM 5-2420-222-20).
- Transmission temperature sending unit removed (see TM 5-2420-222-20).
- Transmission liquid level gage rod removed (see TM 5-2420-222-10).

Tools/Test Equipment:

- General mechanic's tool kit
- Field automotive shop set

Materials/Parts:

- Rags (Item 28, Appendix B)
- Dry cleaning solvent (Item 31, Appendix B)
- One gasket
- Two preformed packings

Personnel Required: Two**General Safety Instructions:**

- Dry cleaning solvent is flammable and must not be used near open flame. Use only in a well-ventilated area.

a. REMOVAL

1. Remove spring (7) from pedal assembly (11) and retaining strap (6).
2. Remove ten capscrews (10) from cover (17) and transmission (15).
3. Remove capscrews (3 and 12) from cover (17) and transmission (15).
4. Remove capscrew (8) and sleeve spacer (9) from cover (17) and transmission (15).
5. With the aid of an assistant, remove cover (17) and gasket (16) from transmission (15). Discard gasket.

b. DISASSEMBLY

1. Remove filler cap (1) and preformed packing (2) from cover (17). Discard preformed packing.
2. Remove plug (13) and preformed packing (14) from cover (17). Discard preformed packing.
3. Remove capscrew (5) and retaining strap (6) from cover (17).
4. Remove tube assembly (4) from cover (17).

8-12. TRANSMISSION TOP COVER MAINTENANCE (SERIAL NUMBERS 235786- 235999). (Con't)

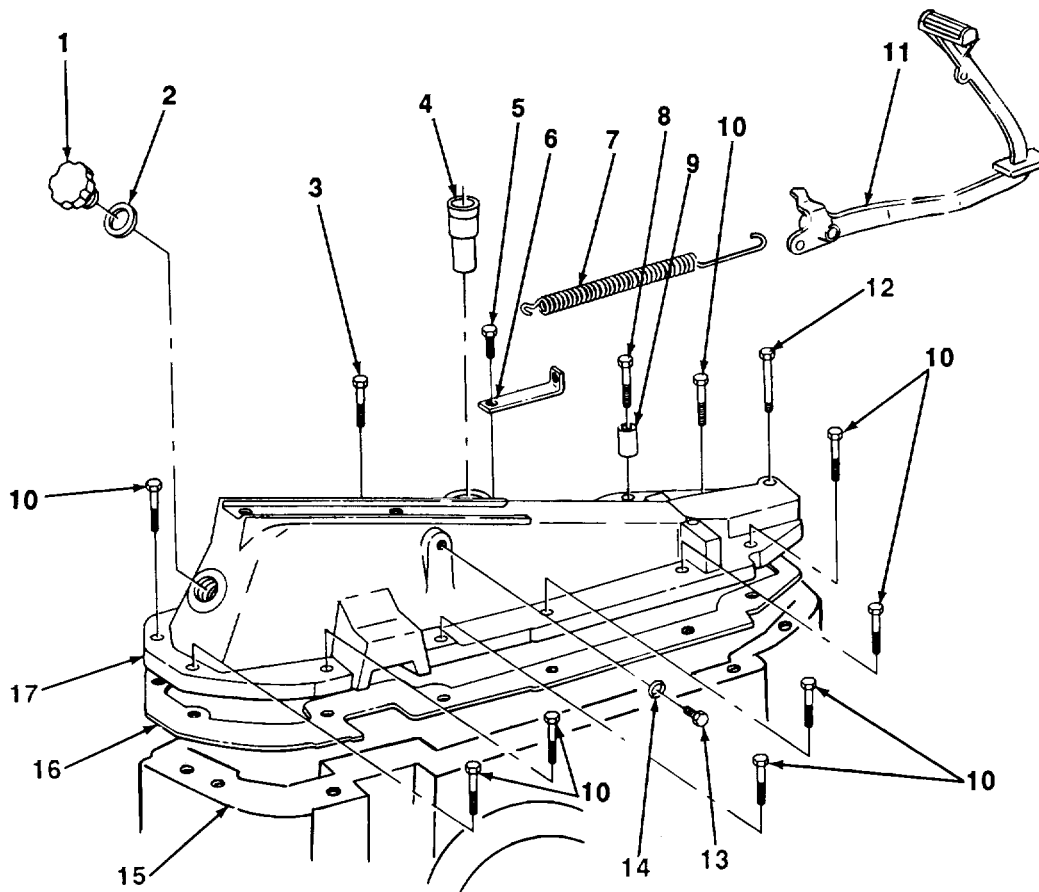

c. CLEANING AND INSPECTION

WARNING

Dry cleaning solvent, P-D-680, is toxic and flammable. Always wear protective goggles and gloves, and use only in a well-ventilated area. Avoid contact with skin, eyes, and clothes, and DO NOT breathe vapors. DO NOT use near open flame or excessive heat. The solvent's flash point is 100°F-138°F (38°C-59°C). If you become dizzy while using cleaning solvent, immediately get fresh air and medical help. If solvent contacts eyes, immediately wash your eyes and get medical aid.

1. Clean all metal parts with dry cleaning solvent. Dry thoroughly with clean, dry rags.
2. Inspect cover, retaining strap, and tube assembly for cracks, breaks, and abnormal bends. Replace if defective.
3. Inspect cover for damaged threads.

8-12. TRANSMISSION TOP COVER MAINTENANCE (SERIAL NUMBERS 235786- 235999). (Con't)

d. REPAIR

Restore damaged covey (17) threads using screw threading set.

e. ASSEMBLY

- 1. Position tube assembly (4) in place on cover (17). Tap tube assembly in cover until seated.
- 2. Position retaining strap (6) on cover (17) and secure with capscrew (5).
- 3. Install plug (13) and new preformed packing (14) in cover (17).
- 4. Install filler cap (1) and new preformed packing (2) in cover (17).

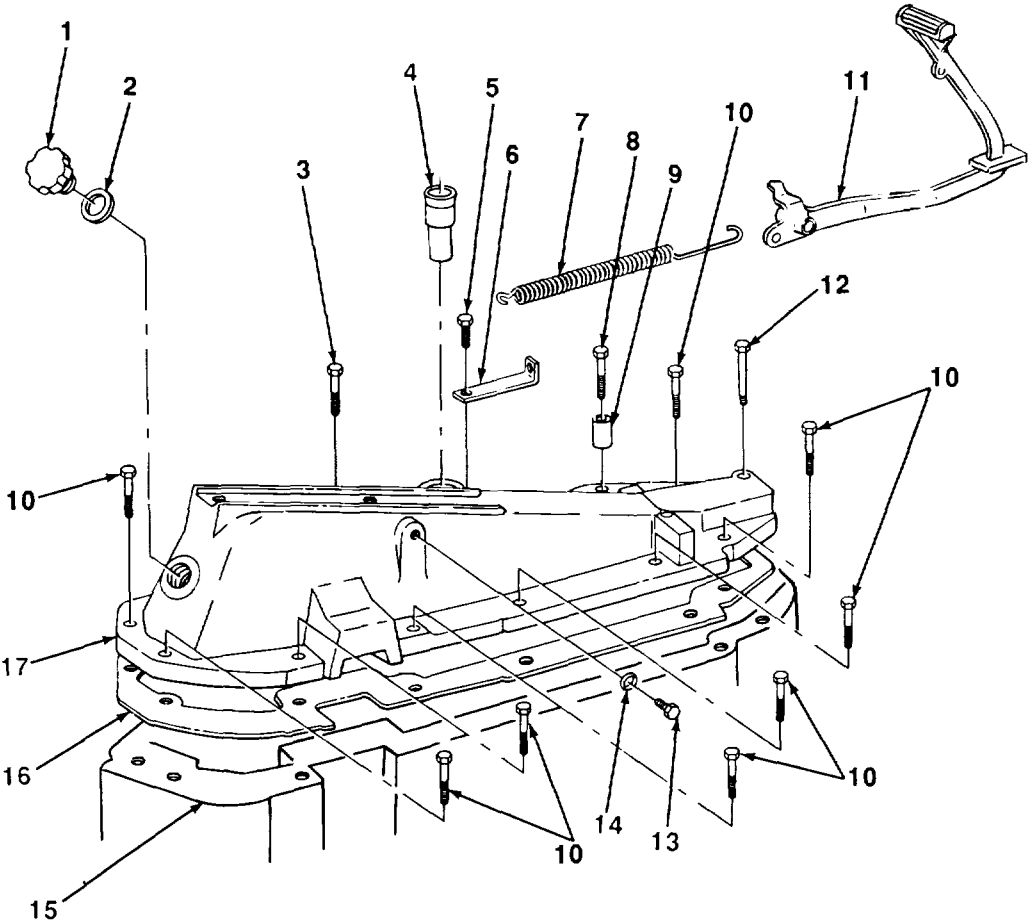

8-12. TRANSMISSION TOP COVER MAINTENANCE (SERIAL NUMBERS 235786- 235999). (Con't)

f. INSTALLATION

1. With the aid of an assistant, position cover (17) and new gasket (16) in place on transmission (15).
2. Install capscrew (8) and sleeve spacer (9) in cover (17) and transmission (15).
3. Install capscrews (3 and 12) in cover (17) and transmission (15).
4. Install ten capscrews (10) in cover (17) and transmission (15). Torque capscrews (3, 10, and 12) to 35 lb.-ft. (47 N•m).
5. Install spring (7) on retaining strap (6) and pedal assembly (11).

FOLLOW-ON TASKS:

- Install transmission liquid level gage rod (see TM5-2420-222-10).
- Install transmission temperature sending unit (see TM5-2420-222-20).
- Install rear crossmember (see TM5-2420-222-20).

8-13. TRANSMISSION TOP COVER MAINTENANCE (SERIAL NUMBERS 31995- 342573).*This Task Covers:*

- | | | |
|----------------------------|----|-----------------|
| a. Removal | d. | Repair |
| b. Disassembly | | e. Assembly |
| c. Cleaning and Inspection | | f. Installation |

*Initial Setup:***Equipment Conditions:**

- Rear crossmember removed (see TM 5-2420-222-20).
- Transmission temperature sending unit removed (see TM5-2420-222-20).
- Transmission liquid level gage rod removed (see TM5-2420-222-1 0).

Tools/Test Equipment:

- General mechanic's tool kit
- Field automotive shop set

Materials/Parts:

- Rags (Item 28, Appendix B)
- Dry cleaning solvent (Item 31, Appendix B)
- One gasket

**Personnel Required: Two
General Safety Instructions:**

- Dry cleaning solvent is flammable and must not be used near open flame. Use only in a well-ventilated area.

a. REMOVAL

1. Remove spring (2) from retaining strap (3) and pedal assembly (1).
2. Remove 13 bolts (7) from cover (8) and transmission (9).
3. Remove bolt (4), retaining strap (3), and sleeve spacer (5) from cover (8) and transmission (9).
4. Remove capscrew (13) and sleeve spacer (11) from cover (8) and transmission (9).
5. With the aid of an assistant, remove cover (8) and gasket (10) from transmission (9). Discard gasket.

b. DISASSEMBLY

1. Remove grease cap (6) from cover (8).
2. Remove tube assembly (12) from cover (8).

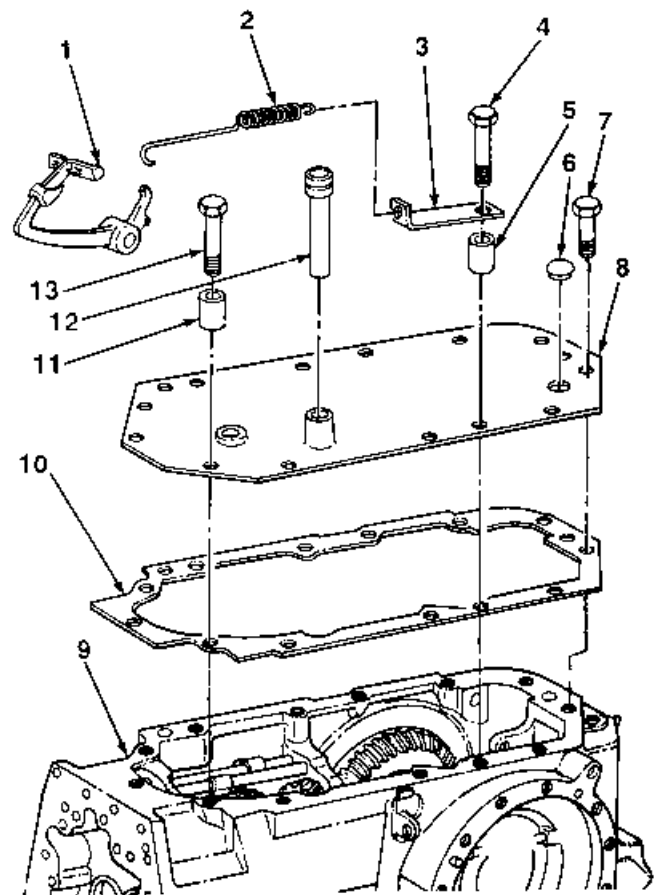

8-13. TRANSMISSION TOP COVER MAINTENANCE (SERIAL NUMBERS 319995- 342573) (Con't).

c. CLEANING AND INSPECTION**WARNING**

Dry cleaning solvent, P-D-680, is toxic and flammable. Always wear protective goggles and gloves, and use only in a well-ventilated area. Avoid contact with skin, eyes, and clothes, and DO NOT breathe vapors. DO NOT use near open flame or excessive heat. The solvent's flash point is 100°F-138°F (38°C-59°C). If you become dizzy while using cleaning solvent, immediately get fresh air and medical help. If solvent contacts eyes, immediately wash your eyes and get medical aid.

1. Clean all metal parts with dry cleaning solvent. Dry thoroughly with clean, dry rags.
2. Inspect cover, retaining strap, and tube assembly for cracks, breaks, and abnormal bends. Replace if defective.
3. Inspect cover for damaged threads.

d. REPAIR

Restore damaged cover (8) threads using screw threading set.

e. ASSEMBLY

1. Position tube assembly (12) in place on cover (8). Tap tube assembly in cover until seated.
2. Install grease cap (6) in cover (8).

f. INSTALLATION

1. With the aid of an assistant, position cover (8) and new gasket (10) in place on transmission (9).
2. Install capscrew (13) and sleeve spacer (11) in cover (8) and transmission (9).
3. Install bolt (4), retaining strap (3), and sleeve spacer (5) on cover (8) and transmission (9).
4. Install 13 bolts (7) in cover (8) and transmission (9). Torque capscrew (13), bolt (4), and bolts (7) to 35 lb.-ft. (47 N•m).
5. Install spring (2) on retaining strap (3) and pedal assembly (1).

FOLLOW-ON TASKS:

- Install transmission liquid level gage rod (see TM5-2420-222-10).
- Install transmission temperature sending unit (see TM5-2420-222-20).
- Install rear crossmember (see TM5-2420-222-20).

8-14. REVERSER SHIFTER LEVERS REPLACEMENT.

This Task Covers:

a. Removal

b. Installation

Initial Setup:

Tools/Test Equipment:

- General mechanic's tool kit
-

NOTE

Reverser range and gear shifter levers are replaced the same way.

a. REMOVAL

1. Turn knob (1) counterclockwise and remove from lever (2).
2. Pull dust boot (3) from floor (6) and remove from lever (2).
3. Remove retaining ring (4).
4. Remove lever (2) and bushing (5).

b. INSTALLATION

1. Install bushing (5) and lever (2). Secure with retaining ring (4).
2. Install dust boot (3) over lever (2) and position in floor (6).
3. Install knob (1) on lever (2).

8-14. REVERSER SHIFTER LEVERS REPLACEMENT (Con't).

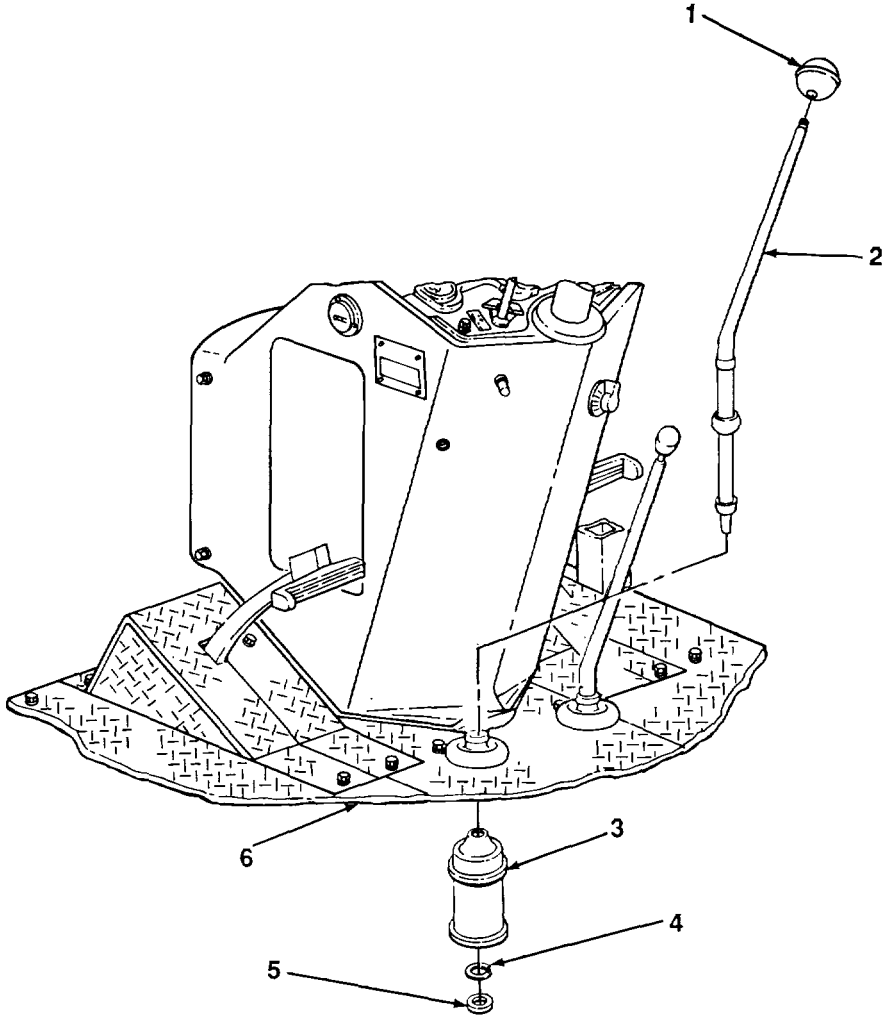

8-15. REVERSER CONTROL LEVER LINKAGE REPLACEMENT (SERIAL NUMBERS 235786-235999).*This Task Covers:*

a. Removal

b. Installation

*Initial Setup:***Equipment Conditions:**

- Speed gear assembly (reverser) control lever linkage removed (see TM 5-2420-222-20).

Materials/Parts:

- One preformed packing

Tools/Test Equipment:

- General mechanic's tool kit

a. REMOVAL

1. Remove retaining ring (5), washer (6), and pawl (7) from stud (1).
2. Remove pin (4), spring (3), and preformed packing (2). Discard preformed packing.

b. INSTALLATION

1. Install new preformed packing (2), spring (3), and pin (4).
2. Install pawl (7) on stud (1) with washer (6) and retaining ring (5).

FOLLOW-ON TASKS:

- Install speed gear assembly (reverser) control lever linkage (see TM5-2420-222-20).

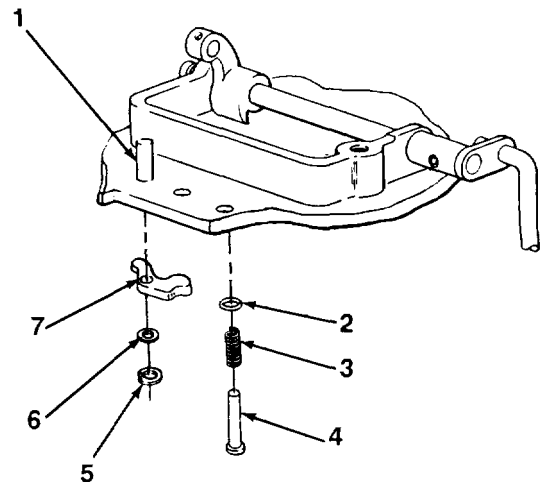

8-16. REVERSER HOUSING MAINTENANCE.

This Task Covers:

- | | | |
|----------------------------|----|-----------------|
| a. Removal | d. | Assembly |
| b. Disassembly | | e. Installation |
| c. Cleaning and Inspection | | |
-

*Initial Setup:***Equipment Conditions:**

- Platforms removed (see TM 5-2420-222-20).
- Center platform support removed (see TM5-2420-222-20).
- Battery and battery tray removed (see TM5-2420-222-20).
- Engine assembly removed (see paragraph 3-3).
- Reverser speed top cover removed (see paragraph 8-11).

Tools/Test equipment:

- General mechanic's tool kit
- Field automotive shop set

Materials/Parts:

- Rags (Item 28, Appendix B)
- Dry cleaning solvent (Item 31, Appendix B)
- One gasket
- One preformed packing

Personnel Required: Two**General Safety Instructions:**

- Dry cleaning solvent is flammable and must not be used near open flame. Use only in a well-ventilated area.
-

a. REMOVAL**WARNING**

Use extreme caution when handling heavy parts. Lifting device is required when parts weigh over 50 lb (23 kg) for a single person lift, over 100 lb (45 kg) for a two person lift, and over 150 lb (68 kg) for a three or more person lift. Keep clear of heavy parts supported only by lifting device. Failure to follow this warning may cause serious injury or death to personnel.

8-16. REVERSER HOUSING MAINTENANCE (Con't).

1. Support reverser housing (1) with a suitable lifting device.
2. Remove two screws (5), washers (4), six screws (6), and washers (7).
3. Remove screw (11) and washer (10).
4. Remove two screws (2) and washers (3). Use lifting device to separate reverser housing (1) from transmission (8).
5. Remove reverser housing (1) and gasket (9). Discard gasket.

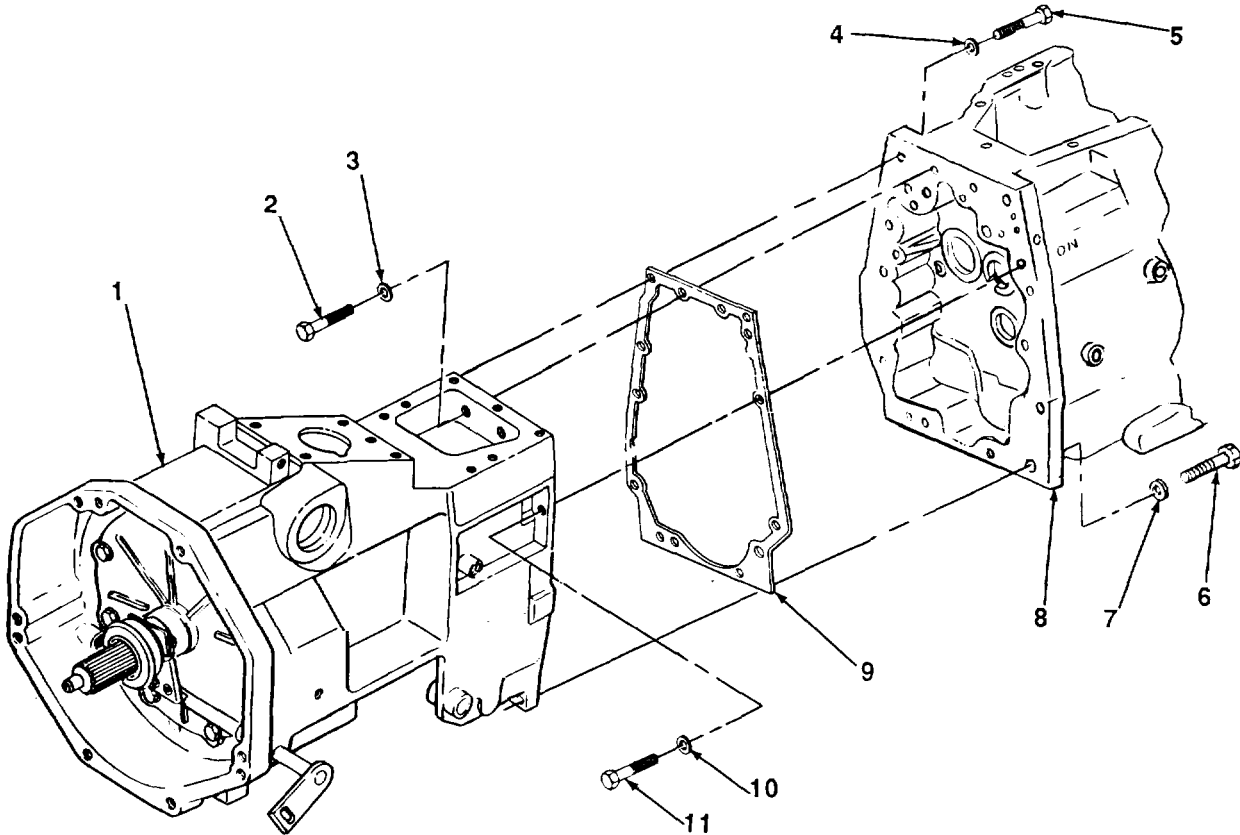

8-16. REVERSER HOUSING MAINTENANCE (Con't).

b. DISASSEMBLY

- 1. Remove clutch disk carrier or clutch support bearing carrier (see paragraph 4-4).
- 2. Remove reverser clutch drum and disk (12) as an assembly from reverser housing (1).

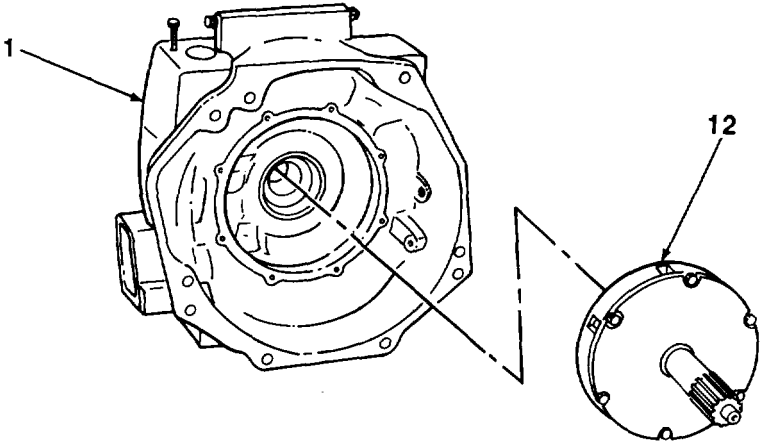

- 3. Remove two tubes (17 and 18) from transmission oil pump (13) and reverser housing (1).
- 4. Remove six screws (16) and transmission oil pump (13) from reverser brake housing (14).
- 5. Remove seven screws (19) and reverser brake housing (14) from reverser housing (1).
- 6. Remove four tubes (15) from reverser brake housing (14).

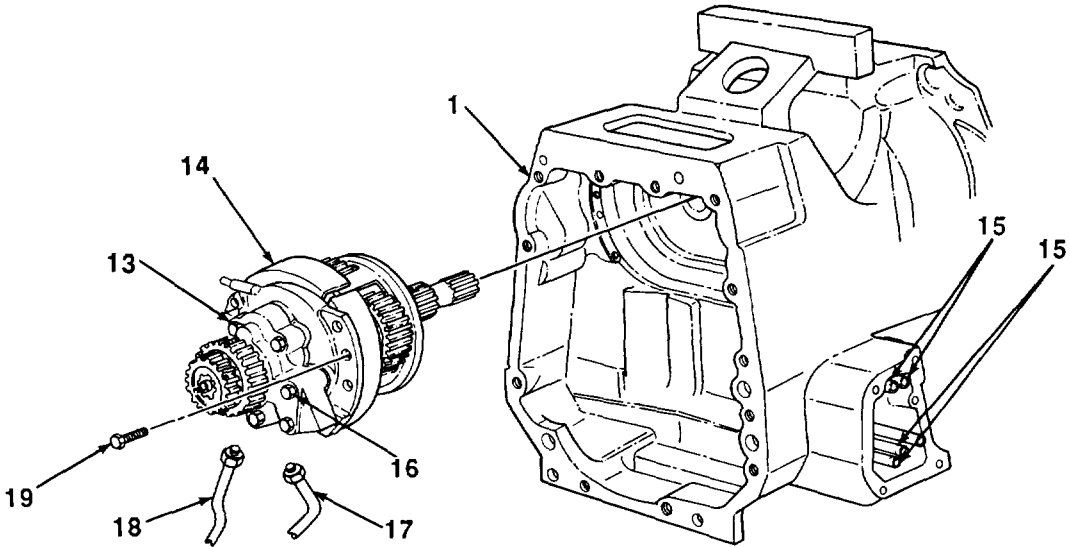

8-16. REVERSER HOUSING MAINTENANCE (Con't).

7. Remove preformed packing (20) from reverser housing (1). Discard preformed packing.

CAUTION

Remove bearing sleeve, clutch and sleeve bushings, expansion plug, and button plug in steps 8 through 11 only if damaged. Removal may damage parts.

8. Remove bearing sleeve (25) from reverser housing (1).
9. Remove clutch bushing (24) and sleeve bushing (22) from reverser housing (1).
10. Remove expansion plug (21) from reverser housing (1).
11. If equipped with button plug (23), remove button plug from reverser housing (1).

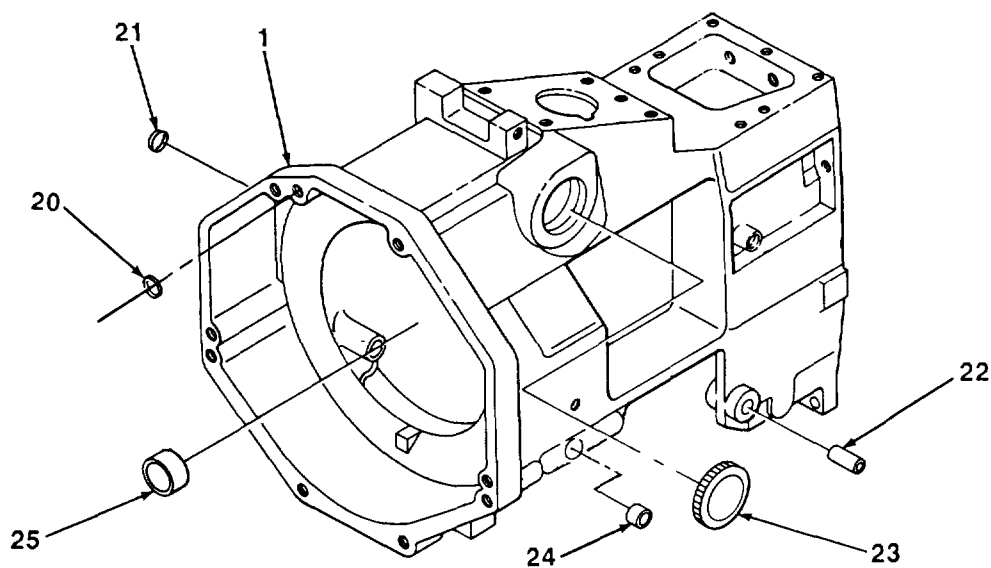
**c. CLEANING AND INSPECTION****WARNING**

Dry cleaning solvent, P-D-680, is toxic and flammable. Always wear protective goggles and gloves, and use only in a well-ventilated area. Avoid contact with skin, eyes, and clothes, and DO NOT breathe vapors. DO NOT use near open flame or excessive heat. The solvent's flash point is 100°F-138°F (38°C-59°C). If you become dizzy while using cleaning solvent, immediately get fresh air and medical help. If solvent contacts eyes, immediately wash your eyes and get medical aid.

1. Clean all metal parts with dry cleaning solvent and rags. Dry thoroughly with clean, dry rags.

8-16. REVERSER HOUSING MAINTENANCE (Con't).

2. Inspect all metal parts for cracks, breaks, and abnormal bends.
3. Inspect reverser housing for cracks, breaks, or damaged threads. Restore damaged threads using screw threading set.

d. ASSEMBLY**NOTE**

Perform steps 1 through 4 only if button plug, expansion plug, clutch and sleeve bushings, and bearing sleeve were replaced.

1. Install button plug (23) in reverser housing (1).
2. Install expansion plug (21) in reverser housing (1).
3. Install sleeve bushing (22) and clutch bushing (24) in reverser housing (1).
4. Install bearing sleeve (25) in reverser housing (1).
5. Install new preformed packing (20) in reverser housing (1).
6. Install four tubes (15) in reverser brake housing (14).
7. Install reverser brake housing (14) and tubes (15) in reverser housing (1) with seven screws (19). Torque screws to 35 lb.-ft. (47 N•m).
8. Install transmission oil pump (13) on reverser brake housing (14) with six screws (16). Torque screws to 35 lb.-ft. (47 N•m).
9. Install two tubes (17 and 18) in transmission oil pump (13) and reverser housing (1).

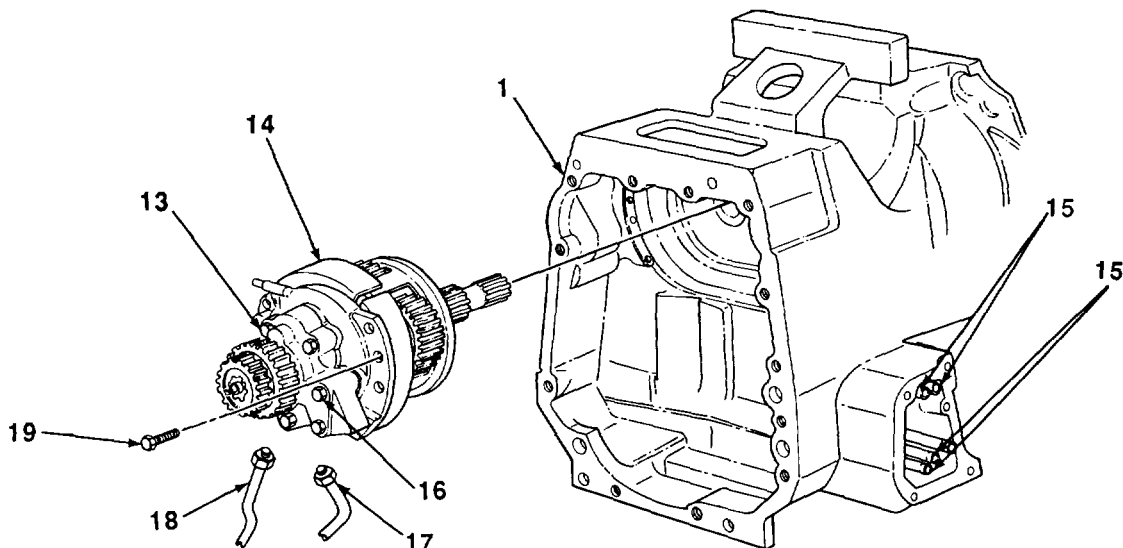

8-16. REVERSER HOUSING MAINTENANCE (Con't).

10. Install reverser clutch drum and disk (12) as an assembly in reverser housing (1).
11. Install clutch disk carrier or clutch support bearing carrier (see paragraph 4-4).

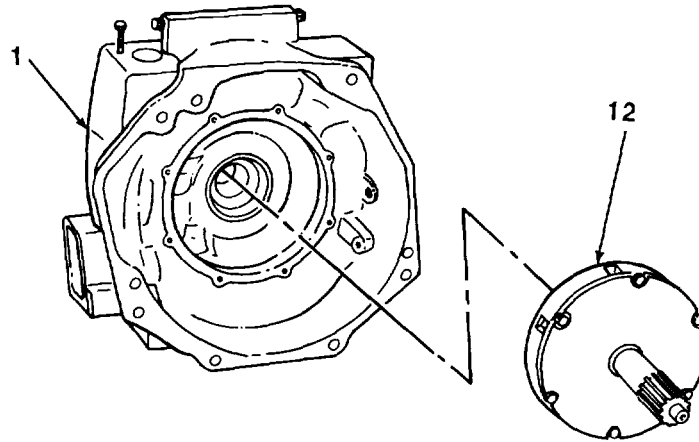
**e. INSTALLATION****WARNING**

Use extreme caution when handling heavy parts. Lifting device is required when parts weigh over 50 lb (23 kg) for a single person lift, over 100 lb (45 kg) for a two person lift, and over 150 lb (68 kg) for a three or more person lift. Keep clear of heavy parts supported only by lifting device. Failure to follow this warning may cause serious injury or death to personnel.

1. Use lifting device to align reverser housing (1) with transmission (8).
2. Install new gasket (9) on reverser housing (1).
3. Align mounting holes of reverser housing (1) with holes in transmission (8).
4. Install two screws (2) and washers (3). Do not tighten.
5. Install screw (11) and washer (10). Do not tighten.
6. Install six screws (6), washers (7), two screws (5), and washers (4).
7. Tighten screw (11) and two screws (2).
8. Remove lifting device.

8-16. REVERSER HOUSING MAINTENANCE (Con't).

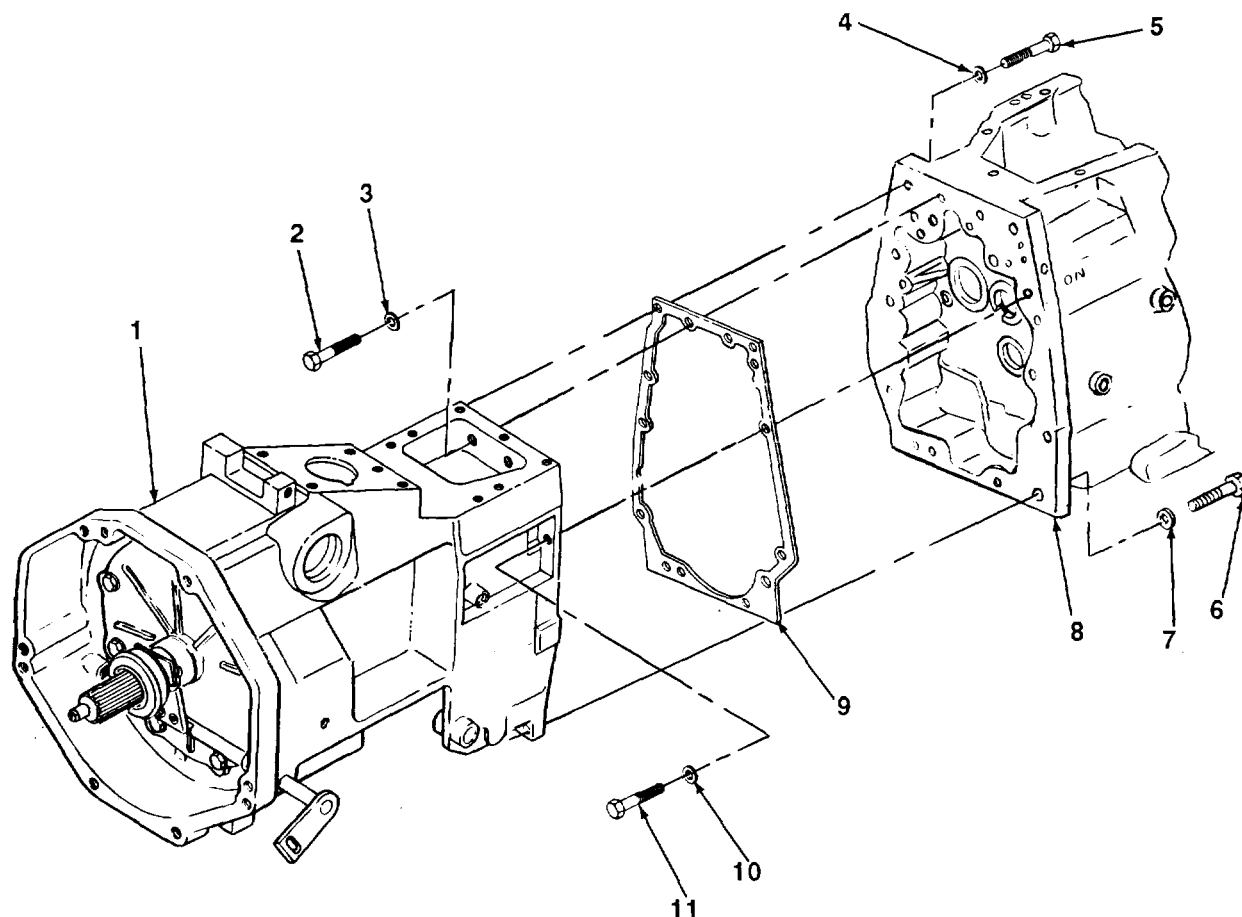

FOLLOW-ON TASKS:

- Install reverser speed top cover (see paragraph 8-11).
- Install engine assembly (see paragraph 3-3).
- Install battery tray and battery (see TM 5-2420-222-20).
- Install center platform support (see TM 5-2420-222-20).
- Install platforms (see TM 5-2420-222-20).

8-17. REVERSER BRAKE HOUSING REPAIR.

This Task Covers:

- a. Disassembly
- b. Cleaning and Inspection
- c. Assembly

Initial Setup:

Equipment Conditions:

- Reverser brake housing removed (see paragraph 8-16).

Tools/Test Equipment

- General mechanic's tool kit
- Field automotive shop set
- Modified oil filter cover

Materials/Parts:

- Grease (Item 22, Appendix B)
- Rags (Item 28, Appendix B)

- Dry cleaning solvent (Item 31, Appendix B)
- One preformed packing
- One spring pin
- Three spring washers

General Safety Instructions:

- Dry cleaning solvent is flammable and must not be used near open flame. Use only in a well-ventilated area.

a. DISASSEMBLY

1. Remove spring pin (11) from gearshaft (6). Discard spring pin.
2. Remove three screws (10), deflector (9), bearing washer (12), and hub (8) from carrier (4).
3. Remove thrust washer (7) from gearshaft (6).

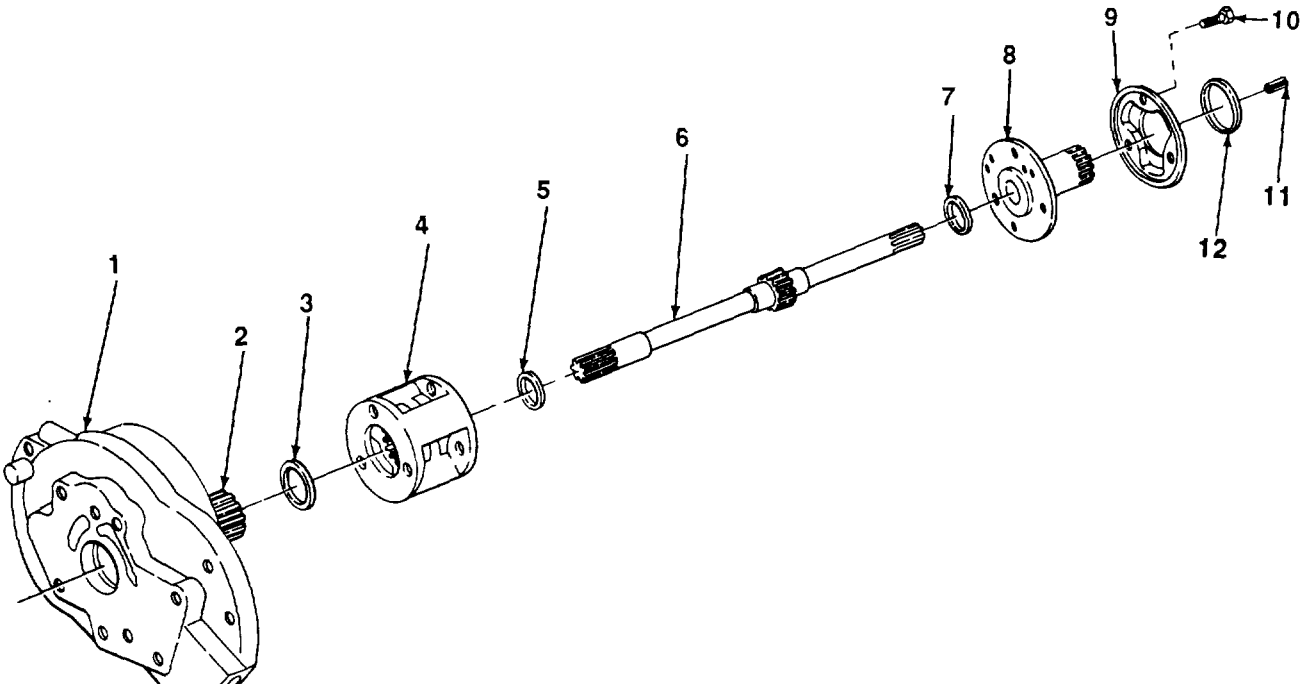

8-17. REVERSER BRAKE HOUSING REPAIR (Con't).**CAUTION**

Do not lose roller bearings that form part of planet pinions when removing gearshaft. Loss of roller bearings will damage equipment.

4. Remove gearshaft (6) from carrier (4).
5. Remove washer (5) from gearshaft (6).
6. Remove carrier (4) from spur gear (2).
7. Remove bearing washer (3) from spur gear (2) in reverser brake housing (1).

NOTE

Repeat steps 8 and 9 to remove remaining two gears.

8. To remove gear (16) from carrier (4), push shaft (18) a slight distance from carrier and remove ball bearing (13) from end of shaft.

CAUTION

Do not lose roller bearings that form part of planet pinions when removing shaft. Loss of roller bearings will damage equipment.

9. Pull shaft (18) out of carrier (4) and remove gear (16), 23 roller bearings (15), two washers (14), a spacer (17).

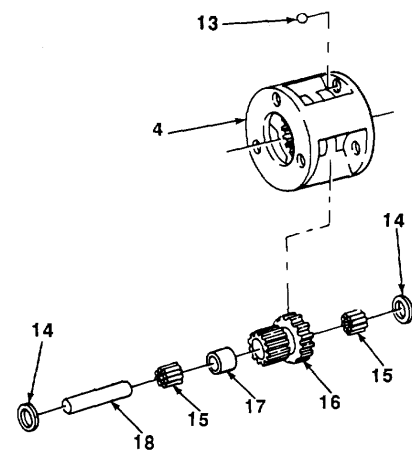

8-17. REVERSER BRAKE HOUSING REPAIR (Con't).

- 10. Remove spur gear (2) from hub (24). Remove hub from reverser brake housing (1).
- 11. Remove retaining ring (23) and disk brake (22) from reverser brake housing (1).
- 12. Remove four disk clutches (20) and four disk clutches with facing (21).
- 13. Remove bearing washer (19) from reverser brake housing (1).

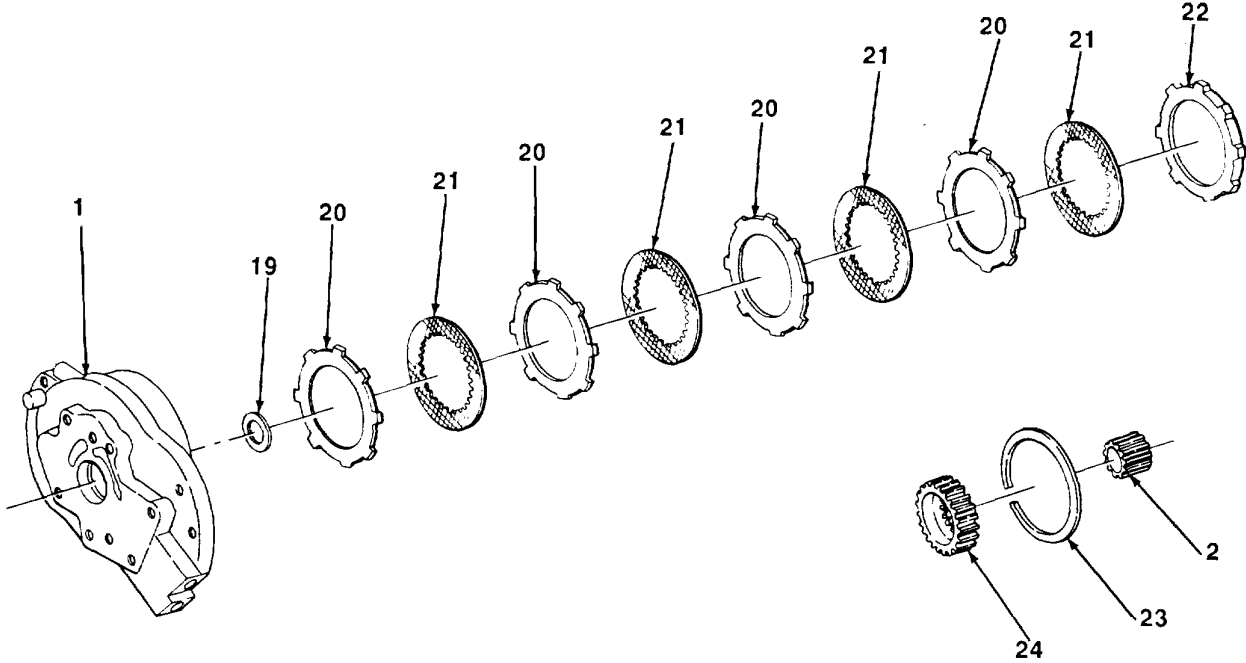

- 14. Using modified oil filter cover 925), press down on spring washers (27) to relieve pressure on piston (28).
- 15. Remove retaining ring (26) from three spring washers (27).

WARNING
Spring washers are under tension. Use care when releasing pressure on modified oil filter cover. Spring washers may spring up and cause injury to personnel.

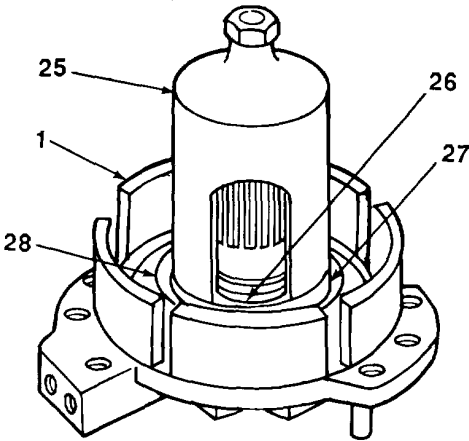

8-17. REVERSER BRAKE HOUSING REPAIR (Con't).**NOTE**

Note how spring washers are stacked to ensure proper assembly.

16. Slowly release pressure on modified oil filter cover (25) until spring washers (27) are loose. Remove modified oil filter cover.
17. Remove retaining ring (26), three spring washers (27), and piston (28) from reverser brake housing (1). Discard spring washers.
18. Remove seal ring (29) from piston (28).
19. Remove preformed packing (30) from reverser brake housing (1). Discard preformed packing.
20. If damaged, remove grooved pin (31) and pin (32) from reverser brake housing (1).

b. CLEANING AND INSPECTION**WARNING**

Dry cleaning solvent, P-D-680, is toxic and flammable. Always wear protective goggles and gloves, and use only in a well-ventilated area. Avoid contact with skin, eyes, and clothes, and DO NOT breathe vapors. DO NOT use near open flame or excessive heat. The solvent's flash point is 100°F-138°F (38 °C-59 °C). If you become dizzy while using cleaning solvent, immediately get fresh air and medical help. If solvent contacts eyes, immediately wash your eyes and get medical aid.

1. Clean all metal parts with dry cleaning solvent. Dry thoroughly with clean, dry rags.
2. Inspect thrust washers, hub, gearshaft, carrier, and gears for cracks, breaks, and missing or damaged teeth or splines. Replace if defective.
3. Inspect disk clutches with facing to ensure that grooved pattern is not worn or chipped off, or internal teeth are not damaged.
4. Inspect roller bearings (see TM 9-214).

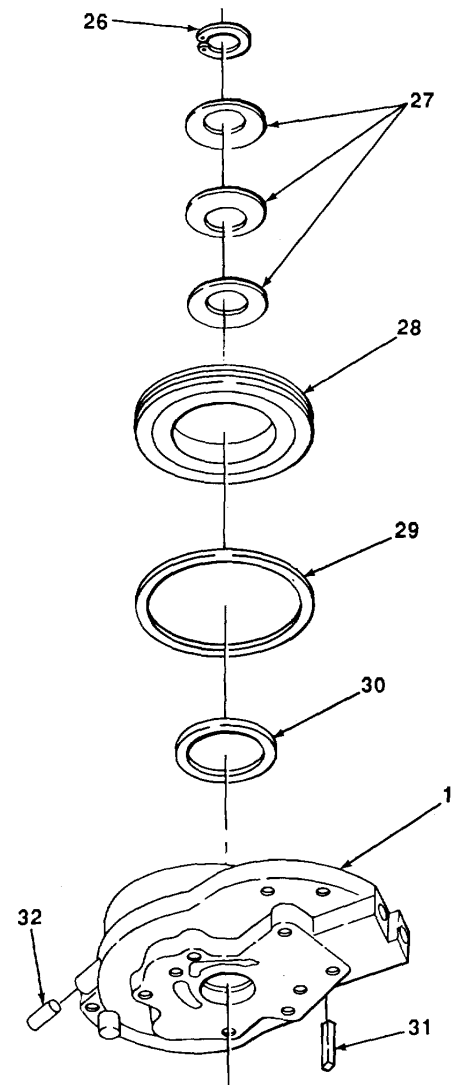

8-17. REVERSER BRAKE HOUSING REPAIR (Con't).

c. ASSEMBLY

1. If removed, install pin (32) and grooved pin (31) in reverser brake housing (1).
2. Install new preformed packing (30) in reverser brake housing (1).
3. Install seal ring (29) on piston (28).

NOTE

Install first spring washer with concave side against piston. Position second and third spring washers concave side-to-concave side and position against first spring washer.

4. Install piston (28) in reverser brake housing (1). Position three new spring washers (27) against piston, and place retaining ring (26) on top of spring washers.

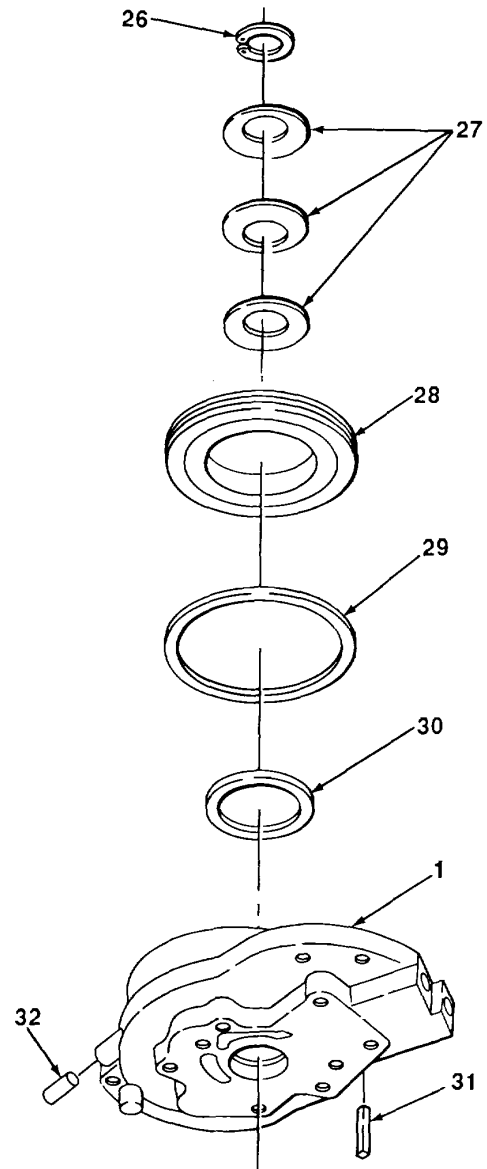

8-17. REVERSER BRAKE HOUSING REPAIR (Con't).

- 5. Using modified oil filter cover (25), press down on spring washers (27) until retaining ring (26) can be installed to secure piston (28).
- 6. Remove modified oil filter cover (25).

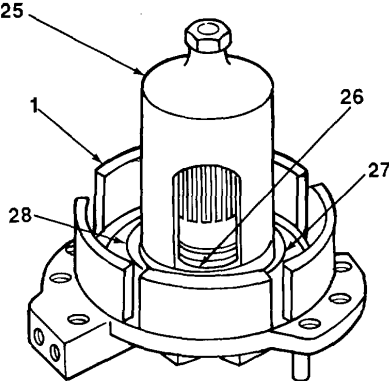

- 7. Install bearing washer (19), hub (24), and spur gear (2) in reverser brake housing (1).
- 8. Install four disk clutches (20) and four disk clutches with facing (21).
- 9. Install disk brake (22) in reverser brake housing (1) and secure with retaining ring (23).

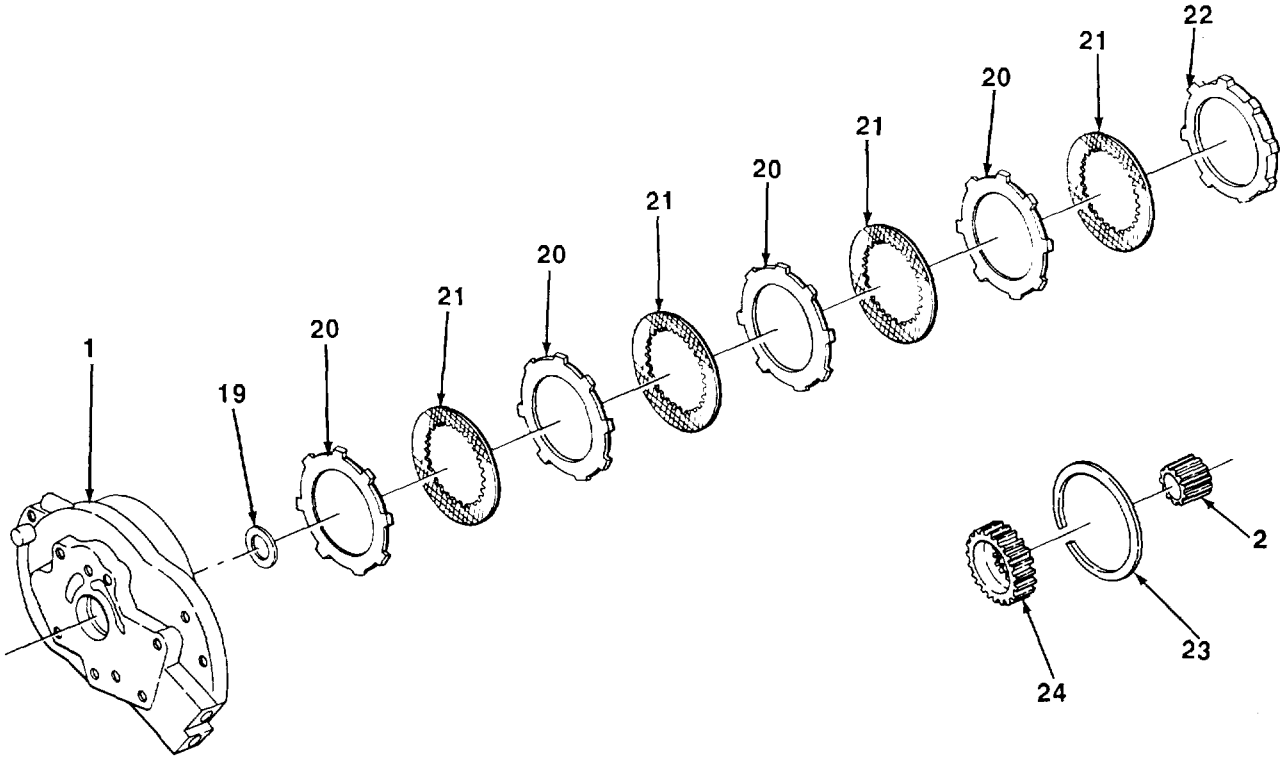

8-17. REVERSER BRAKE HOUSING REPAIR (Con't).

- 10. Install bearing washer (3) on spur gear (2) in reverser brake housing (1).
- 11. Install washer (5) on gearshaft (6) and install gearshaft in spur gear (2).
- 12. Install carrier (4) over gearshaft (6).

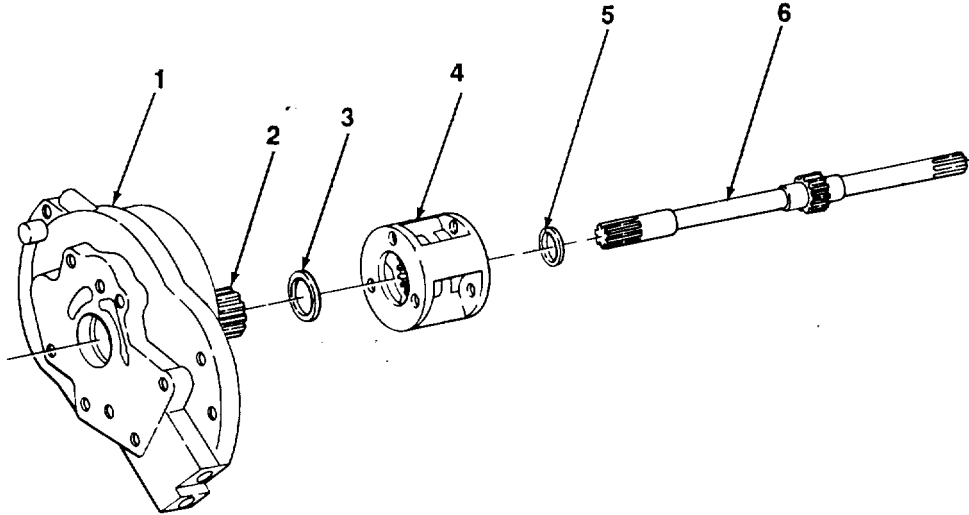

NOTE
Carrier gears are a matched set.

- 13. Apply grease to 69 roller bearings (15) and 1 on three gears (16).
- 14. Install three gears (16) in carrier (4) with large end of gears facing front of carrier.
- 15. Note numbers etched on large end of gears (16) and numbers etched on gear on gearshaft (6).
- 16. Match numbers on gears (16) and gearshaft (6). Secure gears in carrier (4) with three spacers shafts (18), six washers (14), and three bearings (13).

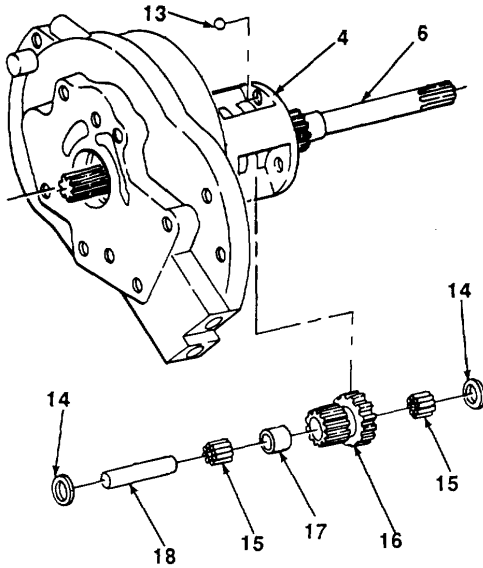

8-17. REVERSER BRAKE HOUSING REPAIR (Con't).

17. Install thrust washer (7) on gearshaft (6).
18. Position hub (8) over gearshaft (6) and on carrier (4).
19. Install deflector (9) and hub (8) on carrier (4) with three screws (10).
20. Install bearing washer (12) and new spring pin (11) through hub (8).

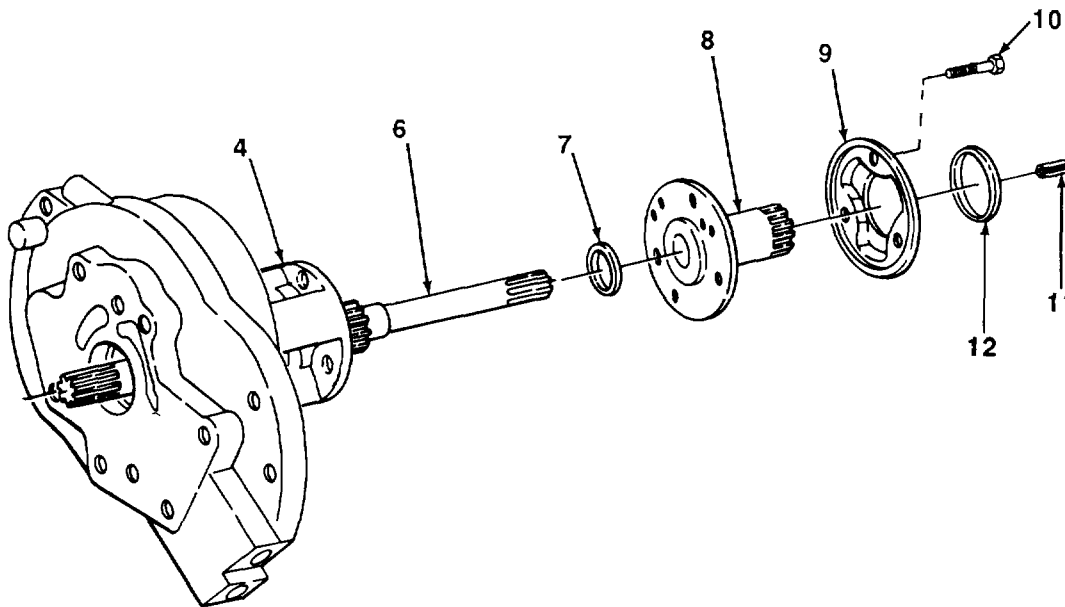
**FOLLOW-ON TASKS:**

- Install reverter brake housing (see paragraph 8-16).

8-18. REVERSER CLUTCH DRUM AND DISK REPAIR.*This Task Covers:*

- a.
- b. Cleaning and Inspection
- c. Assembly

*Initial Setup:***Equipment Conditions:**

- Reverser clutch drum and disk removed (see paragraph 8-16).

Tools/Test Equipment:

- General Safety Instructions:
- Field automotive shop set
- Modified oil filter cover

Materials/Parts:

- Rags (Item 28, Appendix B)
- Dry cleaning solvent (Item 31, Appendix B)
- Two preformed packings
- Three spring washers

General Safety Instructions:

- Dry cleaning solvent is flammable and must not be used near open flame. Use only in a well-ventilated area.

a. DISASSEMBLY

1. Remove bearing sleeve (7) and two seal rings (8) from clutch drum (6).
2. Remove six screws (1) and separate clutch drum drive shaft (2) from clutch drum (6).
3. Remove three clutch disk separator plates (3) and three clutch disks (4) from clutch drum (6).
4. Remove hub (5) from clutch drum (6).
5. Using modified oil filter cover (10), press down on spring washers (12) to relieve pressure on piston (9).
6. Remove retaining ring (11) from spring washers (12).

WARNING

Spring washers are under tension. Use care when releasing pressure on modified oil filter cover. Spring washers may spring up and cause injury to personnel.

NOTE

Note how spring washers are stacked to ensure proper assembly.

7. Slowly release pressure on modified oil filter cover (10) until spring washers (12) are loose. Remove modified oil filter cover.

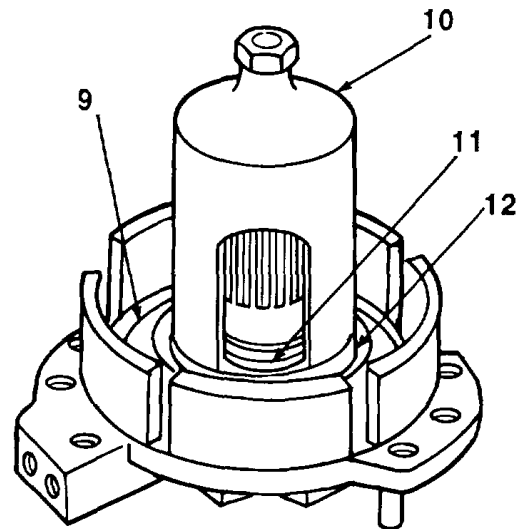

8-18. REVERSER CLUTCH DRUM AND DISK REPAIR (Con't).

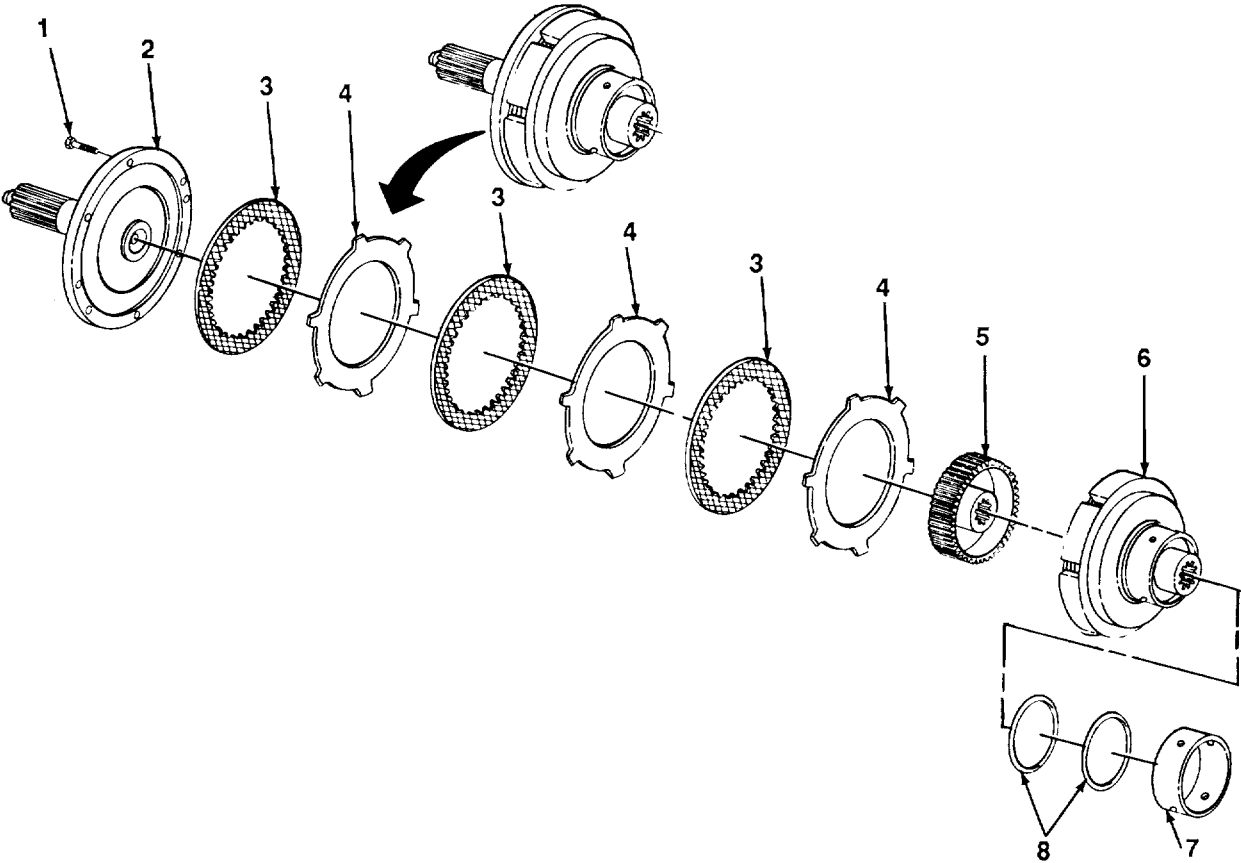

8-18. REVERSER CLUTCH DRUM AND DISK REPAIR (Con't).

8. Remove retaining ring (11), three spring washers (12), preformed packing (13), and piston (9) from clutch drum (6). Discard spring washers and preformed packing.
9. Remove preformed packing (14) from piston (9). Discard preformed packing.
10. Remove two ball bearings (16) from clutch drum (6).
11. If damaged, remove bushing (17) and two pins (15) from clutch drum (6).

b. CLEANING AND INSPECTION**WARNING**

Dry cleaning solvent, P-D-680, is toxic and flammable. Always wear protective goggles and gloves, and use only in a well-ventilated area. Avoid contact with skin, eyes, and clothes, and DO NOT breathe vapors. DO NOT use near open flame or excessive heat. The solvent's flash point is 100°F-138°F (38°C-59°C). If you become dizzy while using cleaning solvent, immediately get fresh air and medical help. If solvent contacts eyes, immediately wash your eyes and get medical aid.

1. Clean all metal parts with dry cleaning solvent. Dry thoroughly with clean, dry rags.
2. Inspect hub and splines for cracks, breaks, and missing or damaged teeth on splines. Replace if defective.
3. Inspect clutch disks to ensure that grooved pattern is not worn or chipped off, or internal teeth are not damaged.

c. ASSEMBLY

1. If removed, install bushing (17) and two pins (15) in clutch drum (6).
2. Install two ball bearings (16) in clutch drum (6).
3. Install new preformed packing (14) on piston (9).
4. Install new preformed packing (13) in clutch drum (6).

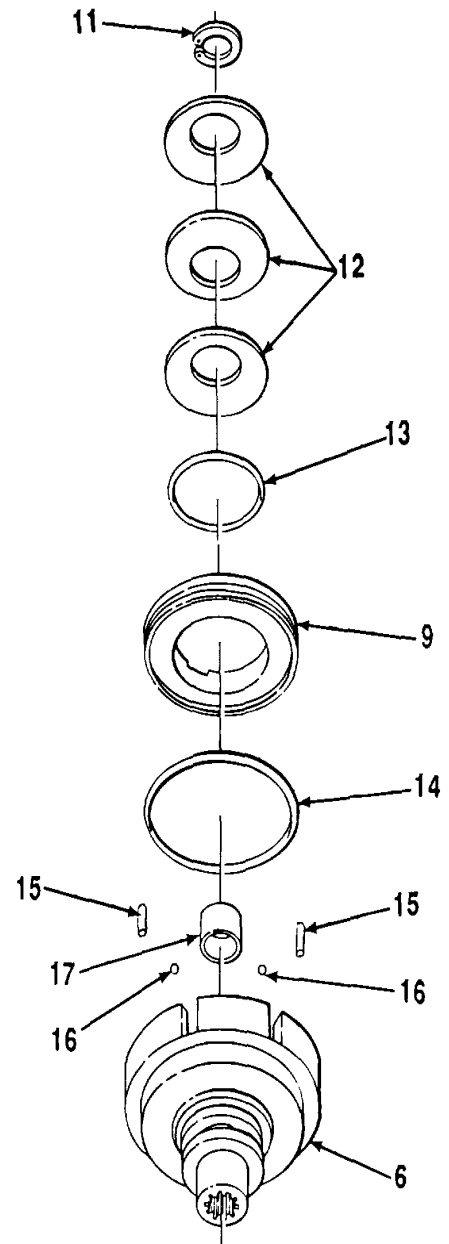

TA701414

8-18. REVERSER CLUTCH DRUM AND DISK REPAIR (Con't).**NOTE**

Install first spring washer with concave side against piston. Position second and third spring washers concave side-to-concave side and position against first spring washer.

5. Install piston (9) in clutch drum (6). Position three new spring washers (12) against piston and place retaining ring (11) on spring washers.
6. Using modified oil filter cover (10), press down on spring washers (12) until retaining ring (11) can be installed to secure piston (9).
7. Remove modified oil filter cover (10).

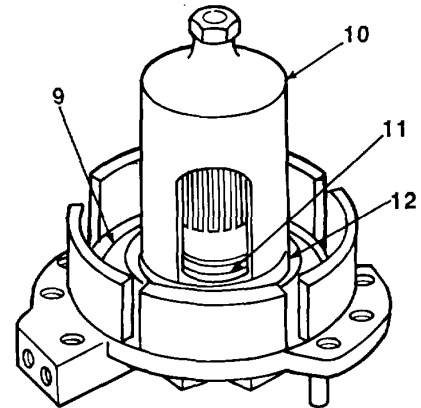

8-18. REVERSER CLUTCH DRUM AND DISK REPAIR (Con't).

8. Install hub (5) in clutch drum (6).
9. Install three clutch disk separator plates (3) and three clutch disks (4) in clutch drum (6).
10. Aline clutch drum drive shaft (2) with clutch drum (6) and install six screws (1).
11. Install two seal rings (8) and bearing sleeve (7) on clutch drum (6).

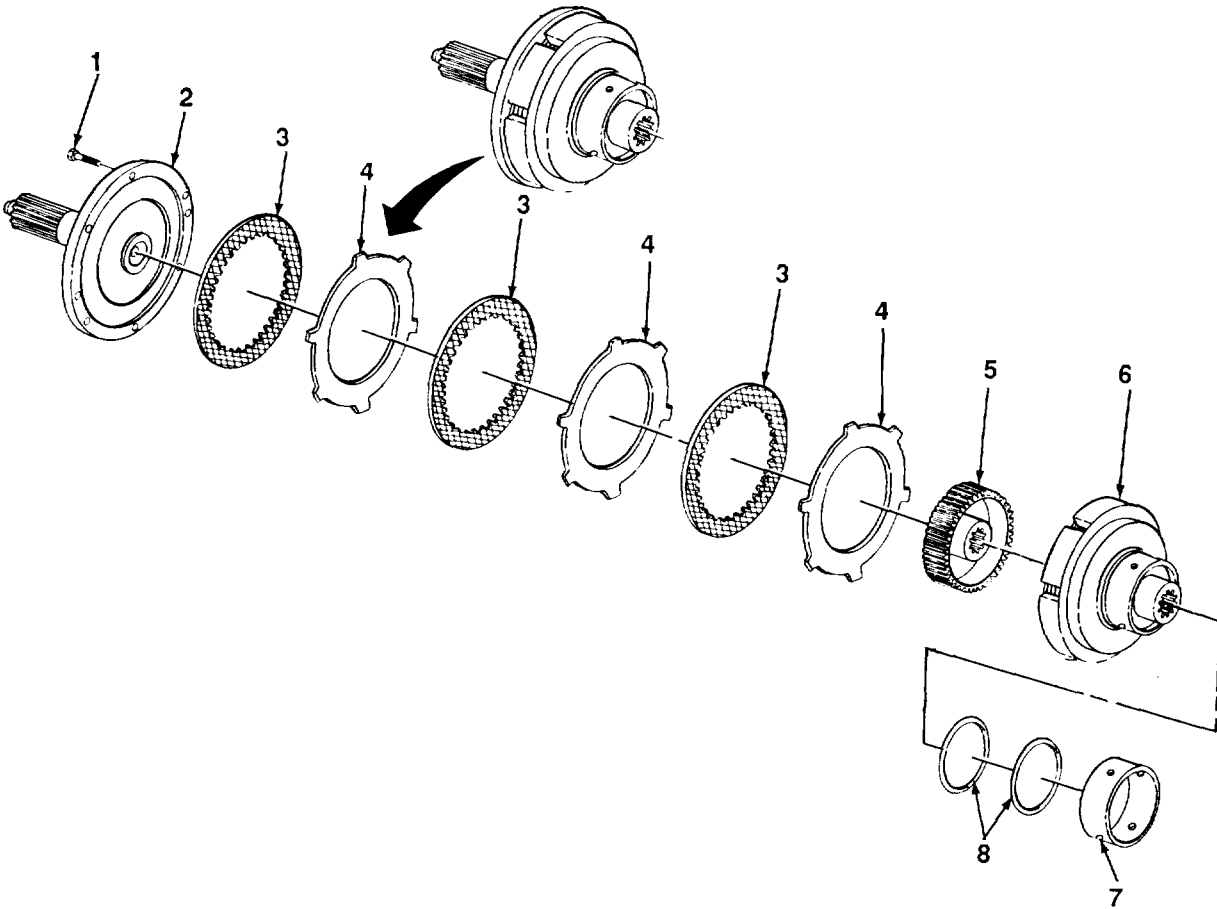
**FOLLOW-ON-TASKS:**

- Install reverser clutch drum and disk (see paragraph 8-16).

8-19. TRANSMISSION OIL PUMP MAINTENANCE.*This Task Covers:*

- | | |
|----------------------------|-----------------|
| a. Removal | d. Assembly |
| b. Disassembly | e. Installation |
| c. Cleaning and Inspection | |

*Initial Setup:***Equipment Conditions:**

- Clutch disk carrier or clutch support bearing carrier removed (see paragraph 4-4).
- Reverser oil lines removed (see paragraph 8-21).

Tools/Test Equipment:

- General mechanic's tool kit
- Field automotive shop set.

References:

- TM 9-214

Materials/Parts:

- Rags (Item 28, Appendix B)
- Dry cleaning solvent (Item 31, Appendix B)

General Safety Instructions:

- Dry cleaning solvent is flammable and must not be used near open flame. Use only in a well-ventilated area.

a. REMOVAL

Remove screw (2), five screws (8), and transmission oil pump (3) from reverser brake housing (6).

b. DISASSEMBLY

1. Remove gear (5), gear (7), and powershaft drive shaft (1) from transmission oil pump (3).
2. Remove bearing (9) from transmission oil pump (3).
3. If damaged, remove pin (4) from transmission oil pump (3).

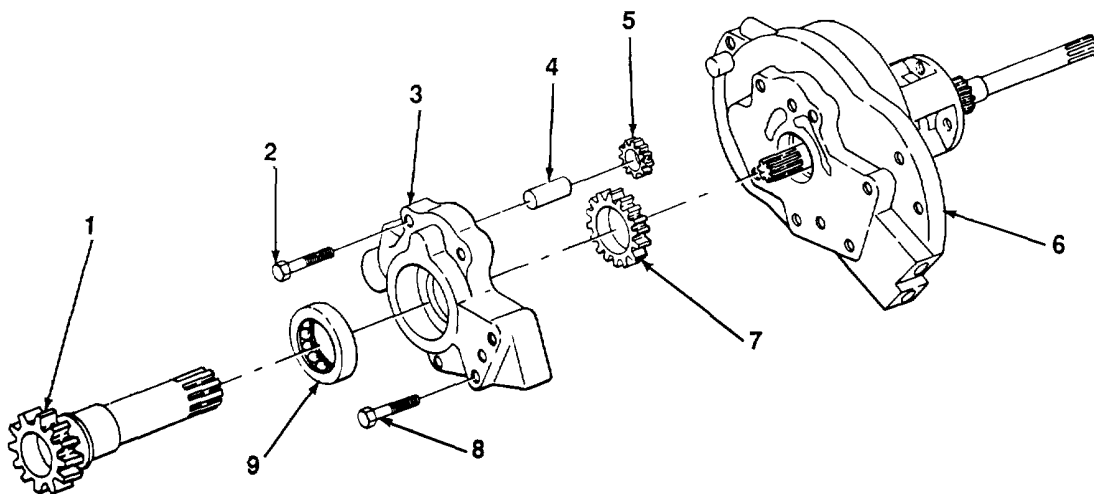

8-19. TRANSMISSION OIL PUMP MAINTENANCE (Con't).

c. CLEANING AND INSPECTION
WARNING

Dry cleaning solvent, P-D-680, is toxic and flammable. Always wear protective goggles and gloves, and use only in a well-ventilated area. Avoid contact with skin, eyes, and clothes, and **DO NOT** breathe vapors. **DO NOT** use near open flame or excessive heat. The solvent's flash point is 100°F-138°F (38°C-59°C). If you become dizzy while using cleaning solvent, immediately get fresh air and medical help. If solvent contacts eyes, immediately wash your eyes and get medical aid.

1. Clean transmission oil pump, gears, and powershaft drive shaft with dry cleaning solvent and rags. Dry thoroughly with clean, dry rags.
2. Inspect transmission oil pump, gears, and powershaft drive shaft for cracks, breaks, bends, or damaged gear teeth.
3. Inspect bearing (see TM 9-214).

d. ASSEMBLY

1. If removed, install pin (4) in transmission oil pump (3).
2. Install bearing (9) in transmission oil pump (3).

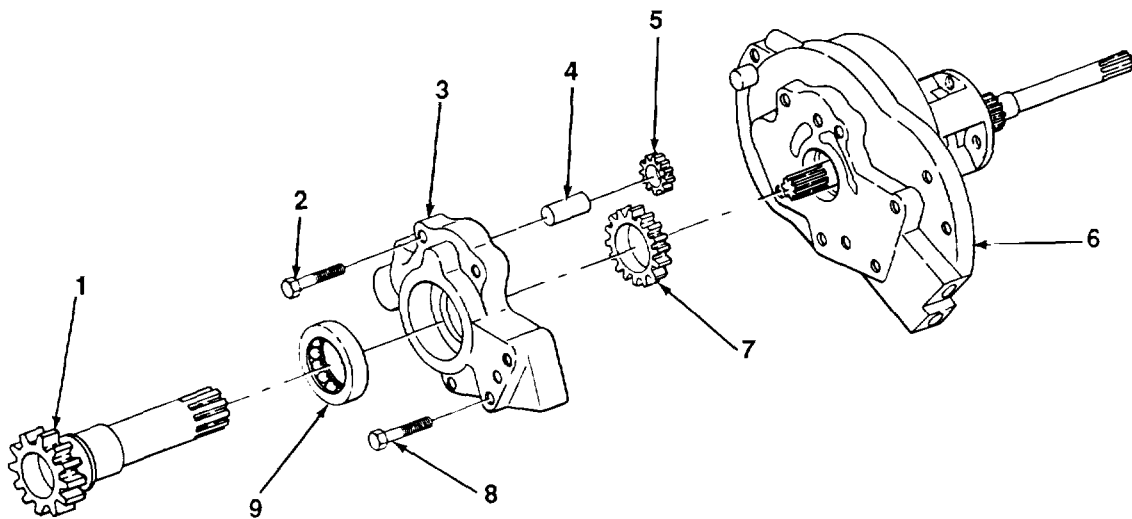

8-19. TRANSMISSION OIL PUMP MAINTENANCE (Con't).

NOTE

Gears must be replaced as a matched set.

3. Install powershaft drive shaft (1), gear (7), and gear (5) in transmission oil pump (3).

e. INSTALLATION

Position transmission oil pump (3) on reverser brake housing (6) and install five screws (8) and screw (2). Torque screws to 23 lb.-ft. (31 N•m).

FOLLOW-ON TASKS:

- Install reverser oil lines (see paragraph 8-21).
- Install clutch disk carrier or clutch support bearing carrier (see paragraph 4-4).

8-20. REVERSER CLUTCH CONTROL VALVE ASSEMBLY MAINTENANCE.

This Task Covers.

- | | |
|----------------------------|-----------------|
| a. Removal | d. Assembly |
| b. Disassembly | e. Installation |
| c. Cleaning and Inspection | |
-

Initial Setup:

Equipment Conditions

- Oil lines disconnected (see TM 5-2420-222-20).

Tools/Test Equipment:

- General mechanic's tool kit
- Field automotive shop set
- Steam cleaner

Materials/Parts:

- Rags (Item 28, Appendix B)
- Dry cleaning solvent (Item 31, Appendix B)
- Marker tags (Item 32, Appendix B)
- Three spring pins
- Four lockwashers
 - Six gaskets
- Eight preformed packings

General Safety Instructions:

- Dry cleaning solvent is flammable and must not be used near open flame. Use only in a well-ventilated area.
 - Compressed air used for cleaning purposes should never exceed 30 psi (207 kPa).
 - Avoid contact with live steam.
-

a. REMOVAL

1. Disconnect tube assembly (4) from elbow (7) and adapter (3).
2. Remove adapter (3) and preformed packing (2). Discard preformed packing.
3. Remove elbow (7) and preformed packing (8) from head (9). Discard preformed packing.
4. Remove two screws (5), washers (6), head (9), and gasket (10) from valve body (1). Discard gasket.

8-20. REVERSER CLUTCH CONTROL VALVE ASSEMBLY MAINTENANCE (Con't).

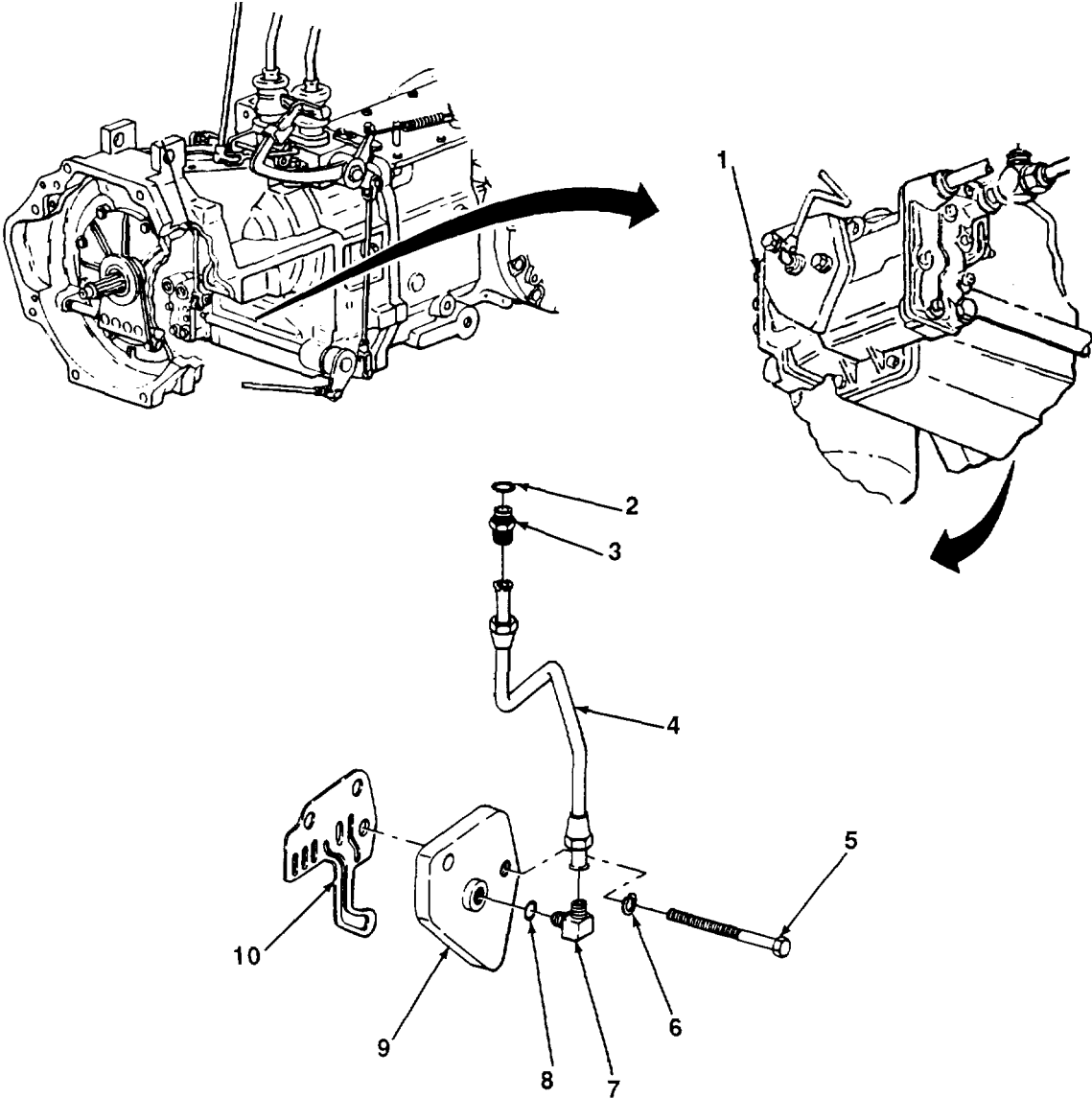

8-20. REVERSER CLUTCH CONTROL VALVE ASSEMBLY MAINTENANCE (Con't).

5. Remove spring pins (11 and 12) from shaft (14). Discard spring pins.
6. Remove lever (13) from shaft (14). Remove shaft.

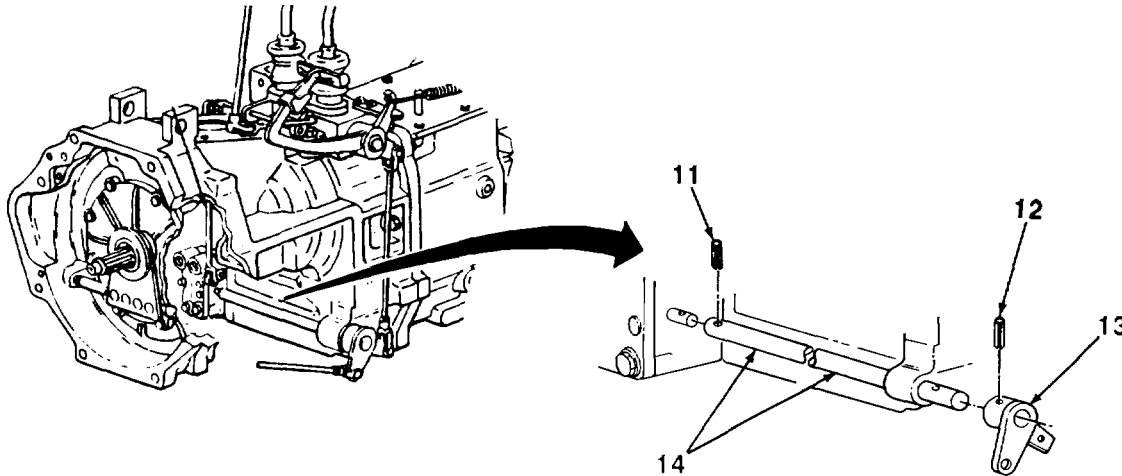

7. Remove screw (19) and lockwasher (18). Discard lockwasher.
8. remove two screws (20), lockwashers (21), valve body (1), gasket (17), retaining plate (16), and gasket (15) from reverser housing. Discard lockwashers and gaskets.

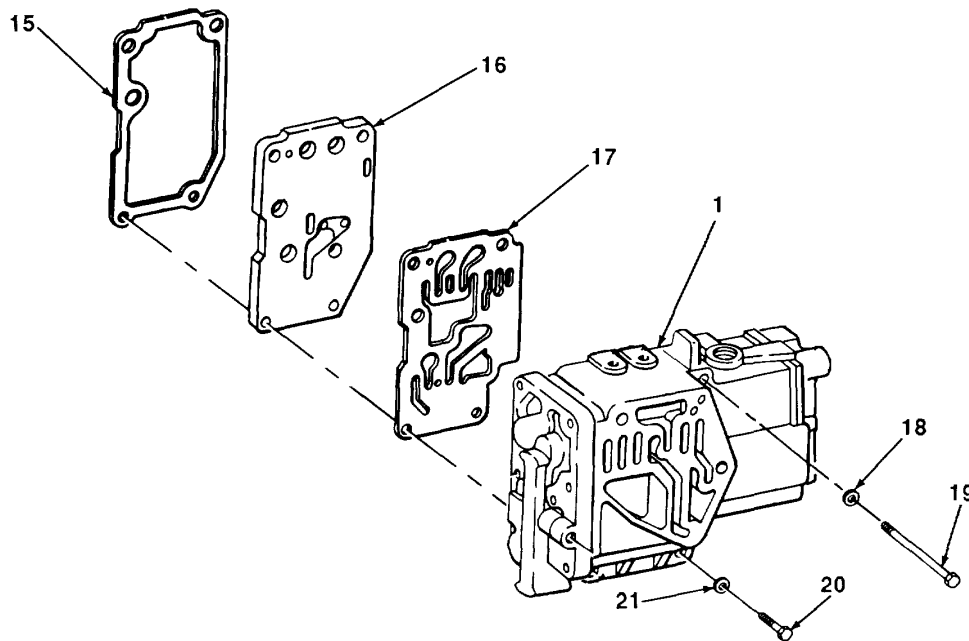

8-20. REVERSER CLUTCH CONTROL VALVE ASSEMBLY MAINTENANCE (Con't).**b. DISASSEMBLY****CAUTION**

Pump cover is spring loaded. Loosen cover screws evenly, and tag valves and springs before removing.

1. Hold pump cover (24), and remove six screws (22) and washers (23).
2. Carefully remove pump cover (24), gasket (25), piston (26), and spring (27) from valve body (1). Discard gasket.

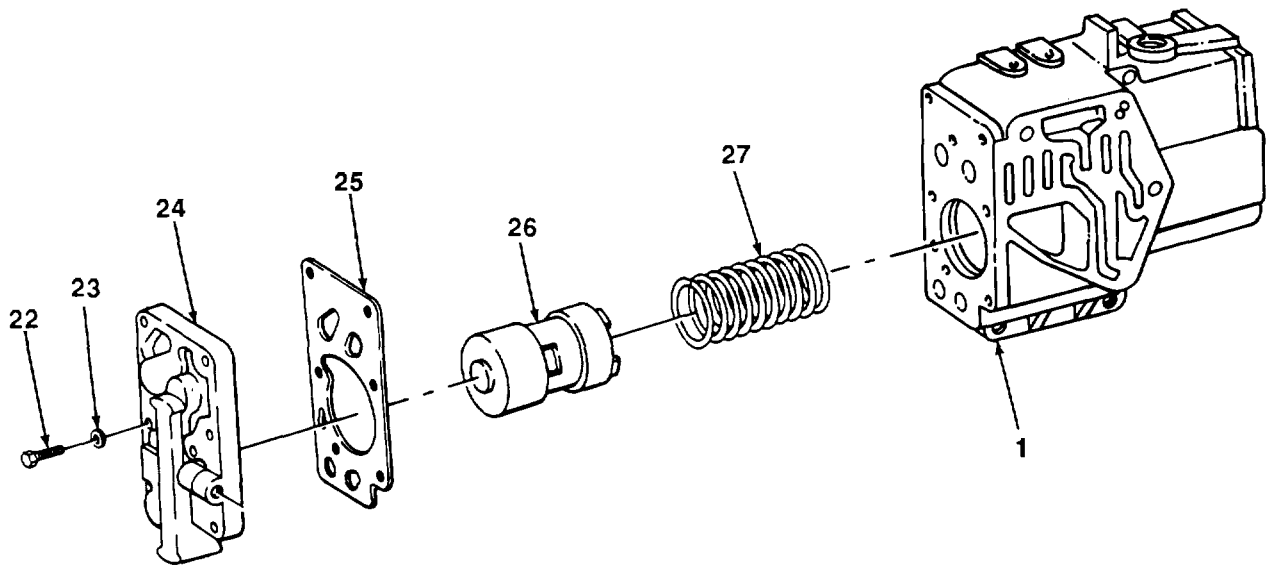

8-20. REVERSER CLUTCH CONTROL VALVE ASSEMBLY MAINTENANCE (Con't).

- 3. Remove spring (36), clutch control valve (35), spring (38), and relief valve (37) from valve body (1).
- 4. Remove pressure valve (40), spring (33), and pin (34) from valve body (1).
- 5. If damaged, remove spring pin (39) from pressure valve (40).
- 6. Remove retaining ring (28) and directional slide (29).
- 7. Remove two retaining rings (30 and 32) and remove pin (31) from directional slide (29).

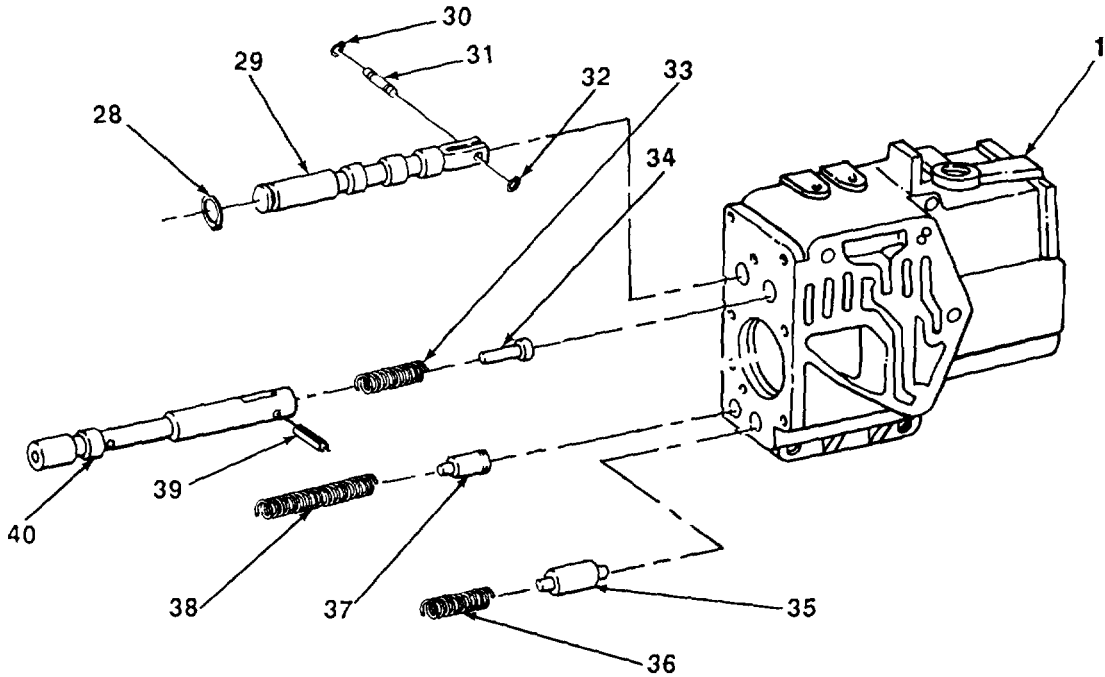

- 8. Remove screw (44) and preformed packing (43) from pump cover (24). Discard preformed packing.
- 9. Remove drain plug (41) and preformed packing (42) from pump cover (24). Discard preformed packing.

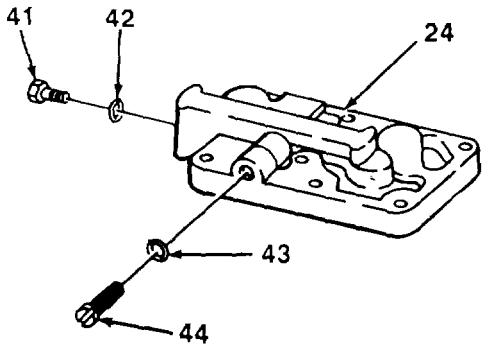

8-20. REVERSER CLUTCH CONTROL VALVE ASSEMBLY MAINTENANCE (Con't).

10. Remove five screws (55), washers (54), control cover (53), gasket (52), retaining plate (51), and gasket (50) from valve body (1). Discard gaskets.
11. Remove screw (47), lockwasher (48), and retaining plate (49) from control cover (53). Discard lockwasher.
12. Remove plug (56) and preformed packing (57) from control cover (53). Discard preformed packing.
13. Remove three washers (shims) (58), spring (59), and pressure regulating control valve (60) from valve body (1).
14. Remove two drain plugs (45) and preformed packings (46) from valve body (1). Discard preformed packings.

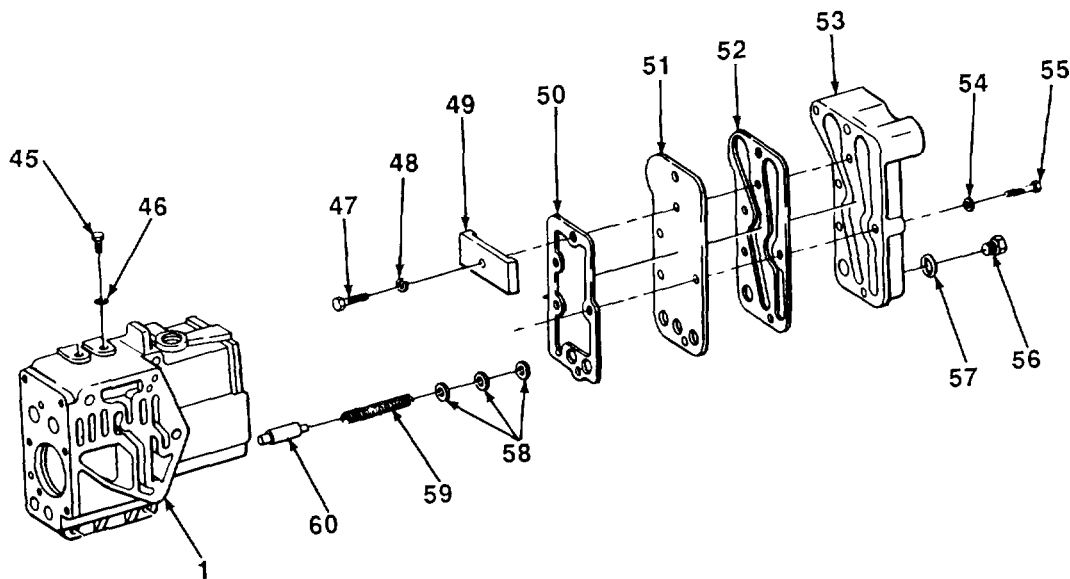

8-20. REVERSER CLUTCH CONTROL

15. Remove vent plug (62), preformed packing (63), spring (64), and ball bearing (65) from valve body (1). Discard preformed packing.
16. If damaged, remove two seals (61).
17. Remove spring pin (67) and remote levers (66 and 68) from valve body (1). Discard spring pin.

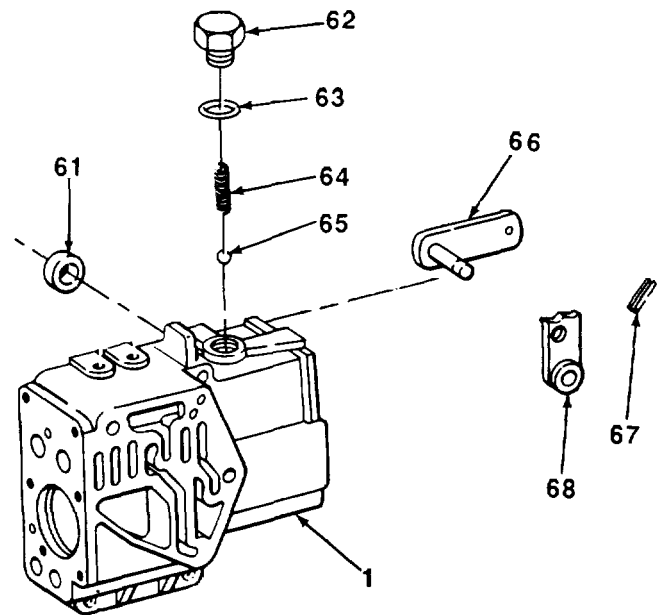
**c. CLEANING AND INSPECTION****WARNING**

Avoid contact with live steam. Live steam can burn skin, cause blindness, and other serious injury. Be sure to wear protective apron, gloves, and safety goggles when using live steam.

1. Using steam cleaner, clean outside, all holes and recesses, and foreign matter from inside control valve.

WARNING

Compressed air used for cleaning or drying purposes, or for clearing restrictions, should never exceed 30 psi (207 kPa). Wear protective clothing (goggles/shield, gloves, etc.) and use caution to avoid injury to personnel.

2. Flush valve body with clean water. Dry thoroughly with compressed air.

WARNING

Dry cleaning solvent, P-D-680, is toxic and flammable. Always wear protective goggles and gloves, and use only in a well-ventilated area. Avoid contact with skin, eyes, and clothes, and DO NOT breathe vapors. DO NOT use near open flame or excessive heat. The solvent's flash point is 100°F-138°F (38°C-59°C). If you become dizzy while using cleaning solvent, immediately get fresh air and medical help. If solvent contacts eyes, immediately wash your eyes and get medical aid.

3. Using dry cleaning solvent and clean rag, wipe all other metal parts clean. Dry with clean, dry rags.

8-20. REVERSER CLUTCH CONTROL VALVE ASSEMBLY MAINTENANCE (Con't).

- 4. Inspect valve body for cracks, breaks, and abnormal bends and wear.
- 5. Inspect all metal parts for cracks, breaks, abnormal bends, and excessive wear. Inspect threaded parts for damaged threads.
- 6. Inspect clutch control valve spring, relief valve spring, pressure valve spring, pressure regulating control valve spring and piston spring for cracks, bends, and breaks. Using spring tester, measure free lengths of springs. Free lengths must be:

• Piston spring	2 5/8 in. (6.7 cm)
• Clutch control valve spring	3/4in. (1.9 cm)
• Relief valve spring	2 1/16 in. (5.2 cm)
• Pressure valve spring	1 1/8 in. (2.9 cm)
• Pressure regulating control valve spring	2 9/16 in. (6.5 cm)

d. ASSEMBLY

- 1. Install remote levers (66 and 68) in valve body (1) with new spring pin (67).
- 2. If removed, install two seals (61).
- 3. Install ball bearing (65), spring (64), new preformed packing (63), and vent plug (62) in valve body (1).
- 4. Install pressure regulating control valve (60), spring (59), and three washers (shims) (58) in valve body (1).

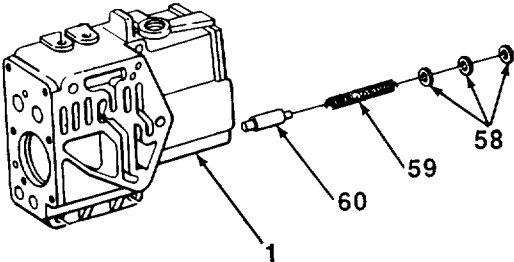

8-20. REVERSER CLUTCH CONTROL VALVE ASSEMBLY MAINTENANCE (Con't).

- 5. Install new gasket (52), retaining plate (51), and new gasket (50) on control cover (53) with retaining plate (49), new lockwasher (48), and screw (47).
- 6. Install control cover (53) on valve body (1) with five washers (54) and screws (55).
- 7. Install new preformed packing (57) on plug (56) and install in valve body (1).
- 8. Install two new preformed packings (46) on drain plugs (45) and install in valve body (1).

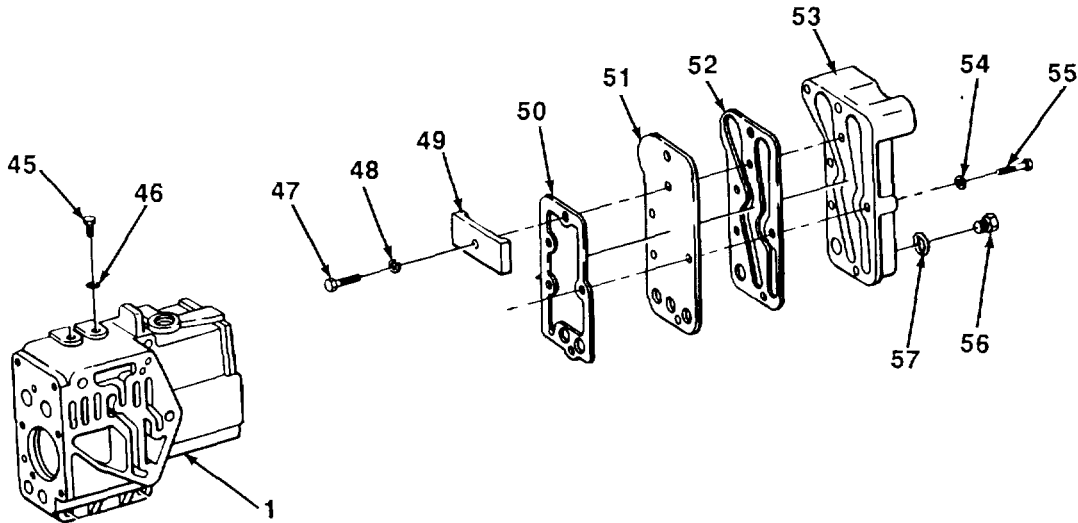

- 9. Install new preformed packing (42) on drain plug (41) and install in pump cover (24).
- 10. Install new preformed packing (43) on screw (44) and install in pump cover (24).

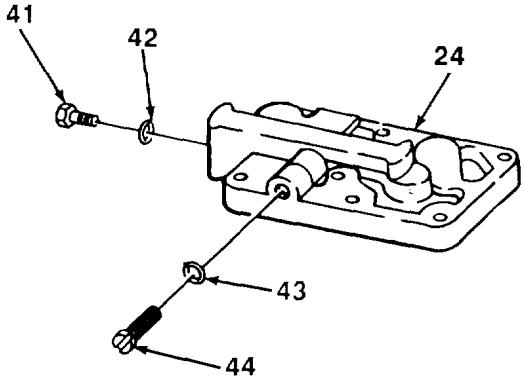

8-20. REVERSER CLUTCH CONTROL VALVE ASSEMBLY MAINTENANCE (Con't).

11. Install pin (31) in directional slide (29) with two retaining rings (30 and 32).
12. Insert directional slide (29) in valve body (1) and install retaining ring (28).
13. If removed, install spring pin (39) in pressure valve (40).
14. Install pin (34), spring (33), and pressure valve (40) in valve body (1).
15. Install relief valve (37), spring (38), clutch control valve (35), and spring (36) in valve body (1).

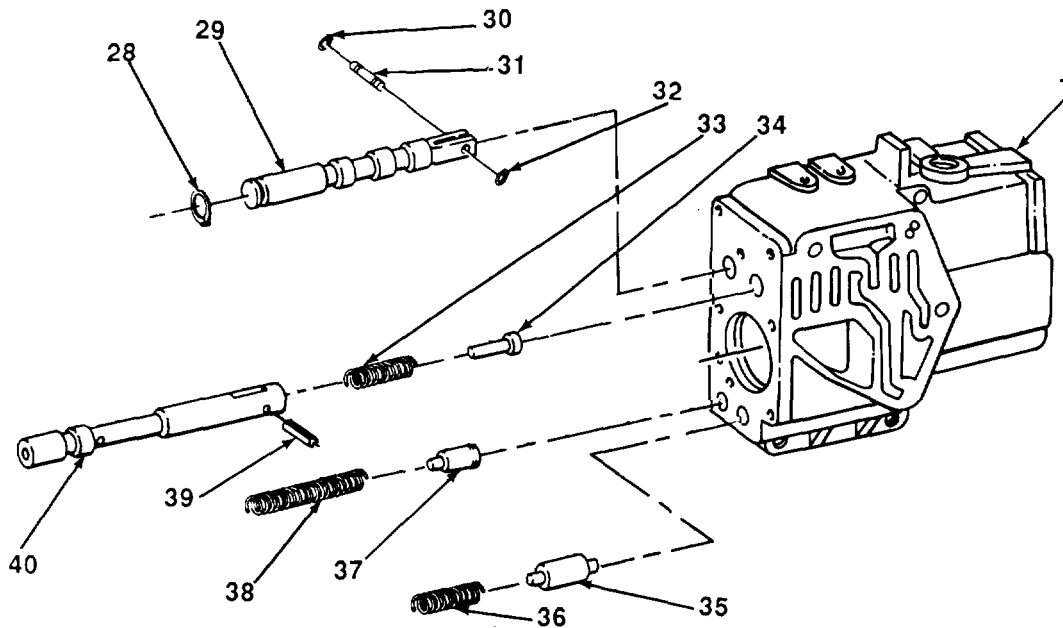

8-20. REVERSER CLUTCH CONTROL VALVE ASSEMBLY MAINTENANCE (Con't).

16. Install spring (27) and piston (26) in valve body (1).
17. Position new gasket (25) on valve body (1) and install pump cover (24) with six screws (22) and washers (23).

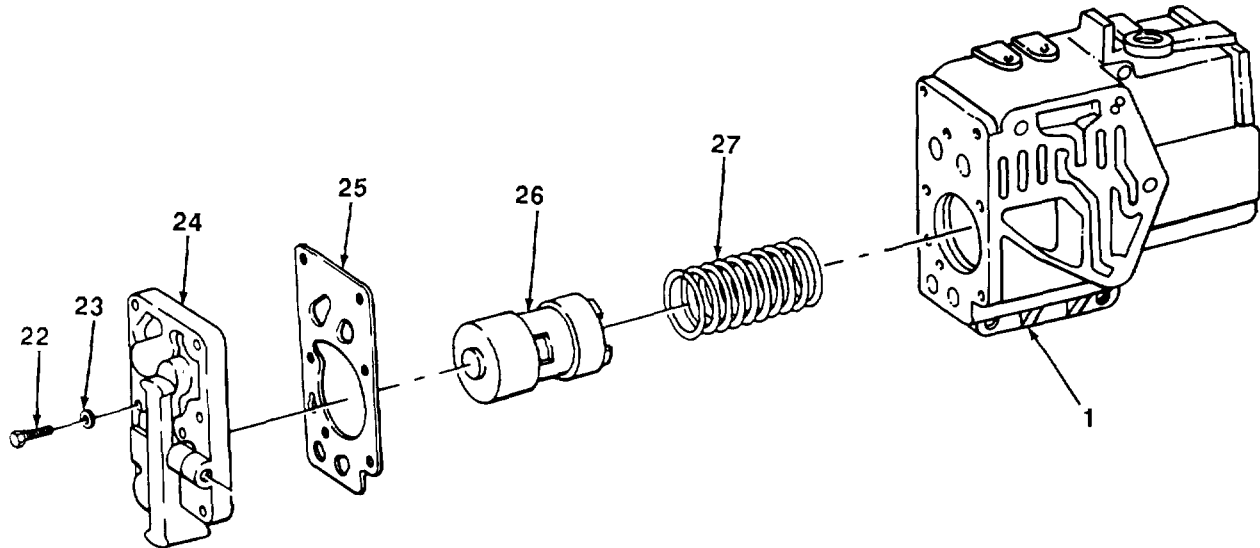
**e. INSTALLATION**

1. Install two new lockwashers (21) and screws (20) in valve body (1).
2. Position new gasket (17), retaining plate (16), and new gasket (15) on two screws (20).
3. Aline two screws (20) with holes in reverser housing and install valve body (1) with screws.
4. Install new lockwasher (18) and screw (19).

8-20. REVERSER CLUTCH CONTROL VALVE ASSEMBLY MAINTENANCE (Con't).

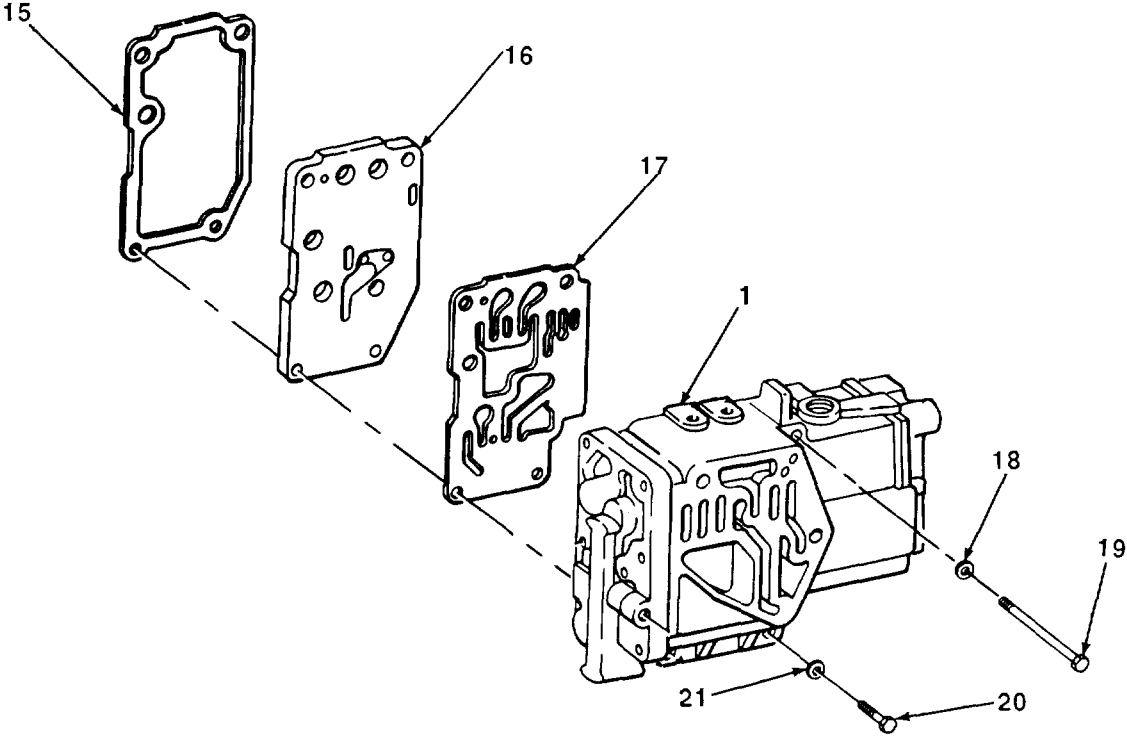

- 5. Install shaft (14) on valve body (1) and install new spring pin (11).
- 6. Install lever (13) on other end of shaft (14) with new spring pin (12).

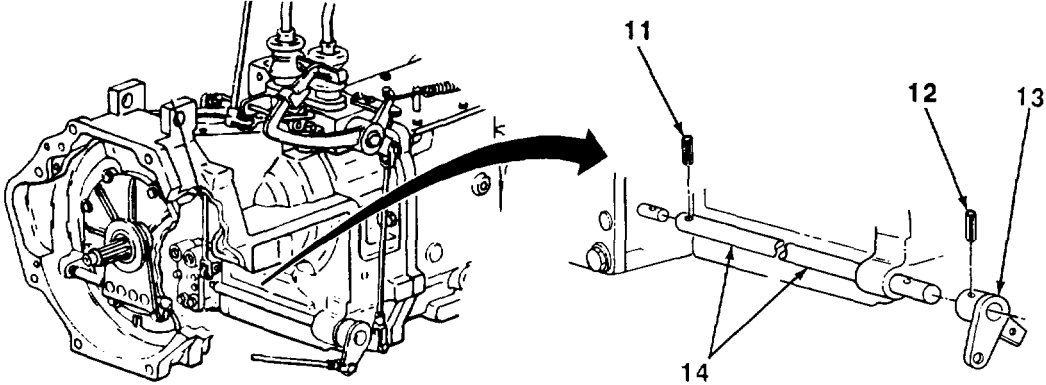

8-20. REVERSER CLUTCH CONTROL VALVE ASSEMBLY MAINTENANCE (Con't).

7. Position new gasket (10) and head (9) on valve body (1) and install with two screws (5) and washers (6).
8. Install new preformed packing (8) and elbow (7).
9. Install new preformed packing (2) and adapter (3).

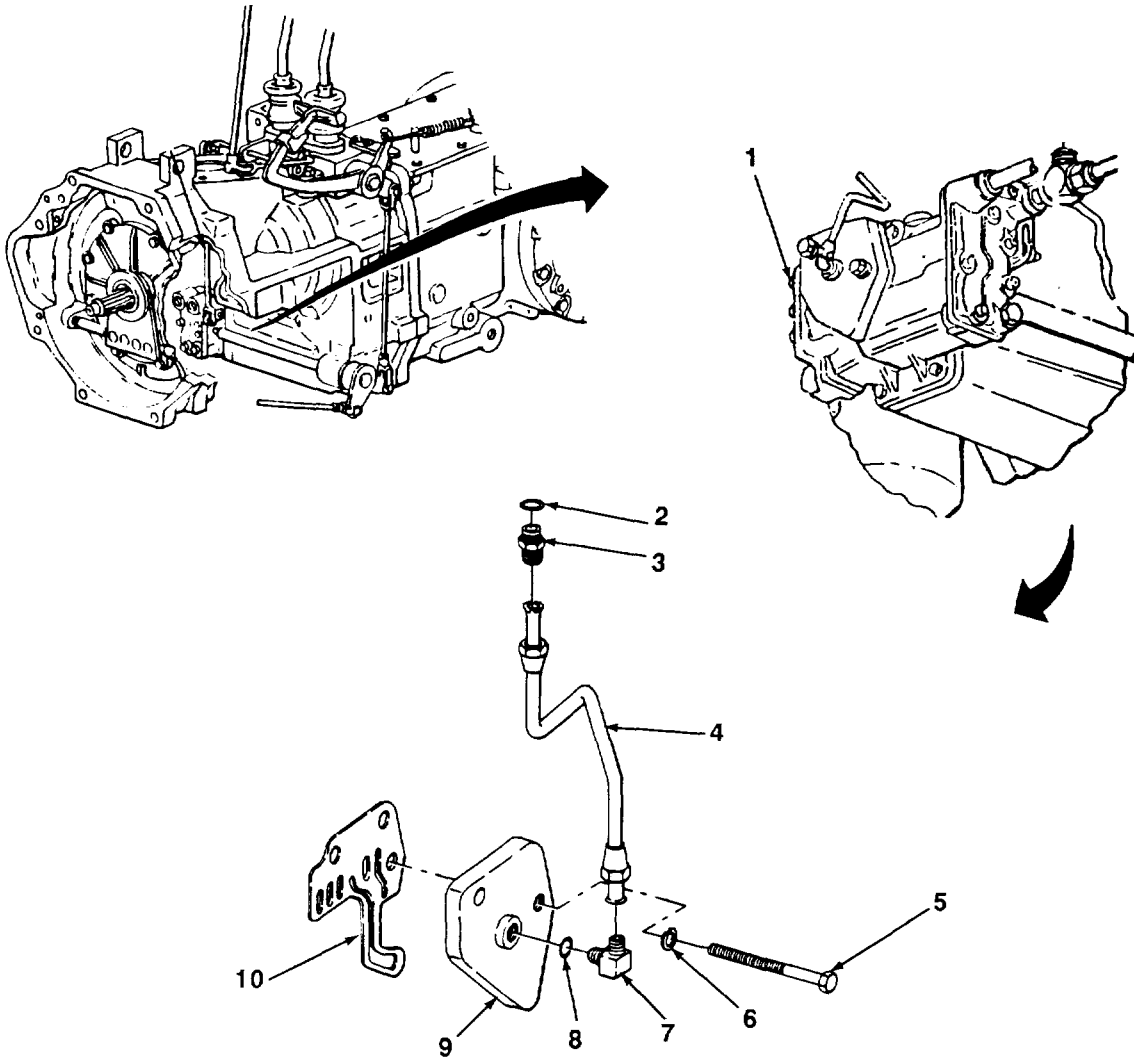
**FOLLOW-ON TASKS:**

- Connect oil lines (see TM 5-2420-222-20).
- Adjust speed gear assembly (reverser) (see TM 5-2420-222-20).

8-21. REVERSER OIL LINES REPLACEMENT.

This Task Covers:

a. Removal

b. Installation

Initial Setup:

Equipment Conditions:

- Reverser housing removed (see paragraph 8-16)

Materials/Parts:

- Eighteen preformed packings

Tools/Test Equipment:

- General mechanic's tool kit

a. REMOVAL

1. Remove front clutch pressure tube (4) from retaining plate (10) and lubrication tube (2). Remove and discard two preformed packings (3).
2. Remove lubrication tube (2) from front clutch. Remove and discard two preformed packings (1).
3. Remove reverse clutch pressure tube (13) from retaining plate (10) and reverse clutch. Remove and discard two preformed packings (5).
4. Remove transmission lubrication tube (8) from retaining plate (10) and transmission. Remove and discard two preformed packings (9).
5. Remove filter tube (6) from retaining plate (10). Remove and discard two preformed packings (7).
6. Remove rear clutch lubrication tube (12) from retaining plate (10) and rear clutch. Remove and discard two preformed packings (11).

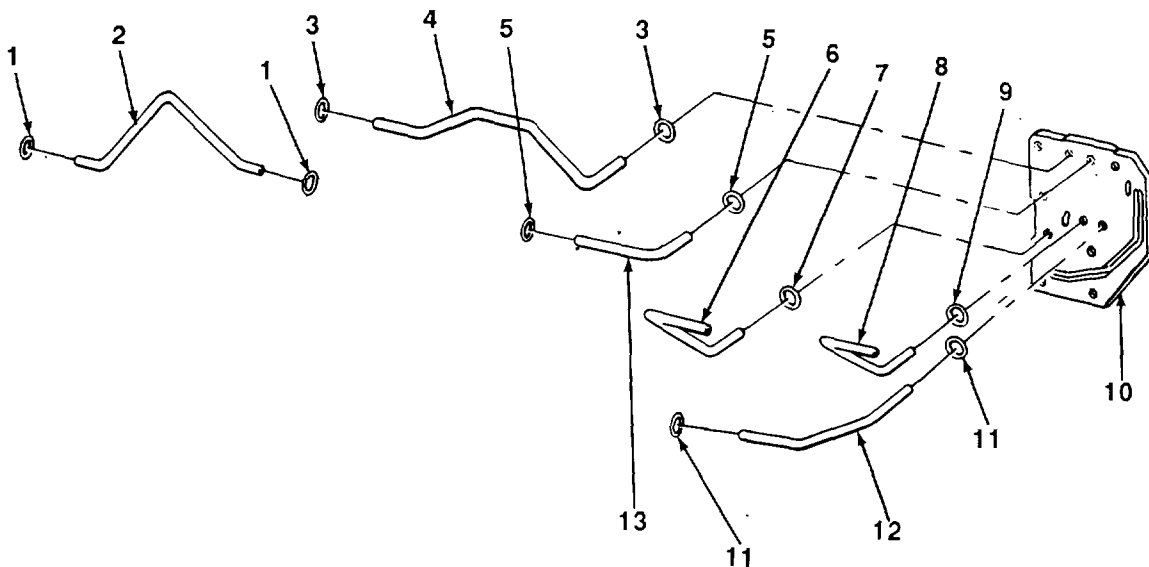

8-21. REVERSER OIL LINES REPLACEMENT (Con't).

- 7. Remove transmission oil pump inlet tube (22) and outlet tube (21) from transmission oil pump inlet and outlet. Remove and discard four preformed packings (20).
- 8. Remove two sleeve nuts (19) and preformed packings (18) from transmission oil pump (23). Discard preformed packings.
- 9. Remove two nuts (14), lockplates (15), and bracket (16).
- 10. If damaged, remove two studs (17).

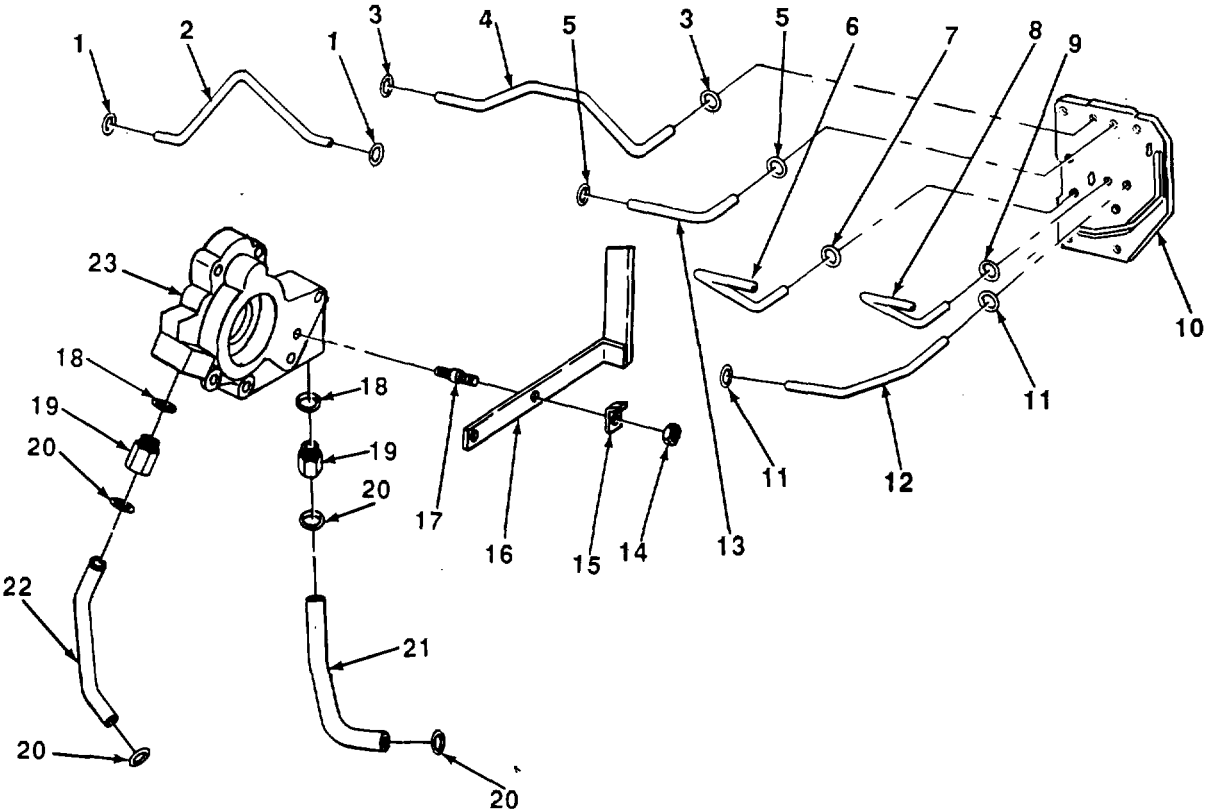

8-21. REVERSER OIL LINES REPLACEMENT (Con't).

b. INSTALLATION

1. If removed, install two studs (17).
2. Install bracket (16) with two lockplates (15) and nuts (14).
3. Install two new preformed packings (18) and sleeve nuts (19) in transmission oil pump (23).
4. Install transmission oil pump inlet tube (22) and outlet tube (21) in transmission oil pump inlet and outlet with four new preformed packings (20).
5. Install rear clutch lubrication tube (12) in retaining plate (10) with two new preformed packings (11).
6. Install filter tube (6) in retaining plate (10) with two new preformed packings (7).
7. Install transmission lubrication tube (8) in retaining plate (10) and transmission with two new preformed packings (9).
8. Install reverse clutch pressure tube (13) in retaining plate (10) and reverse clutch with two new preformed packings (5).
9. Install lubrication tube (2) in front clutch with new preformed packing (1).
10. Install front clutch pressure tube (4) on lubrication tube (2) using new preformed packings (1 and 3).
11. Install other end of front clutch pressure tube (4) in retaining plate (10) with new preformed packing (3).

FOLLOW-ON TASKS:

- Install reverser housing (see paragraph 8-16).

8-22. TRANSMISSION RELIEF VALVE MAINTENANCE.

This Task Covers:

- | | |
|----------------------------|-----------------|
| a. Removal | d. Assembly |
| b. Disassembly | e. Installation |
| c. Cleaning and Inspection | |

Initial Setup:

Equipment Conditions:

- Transmission drained (TM 5-2420-222-20).

Tools/Test Equipment:

- General mechanic's tool kit
- Field automotive shop set

Materials/Parts:

- Rags (Item 28, Appendix B)
- Dry cleaning solvent (Item 31, Appendix B)
- One preformed packing
- Two spring pins

General Safety Instructions:

- Dry cleaning solvent is flammable and must not be used near open flame. Use only in a well-ventilated area.

a. REMOVAL

Remove plug (6), preformed packing (7), and sleeve (8) with assembled parts from transmission (2). Discard preformed packing.

b. DISASSEMBLY

1. Place sleeve (8) with assembled parts in vise with caps.
2. Drive out two spring pins (4 and 5) from sleeve (8). Discard spring pins.
3. Remove spring (3) and valve (1) from sleeve (8).
4. Remove sleeve (8) from vise.

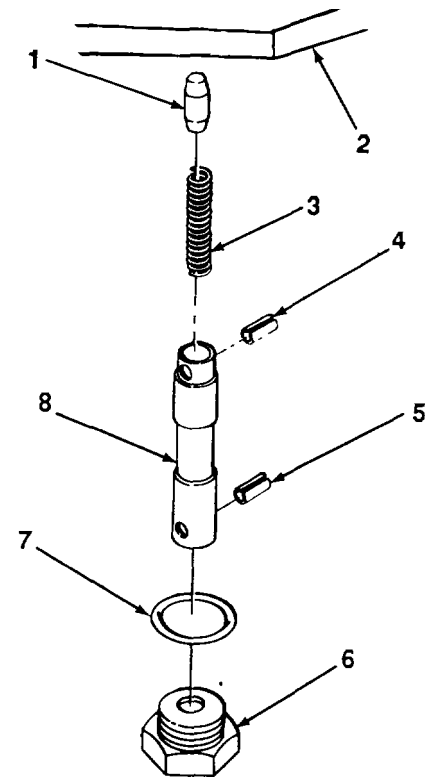

8-22. TRANSMISSION RELIEF VALVE MAINTENANCE (Con't).

c. CLEANING AND INSPECTION**WARNING**

Dry cleaning solvent, P-D-680, is toxic and flammable. Always wear protective goggles and gloves, and use only in a well-ventilated area. Avoid contact with skin, eyes, and clothes, and **DO NOT** breathe vapors. **DO NOT** use near open flame or excessive heat. The solvent's flash point is 100°F-138°F (38°C-59°C). If you become dizzy while using cleaning solvent, immediately get fresh air and medical help. If solvent contacts eyes, immediately wash your eyes and get medical aid.

1. Clean all metal parts with dry cleaning solvent. Dry thoroughly with clean, dry rags.
2. Inspect plug, sleeve, spring, and valve for cracks, breaks, and abnormal bends. Replace defective parts.

d. ASSEMBLY

1. Place sleeve (8) in vise with caps.
2. Install new spring pin (5) in sleeve (8).
3. Install spring (3) and valve (1) in sleeve (8).
4. Install new spring pin (4) in sleeve (8).
5. Remove sleeve (8) with assembled parts from vise.

e. INSTALLATION

Install sleeve (8) and plug (6) with new preformed packing (7) in transmission (2).

FOLLOW-ON TASKS:

- Fill transmission (see LO 5-2420-222-12).

8-23. TRANSMISSION OIL LINES REPLACEMENT.

This Task Covers:

a. Removal

b. Installation

Initial Setup:

Equipment Conditions:

- Transmission top cover removed (see paragraph 8-12 or 8-13).
- Transmission removed, if removing front transmission tube and adapter only (see paragraph 8-2).

Materials/Parts:

- Two preformed packings

Tools/Test Equipment:

- General mechanic's tool kit

a. REMOVAL**NOTE**

Washer Is used on serial numbers 235786-235999. Guard Is used on serial numbers 319995-342573.

1. Remove screw (9) and washer (10) or guard (11).

NOTE

Perform step 2 on loader backhoes with serial numbers 319995-342573. Skip step 2 on loader backhoes with serial numbers 235786-235999.

2. Remove spacer (17).
3. Remove accumulator (12) from transmission (6).
4. Remove preformed packing (15), roller bearing (13), and ball bearing (16) from accumulator (12). Discard preformed packing.
5. Remove tube (14) from transmission (6).

NOTE

Transmission must be removed to gain access for steps 6 through 8.

6. Remove two screws (2), three washers (1), nut (8), and bracket (7).
7. Remove adapter (5) from transmission (6).
8. Remove tube (3) and preformed packing (4) from adapter (5). Discard preformed packing.

b. INSTALLATION

1. Install tube (3) and new preformed packing (4) in adapter (5).
2. Install adapter (5) in transmission (6).
3. Install bracket (7), two screws (2), three washers (1), and nut (8).
4. Aline and install tube (14) in transmission (6).

8-23. TRANSMISSION OIL LINES REPLACEMENT.

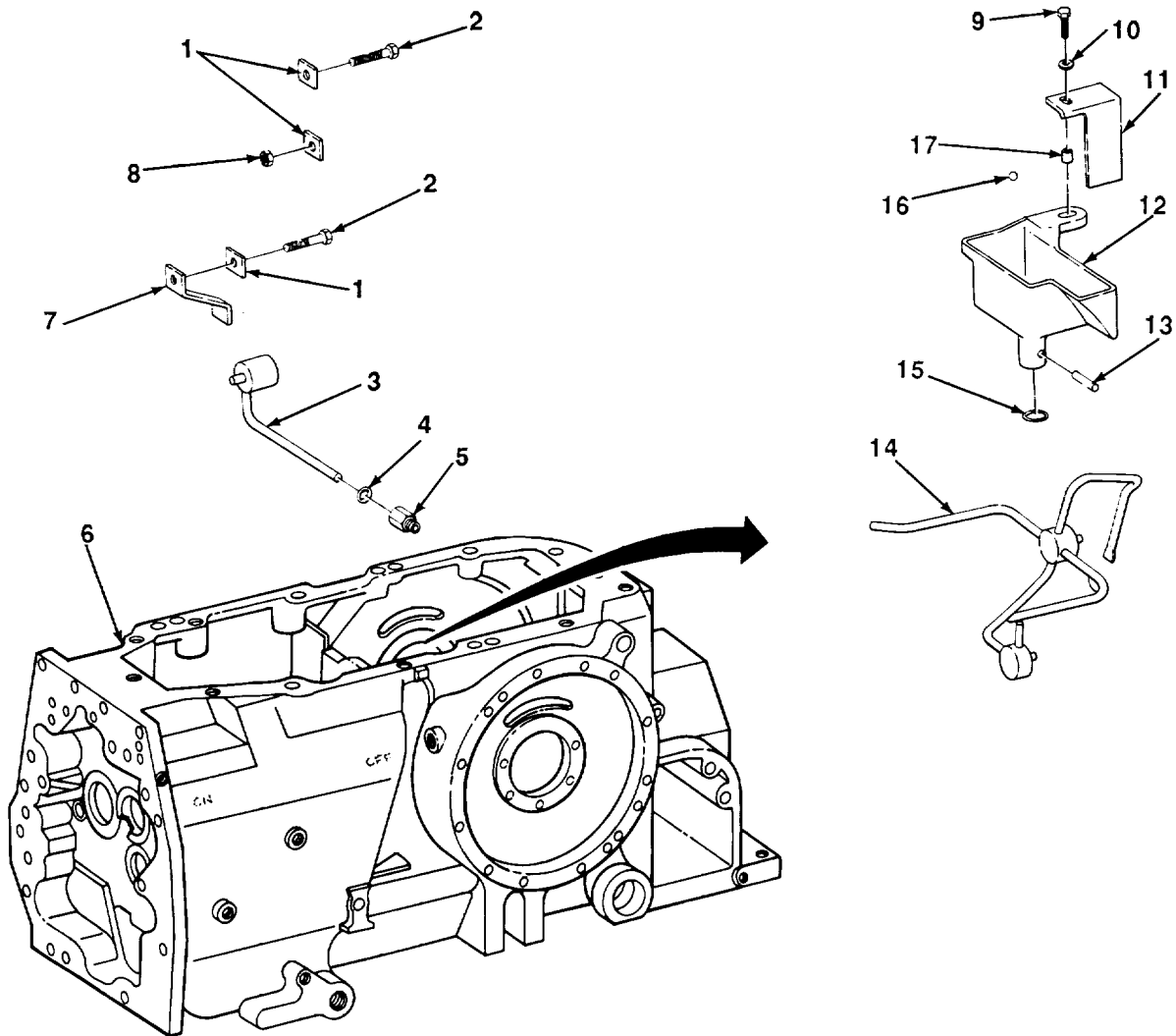

5. Install new preformed packing (15), ball bearing (16), and roller bearing (13) in accumulator (12).
6. Aline accumulator (12) and position in transmission (6).

NOTE

Perform step 7 on loader backhoes with serial numbers 319995-342573. Skip step 7 on loader backhoes with serial numbers 235786-235999.

7. Install spacer (17), guard (11), and screw (9).
8. Install washer (10) and screw (9).

FOLLOW-ON TASKS:

- Install transmission, if removed (see paragraph 8-2).
- Install transmission top cover (see paragraph 8-12 or 8-13).

CHAPTER 9
AXLE MAINTENANCE

Section I. FRONT AXLE MAINTENANCE

Paragraph Number	Paragraph Title	Page Number
9-1	Front Axle Assembly Maintenance	9-1
9-2	Wheel Spindles and Steering Arms Maintenance	9-4

9-1. FRONT AXLE ASSEMBLY MAINTENANCE.

This Task Covers:

- | | |
|----------------------------|-------------|
| a. Disassembly | c. Repair |
| b. Cleaning and Inspection | d. Assembly |

Initial Setup:

Equipment Conditions:

- Counterweight removed (see TM 5-2420-222-20).
- Frame assembly front support removed (see paragraph 12-1).

Materials/Parts:

- Rags (item 28, Appendix B)
- Dry cleaning solvent (Item 31, Appendix B)

Tools/Test Equipment:

- General mechanic's tool kit
- Field automotive shop set

General Safety Instructions:

- Dry cleaning solvent is used near open flame. Use only in a well-ventilated area.

References:

- TM 5-2420-222-20

a. DISASSEMBLY

1. Remove steering cylinder assemblies (see paragraph 11-2).
2. Remove tie-rods (see TM 5-2420-222-20).
3. Remove wheel spindles and steering arms (see paragraph 9-2).

9-1. FRONT AXLE ASSEMBLY MAINTENANCE (Con't).

4. If damaged, remove two grease fittings (1) from front axle (4).

CAUTION

Do not remove spring pins or bushings unless damaged. Removal may damage parts.

5. Remove two spring pins (5) from front axle (4).
 6. Using brass drift and hammer, drive bushing (3) out of front axle (4).
 7. Using mechanical gear and bearing puller, remove four bushings (2) from front axle (4).

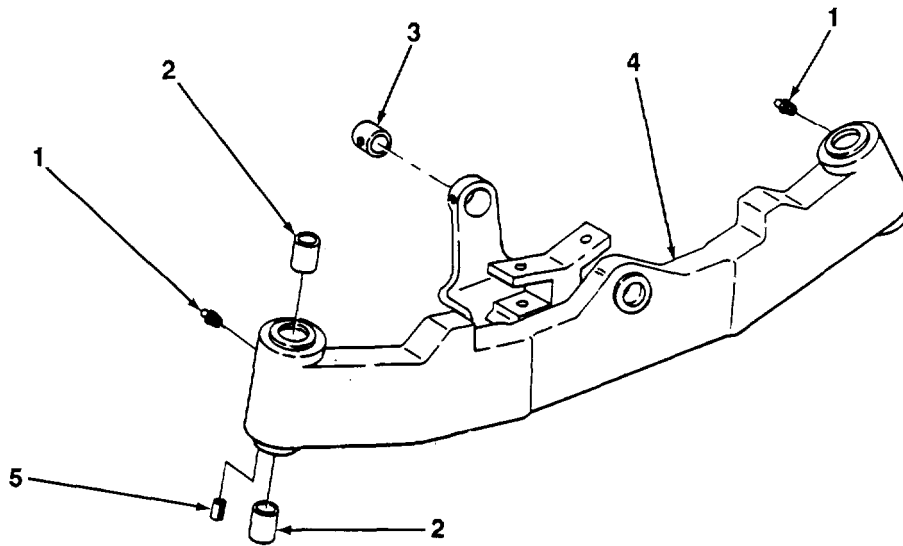
**b. CLEANING AND INSPECTION****WARNING**

Dry cleaning solvent, P-D-680, is toxic and flammable. Always wear protective goggles and gloves, and use only in a well-ventilated area. Avoid contact with skin, eyes, and clothes, and DO NOT breathe vapors. DO NOT use near open flame or excessive heat. The solvent's flash point is 100°F-138°F (38°C-59°C). If you become dizzy while using cleaning solvent, immediately get fresh air and medical help. If solvent contacts eyes, immediately wash your eyes and get medical aid.

1. Clean front axle with dry cleaning solvent and rags. Dry thoroughly with clean, dry rags.
2. Clean all other metal parts with dry cleaning solvent. Dry thoroughly with clean, dry rags.
3. Inspect all metal parts for cracks, breaks, abnormal bends, and damaged threads. Replace defective parts that cannot be repaired.

9-1. FRONT AXLE ASSEMBLY MAINTENANCE (Con't).

c. REPAIR

Restore damaged front axle (4) threads using screw threading set.

d. ASSEMBLY**NOTE**

Perform steps 1 through 3 only if bushings and spring pins were removed.

1. Position four bushings (2) in place on front axle (4) and tap in using brass drift and hammer.
2. Position bushing (3) in place on front axle (4). Using brass drift and hammer, drive bushing in front axle until flush with bottom of chamfer and grease fitting holes aline.
3. Install two spring pins (5) in front axle (4).
4. If removed, install two grease fittings (1) in front axle (4).
5. Install wheel spindles and steering arms (see paragraph 9-2).
6. Install tie-rods (see TM 5-2420-222-20).
7. Install steering cylinder assemblies (see paragraph 11-2).

FOLLOW-ON TASKS:

- Install frame assembly front support (see paragraph 12-1).
- Install counterweight (see TM 5-2420-222-20).

9-2. WHEEL SPINDLES AND STEERING ARMS MAINTENANCE.

This Task Covers:

- | | |
|----------------------------|-----------------|
| a. Removal | c. Repair |
| b. Cleaning and Inspection | d. Installation |
-

Initial Setup:

Equipment Conditions:

- Front wheel bearings and hub removed (see TM 5-2420-222-20).

Tools/Test Equipment:

- General mechanic's tool kit
- Field automotive shop set

Materials/Parts:

- Rags (Item 28, Appendix B)
- Dry cleaning solvent (Item 31, Appendix B)
- One lockwasher
- Two cotter pins

General Safety Instructions:

- Dry cleaning solvent is flammable and must not be used near open flame. Use only in a well-ventilated area.

Personnel Required: Two

NOTE

Both wheel spindles and steering arms are maintained the same way, except as noted. Left side is shown. Repeat procedure for right side as required.

a. REMOVAL

NOTE

Loader backhoes with serial numbers 235786-235999 have two steering cylinders. Loader backhoes with serial numbers 319995-342573 have one on left side. When removing right side wheel spindle and steering arm on loader backhoes with serial numbers 319995-342573, skip steps 1 through 3.

1. Remove cotter pin (6) from steering arm (7) and pin (8). Discard cotter pin.
2. Using brass drift and hammer, drive pin (8) out of steering arm (7) and steering cylinder (4).
3. Move steering cylinder (4) away from steering arm (7).
4. Remove cotter pin (1) from tie-rod end socket (5) and nut (2). Remove nut and washer (3). Discard cotter pin.
5. Using mechanical gear and bearing puller, remove tie-rod end socket (5) with assembled parts from steering arm (7).
6. Remove screw (9), lockwasher (10), washer (11), and two washers (12) from steering arm (7) and wheel spindle (13). Discard lockwasher.
7. Using center punch and hammer, match-mark steering arm (7) and wheel spindle (13).
8. While assistant supports wheel spindle (13), remove steering arm (7) from wheel spindle and front axle (14), using mechanical gear and bearing puller.

9-2. WHEEL SPINDLES AND STEERING ARMS MAINTENANCE (Con't).

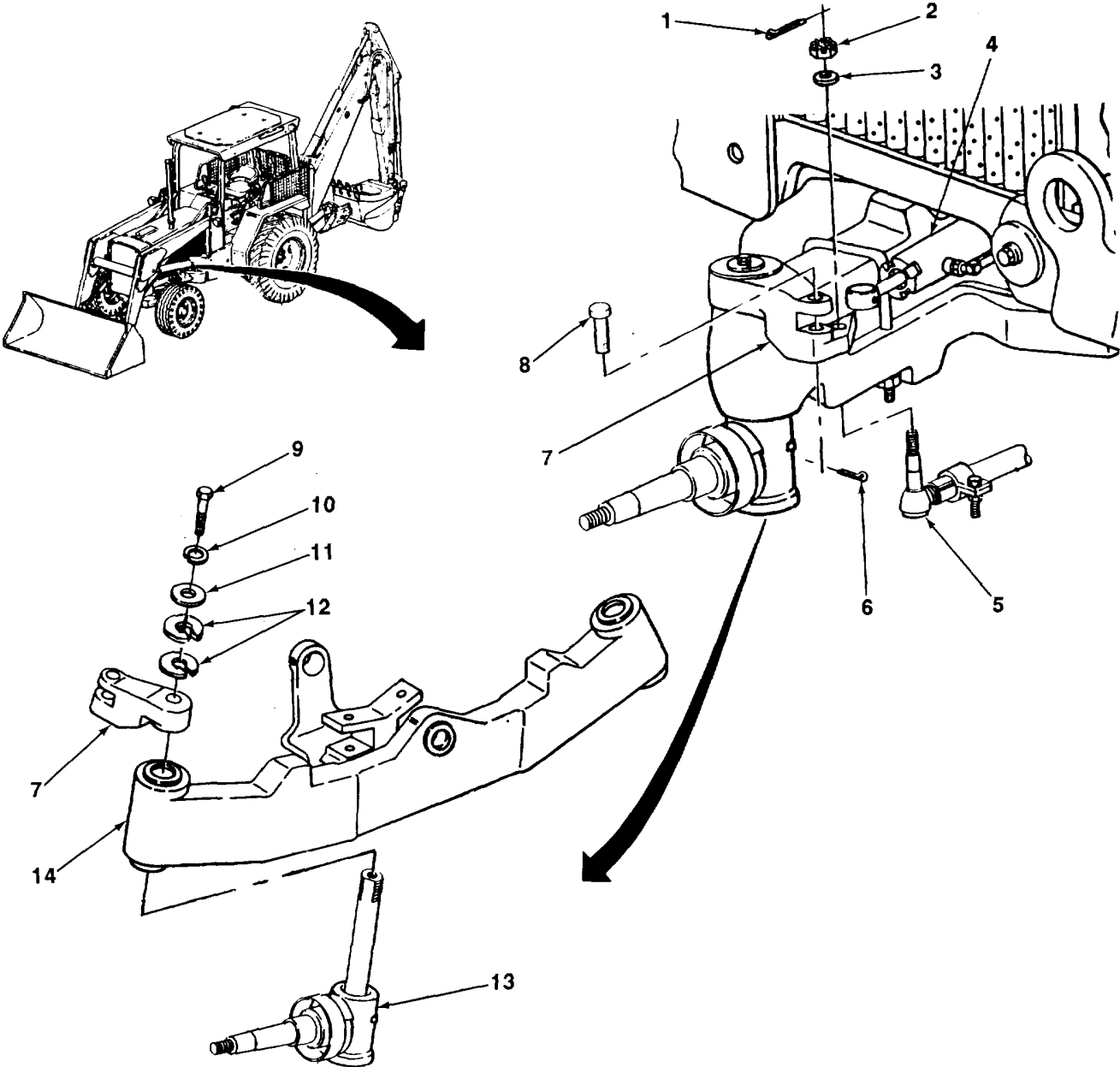

9-2. WHEEL SPINDLES AND STEERING ARMS MAINTENANCE (Con't).

9. With the aid of an assistant, remove wheel spindle (13) with two assembled thrust washer bearings (16) from front axle (14) and two bushings (17).
10. Remove two assembled thrust washer bearings (16) from wheel spindle (13).

CAUTION

Do not remove spring pin unless damaged. Removal may damage parts.

11. Remove spring pin (15) from wheel spindle (13).

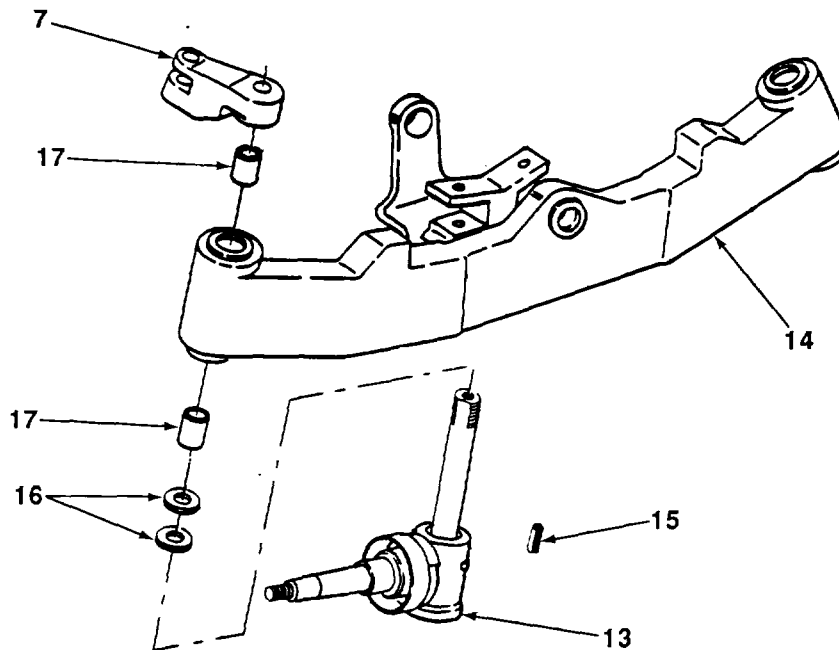
**b. CLEANING AND INSPECTION****WARNING**

Dry cleaning solvent, P-D-680, is toxic and flammable. Always wear protective goggles and gloves, and use only in a well-ventilated area. Avoid contact with skin, eyes, and clothes, and **DO NOT** breathe vapors. **DO NOT** use near open flame or excessive heat. The solvent's flash point is 100°F-138°F (38°C-59°C). If you become dizzy while using cleaning solvent, immediately get fresh air and medical help. If solvent contacts eyes, immediately wash your eyes and get medical aid.

1. Clean all metal parts with dry cleaning solvent and rags. Dry thoroughly with clean, dry rags.

9-2. WHEEL SPINDLES AND STEERING ARMS MAINTENANCE (Con't).

2. Inspect metal parts for cracks, breaks, and abnormal bends.
3. Inspect wheel spindle and steering arm for damaged splines and threads.

c. REPAIR

1. Restore damaged wheel spindle (13) threads using screw threading set.
2. If wheel spindle (13) or steering arm (7) splines are damaged, restore splines using smooth-cut flat file.

d. INSTALLATION**NOTE**

Perform step 1 only if spring pin was removed.

1. Tap spring pin (15) in wheel spindle (13).
2. Install two assembled thrust washer bearings (16) on wheel spindle (13) with slot of bottom thrust washer bearing aligned with spring pin (15).
3. With the aid of an assistant, align one slot of top thrust washer bearing (16) with spring pin (15), and install wheel spindle (13) in front axle (14) and two bushings (17).
4. Align match-marks on steering arm (7) and wheel spindle (13).

9-2.WHEEL SPINDLES AND STEERING ARMS MAINTENANCE (Con't).

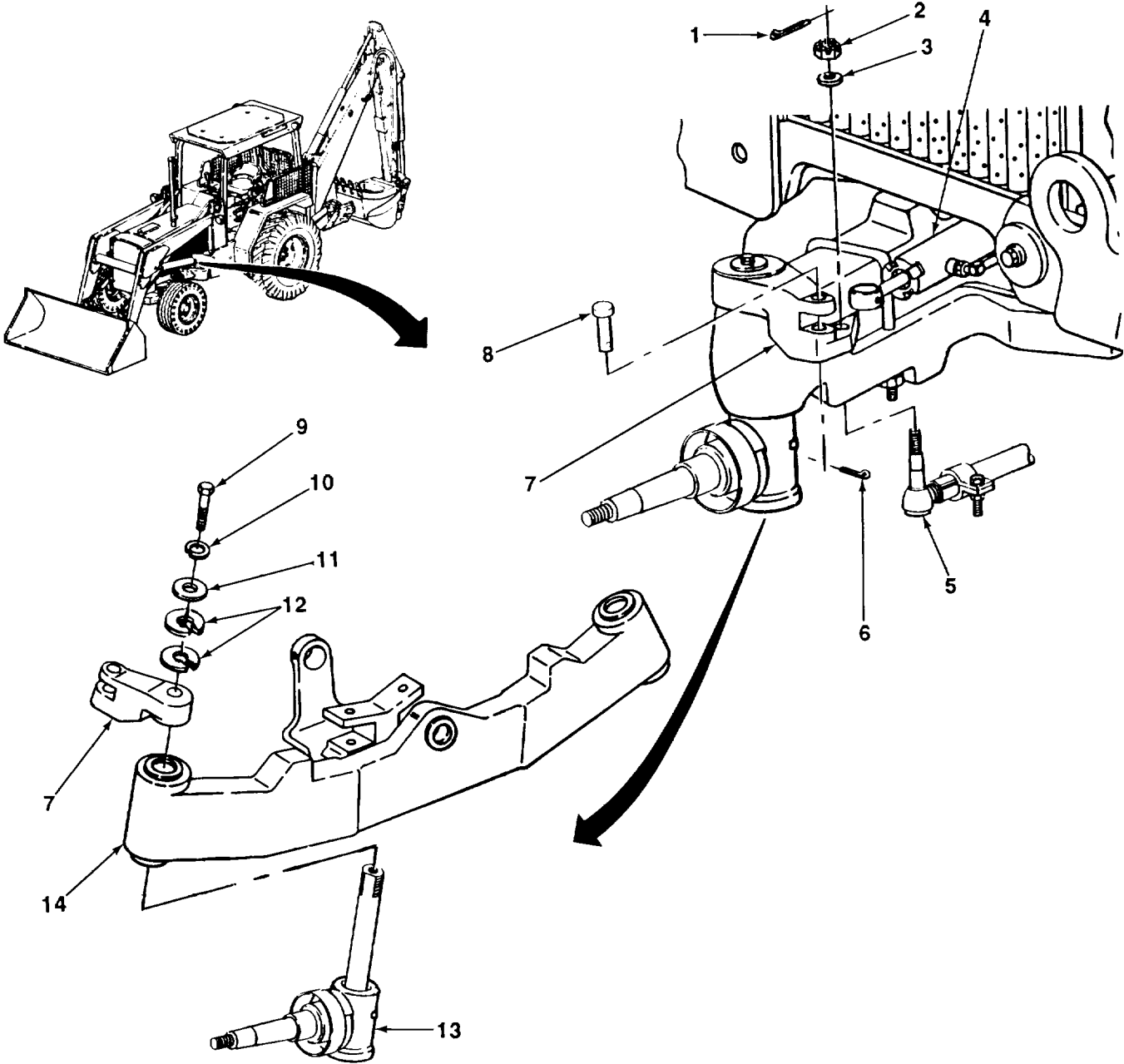

9-2. WHEEL SPINDLES AND STEERING ARMS MAINTENANCE (Con't).

5. Install two washers (12), washer (11), new lockwasher (10), and screw (9) in steering arm (7) and wheel spindle (13). Torque screw to 170 lb.-ft. (231 N•m).
6. Using hardwood block and hammer, tap steering arm (7) until seated in wheel spindle (13).
7. Torque screw (9) to 170 lb.-ft. (231 N•m).
8. Using dial indicator, measure end play between wheel spindle (13) and front axle (14). End play must be 0.045-0.050 in. (1.143-1.270 mm).

NOTE

If end play is within specification, skip step 9.

9. Remove screw (9), lockwasher (10), washer (11), and two washers (12) from steering arm (7) and wheel spindle (13). Add or remove washers (12) as required to meet specification, then repeat steps 5 through 8.
10. Using pry bar, place tie-rod end socket (5) with assembled parts on steering arm (7).
11. Install washer (3) and nut (2) on tie-rod end socket (5) and steering arm (7). Ensure that cotter pin hole in tie-rod end socket aligns with slots in nut.
12. Install new cotter pin (1) in tie-rod end socket (5) and nut (2).

NOTE

Loader backhoes with serial numbers 235786-235999 have two steering cylinders. Loader backhoes with serial numbers 319995-342573 have one on left side. When installing right side wheel spindle and steering arm on loader backhoes with serial numbers 319995-342573, skip steps 13 through 15.

13. Move steering cylinder (4) in position on steering arm (7).
14. Tap pin (8) in steering arm (7) and steering cylinder (4).
15. Install new cotter pin (6) in steering arm (7) and pin (8).

FOLLOW-ON TASKS:

- Install front wheel bearings and hub (see TM 5-2420-222-20).
- Adjust tie-rods (see TM 5-2420-222-20).

Section II. REAR AXLE MAINTENANCE

9-3. REAR AXLE HOUSING, SHAFTS, SEALS, BEARINGS, AND PLANETARY PINION CARRIER MAINTENANCE.

This Task Covers:

- | | |
|----------------------------|-----------------|
| a. Removal | d. Repair |
| b. Disassembly | e. Assembly |
| c. Cleaning and Inspection | f. Installation |

Initial Setup:

Equipment Conditions:

- Roll-over protective structure or canopy rear mounts removed (see paragraph 13-4).

NOTE

Perform the following only if removing left rear axle housing.

- Battery tray removed (see TM 5-2420-222-20).

NOTE

Perform the following only if removing right rear axle housing.

- Battery ground cable disconnected (see TM 5-2420-222-20).
- Parking brake lever support removed (see TM 5-2420-222-20).
- Loader control valve and mounting bracket removed (see TM 5-2420-222-20).
- Jaw control valve and mounting bracket removed (see TM 5-2420-222-20).

Tools/Test Equipment:

- General mechanic's tool kit
- Field automotive shop set

References:

- TM 5-2420-222-20
- TM 9-214

Materials/Parts:

- Grease (Item 22, Appendix B)
- Rags (Item 28, Appendix B)
- Tin alloy solder (Item 30, Appendix B)
- Dry cleaning solvent (Item 31, Appendix B)
- Marker tags (Item 32, Appendix B)
- Marker tags (Item 32, Appendix B)
- Pressure sensitive tape (Item 38, Appendix B)
- One gasket
- One grease fitting
- One plain encased seal
- Two 9/16 in. -12 UNC x 5 in. screws (serial numbers 235786-235999)
- Two 3/4 in.-10 UNC x 5 in. screws (serial numbers 319995-342573)
- Five preformed packings
- Shims (as required)

Personnel Required: Two

General Safety Instructions:

- Dry cleaning solvent is flammable and must not be used near open flame. Use only in a well-ventilated area.
- Hot oil gives off highly flammable fumes and must not be used near open flame.

NOTE

Left and right rear axle housings, shafts, seals, bearings, and final drive planetary pinions are maintained the same way, except as noted. Repeat steps as required for other side.

9-3. REAR AXLE HOUSING, SHAFTS, SEALS, BEARINGS, AND PLANETARY PINION CARRIER MAINTENANCE (Con't).**a. REMOVAL****WARNING**

Use extreme caution when handling heavy parts. Lifting device is required when parts weigh over 50 lb (23 kg) for a single person lift, over 100 lb (45 kg) for a two person lift, and over 150 lb (68 kg) for a three or more person lift. Keep clear of heavy parts supported only by lifting device. Failure to follow this warning may cause serious injury or death to personnel.

NOTE

Use a drain pan to catch any draining fluid. Clean up all spills.

1. Remove connector (2) from brake light switch terminal (3).
2. Place drain pan under rear axle housing (1) and remove brake oil line (5) from elbow (4).

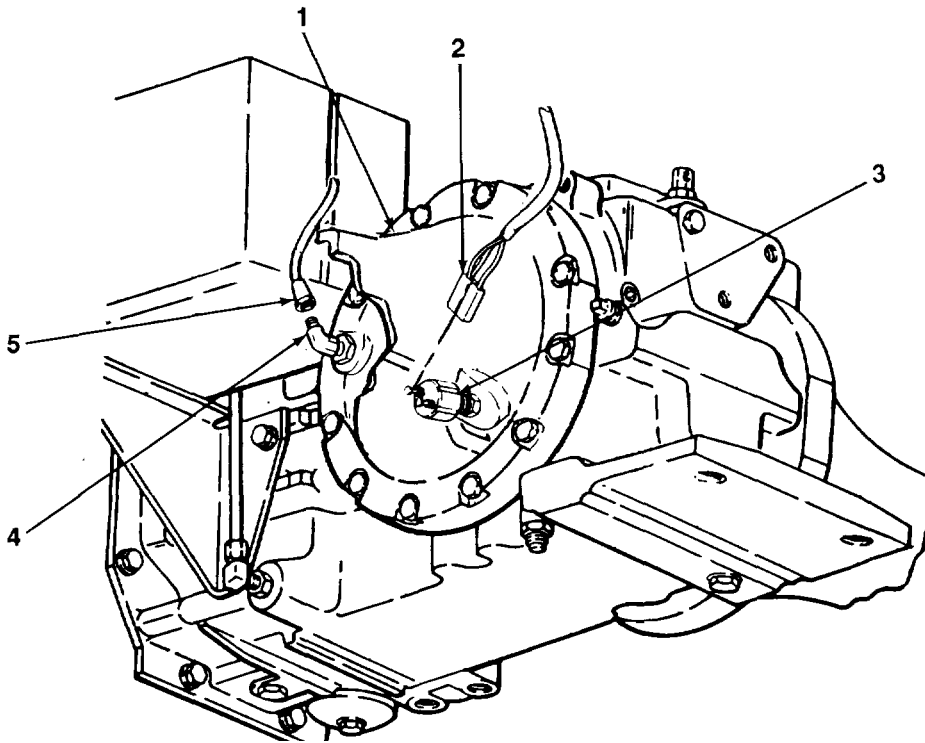

TA701439

9-3. REAR AXLE HOUSING, SHAFTS, SEALS, BEARINGS, AND PLANETARY PINION CARRIER MAINTENANCE (Con't).

3. Support transmission (9) with wood blocks.
4. Drain transmission (see TM 5-2420-222-20).

NOTE

Steps 5 through 10 apply only to right side rear axle housing.

5. Using lifting device, support rear axle housing (1).
6. Place drain pan under rear axle housing (1).
7. Remove eight screws (10) from rear axle housing (1) and transmission (9).
8. Using lifting device, remove rear axle housing (1) with assembled parts and gasket (6) from transmission (9) and final drive shaft (7) and set on wood blocks. Discard gasket.
9. Remove final drive shaft (7) and assembled brake disk (8) from drive shaft hub and transmission (9).
10. Using center punch and ball-peen hammer, match-mark brake disk (8) and final drive shaft (7). Remove brake disk from final drive shaft.

9-3. REAR AXLE HOUSING, SHAFTS, SEALS, BEARINGS, AND PLANETARY PINION CARRIER MAINTENANCE (Con't).

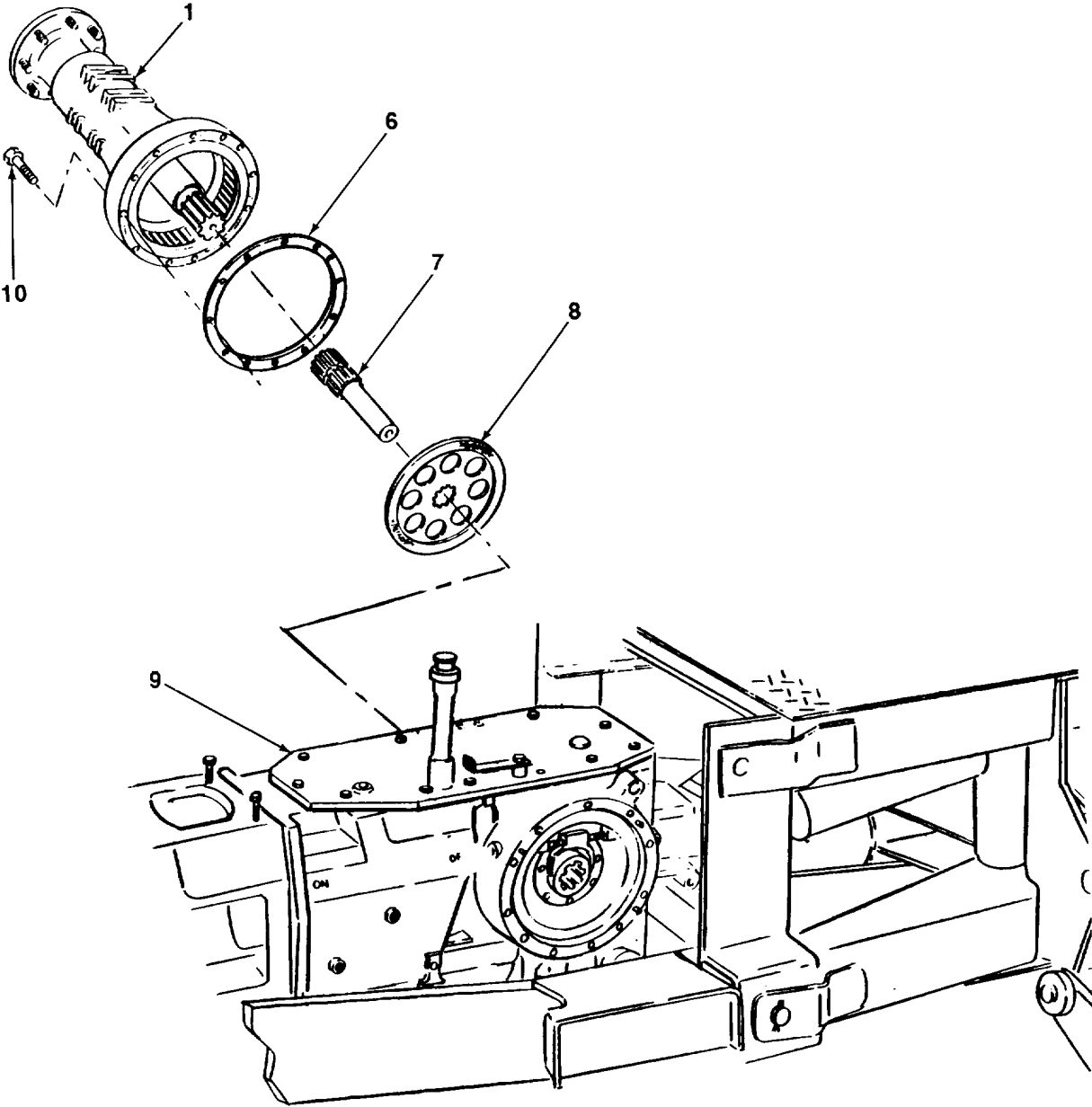

TA701440

RIGHT SIDE REAR AXLE HOUSING

9-3. REAR AXLE HOUSING, SHAFTS, SEALS, BEARINGS, AND PLANETARY PINION CARRIER MAINTENANCE (Con't).

NOTE

Steps 11 through 17 apply only to left side rear axle housing.

11. Using lifting device, support rear axle housing (1).
12. Place drain pan under rear axle housing (1).
13. Remove twelve screws (10) from rear axle housing (1) and transmission (9).
14. Using lifting device, remove rear axle housing (1) with assembled parts and gasket (6) from transmission (9) and final drive shaft (7) and set on wood blocks. Discard gasket.
15. Remove final drive shaft (7) and assembled brake disk (8) from collar (11) and transmission (9).
16. Using center punch and ball-peen hammer, match-mark brake disk (8) and final drive shaft (7).
17. Remove brake disk (8) from final drive shaft (7).
18. Pry with two pry bars on opposite sides of brake pressure plate (12) at several positions until loose. Remove brake pressure plate and assembled parts from rear axle housing (1).
19. Remove two preformed packings (13 and 14) from brake pressure plate (12). Discard preformed packings.

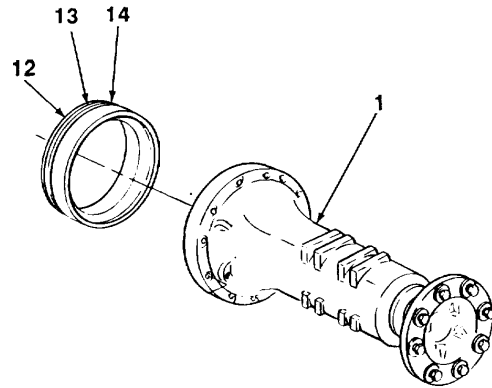

TA701441

9-3. REAR AXLE HOUSING, SHAFTS, SEALS, BEARINGS, AND PLANETARY PINION CARRIER MAINTENANCE (Con't).

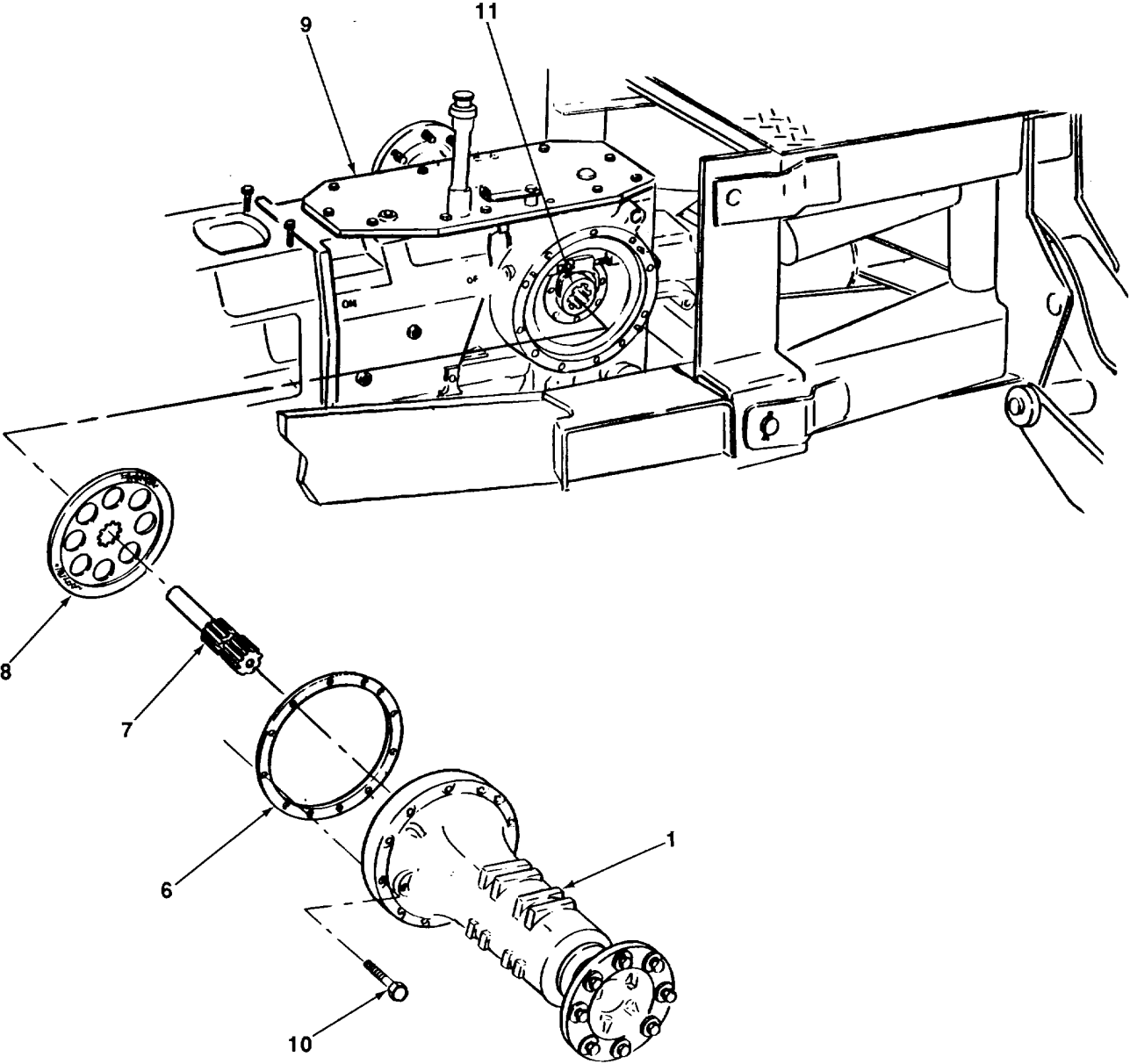

TA701442

LEFT SIDE REAR AXLE HOUSING

9-3. REAR AXLE HOUSING, SHAFTS, SEALS, BEARINGS, AND PLANETARY PINION CARRIER MAINTENANCE (Con't).

b. DISASSEMBLY

- 1. Open cap (19) and remove hydraulic bleeder valve (20) and cap from rear axle housing (1).
- 2. Remove elbow (24) and preformed packing (23) from connector (22). Discard preformed packing.
- 3. Remove connector (22) and preformed packing (21) from rear axle housing (1). Discard preformed packing.
- 4. Remove grease fitting (16) from rear axle housing (1). Discard grease fitting.
- 5. Remove connector (17) and preformed packing (18) from rear axle housing (1). Discard preformed packing.

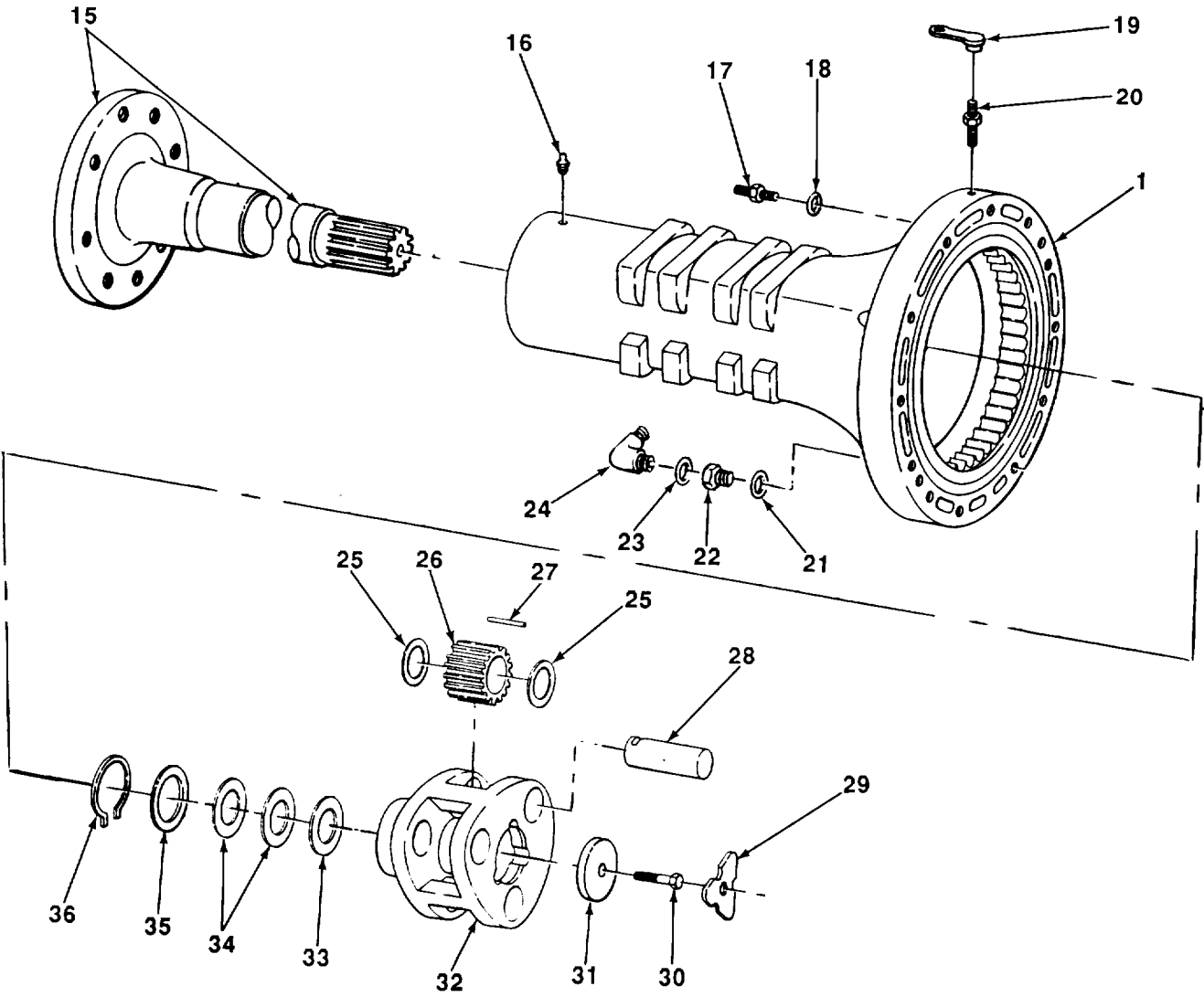

TA701443

9-3. REAR AXLE HOUSING, SHAFTS, SEALS, BEARINGS, AND PLANETARY PINION CARRIER MAINTENANCE (Con't).

6. Remove screw (30), lockplate (29), and washer (31) from axle shaft (15) and planetary pinion carrier (32).
7. Remove spacer (33) and shims (34) from axle shaft (15) and planetary pinion carrier (32).
8. Remove planetary pinion carrier (32) with assembled parts and thrust washer bearing (35) from axle shaft (15) and rear axle housing (1).
9. Remove retaining ring (36), three planetary pinion shafts (28), spur gears (26), 69 roller bearings (27), and six thrust washer bearings (25) from planetary pinion carrier (32).
10. Remove lifting device from rear axle housing (1).
11. Using hammer and brass drift, drive axle shaft (15) out until free of tapered cone and rollers (43) and rear axle

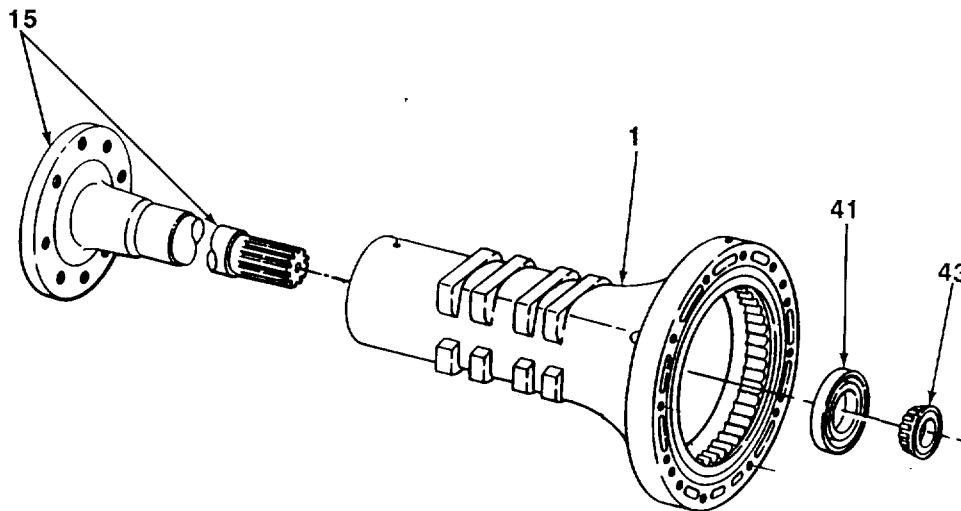

12. Remove axle shaft (15) from rear axle housing (1).
13. Remove tapered cone and rollers (43) from rear axle housing (1).
14. Using mechanical gear and bearing puller kit, remove plain encased seal (41) from rear axle housing (1). Discard plain encased seal.

TA701444

9-3. REAR AXLE HOUSING, SHAFTS, SEALS, BEARINGS, AND PLANETARY PINION CARRIER MAINTENANCE (Con't).

CAUTION

Do not remove oil seal cup, bearing cups, and straight pins from rear axle housing, or roller bearing and oil seal from axle shaft, unless damaged. Removal may damage parts.

15. Using mechanical gear and bearing puller kit, remove oil seal cup (38) from rear axle housing (1).
16. Using mechanical gear and bearing puller kit, remove bearing cup (40) from rear axle housing (1).
17. Using mechanical gear and bearing puller kit, remove bearing cup (43) from rear axle housing (1).
18. Using mechanical gear and bearing puller kit, remove roller bearing (39) from axle shaft (15).
19. Using mechanical gear and bearing puller kit, remove oil seal (37) from axle shaft (15).
20. Remove three straight pins (44) from rear axle housing (1).

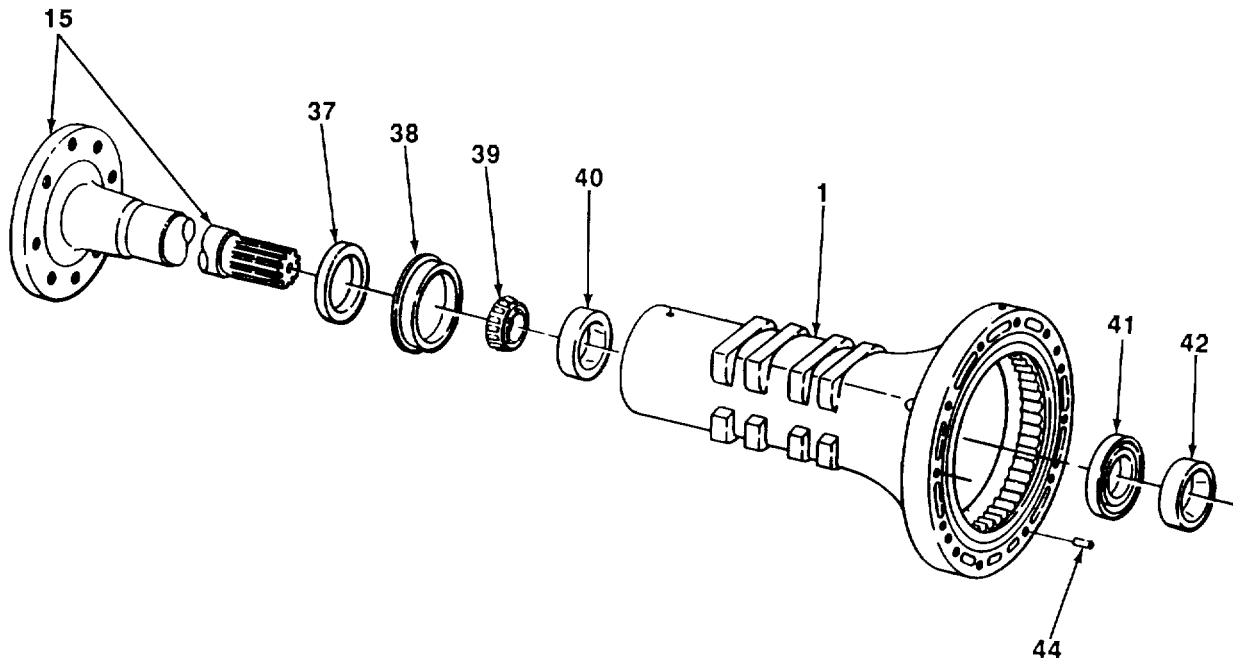

c. CLEANING AND INSPECTION

WARNING

Dry cleaning solvent, P-D-680, is toxic and flammable. Always wear protective goggles and gloves, and use only in a well-ventilated area. Avoid contact with skin, eyes, and clothes, and DO NOT breathe vapors. DO NOT use near open flame or excessive heat. The solvent's flash point is 100°F-138°F (38°C-59°C). If you become dizzy while using cleaning solvent, immediately get fresh air and medical help. If solvent contacts eyes, immediately wash your eyes and get medical aid.

9-3. REAR AXLE HOUSING, SHAFTS, SEALS, BEARINGS, AND PLANETARY PINION CARRIER MAINTENANCE (Con't).

1. Clean all metal parts with dry cleaning solvent and rags. Dry thoroughly with clean, dry rags.
2. Clean and Inspect bearings (see TM 9-214).
3. Inspect metal parts for cracks, breaks, and abnormal bends.
4. Inspect rear axle housing and axle shaft for damaged threads.
5. Inspect rear axle housing, axle shaft, three planetary pinion carrier spur gears, and final drive shaft for scoring, pitting, chipped, or worn gear teeth.
6. Inspect axle shaft oil seal for excessive wear, cracks, or signs of leaking. Replace if defective.

d. REPAIR

Restore rear axle housing (1) or axle shaft (15) threads using screw threading set.

e. ASSEMBLY
NOTE

Perform steps 1 through 6 only if oil seal cup, bearing cups, and straight pins were removed from rear axle housing, or roller bearing and oil seal were removed from axle shaft.

1. Install three straight pins (44) in face of rear axle housing (1) with plastic-faced hammer.
2. Install oil seal (37) on axle shaft (15) with plastic-faced hammer.

WARNING

Hot oil gives off highly flammable fumes. When heating parts in oil, do not smoke or allow open flame nearby. Make sure area is well-ventilated. Heat parts only in tank with lid which can be closed quickly to extinguish fire. Wear eye protection, protective gloves and clothing when heating parts in oil and handling hot parts. Hot oil and hot parts can cause severe burns.

CAUTION

Do not heat roller bearing over 300°F (149 C). If overheated, temper of bearing will be affected, causing roller bearing failure.

3. Using oil heating equipment, heat roller bearing (39) in oil. When hot, position roller bearing in place on axle
4. Install bearing cup (40) in rear axle housing (1) and tap in place with brass drift and ball-peen hammer.
5. Install oil seal cup (38) in rear axle housing (1) and tap in place with plastic-faced hammer.
6. Install bearing cup (42) in rear axle housing (1) and tap in place with brass drift and ball-peen hammer.
7. Install new plain encased seal (41) in rear axle housing (1) and tap in place with brass drift and ball-peen hammer.
8. Cover axle shaft (15) splines with pressure sensitive tape.
9. With the aid of an assistant, install axle shaft (15) in rear axle housing (1). Remove pressure sensitive tape.

9-3. REAR AXLE HOUSING, SHAFTS, SEALS, BEARINGS, AND PLANETARY PINION CARRIER MAINTENANCE (Con't).

WARNING

Hot oil gives off highly flammable fumes. When heating parts in oil, do not smoke or allow open flame nearby. Make sure area is well-ventilated. Heat parts only in tank with lid which can be closed quickly to extinguish fire. Wear eye protection, protective gloves and clothing when heating parts in oil and handling hot parts. Hot oil and hot

CAUTION

Do not heat tapered cone and rollers over 300°F (149°C). If overheated, temper of bearing will be affected, causing tapered cone and rollers failure.

10. Using oil heating equipment, heat tapered cone and rollers (43) in oil. When hot, position tapered cone and rollers in place on axle shaft (15).

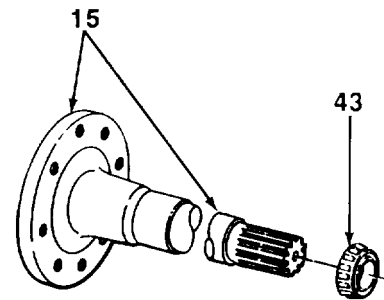

11. Using retaining ring pliers, position retaining ring (36) in place on planetary pinion carrier (32).

NOTE

There are 23 roller bearings for each planetary pinion.

12. Using grease to hold them in place, install 69 roller bearings (27) in three spur gears (26).
 13. Install three spur gears (26) with assembled parts and six thrust washer bearings (25) in planetary pinion carrier (32).

CAUTION

Ensure that roller bearings do not fall out of place. Roller bearings will bend when planetary pinion shafts are installed. Install planetary pinion shafts slowly to prevent bends to roller bearings.

14. Install three planetary pinion shafts (28) in planetary pinion carrier (32) and three spur gears (26) with assembled parts until ends of planetary pinion shafts contact retaining ring (36).
 15. Using retaining ring pliers, squeeze retaining ring (36) together and slide three planetary pinion shafts (28) in all the way. Release retaining ring and lock in slots of each planetary pinion shaft.

TA701446

9-3. REAR AXLE HOUSING, SHAFTS, SEALS, BEARINGS, AND PLANETARY PINION CARRIER MAINTENANCE (Con't).

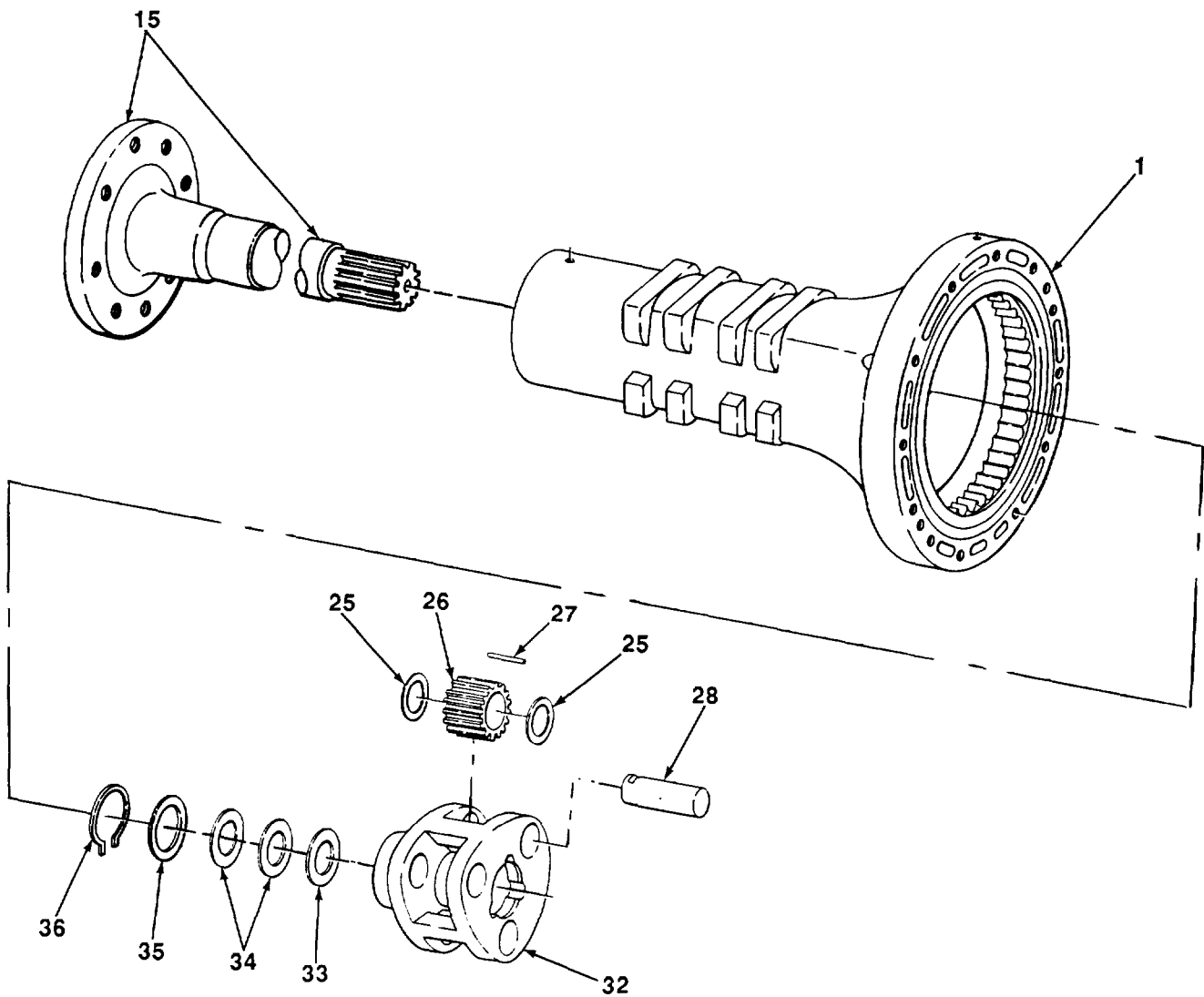

16. Install thrust washer bearing (35) and planetary pinion carrier (32) with assembled parts in rear axle housing (1) and on axle shaft (15).
17. Place 1/2 in. (13 mm) piece of 1/3 In. (3 mm) solid tin alloy solder on end of axle shaft (15) and planetary pinion carrier (32) and hold in place with grease.
18. Install shims (34) and spacer (33) on axle shaft (15) and planetary pinion carrier (32).

TA701447

9-3. REAR AXLE HOUSING, SHAFTS, SEALS, BEARINGS, AND PLANETARY PINION CARRIER MAINTENANCE (Con't).

CAUTION

- Do not torque screw to more than 55 lb.-ft. (75 N•m) during bearing preload adjustment or damage to bearings will result.
- Axle shaft must be turned while screw is being tightened, or damage to bearings will result.

19. Install, but do not tighten screw (30) in washer (31) and axle shaft (15).

NOTE

For loader backhoes with serial numbers 235786-235999, use $\frac{9}{16}$ in. -12 UNC x 5 in. screws. For loader backhoes with serial numbers 319995-342573, use $\frac{3}{4}$ in. -10 UNC X 5 in. screws.

20. Install two screws (45) opposite each other in axle housing (1) flange so that 2 in. (5.1 cm) of each screw extends out of flange.

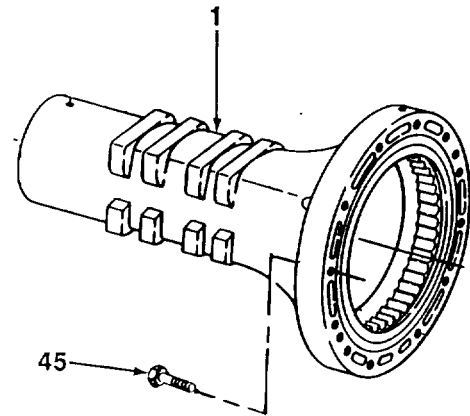

21. While assistant turns axle shaft (15) clockwise, use pinch bar and two screws (45) to tighten screw (30). Torque screw to 55 lb.-ft. (75 N•m).

22. While assistant holds axle shaft (15) from turning, remove screw (30), washer (31), spacer (33), and $\frac{1}{2}$ in. (13 mm) piece of solid tin alloy solder.

23. Using micrometer caliper set, measure thickness across flats pressed in X in. (13 mm) piece of solid tin alloy solder. Subtract 0.005 in. (0.127 mm) from thickness.

24. Add or remove shims (34) from shim pack until thickness of shims is the same as thickness in step 23.

25. Install shims (34), spacer (33), and washer (31) on axle shaft (15) and planetary pinion carrier (32).

CAUTION

Axle shaft must be turned while screw is being tightened, or damage to bearings will result.

26. Install, but do not tighten screw (30) in washer (31) and axle shaft (15).

27. While assistant turns axle shaft (15) clockwise, use pinch bar and two screws (45) to tighten screw (30). Torque screw to 180-240 lb.-ft. (244-325 N•m).

28. Using torque wrench, turn axle shaft (15) by screw (30) three full turns. While turning axle shaft, check bearing preload on torque wrench. Preload should be 8-12 lb.-ft. (11-16 N•m).

NOTE

If bearing preload was within specification in step 28, skip steps 29 and 30.

29. While assistant holds axle shaft (15) from turning, remove screw (30) and washer (31).

9-3. REAR AXLE HOUSING, SHAFTS, SEALS, BEARINGS, AND PLANETARY PINION CARRIER MAINTENANCE (Con't).

30. If preload was too great, remove one 0.005 in. (127 mm) shim (34). If preload was too little, add one 0.005 in. (127 mm) shim. Repeat steps 26 through 29.
31. Install lockplate (29) on screw (30) and planetary pinion carrier (32). Tighten screw as required to seat lockplate.
32. Install connector (17) and new preformed packing (18) in rear axle housing (1).
33. Install new grease fitting (16) in rear axle housing (1).
34. Install connector (22) and new preformed packing (21) in rear axle housing (1).

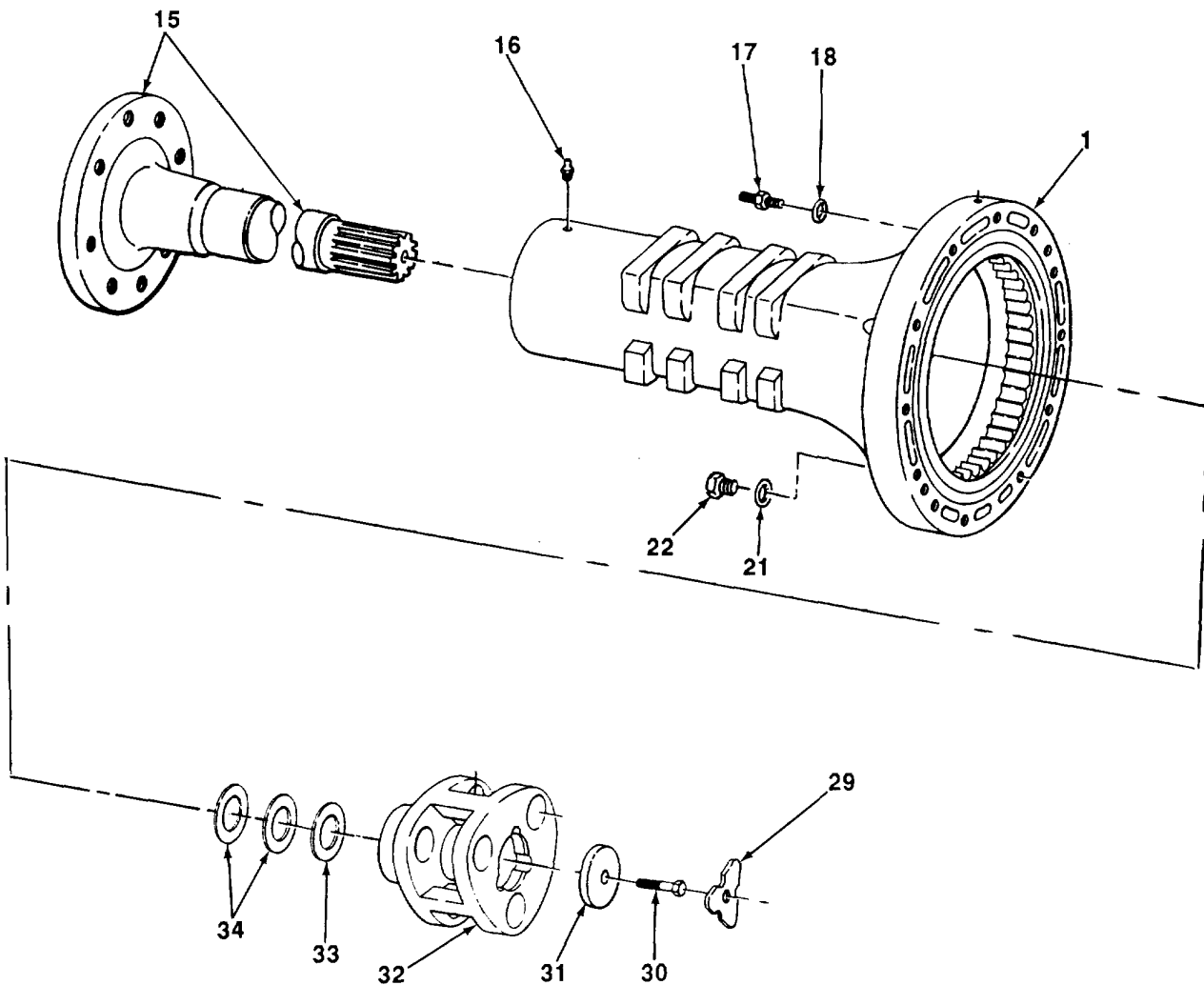

TA701449

9-3. REAR AXLE HOUSING, SHAFTS, SEALS, BEARINGS, AND PLANETARY PINION CARRIER MAINTENANCE (Con't).

35. Install elbow (24) and new preformed packing (23) in connector (22).
36. Install hydraulic bleeder valve (20) and cap (19) in rear axle housing (1). Press cap closed on hydraulic bleeder valve.

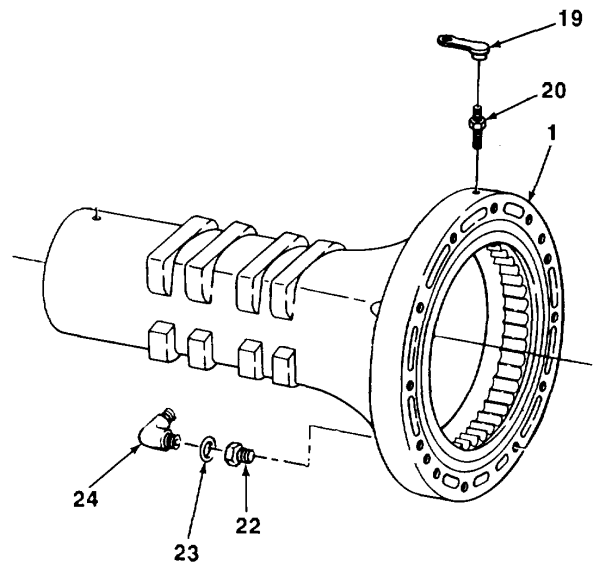

f. INSTALLATION

WARNING

Use extreme caution when handling heavy parts. Lifting device is required when parts weigh over 50 lb (23 kg) for a single person lift, over 100 lb (45 kg) for a two person lift, and over 150 lb (68 kg) for a three or more person lift. Keep clear of heavy parts supported only by lifting device. Failure to follow this warning may cause serious injury or death to personnel.

1. Install two new preformed packings (13 and 14) or brake pressure plate (12). Coat preformed packings with grease.
2. Install brake pressure plate (12) with assembled parts in rear axle housing (1).

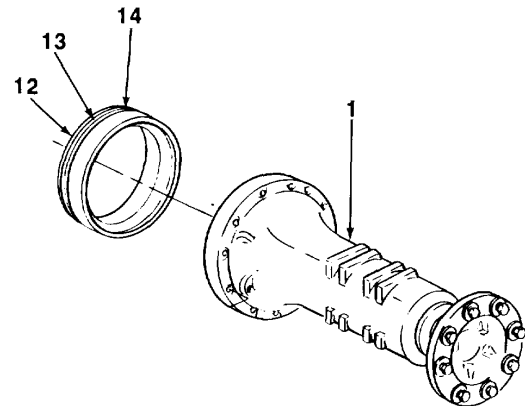

9-3. REAR AXLE HOUSING, SHAFTS, SEALS, BEARINGS, AND PLANETARY PINION CARRIER MAINTENANCE (Con't).

NOTE

Steps 3 through 7 apply only to left side rear axle housing.

- 3. Aline match-marks and install brake disk (8) on final drive shaft (7).
- 4. Aline splines and install final drive shaft (7) and assembled brake disk (8) in collar (11) and transmission (9).

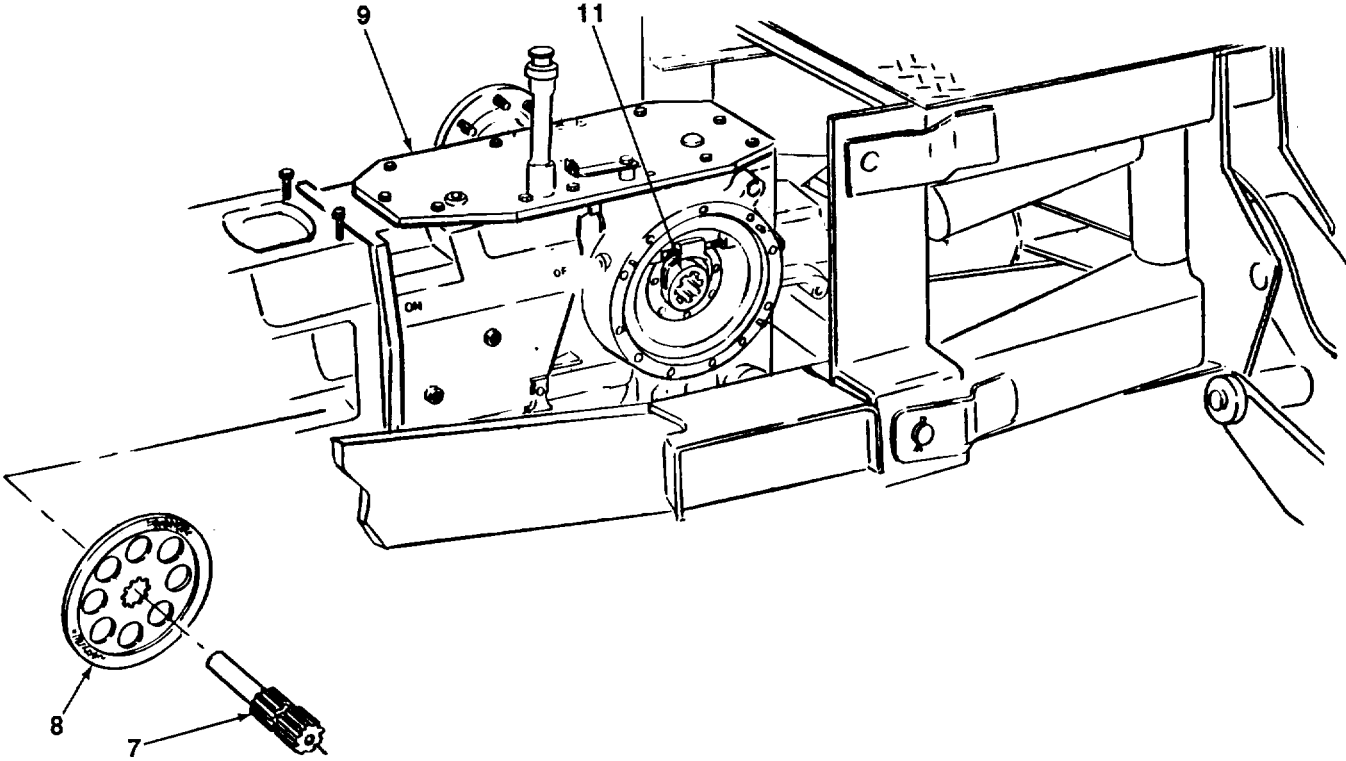

TA701451

LEFT SIDE REAR AXLE HOUSING

9-3. REAR AXLE HOUSING, SHAFTS, SEALS, BEARINGS, AND PLANETARY PINION CARRIER MAINTENANCE (Con't).

- 5. Using lifting device, raise and align rear axle housing (1) with final drive shaft (7); align three straight pins (44) with holes in transmission (9).
- 6. Install rear axle housing (1) with assembled parts and new gasket (6) on transmission (9). Turn axle shaft (15) as required to mesh final drive shaft (7) in rear axle housing.
- 7. Install twelve screws (10) in rear axle housing (1) and transmission (9). Alternately torque screws to 85 lb.-ft. (115 N•m).

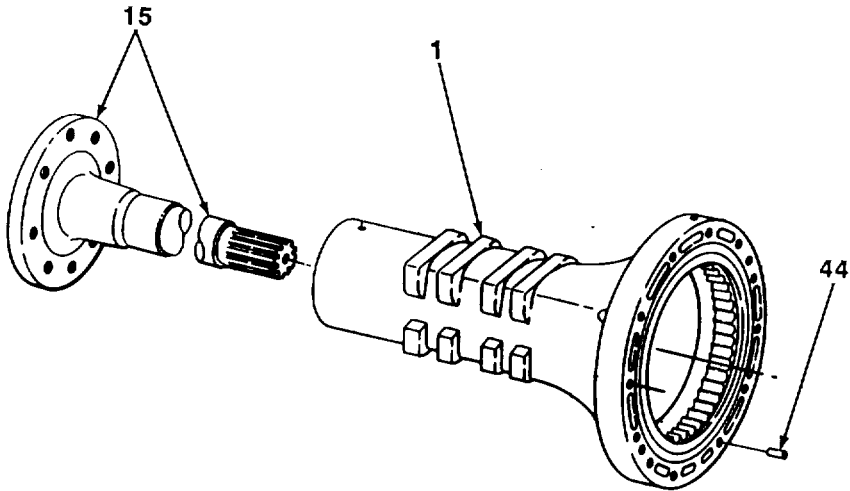

TA701452

9-3. REAR AXLE HOUSING, SHAFTS, SEALS, BEARINGS, AND PLANETARY PINION CARRIER MAINTENANCE (Con't).

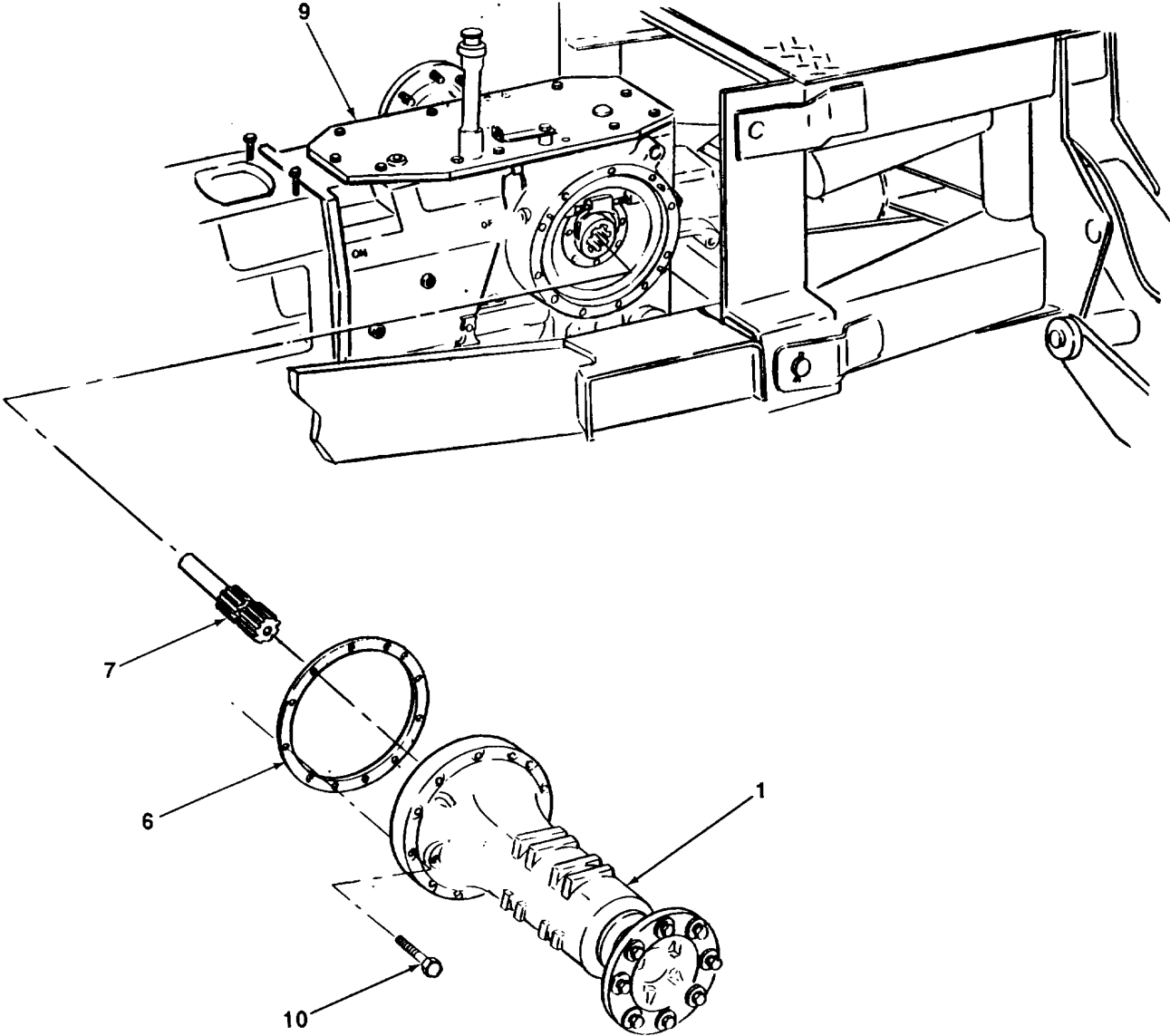

TA701453

LEFT SIDE REAR AXLE HOUSING

9-3. REAR AXLE HOUSING, SHAFTS, SEALS, BEARINGS, AND PLANETARY PINION CARRIER MAINTENANCE (Con't).

NOTE

Steps 8 through 12 apply only to right side rear axle housing.

8. Aline match-marks and Install brake disk (8) on final drive shaft (7).
9. Aline splines and install final drive shaft (7) and assembled brake disk (8) in drive shaft hub and transmission (9).
10. Using lifting device, raise and aline rear axle housing (1) with final drive shaft (7); aline three straight pins (44) with holes in transmission (9).
11. Install rear axle housing (1) with assembled parts and new gasket (6) on transmission (9). Turn axle shaft (15) as required to mesh final drive shaft (7) in rear axle housing.

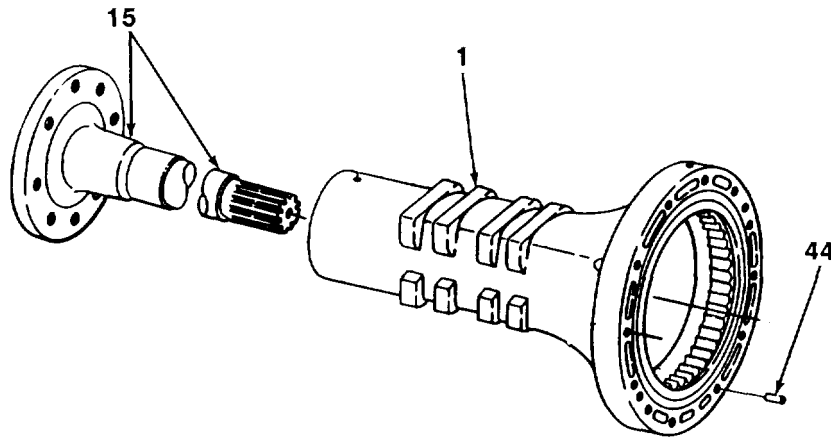

12. Install, but do not tighten, eight screws (10) in rear axle housing (1) and transmission (9).
13. Remove wood blocks from under transmission (9).

TA701454

9-3. REAR AXLE HOUSING, SHAFTS, SEALS, BEARINGS, AND PLANETARY PINION CARRIER MAINTENANCE (Con't).

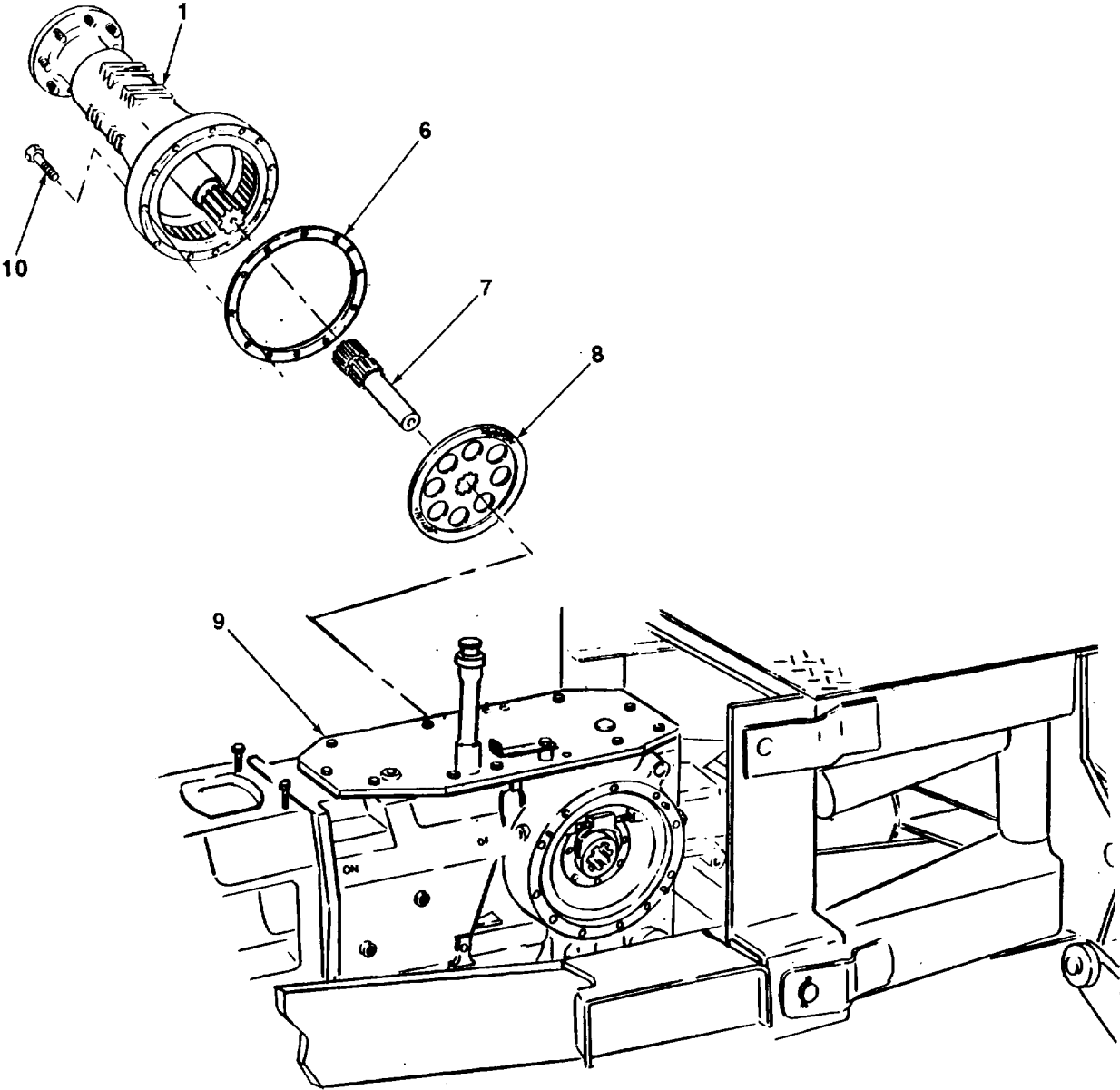

RIGHT SIDE REAR AXLE HOUSING

TA701455

9-3. REAR AXLE HOUSING, SHAFTS, SEALS, BEARINGS, AND PLANETARY PINION CARRIER MAINTENANCE (Con't).

- 14. Install brake oil line (5) on elbow (4).
- 15. Install connector (2) on brake light switch terminal (3).

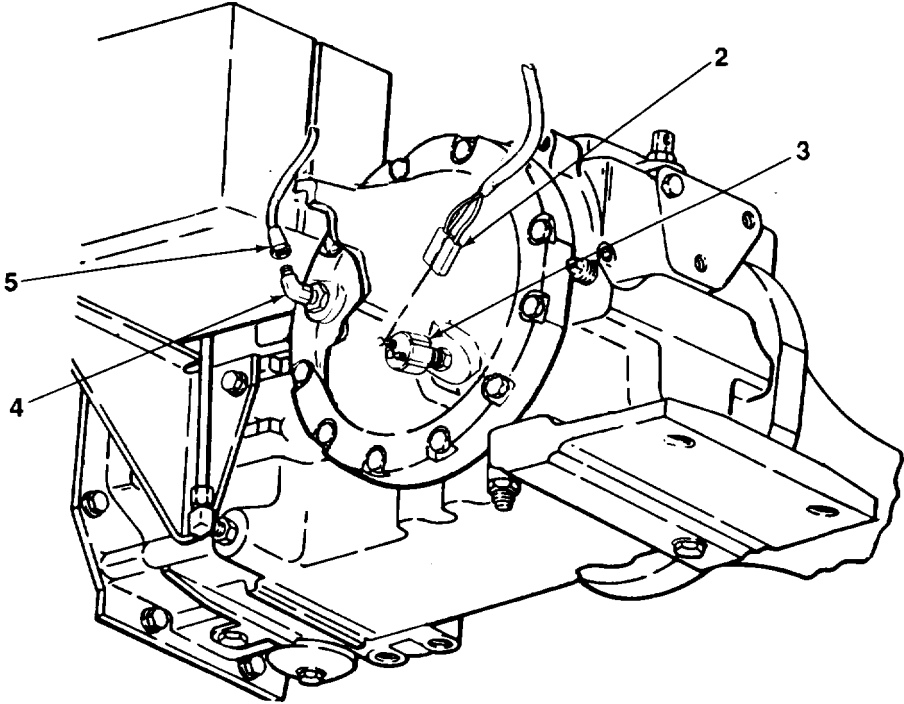

TA701456

**CHAPTER 10
BRAKE SYSTEM MAINTENANCE**

Paragraph Number	Paragraph Title	Page Number
10-1	Parking Brake Band and Lining Maintenance.....	10-1
10-2	Parking Brake Linkage Maintenance	10-6
10-3	Service Brake Disk and Pressure Plate Repair	10-13
10-4	Hydraulic Brake Cylinder Maintenance.....	10-20

10-1. PARKING BRAKE BAND AND LINING MAINTENANCE.

This Task Covers:

- | | |
|--|--|
| <ul style="list-style-type: none"> a. Removal b. Disassembly c. Cleaning and Inspection | <ul style="list-style-type: none"> d. Assembly e. Installation |
|--|--|

Initial Setup:

Equipment Conditions:

- Transmission drained (see TM 5-2420-222-20).
- Transmission top cover removed (see paragraph 8-12 or 8-13).

Tools/Test Equipment:

- General mechanic's tool kit
- Field automotive shop set

References:

- LO5-2420-222-12
- TM 5-2420-222-10
- TM 5-2420-222-20

Materials/Parts:

- Rags (Item 28, Appendix B)
- Dry cleaning solvent (Item 31, Appendix B)
- One cotter pin
- One preformed packing

General Safety Instructions:

- Dry cleaning solvent is flammable and must not be used near open flame. Use only in a well-ventilated area.

10-1. PARKING BRAKE BAND AND LINING MAINTENANCE (Con't).**a. REMOVAL****WARNING**

Ensure that loader bucket and backhoe bucket are lowered to ground and wheels are blocked to prevent loader backhoe from moving while performing maintenance on parking brake.

1. Release parking brake lever (see TM 5-2420-222-10).
2. Disconnect auger bleed line (6) from elbow (5). Remove elbow and adapter (7) from transmission (9).
3. Remove special capscrew (8) from brake band and lining (1) and shouldered pin (12).
4. Loosen nut (14) and remove special screw (16) and preformed packing (15) from transmission (9). Discard preformed packing. Remove nut from special screw.
5. Remove cotter pin (19), straight pin (10), and washer (13) from anchor band (11) and brake band and lining (1). Discard cotter pin.
6. Remove spring (2) from grooved pin (4) and spring pin (3).
7. Spread and rotate brake band and lining (1) out of parking brake drum (17) and anchor band (11).

b. DISASSEMBLY**CAUTION**

Do not remove linings from brake band unless damaged. Removal will damage parts.

Using electric drill and twist drill set, remove 12 rivets (21) and four linings (22) from brake band (20).

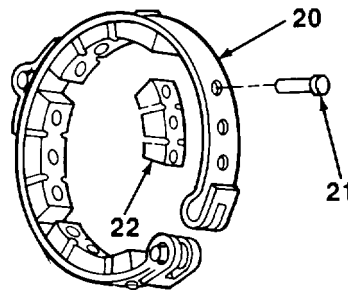

TA701457

10-1. PARKING BRAKE BAND AND LINING MAINTENANCE (Con't).

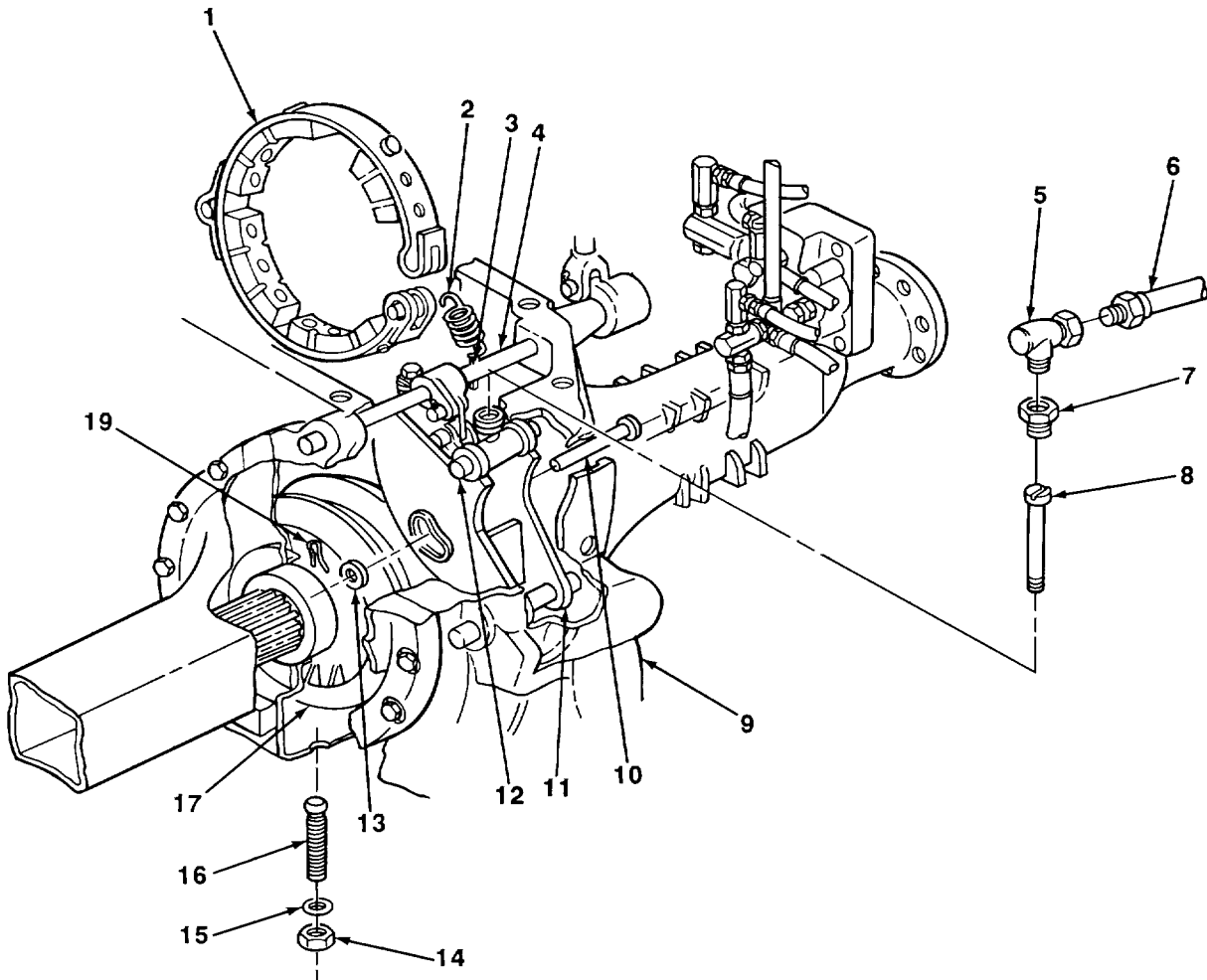

c. CLEANING AND INSPECTION

WARNING

Dry cleaning solvent, P-D-680, is toxic and flammable. Always wear protective goggles and gloves, and use only in a well-ventilated area. Avoid contact with skin, eyes, and clothes, and DO NOT breathe vapors. DO NOT use near open flame or excessive heat. The solvent's flash point is 1000F-138°F (38°C-59°C). If you become dizzy while using cleaning solvent, Immediately get fresh air and medical help. If solvent contacts eyes, Immediately wash your eyes and get medical aid.

1. Clean brake band and all other metal parts with dry cleaning solvent and clean rags. Dry thoroughly with clean, dry rags.
2. Inspect brake band and all other metal parts for cracks, breaks, and abnormal bends.
3. Inspect linings for cracks, chips, glazing, and excessive wear. Linings should not be worn down to rivets.

TA701458

10-1. PARKING BRAKE BAND AND LINING MAINTENANCE (Con't).**d. ASSEMBLY****NOTE**

**Perform steps 1 and 2
only if linings were
removed.**

1. Position four linings (22) and 12 rivets (21) in place on brake band (20).
2. Using brake and clutch reliner, peen ends of rivets (21) over to secure linings (22).

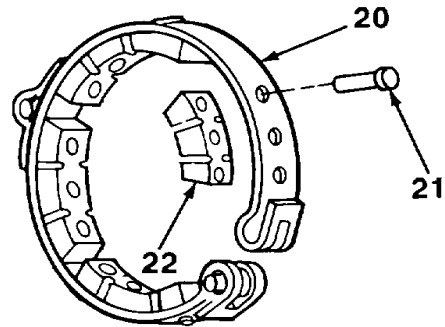
**e. INSTALLATION**

1. Spread ends of brake band and lining (1) and rotate into position on parking brake drum (17) and anchor band (11).
2. Install spring (2) on grooved pin (4) and spring pin (3) in shouldered pin (12).
3. Install straight pin (10) and washer (13) in anchor band (11) and brake band and lining (1). Install new cotter pin (19) in straight pin.
4. Install special capscrew (8) partway in brake band and lining (1) and shouldered pin (12).
5. Install special screw (16) partway in transmission (9). Install new preformed packing (15) in place on special screw and transmission.
6. Install nut (14) partway on special screw (16).
7. Install elbow (5) and adapter (7) in transmission (9). Connect auger bleed line (6) to elbow.
8. Set and release parking brake lever five times to seat linkage (see TM 5-2420-222-10).
9. Adjust parking brake (see TM 5-2420-222-20).
10. Set parking brake lever (see TM 5-2420-222-10).
11. Install transmission top cover (see paragraph 8-12 or 8-13).
12. Fill transmission (see LO 5-2420-222-12).

NOTE

Steps 13 through 21 apply only if new linings were installed.

13. Ensure that front wheels are straight ahead. Block front wheels.
14. Using hydraulic floor jack, raise left side rear axle housing (18) until tire is off ground, then support with jackstand and remove hydraulic floor jack.

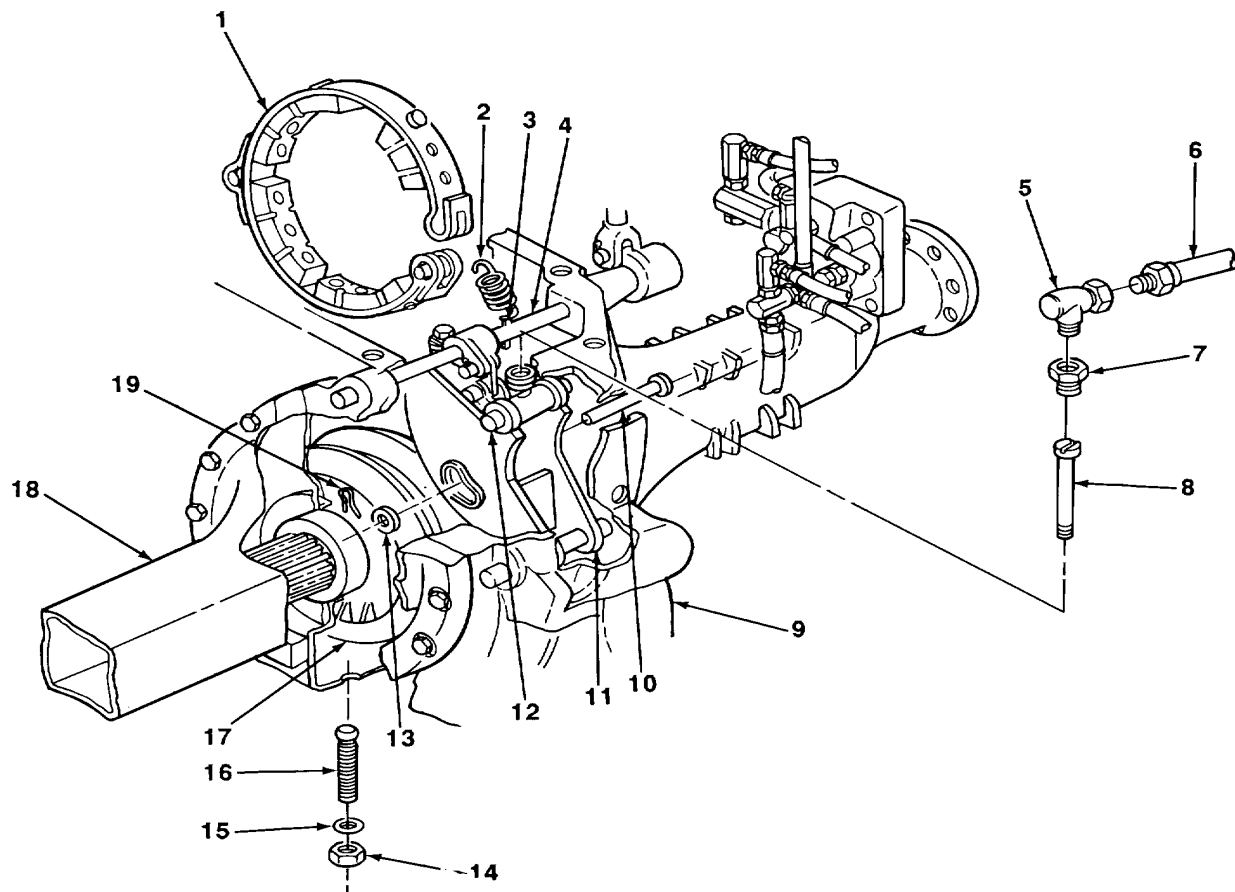
10-1. PARKING BRAKE BAND AND LINING MAINTENANCE (Con't).**WARNING**

Ensure that differential lock is not engaged before burnishing parking brake linings (see TM 5-2420-222-10). If differential lock is engaged, loader backhoe will run off Jackstand and can cause serious Injury or death to personnel.

15. Start engine assembly and run at 1500 rpm (see TM 5-2420-222-10).
16. Place transmission in fourth gear (see TM 5-2420-222-10).
17. Engage clutch for 20-25 seconds to burnish parking brake linings (see TM 5-2420-222-10).
18. Shut down engine assembly (see TM 5-2420-222-10).
19. Using hydraulic floor jack, raise left side rear axle housing (18) and remove jackstand. Lower and remove hydraulic floor jack.
20. Unblock front wheels.
21. Adjust parking brake (see TM 5-2420-222-20).

TA701460

10-2. PARKING BRAKE LINKAGE MAINTENANCE.*This Task Covers:*

- | | |
|----------------------------|-----------------|
| a. Removal | d. Repair |
| b. Disassembly | e. Assembly |
| c. Cleaning and Inspection | f. Installation |

*Initial Setup:***Equipment Conditions:**

- Parking brake band and lining removed (see paragraph 10-1).

Tools/Test Equipment:

- General mechanic's tool kit
- Field automotive shop set

Materials/Parts:

- Rags (Item 28, Appendix B)
- Dry cleaning solvent (Item 31, Appendix B)
- One preformed packing
- One washer
- Two spring pins
- Four cotter pins

General Safety Instructions:

- Dry cleaning solvent is flammable and must not be used near open flame. Use only in a well-ventilated area.

a. REMOVAL**NOTE**

If brake shouldered shaft does not have to be removed, skip steps 1 through 9.

1. Remove backhoe main frame (see paragraph 15-4).

NOTE

Loader backhoes with serial numbers 235786-235999 have a canopy. Loader backhoes with serial numbers 319995-342573 have a roll-over protective structure (ROPS).

2. Remove roll-over protective structure or canopy right rear support and mounts (see paragraph 13-4).
3. Remove cotter pin (1) and straight pin (3) from brake rod (2) and support arm (4). Discard cotter pin.

NOTE

Use a drain pan to catch fluid when disconnecting hose. Clean up all spills.

4. Remove elbow (8) and hose (7) from tee (9).
5. Drive spring pin (5) out of shouldered shaft (6). Discard spring pin.

10-2. PARKING BRAKE LINKAGE MAINTENANCE (Con't).

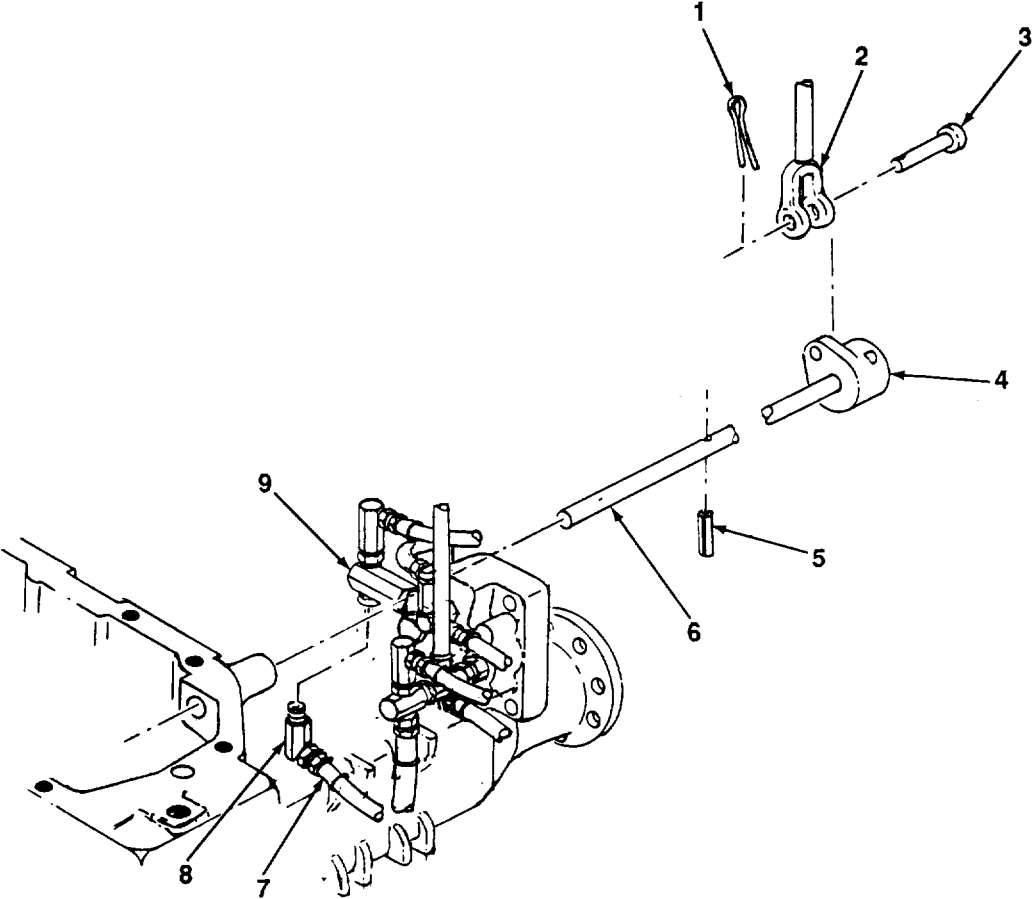

TA701461

10-2. PARKING BRAKE LINKAGE MAINTENANCE (Con't).

6. Remove cotter pin (24) and straight pin (17) from remote control lever (15) and connecting link (16). Discard cotter pin.
7. Bend tab of washer (14) away from head of capscrew (13). Remove capscrew and washer from remote control lever (15). Discard washer.
8. Remove woodruff key (11) and remote control lever (15) from shouldered shaft (6). Remove shouldered shaft from transmission (26).
9. Remove preformed packing (10) from shouldered shaft (6). Discard preformed packing.

NOTE

**Brake band arm is used on loader backhoes with serial numbers 319995-342573.
Brake bellcrank is used on loader backhoes with serial numbers 235786-235999.**

10. Remove brake band arm (20) or brake bellcrank (21) with assembled parts out of anchor band (22).
11. Remove pipe plug (28) from transmission (26).
12. Remove cotter pin (29) from grooved pin (27). Hold anchor band (22) and slide grooved pin out of transmission (26). Discard cotter pin.
13. Remove anchor band (22) and assembled grooved pin (25) out of transmission (26). Remove grooved pin from anchor band.

b. DISASSEMBLY**NOTE**

Step 1 applies only to loader backhoes with serial numbers 235786-235999.

1. Remove shouldered pin (19) from brake bellcrank (21).

NOTE

**Brake band arm is used on loader backhoes with serial numbers 319995-342573.
Brake bellcrank is used on loader backhoes with serial numbers 235786-235999.**

2. Remove cotter pin (23), straight pin (18), and connecting link (16) from brake band arm (20) or brake bellcrank
3. Position shouldered shaft (6) and support arm (4) in vise with caps. Match-mark support arm to shouldered
4. Drive spring pin (12) out of support arm (4) and shouldered shaft (6). Remove support arm from shouldered shaft. Discard spring pin.

c. CLEANING AND INSPECTION**WARNING**

Dry cleaning solvent, P-D-680, is toxic and flammable. Always wear protective goggles and gloves, and use only in a well-ventilated area. Avoid contact with skin, eyes, and clothes, and DO NOT breathe vapors. DO NOT use near open flame or excessive heat. The solvent's flash point is 100°F-138°F (380C-590C). If you become dizzy while using cleaning solvent, immediately get fresh air and medical help. If solvent contacts eyes, immediately wash your eyes and get medical aid.

1. Clean all metal parts with dry cleaning solvent and clean rags. Dry thoroughly with clean, dry rags.

10-2. PARKING BRAKE LINKAGE MAINTENANCE (Con't).

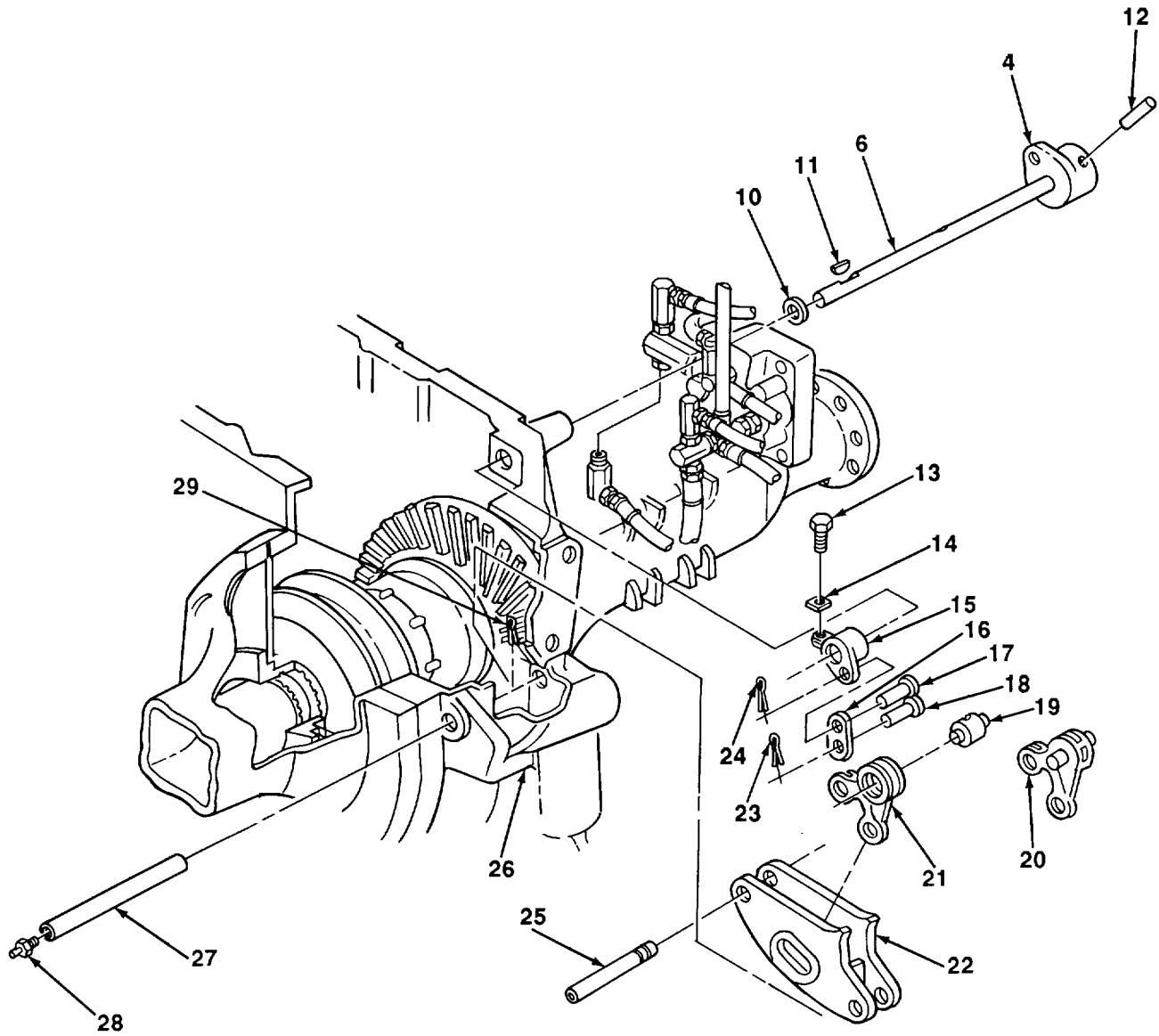

2. Inspect all metal parts for cracks, breaks, and abnormal bends.
3. Inspect remote control lever for damaged threads.
4. Inspect straight pins, shouldered shaft, grooved pins, and brake band arm for excessive wear or deep grooves.

TA701462

10-2. PARKING BRAKE LINKAGE MAINTENANCE (Con't).

d. REPAIR

Restore damaged remote control lever (15) threads using screw threading set.

e. ASSEMBLY

1. Aline match-marks and install support arm (4) on shouldered shaft (6). Drive new spring pin (12) in support arm and shouldered shaft.

NOTE

**Brake band arm is used on loader backhoes with serial numbers 319995-342573.
Brake bellcrank is used on loader backhoes with serial numbers 235786-235999.**

2. Install connecting link (16), straight pin (18), and new cotter pin (23) in brake band arm (20) or brake bellcrank (21).

NOTE

Step 3 applies only to loader backhoes with serial numbers 235786-235999.

3. Install shouldered pin (19) in brake bellcrank (21).

f. INSTALLATION

1. Install grooved pin (25) in anchor band (22).
2. Position anchor band (22) and assembled grooved pin (25) in transmission (26). Hold anchor band and install grooved pin (27) in transmission.
3. Install new cotter pin (29) in grooved pin (27).
4. Install pipe plug (28) in transmission (26).

NOTE

**Brake band arm is used on loader backhoes with serial numbers 319995-342573.
Brake bellcrank is used on loader backhoes with serial numbers 235786-235999.**

5. Install brake bellcrank (21) or brake band arm (20) with assembled parts in place in anchor band (22).

NOTE

If brake shouldered shaft was not removed, skip steps 6 through 16.

6. Install new preformed packing (10) in place on shouldered shaft (6).
7. Slide shouldered shaft (6) partway in transmission (26) and install remote control lever (15) on shouldered shaft.
8. Install woodruff key (11) in shouldered shaft (6).
9. Aline keyway in remote control lever (15) with woodruff key (11) in shouldered shaft (6). Slide remote control lever in place on woodruff key.

10-2. PARKING BRAKE LINKAGE MAINTENANCE (Con't).

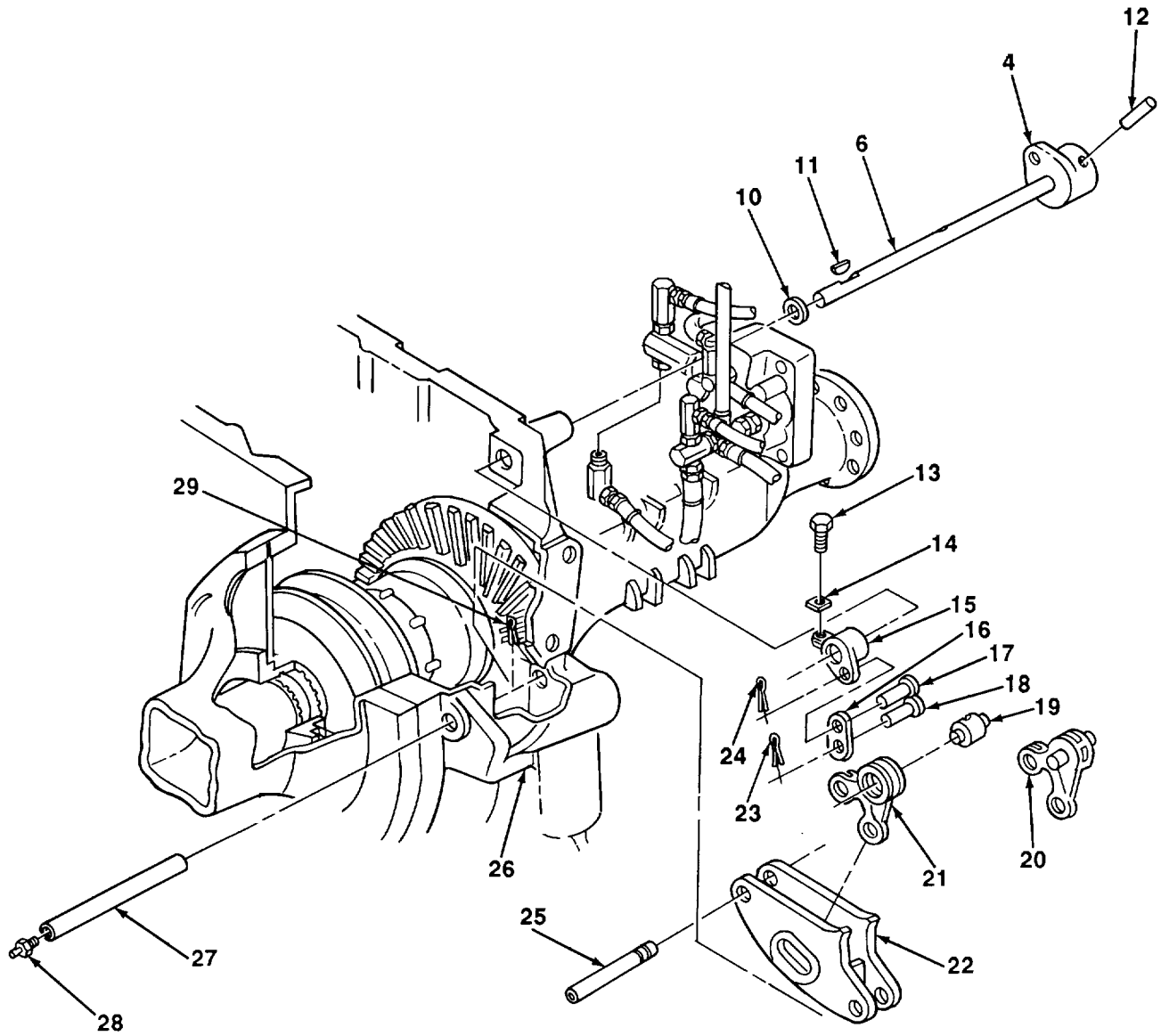

10. Install capscrew (13) and new washer (14) in remote control lever (15). Bend one tab of washer against flat of capscrew.
11. Aline connecting link (16) with remote control lever (15) and Install straight pin (17) and new cotter pin (24).

TA701463

10-2. PARKING BRAKE LINKAGE MAINTENANCE (Con't).**NOTE**

When installing spring pin in shouldered shaft, ensure that top end of spring pin is flush with top side of shouldered shaft. If not, spring pin will catch on transmission top cover preventing parking brake from working.

12. Drive new spring pin (5) in shouldered shaft (6) until flush with top side of shouldered shaft.
13. Install elbow (8) and hose (7) on tee (9).
14. Aline brake rod (92) with support arm (4) and install straight pin (3) and new cotter pin (1).

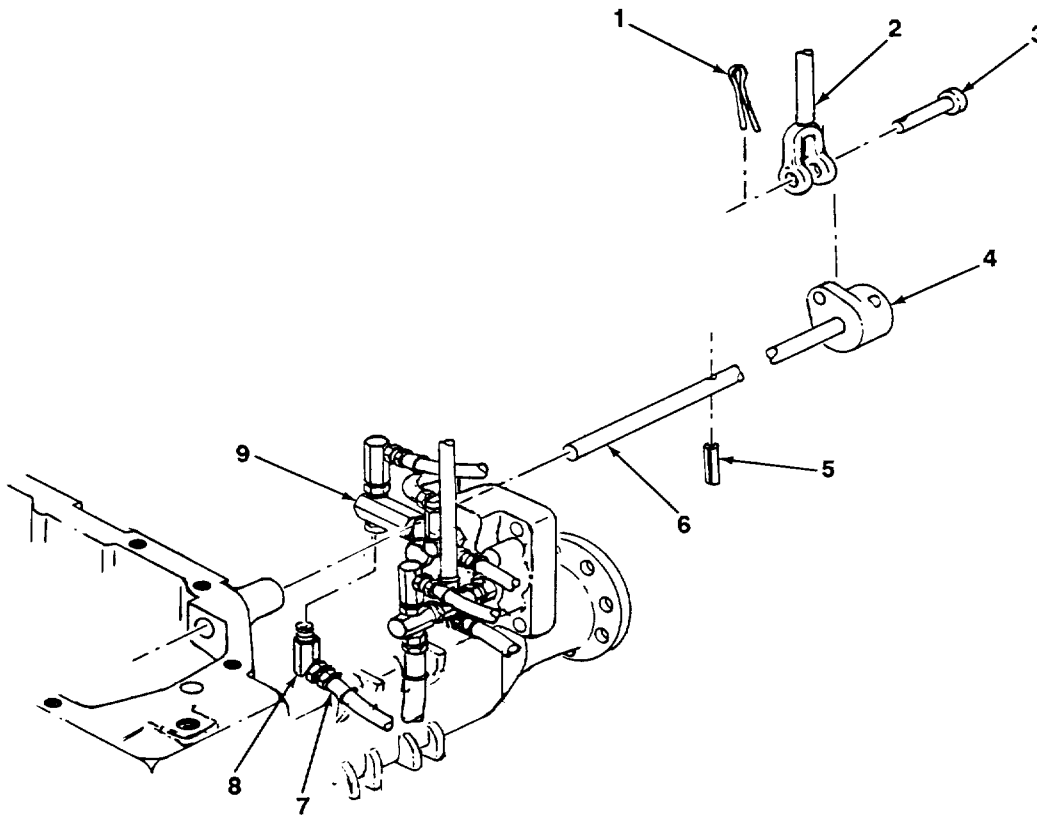
**NOTE**

Loader backhoes with serial numbers 235786-235999 have a canopy. Loader backhoes with serial numbers 319995-342573 have a roll-over protective structures (ROPS).

15. Install roll-over protective structure or canopy right rear support and mounts (see paragraph 13-4).
16. Install backhoe main frame (see paragraph 15-4).

FOLLOW-ON TASKS:

- Install parking brake band and lining (see paragraph 10-1).

10-3. SERVICE BRAKE DISK AND PRESSURE PLATE REPAIR.*This Task Covers:*

- | | |
|----------------------------|-----------|
| a. Cleaning and Inspection | b. Repair |
|----------------------------|-----------|

*Initial Setup:***Equipment Conditions:**

- Right or left rear axle housing removed (see paragraph 9-3).

Tools/Test Equipment:

- General mechanic's tool kit
- Field automotive shop set
- Cutting tool kit

References:

- LO 5-2420-222-12
- TM 5-2420-222-10

Materials/Parts:

- Rags (Item 28, Appendix B)
- Dry cleaning solvent (Item 31, Appendix B)
- One lockwasher

General Safety Instructions:

- Dry cleaning solvent is flammable and must not be used near open flame. Use only in a well-ventilated area.

NOTE

- Left and right brake disks and pressure plates are repaired the same way, except as noted. Repeat steps as required for other side.
- When performing repair on brake disk and pressure plate, both sides must be done or uneven braking will result.

a. CLEANING AND INSPECTION**WARNING**

Dry cleaning solvent, P-D-680, is toxic and flammable. Always wear protective goggles and gloves, and use only in a well-ventilated area. Avoid contact with skin, eyes, and clothes, and DO NOT breathe vapors. DO NOT use near open flame or excessive heat. The solvent's flash point is 1000F-1380F (38°C-590C). If you become dizzy while using cleaning solvent, immediately get fresh air and medical help. If solvent contacts eyes, immediately wash your eyes and get medical aid.

1. Clean all metal parts with dry cleaning solvent and clean rags. Dry thoroughly with clean, dry rags.

10-3. SERVICE BRAKE DISK AND PRESSURE PLATE REPAIR (Con't).

2. Clean transmission braking surface (20) with rags and dry cleaning solvent. Dry thoroughly with clean, dry rags.
3. Inspect packing retainer (18) for scoring, heat cracks, excess wear, and discoloration.
4. Inspect brake disk (17) for worn, broken, or scored linings.
5. Inspect transmission braking surface (20) for scoring, heat cracks, and discoloration.
6. Using combination square and micrometer depth gage, measure distance from machined face of transmission (14) to transmission braking surface (20) or bottom of deepest score in transmission braking surface.
7. Distance recorded in step 6 must not exceed 1.210 in. (30.734 mm). If distance exceeds specification, remove, disassemble, and replace transmission housing (see paragraph 8-2).

b. REPAIR**NOTE**

- **Transmission braking surface may be resurfaced using the following steps.**
- **Use a drain pan to catch fluid when disconnecting oil line. Clean up all spills.**

1. Position drain pan under tee (1) and oil line (4). Disconnect oil line from tee.
2. Remove screw (7), washer (8), nut (10), and clamp (9) from oil lines (4, 12, and 13) and plate spacer (11).
3. Remove capscrew (2), lockwasher (3), plate spacer (11), and nut (6) from clamp angle bracket (5) and oil lines (4, 12, and 13). Discard lockwasher.
4. Plug oil line (4) and tee (1).
5. Plug oil line (15) and bleed passage (19) in transmission (14).

CAUTION

Keep grinding dust out of transmission to prevent damage to transmission, transmission oil pump, and hydraulic pump.

NOTE

Steps 6 through 8 apply only to left transmission braking surface.

6. Using rotary electric grinder and abrasive wheel, grind down differential lock shaft bosses (16) below face of transmission braking surface (20).

WARNING

Dry cleaning solvent, P-D-680, is toxic and flammable. Always wear protective goggles and gloves, and use only in a well-ventilated area. Avoid contact with skin, eyes, and clothes, and DO NOT breathe vapors. DO NOT use near open flame or excessive heat. The solvent's flash point is 100°F-138°F (380C-590C). If you become dizzy while using cleaning solvent, immediately get fresh air and medical help. If solvent contacts eyes, immediately wash your eyes and get medical aid.

7. Clean transmission braking surface (20) with dry cleaning solvent and rags. Dry thoroughly with clean, dry rags.

10-3. SERVICE BRAKE DISK AND PRESSURE PLATE REPAIR (Con't).

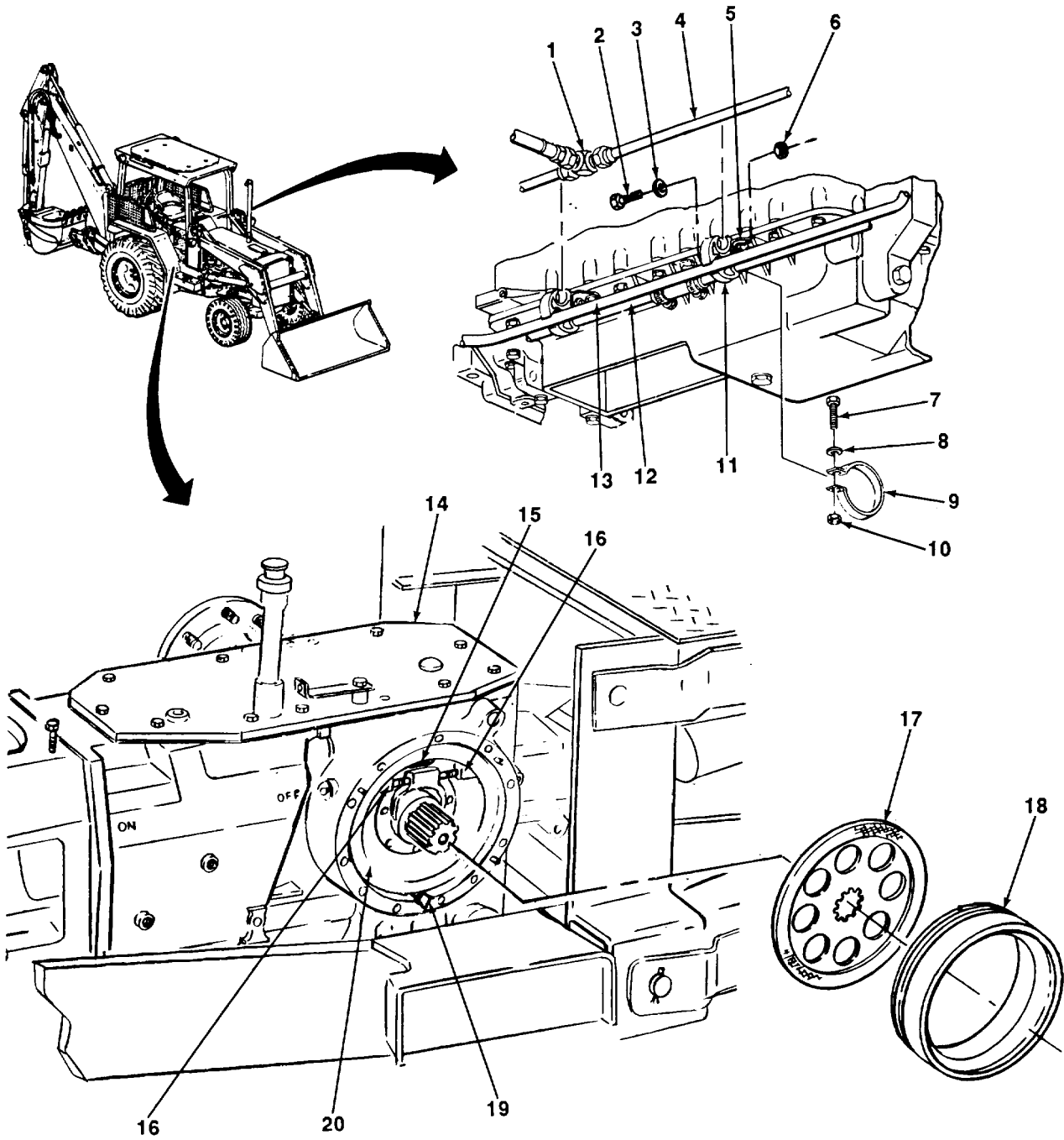

TA701465

10-3. SERVICE BRAKE DISK AND PRESSURE PLATE REPAIR (Con't).

8. Install final drive shaft (22) through collar (27), drive shaft hub (21), and differential bevel gear (23).

NOTE

Step 9 applies only to right transmission braking surface.

9. Install final drive shaft (25) in drive shaft hub (26) and differential bevel gear (24).
10.

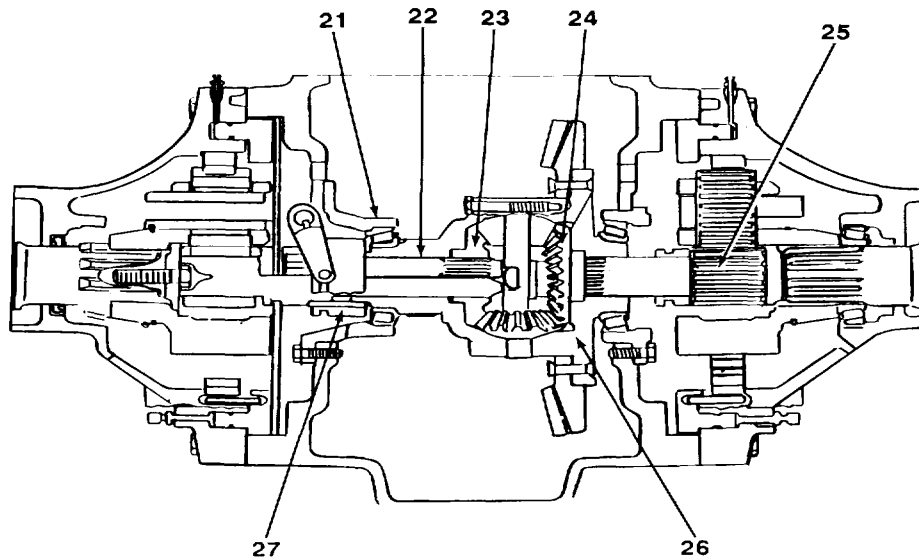

10. Install tool holder and assembled cutting blades on final drive shaft (22 or 25) with cutting blades facing transmission braking surface (20).
11. Position packing retainer (18) onto tool holder so that holes align with transmission (14).
12. Using key and combination square, install six socket head capscrews, washers, and R26125 valve springs in packing retainer (18) and transmission (14) until washers are 1A in. (3.81 cm) from surface of brake disk (17).
13. Check transmission fluid level (see LO 5-2420-222-12).
14. Start engine assembly (see TM 5-2420-222-10).
15. Engage differential lock and shift transmission into fourth gear (see TM 5-2420-222-10).

NOTE

Step 16 applies only to right transmission braking surface.

16. Shift reverser into reverse, engage clutch, and accelerate engine enough to prevent stalling (see TM 5-2420-222-10). Operate for one minute.
17. Shut down engine assembly (see TM 5-2420-222-10).
18. Using key, remove six socket head capscrews, washers, and valve springs from packing retainer (18) and transmission (14).

TA701466

10-3. SERVICE BRAKE DISK AND PRESSURE PLATE REPAIR (Con't).

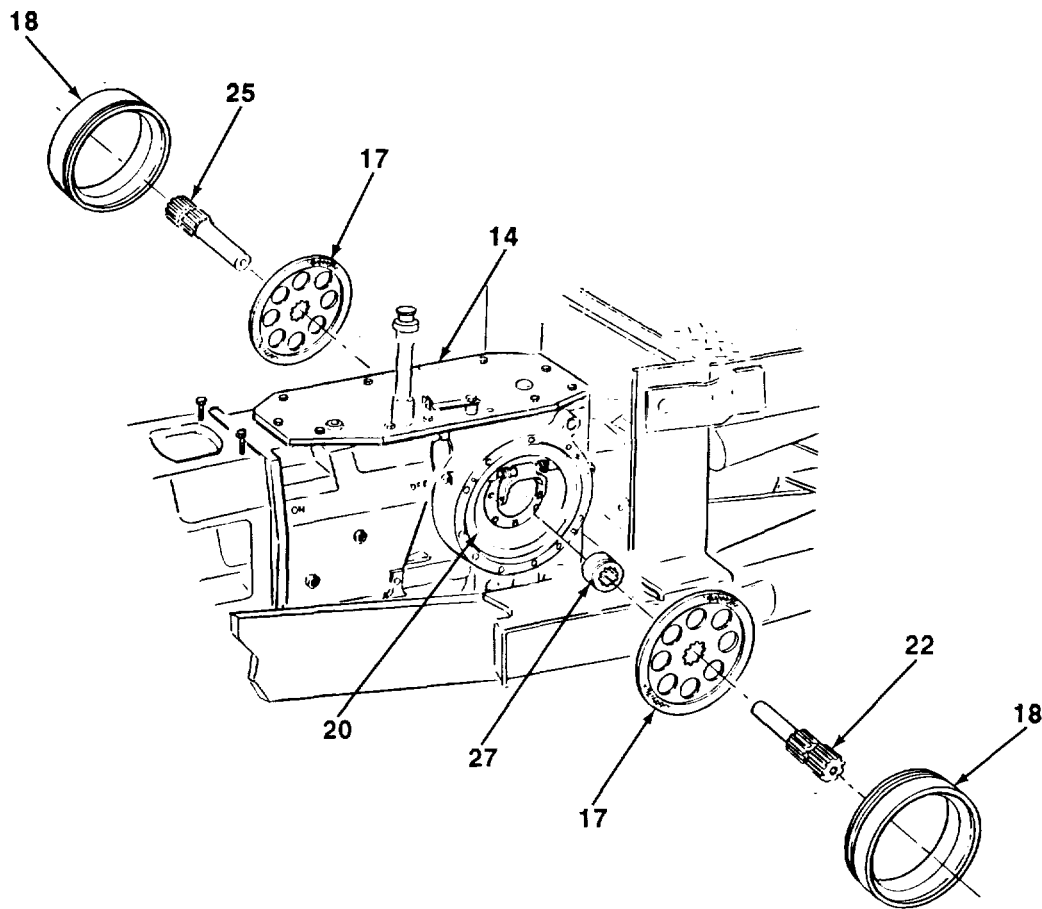

19. Remove packing retainer (18) and tool holder from transmission (14).
20. Inspect transmission braking surface (20) for scores. All score marks should be removed. If score marks remain, repeat steps 11 through 20.
21. Using combination square and micrometer depth gage, measure distance from machined surface of transmission (14) to transmission braking surface (20).
22. Distance recorded in step 21 must not exceed 1.210 in. (30.734 mm). If distance exceeds specification, remove, disassemble, and replace transmission housing (see paragraph 8-2).

NOTE

Step 23 applies only to left transmission braking surface.

23. Remove final drive shaft (22) from collar (27), drive shaft hub (21), and differential bevel gear (23).

NOTE

Step 24 applies only to right transmission braking surface.

24. Remove final drive shaft (25) from drive shaft hub (26) and differential bevel gear (24).

10-3. SERVICE BRAKE DISK AND PRESSURE PLATE REPAIR (Con't).

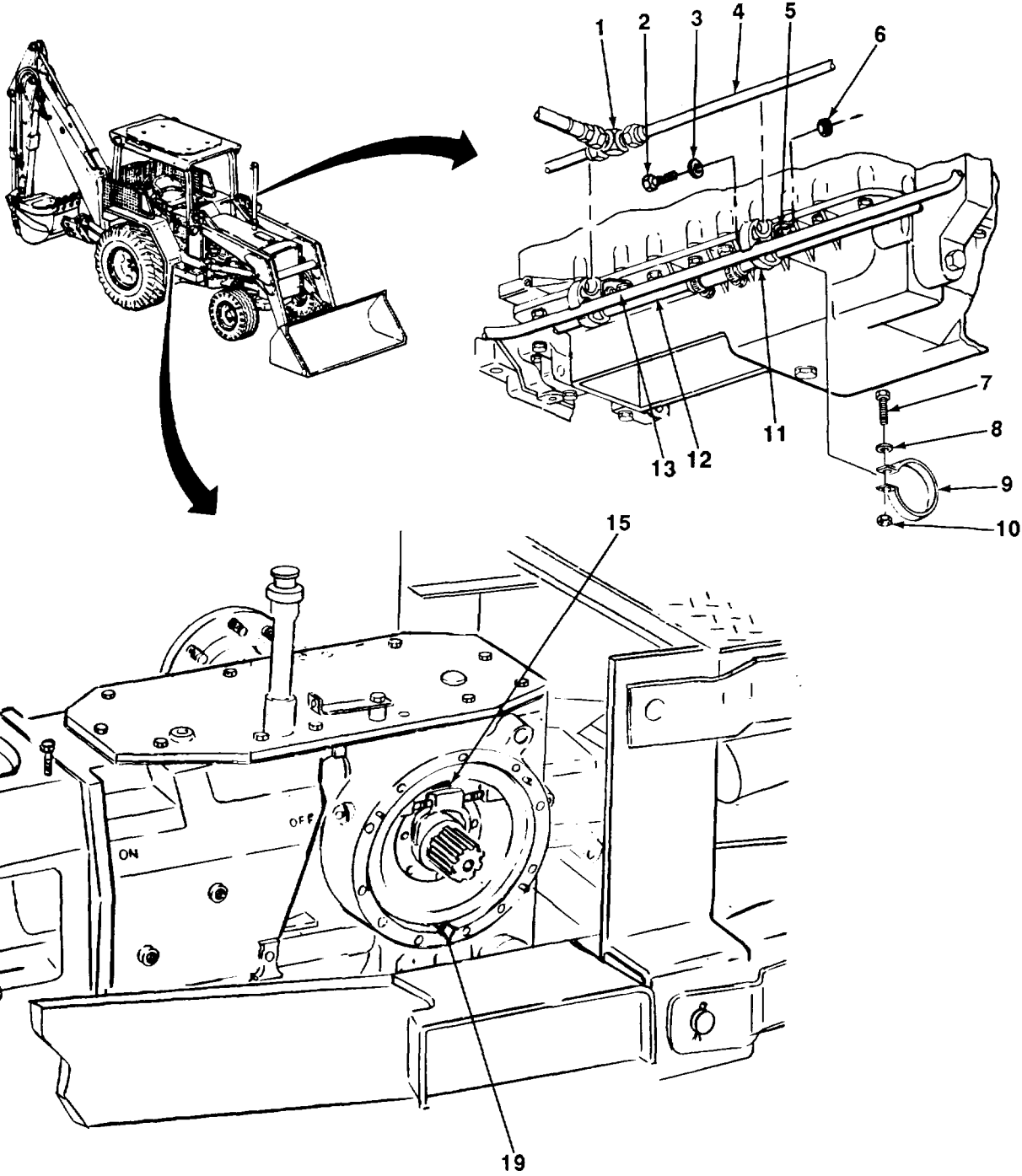

10-3. SERVICE BRAKE DISK AND PRESSURE PLATE REPAIR (Con't).

25. Unplug oil line (4), oil line (15), tee (1), and bleed passage (19).
26. Install plate spacer (11), capscrew (2), new lockwasher (3), and nut (6) on clamp angle bracket (5).
27. Position oil lines (4, 12, and 13) in spacer plate (11) and install clamp (9), screw (7), washer (8), and nut (10).
28. Connect oil line (4) to tee (1).

FOLLOW-ON TASKS:

- Install right or left rear axle housing (see paragraph 9-3).

10-4. HYDRAULIC BRAKE CYLINDER MAINTENANCE.

This Task Covers:

- | | |
|----------------------------|-----------------|
| a. Removal | d. Repair |
| b. Disassembly | e. Assembly |
| c. Cleaning and Inspection | f. Installation |
-

Initial Setup:

Equipment Conditions:

- Service brake pedals removed (see TM 5-2420-222-20).

Tools/Test Equipment:

- General mechanic's tool kit
- Field automotive shop set

Materials/Parts:

- Hydraulic fluid (Item 15, Appendix B)
- Dry cleaning solvent (Item 31, Appendix B)
- Rags (Item 28, Appendix B)
- One gasket
- Two lockwashers
- Two oil seals
- Twelve preformed packings

General Safety Instructions:

- Dry cleaning solvent is flammable and must not be used near open flame. Use only in a well-ventilated area.
-

a. REMOVAL**NOTE**

Use a drain pan to catch fluid when disconnecting lines from fittings. Clean up all spills.

1. Disconnect brake line (7) from elbow (6).
2. Disconnect brake line (9) from elbow (8).
3. Remove two capscrews (5) and lockwashers (4) from hydraulic cylinder (3) and reverser top cover (1). Discard lockwashers.
4. Remove hydraulic cylinder (3) and gasket (2) from reverser top cover (1). Discard gasket.

10-4. HYDRAULIC BRAKE CYLINDER MAINTENANCE (Con't).

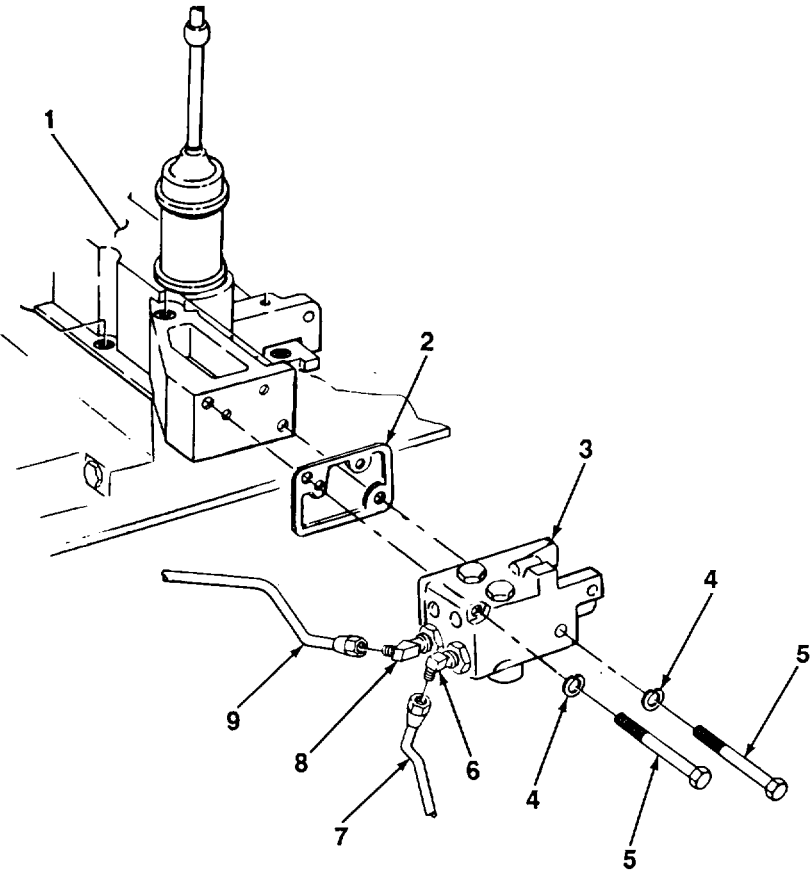

10-4. HYDRAULIC BRAKE CYLINDER MAINTENANCE (Con't).**b. DISASSEMBLY**

1. Remove bushing (11) and preformed packing (10) from hydraulic cylinder (3). Turn hydraulic cylinder over and drain hydraulic fluid into drain pan.
2. Remove preformed packing (10) from bushing (11). Discard preformed packing.
3. Remove elbow (6) and preformed packing (31) from check valve seat (30). Discard preformed packing.
4. Remove elbow (8) and preformed packing (32) from check valve seat (33). Discard preformed packing.
5. Remove check valve seat (30) and preformed packing (29) from hydraulic cylinder (3). Discard preformed packing.
6. Turn hydraulic cylinder (3) on end and remove spring (28), ball bearing (27), and retainer (26).
7. Remove check valve seat (33) and preformed packing (34) from hydraulic cylinder (3). Discard preformed packing.
8. Turn hydraulic cylinder (3) on end and remove spring (35), ball bearing (36), and retainer (37).
9. Push two pistons (24) and springs (25) out from pedal side of hydraulic cylinder (3).
10. Remove two oil seals (19) and preformed packings (18) from hydraulic cylinder (3). Discard oil seals and performed packing.
11. Remove bushing (12) and preformed packing (13) from hydraulic cylinder (3). Discard preformed packing.
12. Remove two check valves and springs (14), preformed packings (15), check valve disks (1 6), and springs (17) from hydraulic cylinder (3). Discard preformed packings.
13. Remove two drain plugs (23), preformed packings (22), springs (21), and ball bearings (20) from hydraulic cylinder (3). Discard preformed packings.
14. Remove pipe plug (38) from hydraulic cylinder (3).

c. CLEANING AND INSPECTION**WARNING**

Dry cleaning solvent, P-D-680, is toxic and flammable. Always wear protective goggles and gloves, and use only in a well-ventilated area. Avoid contact with skin, eyes, and clothes, and DO NOT breathe vapors. DO NOT use near open flame or excessive heat. The solvent's flash point is 1000F-1380F (380C-590C). If you become dizzy while using cleaning solvent, immediately get fresh air and medical help. If solvent contacts eyes, immediately wash your eyes and get medical aid.

1. Clean all metal parts with rags and dry cleaning solvent. Dry thoroughly with clean, dry rags.
2. Inspect all metal parts for cracks, breaks, and abnormal bends.
3. Inspect hydraulic cylinder for scoring, wear, cracks in hydraulic cylinder bores, and damage to ball seats.
4. Inspect all threaded parts for damaged threads.

10-4. HYDRAULIC BRAKE CYLINDER MAINTENANCE (Con't).

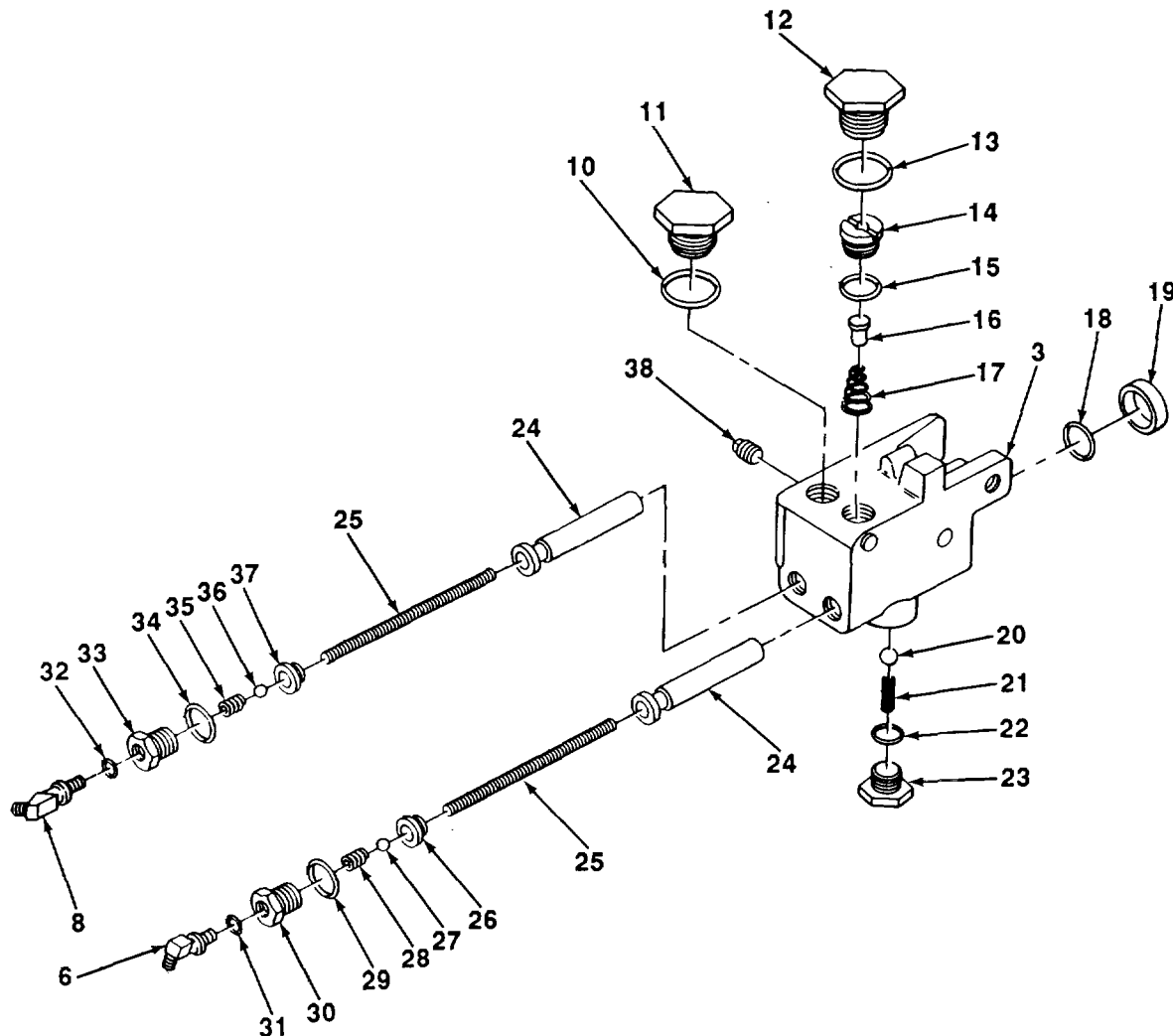

5. Using combination square, measure free length of piston springs. Free length must be 7.5 in. (190.5 mm).
6. Using spring tester, torque wrench, and combination square, compress piston springs to 5.75 in. (146.05 mm). It should require 20 lb.-ft. (27 N•m) to compress springs.
7. Using vernier calipers, measure free length of springs (21). Free length must be 0.797 in. (20.244 mm).
8. Using portable spring resiliency tester, torque wrench, and combination square, compress springs (21) to 0.281 in. (7.144 mm). It should require 1.8 lb.-in. (0.2 N•m) to compress springs.

d. REPAIR

Restore damaged threads using screw threading or pipe threading set.

TA701470

10-4. HYDRAULIC BRAKE CYLINDER MAINTENANCE (Con't).

e. ASSEMBLY

1. Install pipe plug (38) in hydraulic cylinder (3).
2. Turn hydraulic cylinder (3) over and install two ball bearings (20) and springs (21).
3. Coat two new preformed packings (22) with hydraulic fluid. Install two drain plugs (23) and preformed packings in hydraulic cylinder.
4. Turn hydraulic cylinder (3) over. Using magnetic retrieving tool, install two springs (17) and check valve disks (16).
5. Coat two new preformed packings (15) with hydraulic fluid.
6. Install two check valves and springs (14) and preformed packings (15) in hydraulic cylinder (3).
7. Coat new preformed packing (13) with hydraulic fluid. Install bushing (12) and preformed packing in hydraulic cylinder (3).
8. Coat two new preformed packings (18) with hydraulic fluid. Using remover and installer and ball-peen hammer, Install two new oil seals (19) with lips facing out and preformed packings in hydraulic cylinder (3).
9. Install two pistons (24) and springs (25) in check valve side of hydraulic cylinder (3).
10. Turn hydraulic cylinder (3) on end and install spring (35), ball bearing (36), and retainer (37).
11. Coat new preformed packing (34) with hydraulic fluid. Install check valve seat (33) and preformed packing in hydraulic cylinder (3).
12. Install spring (28), ball bearing (27), and retainer (26) in hydraulic cylinder (3).
13. Coat new preformed packing (29) with hydraulic fluid. Install check valve seat (30) and preformed packing in hydraulic cylinder (3).
14. Coat new preformed packing (32) with hydraulic fluid. Install elbow (8) and preformed packing in check valve seat (33).
15. Coat new preformed packing (31) with hydraulic fluid. Install elbow (6) and preformed packing in check valve seat (30).
16. Coat new preformed packing (10) with hydraulic fluid. Install preformed packing on bushing (11).
17. Install bushing (11) and preformed packing (10) in hydraulic cylinder (3).

10-4. HYDRAULIC BRAKE CYLINDER MAINTENANCE (Con't).

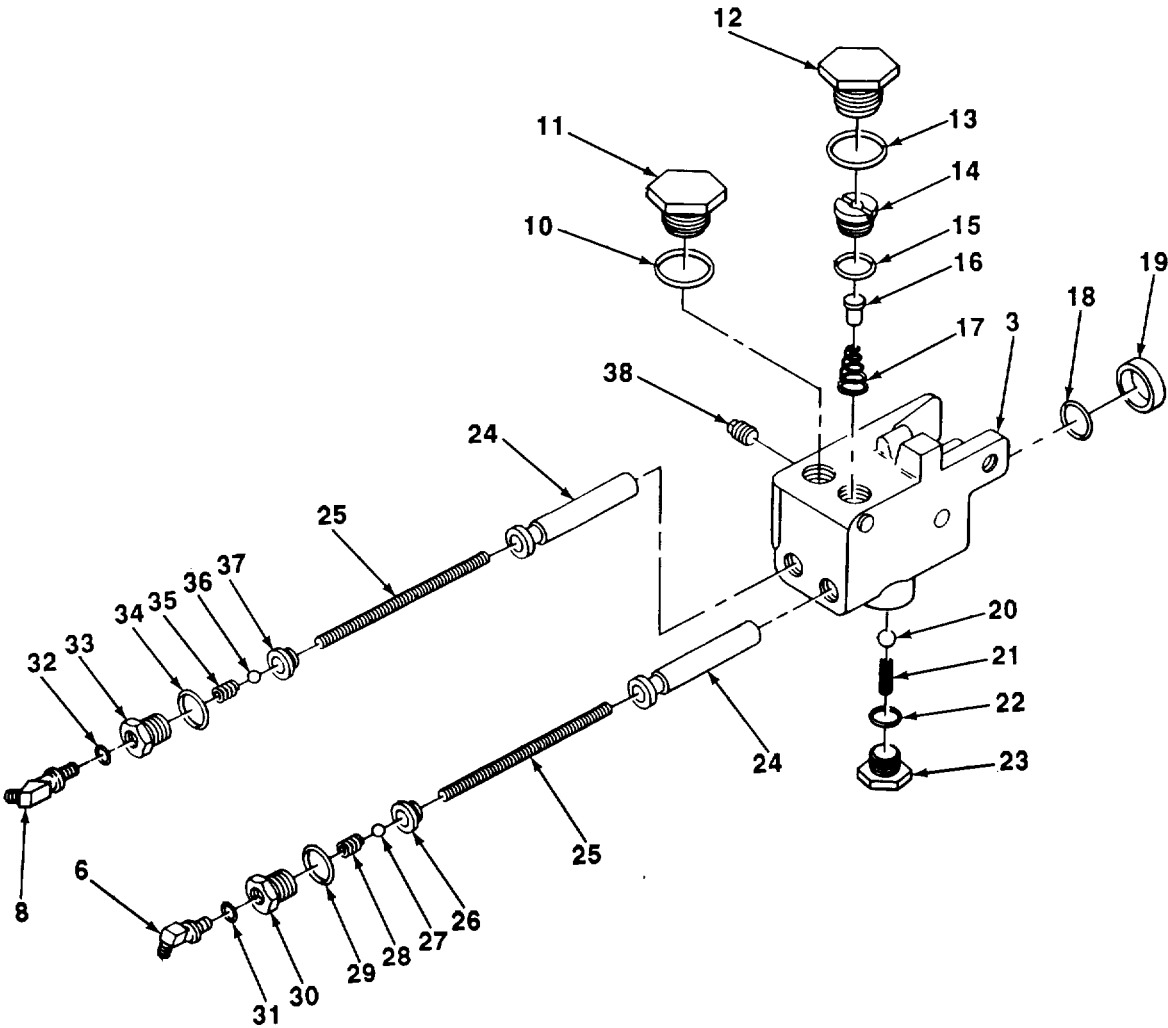

10-4. HYDRAULIC BRAKE CYLINDER MAINTENANCE (Con't).**f. INSTALLATION**

1. Position hydraulic cylinder (3) and new gasket (2) in place on reverser top cover (1).
2. Install two capscrews (5) and new lockwashers (4) in hydraulic cylinder (3) and reverser top cover (1).
3. Connect brake line (7) to elbow (6).
4. Connect brake line (9) to elbow (8).

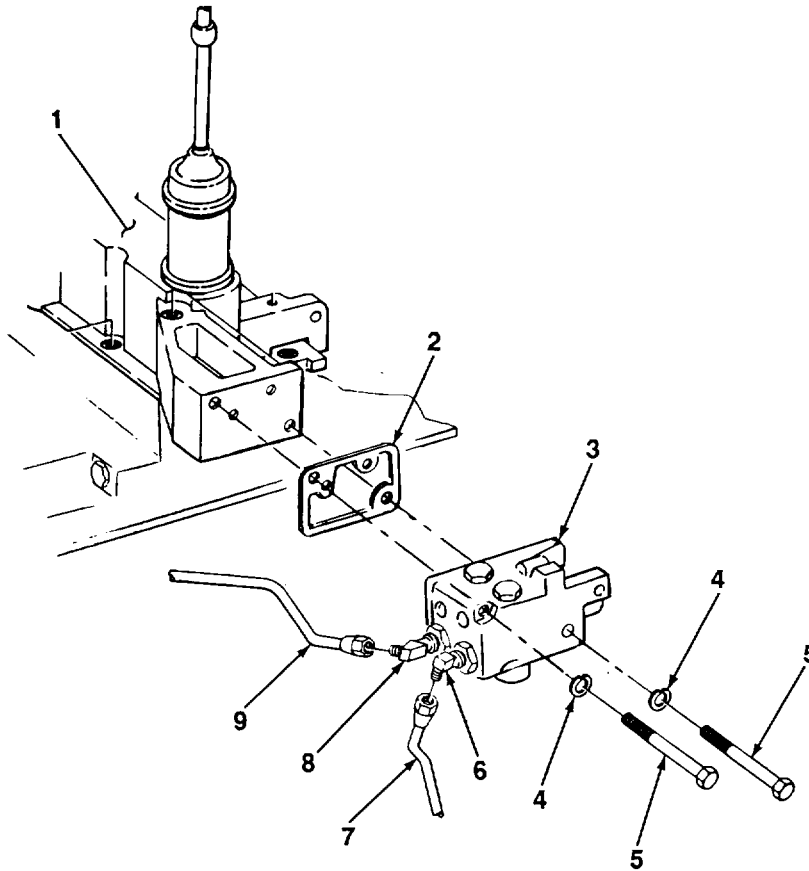
**FOLLOW-ON TASKS:**

- Install service brake pedals (see TM 5-2420-222-20).
- Bleed hydraulic brake system (see TM 5-2420-222-20).

TA701472

**CHAPTER 11
STEERING SYSTEM MAINTENANCE**

Paragraph Number	Paragraph Title	Page Number
11-1	Steering Column and Valve Support Maintenance	11-1
11-2	Steering Cylinder Assemblies Maintenance	11-7
11-3	Steering Valve Assembly Maintenance	11-18

11-1. STEERING COLUMN AND VALVE SUPPORT MAINTENANCE.

This Task Covers:

- | | |
|--|---|
| <ul style="list-style-type: none"> a. Removal b. Disassembly c. Cleaning and Inspection d. | <ul style="list-style-type: none"> d. Repair e. Assembly f. Installation |
|--|---|

Initial Setup:

Equipment Conditions:

- Steering wheel removed (see TM 5-2420-222-20).
- Speed gear (reverser) control lever removed (see TM 5-2420-222-20).

Materials/Parts:

- Rags (Item 28, Appendix B)
- Dry cleaning solvent (Item 31, Appendix B)
- Marker tags (Item 32, Appendix B)

Tools/Test Equipment:

- General mechanic's tool kit
- Field automotive shop set

General Safety Instructions:

- Dry cleaning solvent is flammable and must not be used near open flame. Use only in a well-ventilated area.

11-1. STEERING COLUMN AND VALVE SUPPORT MAINTENANCE (Con't).

a. REMOVAL**NOTE**

- Use a drain pan to catch fluid when disconnecting lines and hoses. Clean up all spills.
- Tag lines and hoses to ensure proper installation.

1. Disconnect line (2) from elbow (1).
2. Disconnect hose (8) from elbow (7).
3. Disconnect left-hand steering line (4) from elbow (3).
4. Disconnect right-hand steering line (5) from elbow (6).

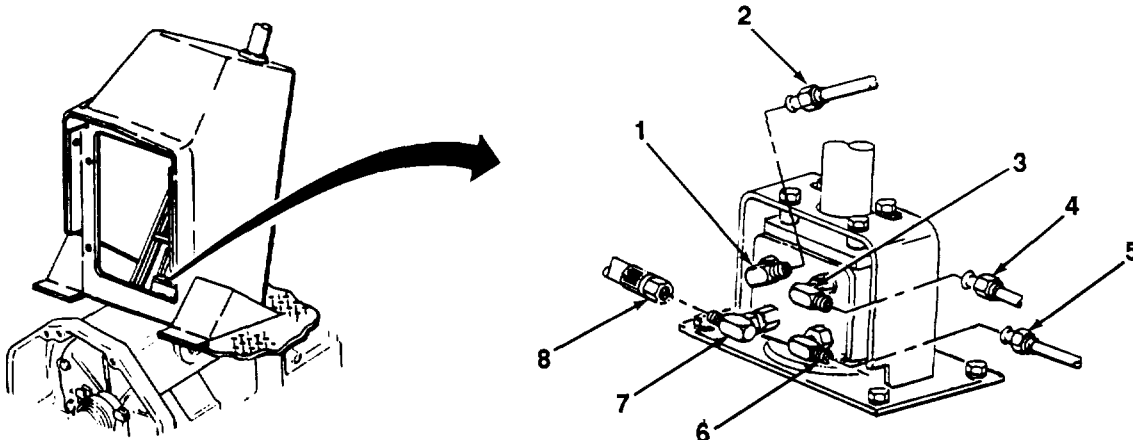
**NOTE**

Some loader backhoes do not have rear bracket and clamp. If parts are not present, skip steps 5 and 6.

5. Remove two capscrews (23), washers (24), retaining strap (22), lockwashers (11), and nuts (10) from steering column housing (21) and hanger (12). Discard lockwashers.
6. Remove two nuts (16), lockwashers (17), washers (18), and U-bolt (20) from steering column housing (21) and angle bracket (19). Discard lockwashers.
7. Remove four capscrews (25) and lockwashers (26) from steering valve support (27) and reverser housing (28). Discard lockwashers.
8. Remove steering column housing (21) with assembled parts from reverser housing (28) and angle bracket (19).
9. Remove two capscrews (15), angle bracket (19), lockwashers (13), and nuts (14) from cowl support (9). Discard lockwashers.

TA701473

11-1. STEERING COLUMN AND VALVE SUPPORT MAINTENANCE (Con't)

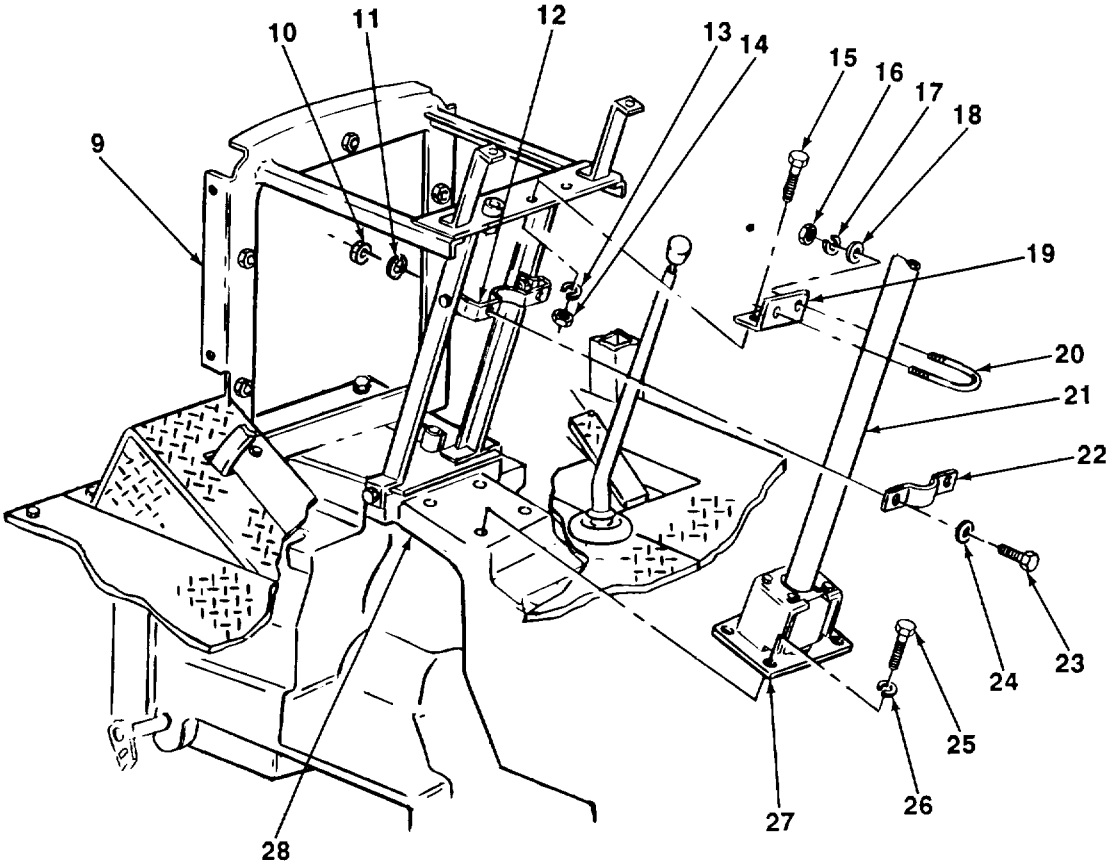

11-1. STEERING COLUMN AND VALVE SUPPORT MAINTENANCE (Con't)**b. DISASSEMBLY**

1. Remove four capscrews (29), lockwashers (30), and washers (31) from steering column housing (21), steering valve support (27), four sleeve spacers (32), and steering valve assembly (33). Discard lockwashers.
2. Remove steering valve assembly (33) and four sleeve spacers (32) from steering valve support (27).

c. CLEANING AND INSPECTION**WARNING**

Dry cleaning solvent, P-D-680, is toxic and flammable. Always wear protective goggles and gloves, and use only in a well-ventilated area. Avoid contact with skin, eyes, and clothes, and DO NOT breathe vapors. DO NOT use near open flame or excessive heat. The solvent's flash point is 100 °F-138°F (38 °C-59 °C). If you become dizzy while using cleaning solvent, immediately get fresh air and medical help. If solvent contacts eyes, immediately wash your eyes and get medical aid.

1. Clean all metal parts with dry cleaning solvent and clean rags. Dry thoroughly with clean, dry rags.
2. Inspect all metal parts for cracks, breaks, and abnormal bends.
3. Inspect all threaded parts for damaged threads.

d. REPAIR

Restore damaged threads using screw threading set.

e. ASSEMBLY

1. Position steering valve assembly (33) and four sleeve spacers (32) in place on steering valve support (27).
2. Position steering column housing (21) in place on steering valve support (27).
3. Install four capscrews (29), new lockwashers (30), and washers (31) in steering column housing (21), four sleeve spacers (32), steering valve support (27), and steering valve assembly (33).

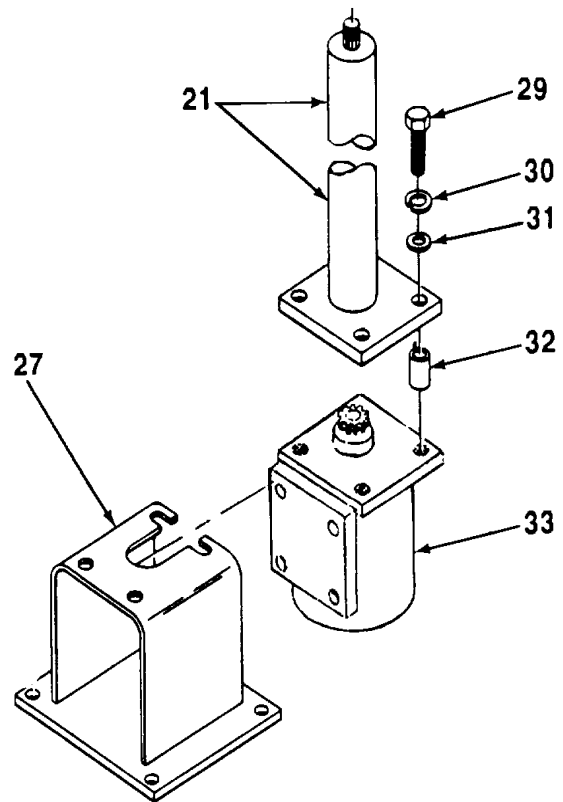

TA701475

11-1. STEERING COLUMN AND VALVE SUPPORT MAINTENANCE (Con't).

f. INSTALLATION

1. Position angle bracket (19) in place on cowl support (9) and secure with two capscrews (15), new lockwashers
2. Position steering column housing (21) with assembled parts in place on reverser housing (28).
3. Install four capscrews (25) and new lockwashers (26) in steering valve support (27) and reverser housing (28).
4. Install U-bolt (20), two washers (18), new lockwashers (17), and nuts (16) on steering column housing (21) and angle bracket (19).

NOTE

Some loader backhoes do not have rear bracket and clamp. If parts are not present, skip step 5.

5. Install retaining strap (22), two capscrews (23), washers (24), new lockwashers (11), and nuts (10) in hanger (12) on cowl support (9).

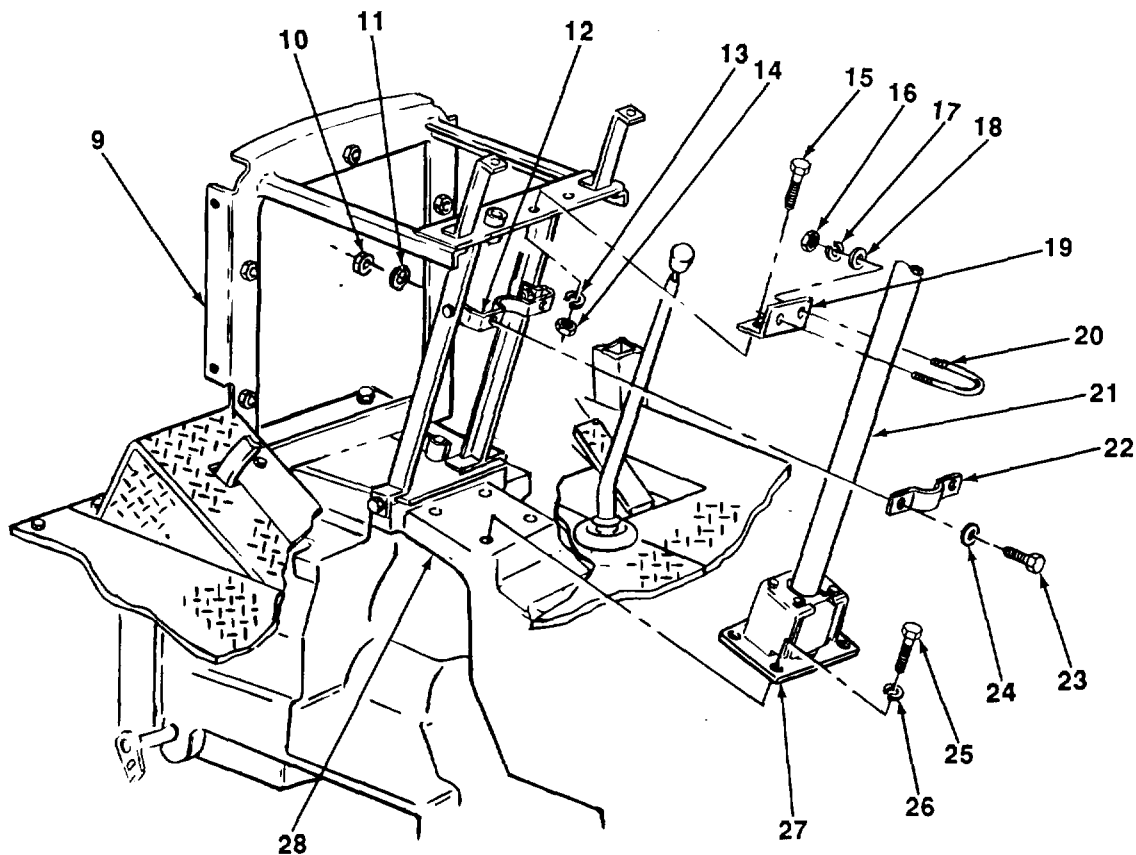

11-1. STEERING COLUMN AND VALVE SUPPORT MAINTENANCE (Con't).

6. Connect right-hand steering line (5) to elbow (6).
7. Connect left-hand steering line (4) to elbow (3).
8. Connect hose (8) to elbow (7).
9. Connect line (2) to elbow (1).

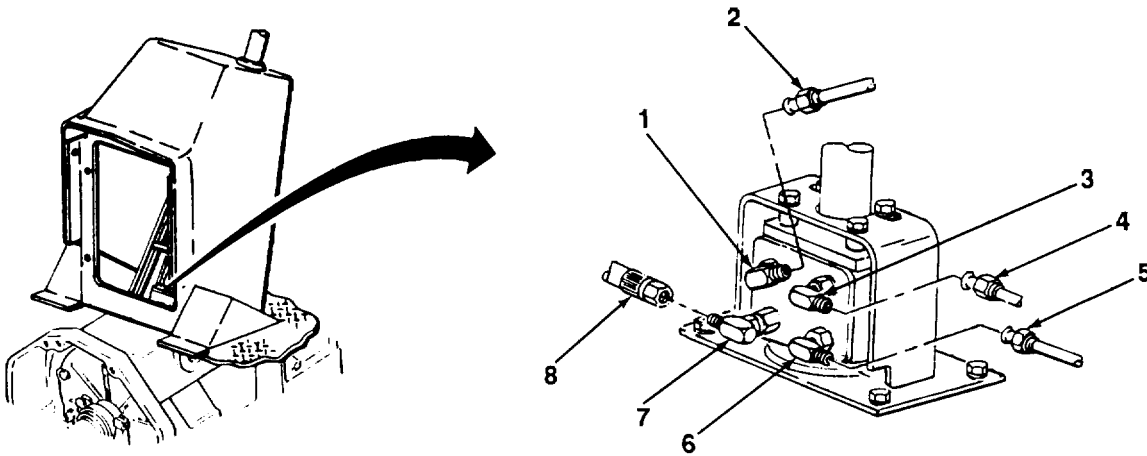
**FOLLOW-ON TASKS:**

- Install speed gear (reverser) control lever (see TM 5-2420-222-20).
- Install steering wheel (see TM 5-2420-222-20).
- Check transmission fluid level and add fluid as required (see LO 5-2420-222-12).
- Start engine assembly (see TM 5-2420-222-10). Check all steering valve connections for leaks. Tighten any leaking connections.
- Shut down engine assembly (see TM 5-2420-222-10).

TA701477

11-2. STEERING CYLINDER ASSEMBLIES MAINTENANCE.

This Task Covers:

- | | |
|----------------------------|-----------------|
| a. Removal | d. Repair |
| b. Disassembly | e. Assembly |
| c. Cleaning and Inspection | f. Installation |
-

Initial Setup:

Equipment Conditions:

- Hydraulic pump assembly removed (see paragraph 14-3).

Tools/Test Equipment:

- General mechanic's tool kit
- Field automotive shop set

Personnel Required: Two

Materials/Parts:

- Abrasive cloth (Item 5, Appendix B)
- Hydraulic fluid (Item 15, Appendix B)
- Rags (Item 28, Appendix B)
- Dry cleaning solvent (Item 31, Appendix B)
- Marker tags (Item 32, Appendix B)
- One packing and seal kit
- One self-locking nut
- Two cotter pins

General Safety Instructions:

- Dry cleaning solvent is flammable and must not be used near open flame. Use only in a well-ventilated area.
-

NOTE

Loader backhoes with serial numbers 235786-235999 have two steering cylinders. Loader backhoes with serial numbers 319995-342573 have one steering cylinder. All steering cylinders are maintained the same way, except as noted. One steering cylinder is shown. Repeat procedure as required.

11-2. STEERING CYLINDER ASSEMBLIES MAINTENANCE (Con't).

a. REMOVAL

NOTE

- Steps 1 and 2 apply to elbow on piston rod end of both right and left steering cylinders on loader backhoes with serial numbers 235786-235999 and to both elbows on the steering cylinder on loader backhoes with serial numbers 319995-342573. Repeat steps as required.
- Use a drain pan to catch fluid when disconnecting hoses. Clean up all spills.
- Tag hoses to ensure proper Installation.

1. Disconnect hose (13) from elbow (14).
2. Remove elbow (14) and preformed packing (15) from actuating cylinder (16). Discard preformed packing.

NOTE

Steps 3 and 4 apply only to loader backhoes with serial numbers 235786-235999.

3. Disconnect hoses (4 and 7) from elbow (6).

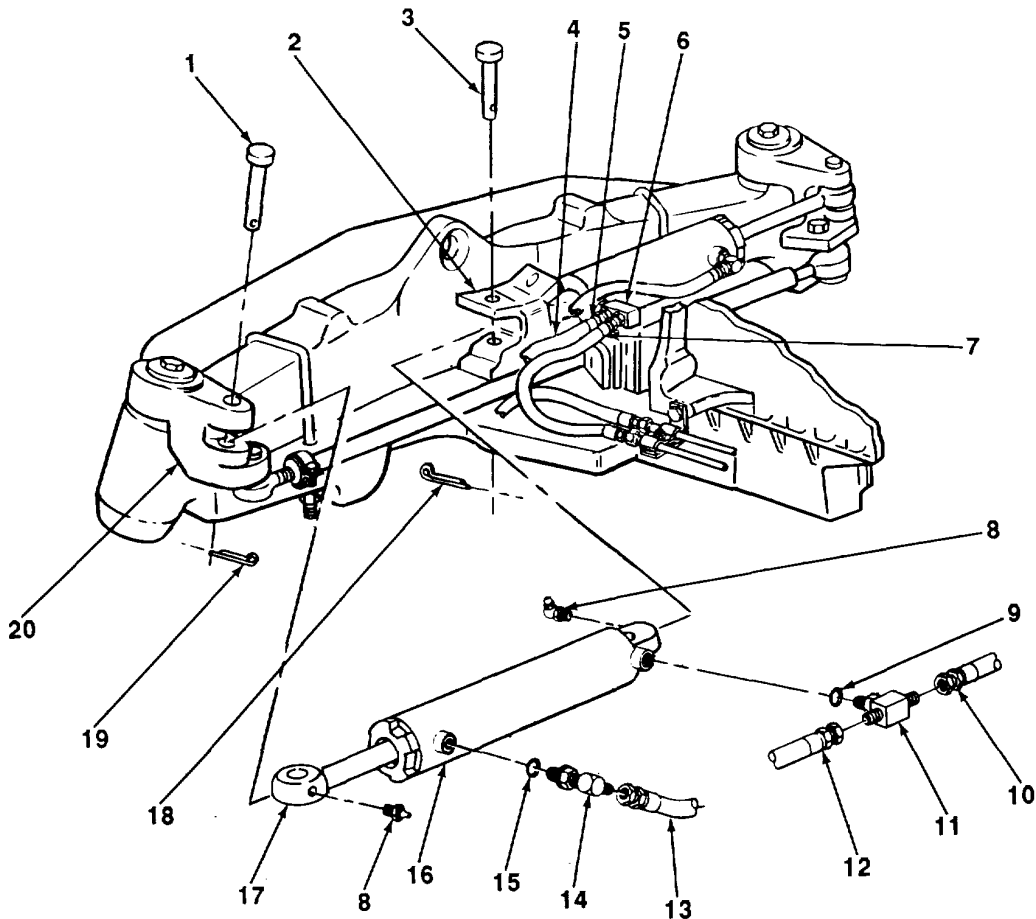

11-2. STEERING CYLINDER ASSEMBLIES MAINTENANCE (Con't).

4. Remove elbow (6) and preformed packing (5) from actuating cylinder (16). Discard preformed packing.

NOTE

Steps 5 and 6 apply only to left steering cylinder on loader backhoes with serial numbers 235786-235999.

5. Remove two hoses (10 and 12) from tee (11).
6. Remove tee (11) and preformed packing (9) from actuating cylinder (16). Discard preformed packing.
7. Remove cotter pin (19) from pin (1). Discard cotter pin.
8. Drive pin (1) out of steering arm (20) and piston rod (17).
9. Remove cotter pin (18) from pin (3). Discard cotter pin.
10. Drive pin (3) out of front axle (2) and actuating cylinder (16).
11. Remove actuating cylinder (16) with assembled parts from front axle (2) and steering arm (20).
12. With the aid of an assistant, work piston rod (17) in and out of actuating cylinder (16) and drain oil.

b. DISASSEMBLY

1. If damaged, remove two lubrication fittings (8) from actuating cylinder (16) and piston rod (17).

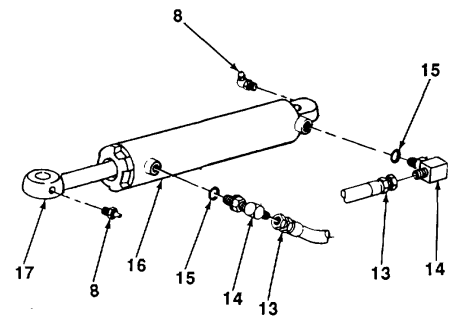

SERIAL NUMBERS 319995-342573

TA701479

11-2. STEERING CYLINDER ASSEMBLIES MAINTENANCE (Con't).

- 2. Remove setscrew (33) from actuating cylinder (16).

NOTE

**Step 3 applies only to loader backhoes with serial numbers 235786-235999.
SERIAL NUMBERS Z3/517-Z23599**

- 3. Using spanner wrench, loosen and slide retainer (29) back on piston rod (17).

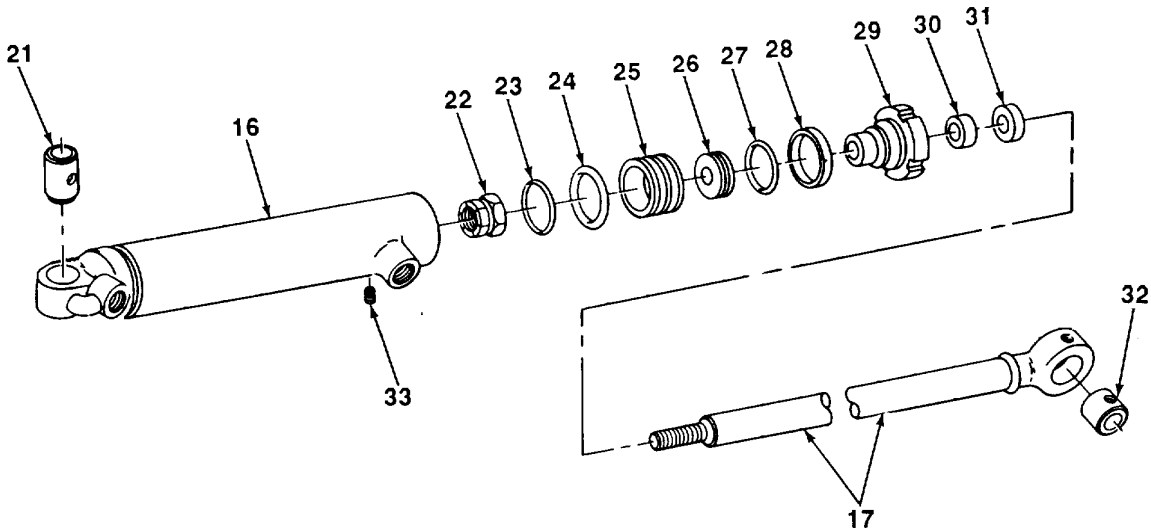

SERIAL NUMBERS 235786-235999

NOTE

Step 4 applies only to loader backhoes with serial numbers 319995-342573.

- 4. Using spanner wrench, loosen and slide valve stem guide (42) back on piston rod (17).

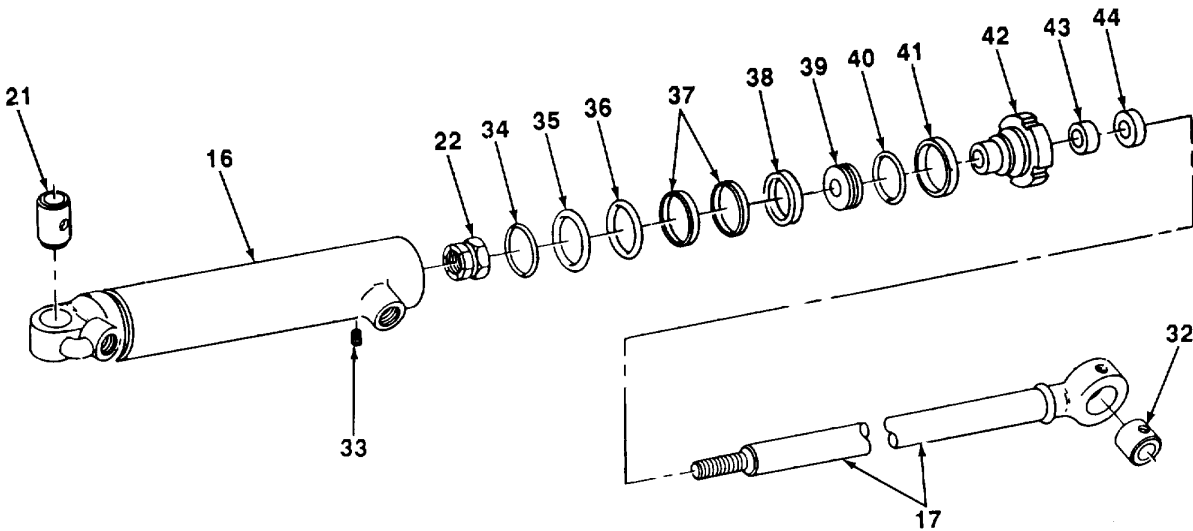

SERIAL NUMBERS 319995-342573

11-2. STEERING CYLINDER ASSEMBLIES MAINTENANCE (Con't).

5. Place actuating cylinder (16) in a vise with caps. With the aid of an assistant, pull piston rod (17) with assembled parts out of actuating cylinder. Remove actuating cylinder from vise.
6. Place piston rod (17) with assembled parts in a vise with caps.
7. Remove self-locking nut (22) and piston (25) or valve piston (39) with assembled parts from piston rod (17). Discard self-locking nut.
8. Remove piston rod (17) from vise.

NOTE

Steps 9 through 11 apply only to loader backhoes with serial numbers 235786-235999.

9. Remove retainer (29) with assembled parts from piston rod (17).
10. Remove preformed packing (23), piston seal (24), and wear ring (26) from piston (25). Discard preformed packing, piston seal, and wear ring.
11. Remove preformed packing (27), backup leather (28), wiper seal (31), and rod seal (30) from retainer (29). Discard preformed packing, backup leather, wiper seal, and rod seal.

NOTE

Steps 12 through 14 apply only to loader backhoes with serial numbers 319995-342573.

12. Remove valve stem guide (42) with assembled parts from piston rod (17).
13. Remove wiper ring (38), two spacer rings (37), preformed packing (34), piston seal (35), and preformed packing (36) from valve piston (39). Discard preformed packings, spacer rings, piston seal, and wiper ring.
14. Remove preformed packing (40), packing retainer (41), seal (44), and preformed packing (43) from valve stem guide (42). Discard preformed packings, packing retainer, and seal.

CAUTION

Perform step 15 only if sleeve bushings are damaged. Removal may damage parts.

15. Using remover and installer and arbor press, drive sleeve bushings (21 or 32) from actuating cylinder (16) or piston rod (17).

c. CLEANING AND INSPECTION**WARNING**

Dry cleaning solvent, P-D-680, is toxic and flammable. Always wear protective goggles and gloves, and use only in a well-ventilated area. Avoid contact with skin, eyes, and clothes, and DO NOT breathe vapors. DO NOT use near open flame or excessive heat. The solvent's flash point is 100°F-138°F (38°C-59°C). If you become dizzy while using cleaning solvent, immediately get fresh air and medical help. If solvent contacts eyes, immediately wash your eyes and get medical aid.

1. Clean all metal parts with dry cleaning solvent and clean rags. Dry thoroughly with clean, dry rags.
2. Inspect all metal parts for cracks, breaks, and abnormal bends.

11-2. STEERING CYLINDER ASSEMBLIES MAINTENANCE (Con't).

3. Inspect all threaded parts for damaged threads.
4. Inspect actuating cylinder and piston rod for scoring, pits, and corrosion.
5. Inspect sleeve bushings for excessive wear, burrs, and chips.

d. REPAIR

1. Restore damaged threads using screw threading set.
2. Remove any minor scoring, pits, and corrosion from actuating cylinder or piston rod with 600 grit abrasive cloth.

e. ASSEMBLY

NOTE

Perform step 1 only if sleeve bushing was removed.

1. Using remover and installer and arbor press, install sleeve bushings (21 or 32) in actuating cylinder (16) or piston rod (17).

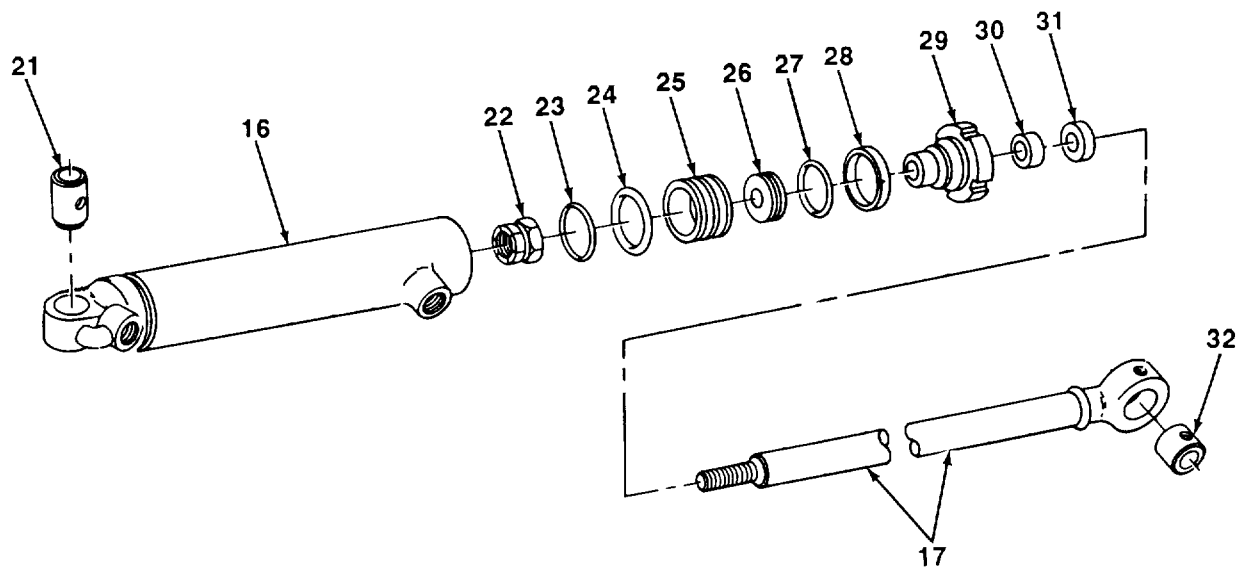

SERIAL NUMBERS 235786-235999

NOTE

Steps 2 through 7 apply only to loader backhoes with serial numbers 319995-342573.

2. Coat new seal (44), new preformed packing (43), new packing retainer (41), and new preformed packing (40) with hydraulic fluid.
3. Install preformed packing (43), seal (44), packing retainer (41), and preformed packing (40) on valve guide stem (42).
4. Install valve guide stem (42) with assembled parts in place on piston rod (17).

11-2. STEERING CYLINDER ASSEMBLIES MAINTENANCE (Con't).

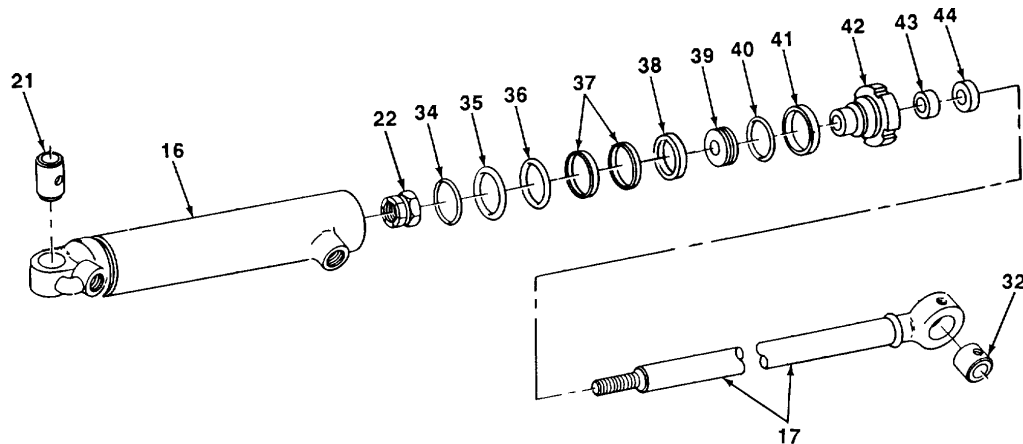
**SERIAL NUMBERS 319995-342573**

5. Coat new preformed packing (36), new piston seal (35), new preformed packing (34), two new spacer rings (37), and new wiper ring (38) with hydraulic fluid.
6. Install wiper ring (38), two spacer rings (37), preformed packing (34), piston seal (35), and preformed packing (36) in place on valve piston (39).
7. Install valve piston (39) with assembled parts in place on piston rod (17).

NOTE

Steps 8 through 13 apply only to loader backhoes with serial numbers 235786-235999.

8. Coat new wiper seal (31), new rod seal (30), new backup leather (28), and new preformed packing (27) with hydraulic fluid.
9. Install rod seal (30), wiper seal (31), backup leather (28), and preformed packing (27) in place on retainer (29).
10. Install retainer (29) with assembled parts in place on piston rod (17).
11. Coat new wear ring (26), new preformed packing (23), and new piston seal (24) with hydraulic fluid.
12. Install wear ring (26), preformed packing (23), and piston seal (24) in place on piston (25).
13. Install piston (25) with assembled parts in place on piston rod (17).
14. Place piston rod (17) in a vise with caps. Install new self-locking nut (22) on piston rod. Torque nut to 65-80 lb.-ft. (88-108 N•m). Remove piston rod from vise.
15. Place actuating cylinder (16) in a vise with caps.
16. Using piston ring compressor and the aid of an assistant, install piston rod (17) with assembled parts in actuating cylinder (16).

NOTE

Step 17 applies only to loader backhoes with serial numbers 319995-342573.

17. Slide valve stem guide (42) against actuating cylinder (16). Using spanner wrench, install valve stem guide in actuating cylinder.

11-2. STEERING CYLINDER ASSEMBLIES MAINTENANCE (Con't).

NOTE

Step 18 applies only to loader backhoes with serial numbers 235786-235999.

- 18. Slide retainer (29) against actuating cylinder (16). Using spanner wrench, install retainer in actuating cylinder.

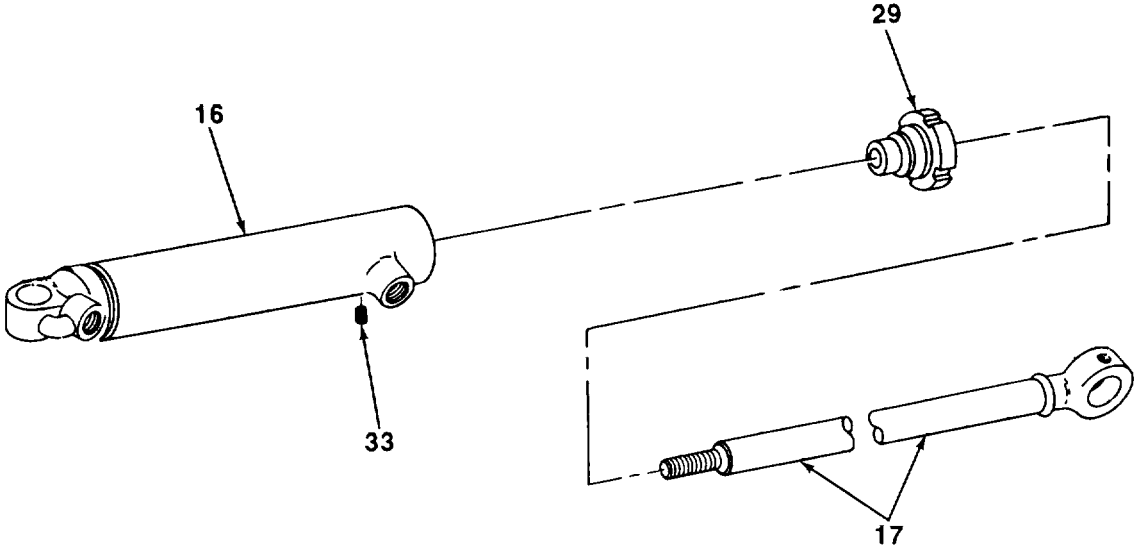

SERIAL NUMBERS 235786-235999

- 19. Install setscrew (33) in actuating cylinder (16). Torque setscrew to 40 lb.-in. (4.5 N•m).

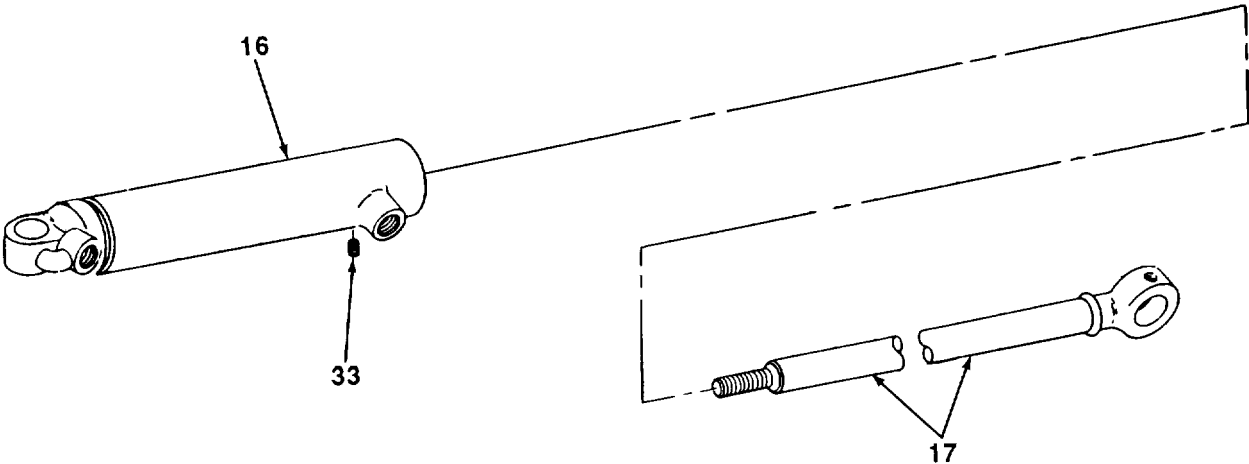

SERIAL NUMBERS 319995-342573

11-2. STEERING CYLINDER ASSEMBLIES MAINTENANCE (Con't).

20. If removed, install two lubrication fittings (8) in actuating cylinder (16) and piston rod (17).
21. Remove actuating cylinder (16) from vise.

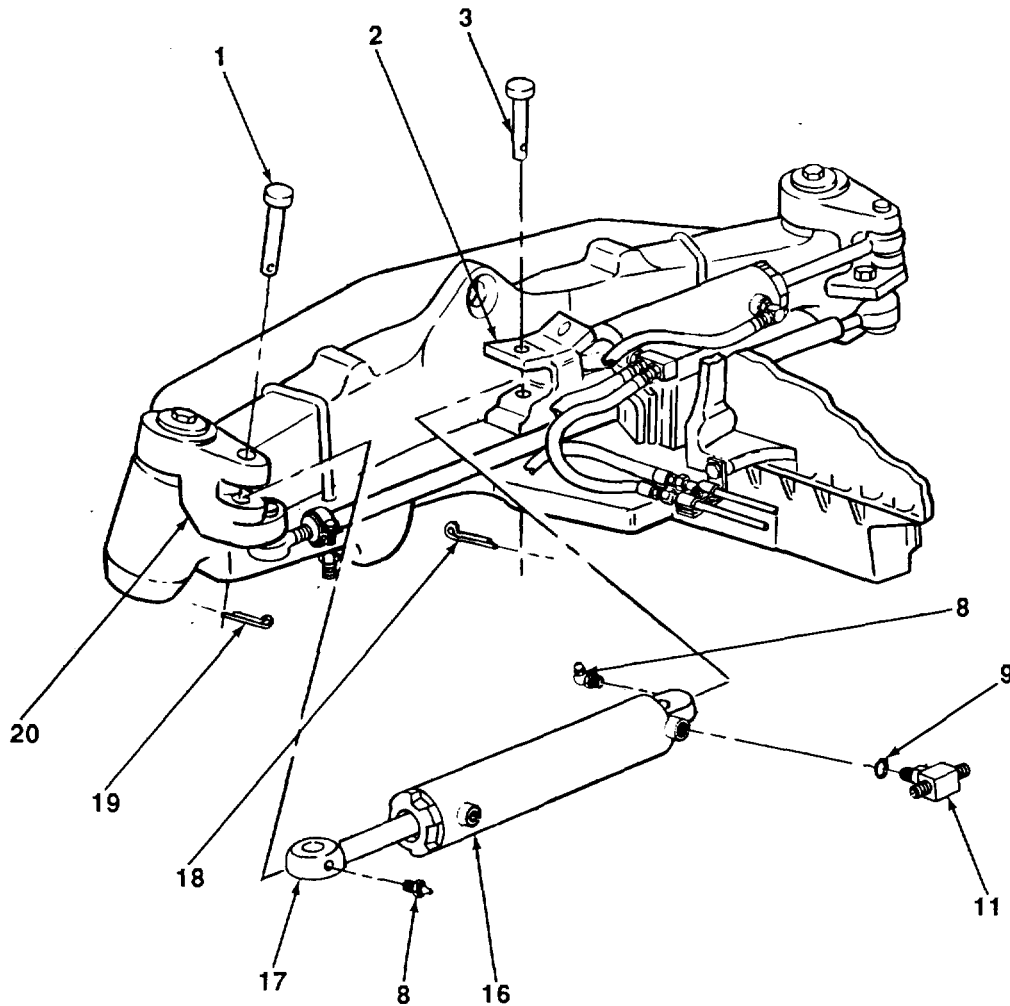
**f. INSTALLATION**

1. Install actuating cylinder (16) with assembled parts in place on front axle (2) and steering arm (20).
2. Drive pin (3) in actuating cylinder (16) and front axle (2). Secure pin with new cotter pin (18).
3. Drive pin (1) in steering arm (20) and piston rod (17). Secure pin with new cotter pin (19).

NOTE

Steps 4 and 5 apply only to left steering cylinder on loader backhoes with serial numbers 235786-235999.

4. Install tee (11) and new preformed packing (9) in actuating cylinder (16).

11-2. STEERING CYLINDER ASSEMBLIES MAINTENANCE (Con't).

5. Connect two hoses (10 and 12) to tee (11).

NOTE

Steps 6 and 7 apply only to loader backhoes with serial numbers 235786-235999.

6. Install elbow (6) and new preformed packing (5) in actuating cylinder (16).

7. Connect two hoses (4 and 7) to elbow (4).

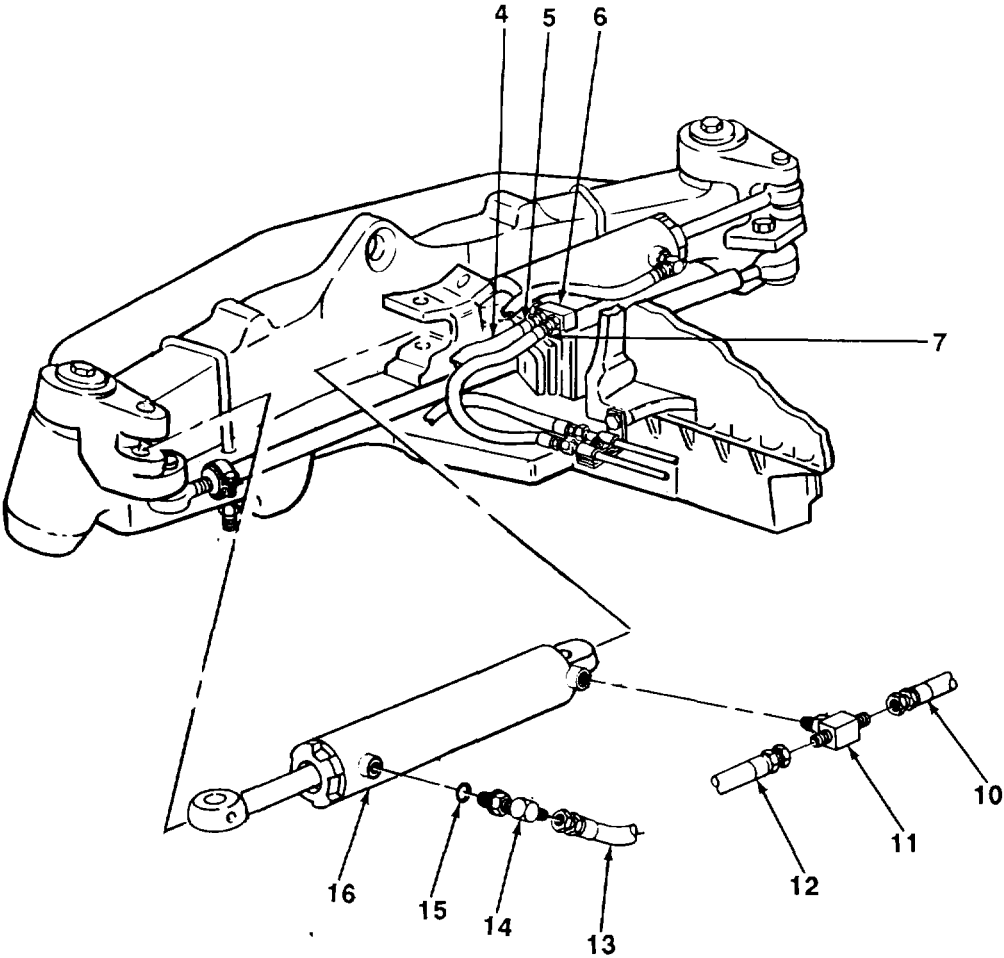

11-2. STEERING CYLINDER ASSEMBLIES MAINTENANCE (Con't).**NOTE**

Steps 8 and 9 apply to elbow on piston rod end of both left and right steering cylinders on loader backhoes with serial numbers 235786- 235999 and to both elbows on loader back- hoes with serial numbers 319995-342573. Repeat steps as required.

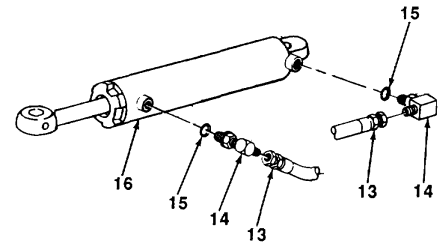

8. Install elbow (14) and new preformed packing (15) in actuating cylinder (16).
9. Connect hose (13) to elbow (14).

SERIAL NUMBERS 319995-342573

FOLLOW-ON TASKS:

- Install hydraulic pump assembly (see paragraph 14-3).
- Check transmission fluid level and fill as required (see LO 5-2420-222-12).
- Turn wheels from side to side and check all hoses and fittings for leaks. Tighten any leaking connections.
- Start engine assembly (see TM 5-2420-222-10).
- Shut down engine assembly (see TM 5-2420-222-10).

TA701486

11-3. STEERING VALVE ASSEMBLY MAINTENANCE.

This Task Covers:

- | | |
|----------------------------|-------------|
| a. Disassembly | c. Repair |
| b. Cleaning and Inspection | d. Assembly |
-

Initial Setup:

Equipment Conditions:

- Steering column and valve support removed (see paragraph 11-1).

Tools/Test Equipment:

- General mechanic's tool kit
- Field automotive shop set

Materials/Parts:

- Abrasive cloth (Item 5, Appendix B)
- Hydraulic fluid (Item 15, Appendix B)
- Rags (Item 28, Appendix B)
- Dry cleaning solvent (Item 31, Appendix B)
- Three preformed packings (serial numbers 235786- 235999)
- Eight preformed packings (serial numbers 319995-342573)

General Safety Instructions:

- Dry cleaning solvent is flammable and must not be used near open flame. Use only in a well-ventilated area.
 - Compressed air used for cleaning purposes should never exceed 30 psi (207 kPa).
-

a. DISASSEMBLY

- Remove seven bolts (15) and cover (16) from valve housing (8).

NOTE

Step 2 applies only to loader backhoes with serial numbers 235786-235999.

- Remove outer and inner gear (17 and 18), plate spacer (19), sleeve spacer (20), and drive shaft (21) from valve housing (8).

NOTE

Step 3 applies only to loader backhoes with serial numbers 319995-342573.

- Remove outer and inner gear (17 and 18), plate spacer (19), sleeve spacer (20), drive shaft (21), and three preformed packings (23) from valve housing (8). Discard preformed packings.

NOTE

Perform steps 4 through 6 only if valve housing, spool, or sleeve is damaged. Valve housing, spool, and sleeve are a matched set and must be replaced together.

- Remove centering straight pin (12) from spool (13) and sleeve (14).
- Push spool (13) toward splined end. While rotating spool slightly in valve housing (8), remove spool and sleeve (14).
- Remove six centering springs (22) from spool (13) and sleeve (14).

NOTE

Step 7 applies only to loader backhoes with serial numbers 235786-235999.

- Remove threaded insert (11), lockpin (10), and bearing ball (9) from valve housing (8).

11-3. STEERING VALVE ASSEMBLY MAINTENANCE (Con't).

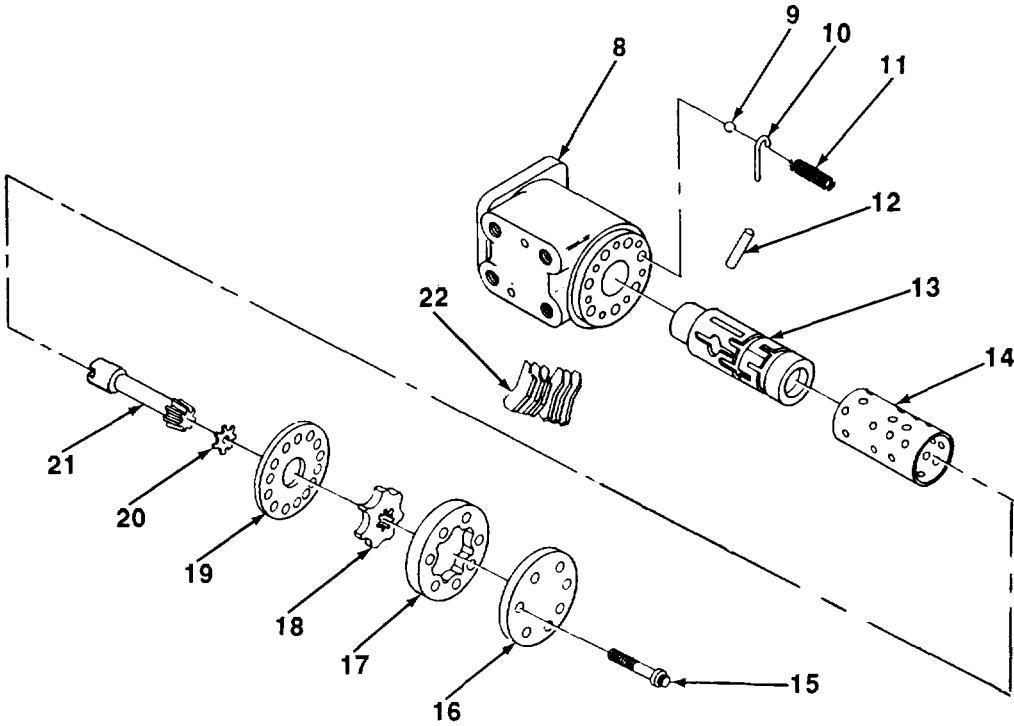

SERIAL NUMBERS 235786-235999

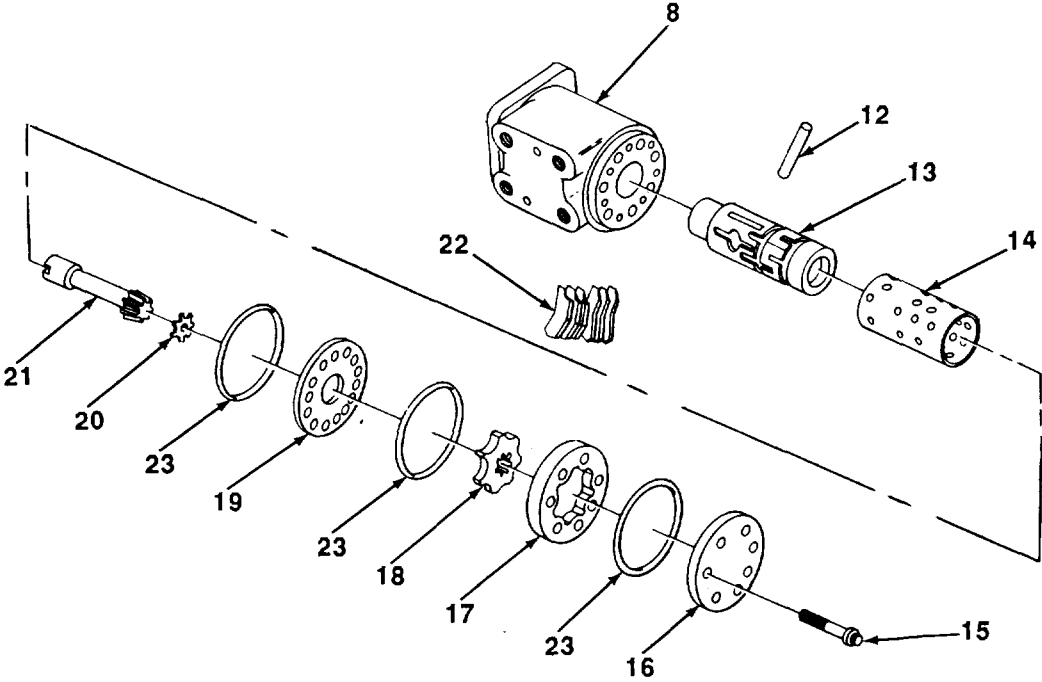

SERIAL NUMBERS 319995-342573

11-3. STEERING VALVE ASSEMBLY MAINTENANCE.

NOTE

Steps 8 and 9 applies only to loader backhoes with serial numbers 319995-342573.

8. Remove setscrew (29), valve seat (27), bearing ball (25), and retainer (24) from valve housing (8).
9. Remove two preformed packings (26 and 28) from valve seat (27). Discard preformed packings.
10. Using retaining ring pliers, remove retaining ring (2) from valve housing (8).
11. Remove packing retainer (3) with assembled parts, two bearing seats (6), and retainer and roller (7) from valve.
12. Remove three preformed packings (1, 4, and 5) from packing retainer (3). Discard preformed packings.

b. CLEANING AND INSPECTION**WARNING**

- **Dry cleaning solvent, P-D-680, is toxic and flammable. Always wear protective goggles and gloves, and use only in a well-ventilated area. Avoid contact with skin, eyes, and clothes, and DO NOT breathe vapors. DO NOT use near open flame or excessive heat. The solvent's flash point is 100°F-138°F (38°C-59°C). If you become dizzy while using cleaning solvent, immediately get fresh air and medical help. If solvent contacts eyes, immediately wash your eyes and get medical aid.**
- **Compressed air used for cleaning or drying purposes, or for clearing restrictions, should never exceed 30 psi (207 kPa). Wear protective clothing (goggles/shield, gloves, etc.) and use caution to avoid injury to personnel.**

1. Clean all metal parts with dry cleaning solvent and rags. Dry thoroughly with compressed air.
2. Inspect all metal parts for cracks, breaks, and abnormal bends.
3. Inspect drive shaft for cracks, corrosion, chipped or missing gear teeth.
4. Inspect valve housing for damaged threads.

c. REPAIR

1. Remove any corrosion from drive shaft (21) using 600 grit abrasive cloth.
2. Restore damaged valve housing (8) threads using screw threading set.

d. ASSEMBLY**NOTE**

Steps 1 and 2 apply only to loader backhoes with serial numbers 319995-342573.

1. Coat two new preformed packings (26 and 28) with hydraulic fluid. Install preformed packings on valve seat (27).
2. Install retainer (24), bearing ball (25), valve seat (27) with assembled parts, and setscrew (29) in valve housing (8). Torque setscrew to 100 lb.-in. (11.3 N•m).

11-3. STEERING VALVE ASSEMBLY MAINTENANCE.

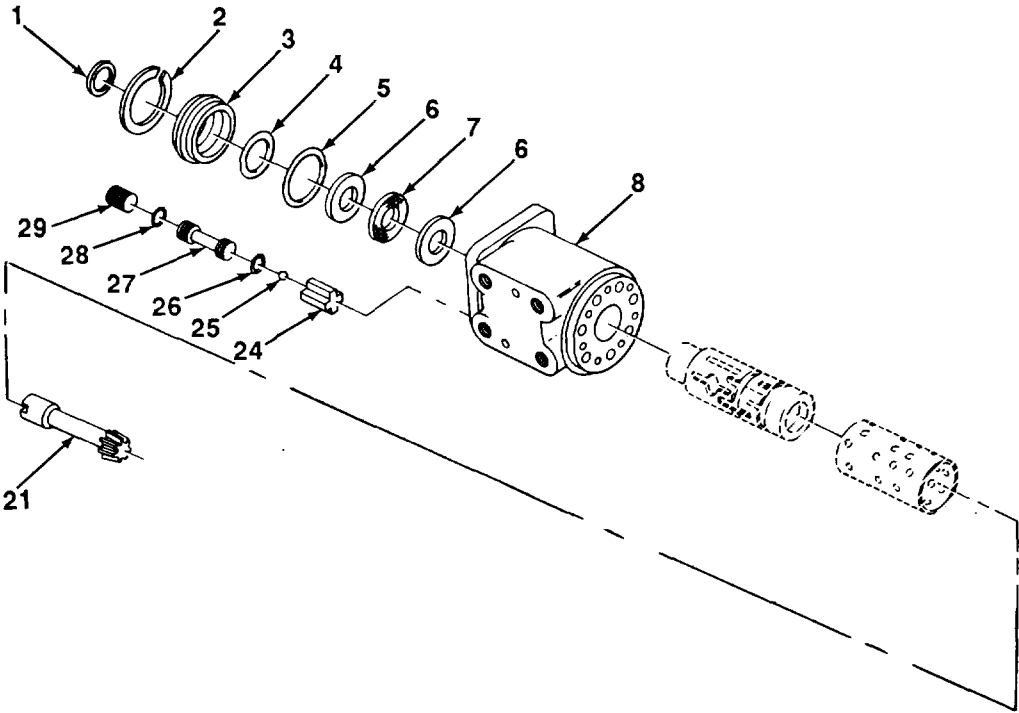

SERIAL NUMBERS 31995-342573

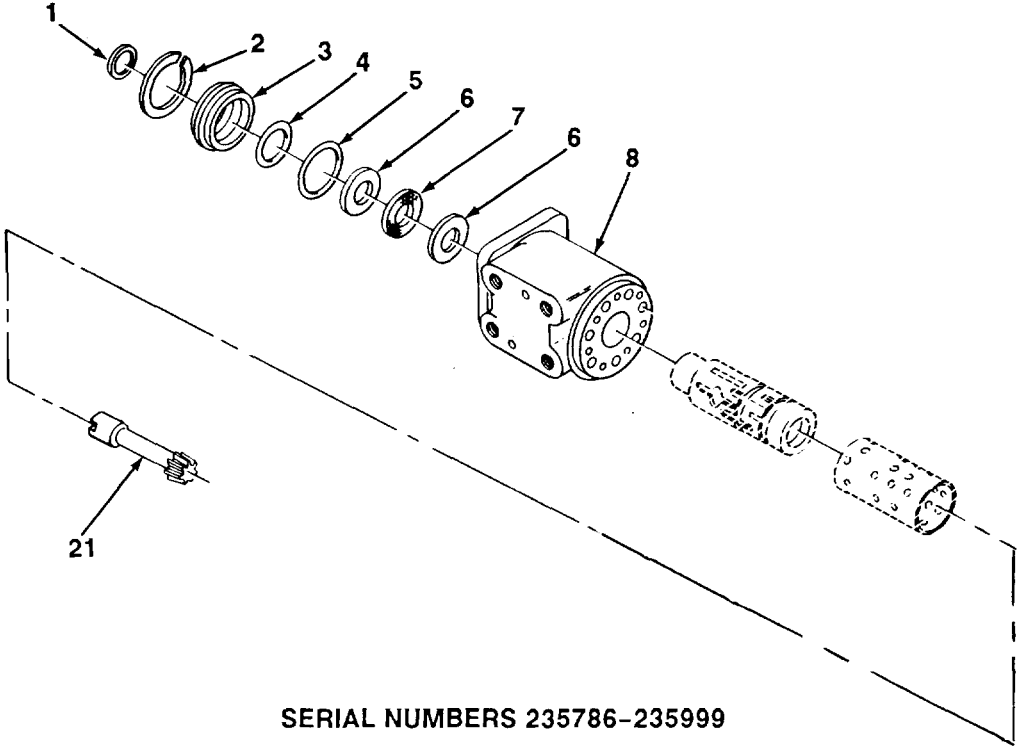

SERIAL NUMBERS 235786-235999

TA701488

11-3. STEERING VALVE ASSEMBLY MAINTENANCE.**NOTE**

Step 3 applies only to loader backhoes with serial numbers 235786-235999.

3. Install bearing ball (9), lockpin (10), and threaded insert (11) in valve housing (8).
4. Coat new preformed packing (5) with hydraulic fluid and install in packing retainer (3).
5. Install two bearing seats (6) and retainer and roller (7) in valve housing (8).
6. Coat new preformed packings (1 and 4) with hydraulic fluid. Install preformed packings on packing retainer (3).
7. Install packing retainer (3) in valve housing (8).
8. Using retaining ring pliers, install retaining ring (2) in valve housing (8).

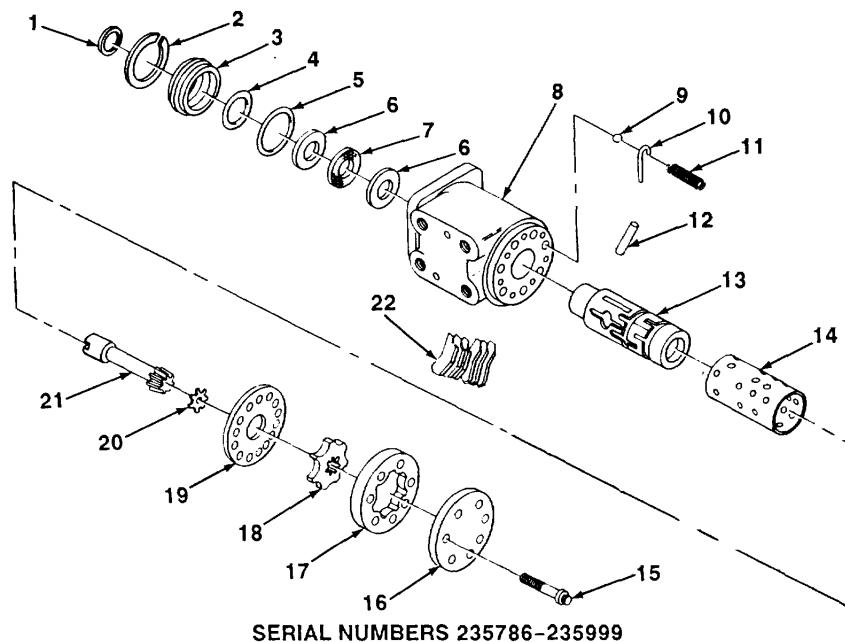
**NOTE**

Perform steps 9 through 13 only if valve housing, spool, or sleeve was replaced. Valve housing, spool, and sleeve are a matched set and must be replaced together.

9. Install spool (13) in sleeve (14) with spring slots at same end.
10. Coat spool (13) and sleeve (14) with hydraulic fluid.
11. Install six centering springs (22) in spool (13) and sleeve (14).
12. Install centering straight pin (12) in spool (13) and sleeve (14) until flush or below surface of sleeve.
13. Install assembled spool (13) and sleeve (14) in valve housing (8). Rotate spool and sleeve until seated in valve housing.

11-3. STEERING VALVE ASSEMBLY MAINTENANCE.

14. Position plate spacer (19) on valve housing (8) with holes alined.

NOTE

Step 15 applies only to loader backhoes with serial numbers 319995-342573.

15. Coat two new preformed packings (23) with hydraulic fluid and install on valve housing (8).
16. Position outer gear (17) in place on plate spacer (19) and valve housing (8) with holes alined.
17. Install drive shaft (21) in valve housing (8) with slotted end of drive shaft seated over centering straight pin (12).
18. Install inner gear (18) on drive shaft (21) and in outer gear (17). Valley in inner gear must be alined with centering straight pin (12).
19. Install sleeve spacer (20) on drive shaft (21) in inner gear (18).

NOTE

Step 20 applies only to loader backhoes with serial numbers 319995-342573.

20. Coat new preformed packing (23) with hydraulic fluid and install on outer gear (17).
21. Position cover (16) in place on outer gear (17) and valve housing (8) and secure with seven bolts (15). Torque bolts to 250 lb.-in. (28.3 N•m).

FOLLOW-ON TASKS:

- Install steering column and valve support (see paragraph 11-1).

TA701490

CHAPTER 12
FRAME MAINTENANCE

12-1. FRAME ASSEMBLY FRONT SUPPORT MAINTENANCE.

This Task Covers:

- | | |
|----------------------------|-----------------|
| a. Removal | d. Assembly |
| b. Disassembly | e. Installation |
| c. Cleaning and Inspection | |
-

Initial Setup:

Equipment Conditions:

- Loader bucket assembly removed (see TM 5-2420-222-20).
- Side grille springs removed (see TM 5-2420-222-20).
- Fuel tank removed (see TM 5-2420-222-20).
- Radiator removed (see TM 5-2420-222-20).
- Fuel shutoffvalve-to-fuel pump fuel line removed (see TM 5-2420-222-20).

Tools/Test Equipment:

- General mechanic's tool kit
- Field automotive shop set

References:

- TM 5-2420-222-20

Materials/Parts:

- Metal bonding adhesive (Item 1, Appendix B)
- Denatured alcohol (Item 2, Appendix B)
- Sealing compound (Item 11, Appendix B)
- Rags (Item 28, Appendix B)
- Dry cleaning solvent (Item 31, Appendix B)
- Marker tags (Item 32, Appendix B)
- One cotter pin
- Eight lockwashers

Personnel Required: Two

General Safety Instructions:

- Dry cleaning solvent is flammable and must not be used near open flame. Use only in a well-ventilated area.
 - Denatured alcohol is highly flammable and poisonous. Keep away from open flame and use only in a well-ventilated area.
-

12-1. FRAME ASSEMBLY FRONT SUPPORT MAINTENANCE (Con't).

a. REMOVAL**WARNING**

Use extreme caution when handling heavy parts. Lifting device is required when parts weigh over 50 lb (23 kg) for a single person lift, over 100 lb (45 kg) for a two person lift, and over 150 lb (68 kg) for a three or more person lift. Keep clear of heavy parts supported only by lifting device. Failure to follow this warning may cause serious injury or death to personnel.

1. Position lifting device in place over frame assembly front support (6).
2. Install sling through and under frame assembly front support (6). Connect ends of sling to lifting device.
3. Raise lifting device until it supports weight of frame assembly front support (6).
4. Remove hydraulic oil cooler-to-clutch control valve oil line (see TM 5-2420-222-20).
5. Remove clutch control valve-to-hydraulic pump inlet oil line (see TM 5-2420-222-20).
6. Remove hydraulic oil pump-to-pressure control valve oil line (see TM 5-2420-222-20).

NOTE

- **Tag all lines to ensure proper installation.**
- **Use a drain pan to catch fluid when disconnecting lines. Clean up all spills.**

7. Disconnect hydraulic oil drain line (2) from elbow (1).
8. Remove screw (3), lockwasher (4), clamp (5), and hydraulic oil drain line (2) from frame assembly front support (6). Discard lockwasher.
9. Disconnect hose (11) from line (10).
10. Disconnect hose (12) from line (9).
11. Disconnect hydraulic pump solenoid wire connector (7) from main wiring harness connector (8).

12-1. FRAME ASSEMBLY FRONT SUPPORT MAINTENANCE (Con't).

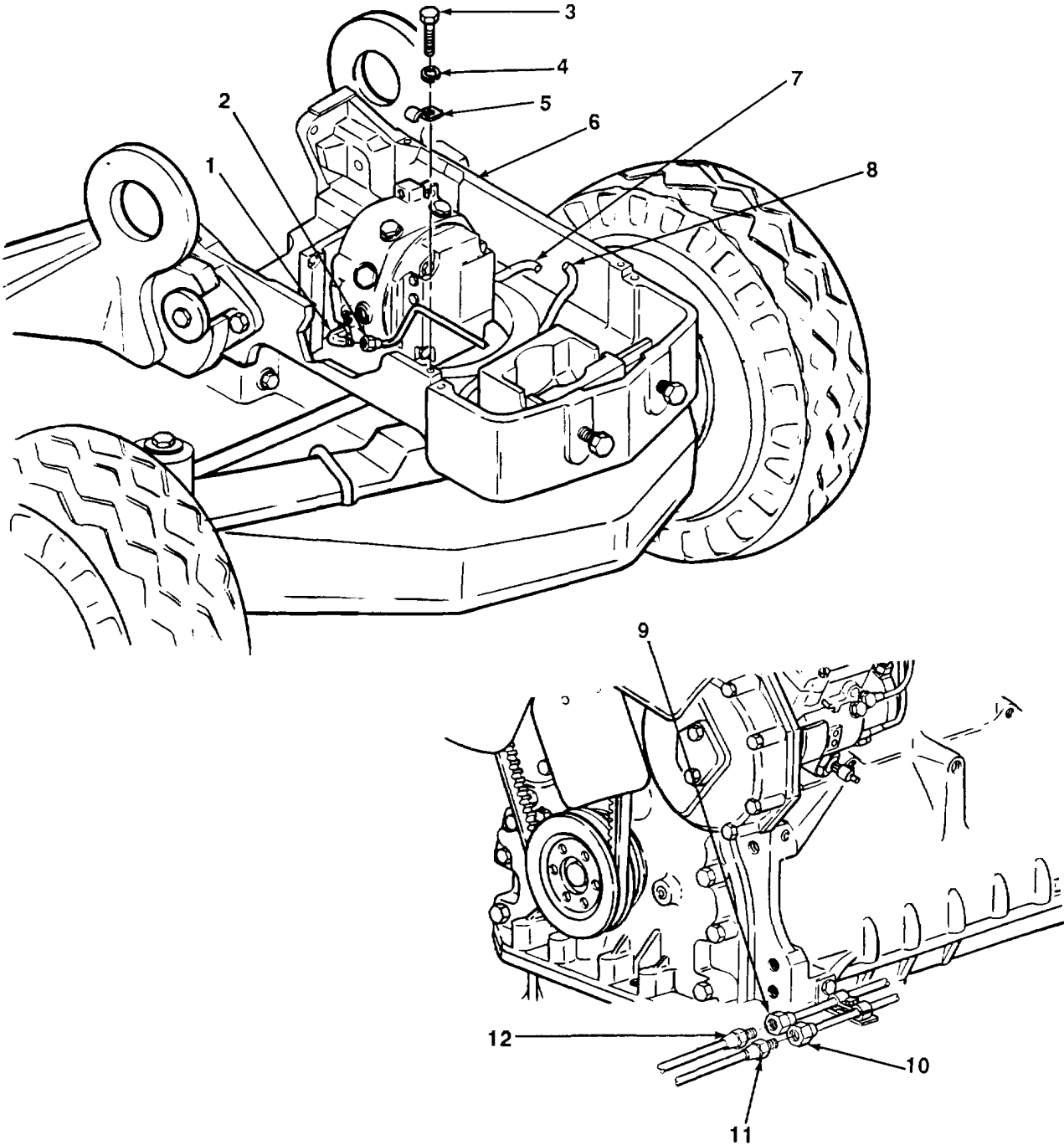

TA701491

12-1. FRAME ASSEMBLY FRONT SUPPORT MAINTENANCE (Con't).**NOTE**

Loader backhoes have two different types of hydraulic pump drive shaft connections. Perform steps 12 and 13 for loader backhoes with serial numbers 235786-235999. Perform steps 14 and 15 for loader backhoes with serial numbers 319995-342573.

12. Loosen two screws (14) in hydraulic pump drive shaft (17).
13. Remove two special nuts (16), screws (19), and half couplers (15 and 18) from four rubber sets (13) on hydraulic pump drive shaft (17).

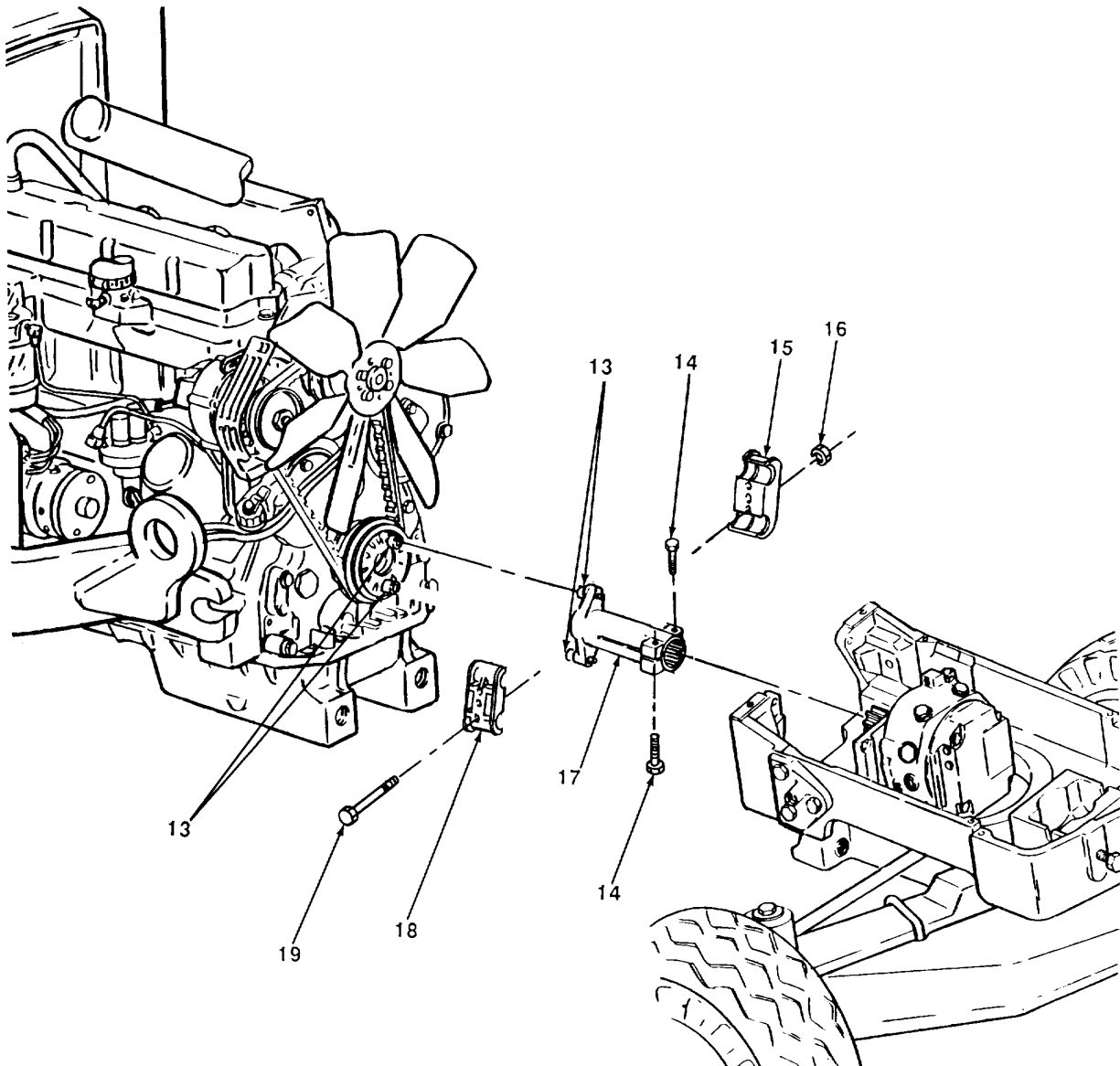

SERIAL NUMBERS 235786-235999

TA701492

12-1. FRAME ASSEMBLY FRONT SUPPORT MAINTENANCE (Con't).

14. Remove four screws (21) from hydraulic pump drive shaft (17).
15. Remove two screws (20), coupling front half (23), cushion (24), and hydraulic pump drive shaft (17) from hydraulic pump shaft (22).

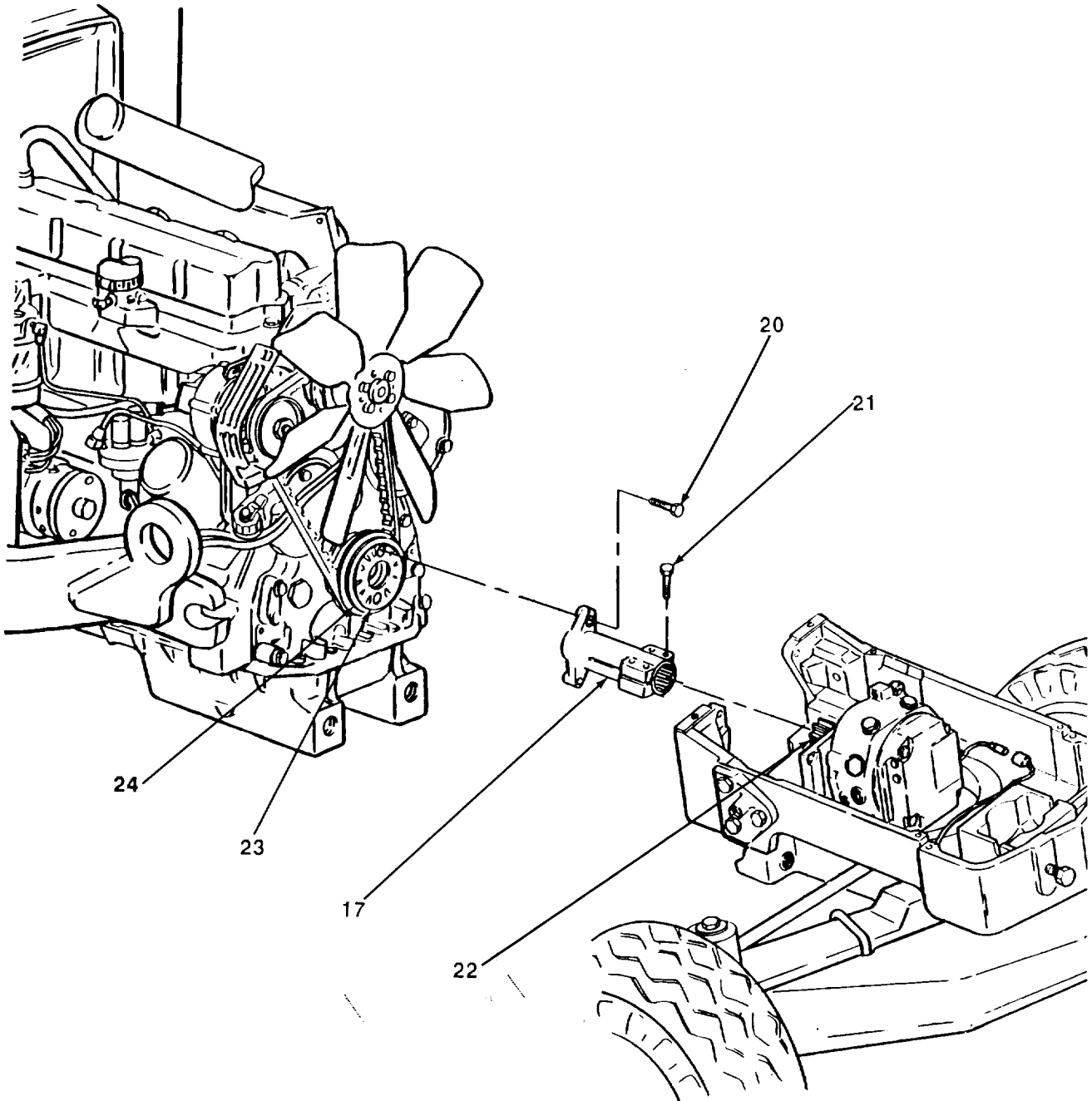

Serial numbers 319995-342573

TA701493

12-1. FRAME ASSEMBLY FRONT SUPPORT MAINTENANCE (Con't).

16. Position wood blocks under engine assembly (25) and under rear of loader backhoe boom.
17. Position two 5 ton jackstands under left and right side frames (33).
18. Remove two capscrews (28) and lockwashers (29) from engine assembly oil pan (32) and frame assembly front support (6). Discard lockwashers.
19. Remove four capscrews (27) and lockwashers (26) from frame assembly front support (6) and engine assembly (25). Discard lockwashers.
20. Remove two capscrews (36), lockwashers (35), and washers (34) from left and right side frames (33) and siderail mountings (31). Discard lockwashers.

CAUTION

**Ensure that hydraulic and steering lines and hoses are clear before separation.
Failure to do so may damage parts.**

21. Using lifting device and the aid of two assistants, roll frame assembly front support (6) and front axle (30) away from engine assembly (25) and left and right side frames (33).
22. Position wood blocks under frame assembly front support (6). Lower lifting device until frame assembly front support rests on wood blocks. Place wood blocks in front of and behind tires to prevent movement.

12-1. FRAME ASSEMBLY FRONT SUPPORT MAINTENANCE (Con't).

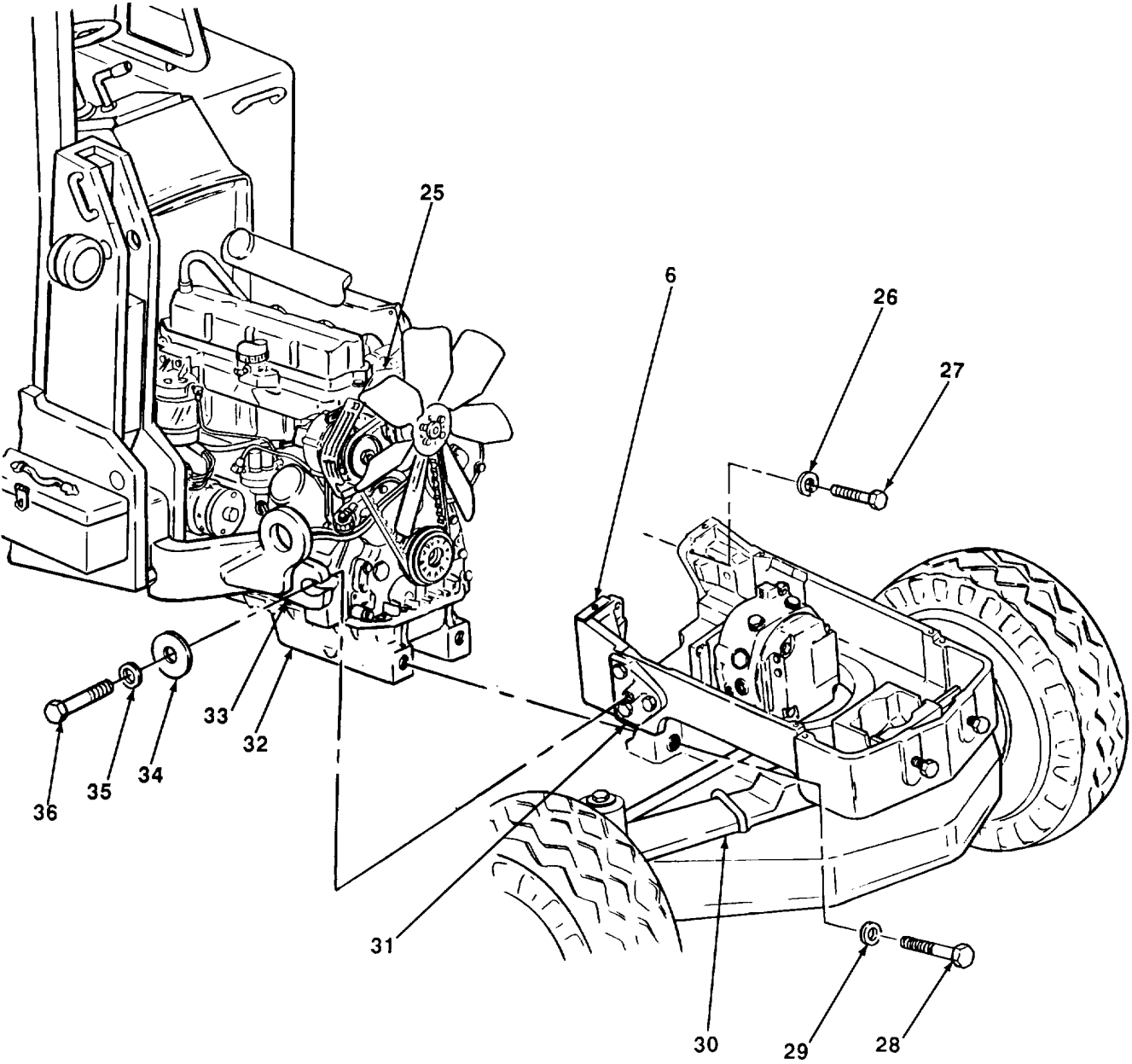

12-1. FRAME ASSEMBLY FRONT SUPPORT MAINTENANCE (Con't).

23. Pry spacers (49) out of engine assembly oil pan (32).

NOTE

If frame assembly front support is being removed only to access engine assembly for removal, skip steps 24 through 32.

24. Pry hydraulic pump drive shaft (17) off hydraulic pump (37).
25. Remove four screws (38) and hydraulic pump (37) from frame assembly front support (6).
26. If damaged, remove grease fittings (43 and 48) from pivot pin (47) and front axle (30).
27. Raise lifting device and support frame assembly front support (6) in a horizontal position. Position wood blocks under front axle (30) and tires for support and to prevent movement.
28. Drive out pivot pin (47) from front axle (30) and frame assembly front support (6).
29. Remove cotter pin (39) from slotted nut (40) and screw (45). Discard cotter pin.

NOTE

Record size and quantity of shims to ensure proper installation.

30. Remove slotted nut (40), washer (41), shims (42), screw (45), and washer (46) from front axle (30), frame assembly front support (6), and pivot pin (44).

12-1. FRAME ASSEMBLY FRONT SUPPORT MAINTENANCE (Con't).

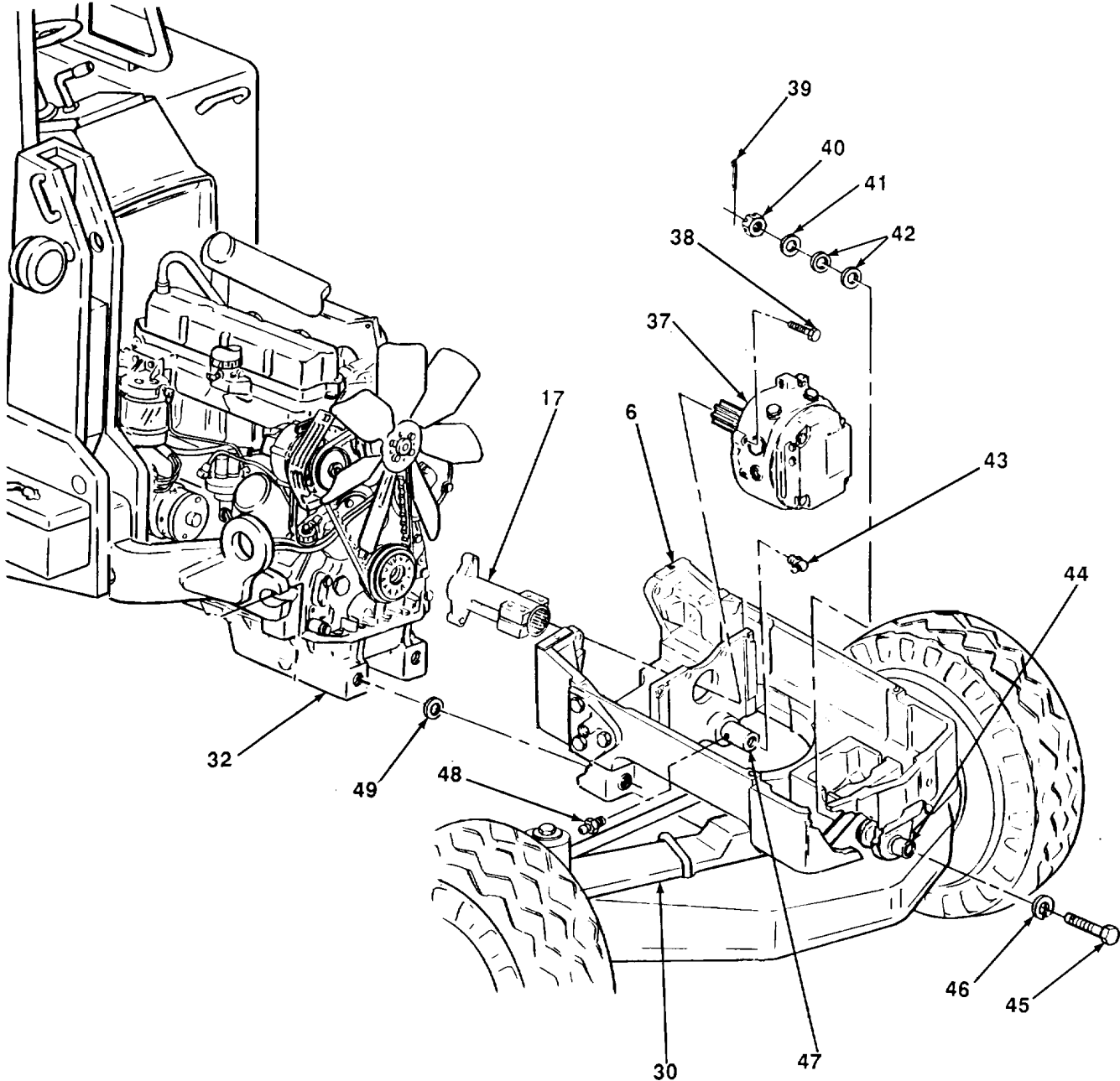

TA701495

12-1. FRAME ASSEMBLY FRONT SUPPORT MAINTENANCE (Con't).

31. Remove pivot pin (44) out of front axle (30) and bushing (55).
32. Raise lifting device until frame assembly front support (6) is free of front axle (30). Move frame assembly front support away from front axle and lower onto wood blocks.

b. DISASSEMBLY**CAUTION**

Do not remove grease fitting, bushing, hollow dowel pins, or spring pins unless damaged. Removal may damage parts.

1. Remove grease fitting (56) from frame assembly front support (6).
2. Drive bushing (55) out of frame assembly front support (6).
3. Remove two hollow dowel pins (50) and four spring pins (54) from frame assembly front support (6).

WARNING

Dry cleaning solvent, P-D-680, is toxic and flammable. Always wear protective goggles and gloves, and use only in a well-ventilated area. Avoid contact with skin, eyes, and clothes, and DO NOT breathe vapors. DO NOT use near open flame or excessive heat. The solvent's flash point is 100°F-138°F (38°C-59°C). If you become dizzy while using cleaning solvent, immediately get fresh air and medical help. If solvent contacts eyes, immediately wash your eyes and get medical aid.

CAUTION

Do not remove baffles and strip packings unless damaged. Removal may damage

4. Using dry cleaning solvent, dissolve adhesive and remove four baffles (53) and two strip packings (57). Rinse and dry frame assembly front support (6).

NOTE

Frame assembly front support has two siderail mountings that are removed the same way. Right side is shown. Repeat steps 5 and 6 for left side.

5. Remove two nuts (52), washers (51), and screws (60) from siderail mounting (31) and frame assembly front support (6).
6. Remove screw (59), washer (58), and siderail mounting (31) from frame assembly front support (6).
7. Remove identification plate (see TM 5-2420-222-20).

c. CLEANING AND INSPECTION**WARNING**

Denatured alcohol is highly flammable and poisonous. Drinking this alcohol can cause blindness and death. Avoid inhaling its fumes. Keep away from open flame. Failure to follow this warning may cause serious injury or death to personnel.

1. Using denatured alcohol and clean rags, clean spacers and frame assembly front support. Wipe dry with clean, dry rags.

12-1. FRAME ASSEMBLY FRONT SUPPORT MAINTENANCE (Con't).

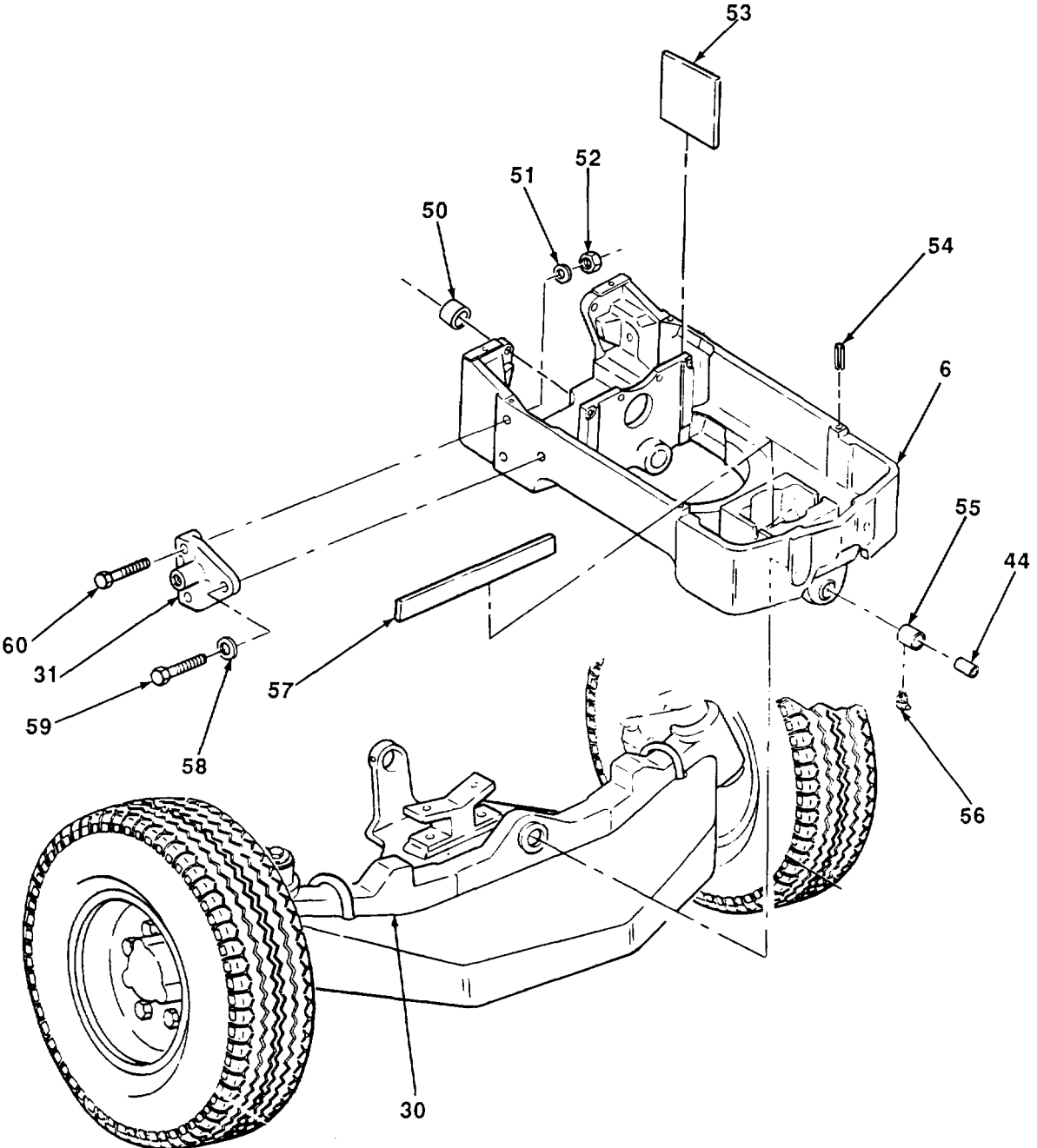

TA701496

12-1. FRAME ASSEMBLY FRONT SUPPORT MAINTENANCE (Con't).**WARNING**

Dry cleaning solvent, P-D-680, is toxic and flammable. Always wear protective goggles and gloves, and use only in a well-ventilated area. Avoid contact with skin, eyes, and clothes, and DO NOT breathe vapors. DO NOT use near open flame or excessive heat. The solvent's flash point is 100°F-138°F (38°C-59°C). If you become dizzy while using cleaning solvent, immediately get fresh air and medical help. If solvent contacts eyes, immediately wash your eyes and get medical aid.

2. Clean all other metal parts with dry cleaning solvent. Wipe dry with clean, dry rags.
3. Inspect four baffles and strip packings for rips and tears. Replace as required.
4. Inspect all metal parts for cracks, bends, or breaks. Replace as required.
5. Inspect frame assembly front support, two siderail mountings, and pivot pins for damaged threads. Restore damaged threads with screw threading set.

d. ASSEMBLY

1. Install identification plate (see TM 5-2420-222-20).

NOTE

Frame assembly front support has two siderail mountings that are installed the same way. Right side is shown. Repeat steps 2 and 3 for left side.

2. Position siderail mounting (31) on frame assembly front support (6) and install screw (59) and washer (58).
3. Install two screws (60), washers (51), and nuts (52) through siderail mounting (31) and frame assembly front support (6). Torque screws (59 and 60) to 240 lb.-ft. (325 N•m).

NOTE

Perform steps 4 and 5 only if baffles or strip packings were removed.

4. Apply metal bonding adhesive to back of four baffles (53) or two strip packings (57). Position in place on frame assembly front support (6), then remove and allow metal bonding adhesive to set for two minutes.
5. Position baffles (53) or strip packings (57) on frame assembly front support (6) and press firmly in place.
6. If removed, install four spring pins (54) and two hollow dowels (50) in frame assembly front support (6).
7. If removed, use remover and installer to install bushing (55) in frame assembly front support (6) with grease holes aligned.
8. If removed, install grease fitting (56) in frame assembly front support (6).

12-1. FRAME ASSEMBLY FRONT SUPPORT MAINTENANCE (Con't).

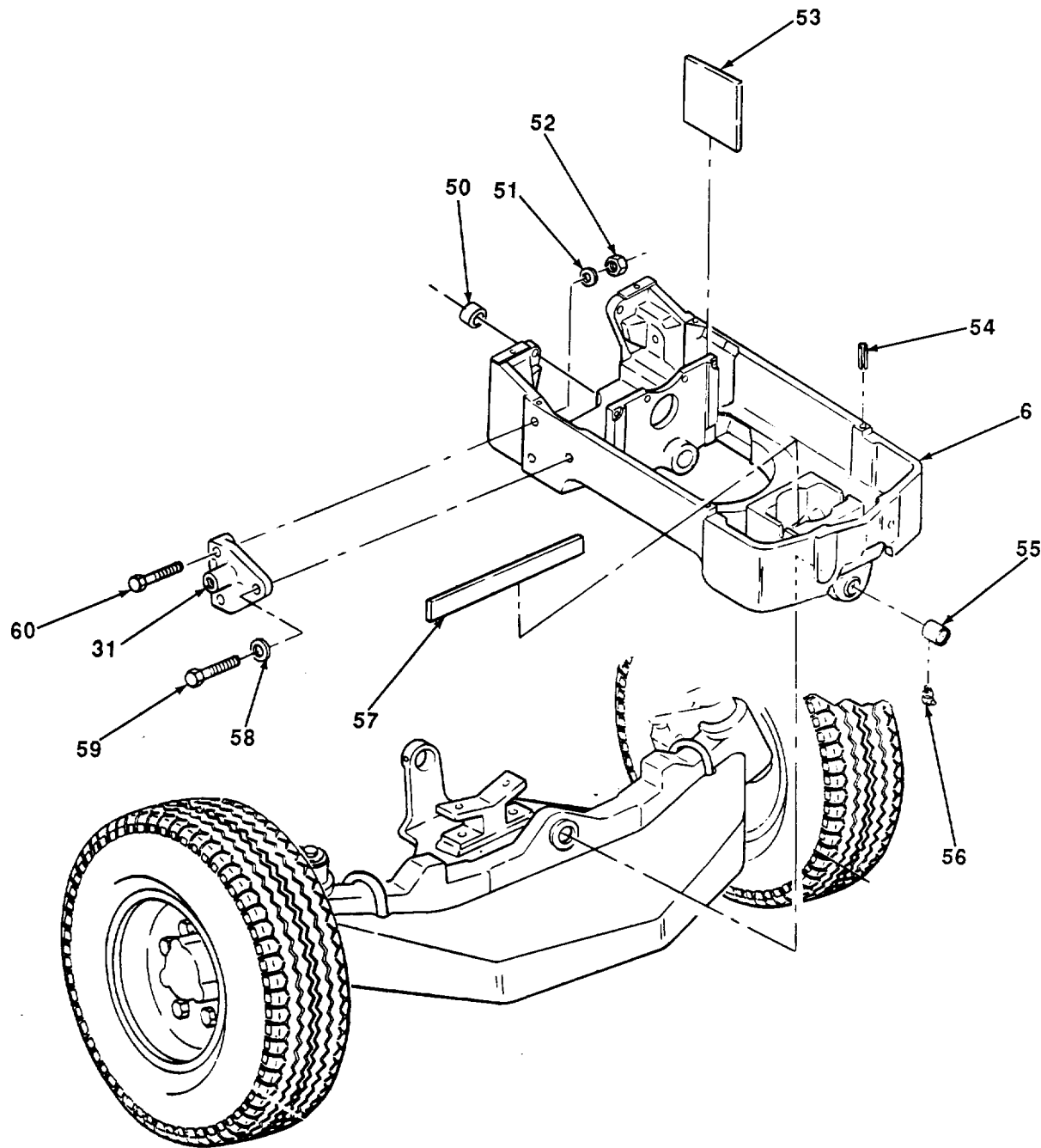

TA701497

12-1. FRAME ASSEMBLY FRONT SUPPORT MAINTENANCE (Con't).**e. INSTALLATION****WARNING**

Use extreme caution when handling heavy parts. Lifting device is required when parts weigh over 50 lb (23 kg) for a single person lift, over 100 lb (45 kg) for a two person lift, and over 150 lb (68 kg) for a three or more person lift. Keep clear of heavy parts supported only by lifting device. Failure to follow this warning may cause serious injury or death to personnel.

NOTE

If frame assembly front support was removed only to access engine for removal, skip steps 1 through 11.

1. Using a lifting device and the aid of an assistant, lift frame assembly front support (6) and position on front axle (30) with pin holes aligned.
2. Drive pivot pin (47) in pin holes of frame assembly front support (6) and front axle (30). If removed, install grease fitting (43) in pivot pin.
3. If removed, install grease fitting (48) in front axle (30).
4. Install pivot pin (44) in busting (55) and front axle (30).

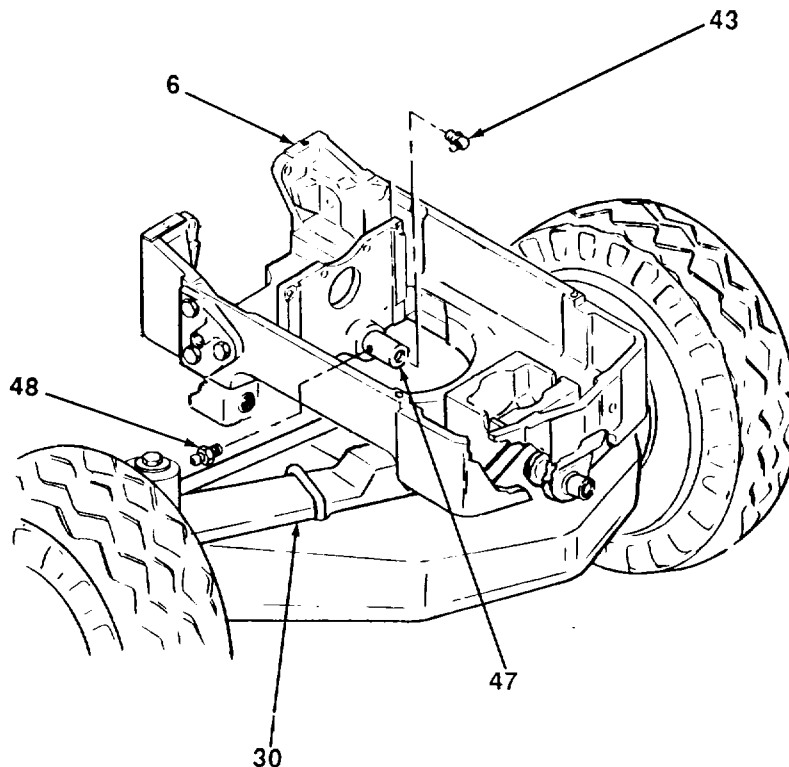

TA701498

12-1. FRAME ASSEMBLY FRONT SUPPORT MAINTENANCE (Con't).

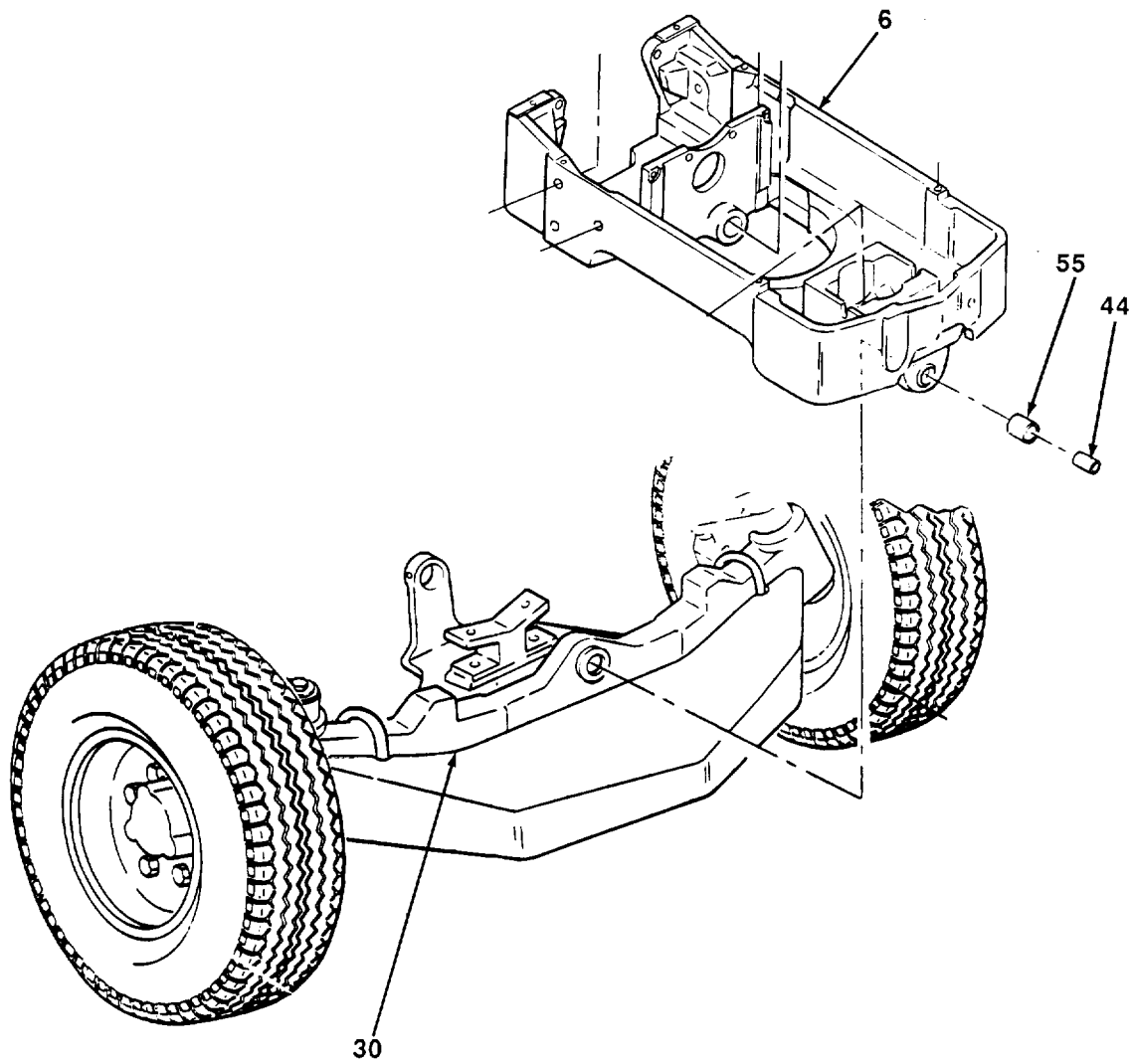

TA701499

12-1. FRAME ASSEMBLY FRONT SUPPORT MAINTENANCE (Con't).

5. Position wood blocks in place between front axle (30) and frame assembly front support (6).
6. Install screw (45), washer (46), and slotted nut (40) in frame assembly front support (6), front axle (30), and pivot pin (44). Tighten screw and nut until front axle is drawn tight against frame assembly front support.
7. Remove slotted nut (40) from screw (45). Install shims (42) on screw as noted during removal. Install washer (41) and slotted nut on screw. Torque nut and screw to 240 lb.-ft. (325 N•m)
8. Using thickness gage, check clearance between washer (41) and front axle (30). Clearance must be 0.000-0.015 in. (0.000-0.381 mm). If clearance exceeds specification, repeat steps 7 and 8 and remove one shim (42).
9. With the aid of an assistant, tighten screw (45) and slotted nut (40) until cotter pin slot lines up with hole in screw. Install new cotter pin (39) in screw and slotted nut.
10. Position hydraulic pump (37) in place on frame assembly front support (6). Install four screws (38) in hydraulic pump and frame assembly front support. Torque screws to 85 lb.-ft. (115 N•m).
11. Install hydraulic pump drive shaft (17) in place on hydraulic pump (37).

CAUTION

Ensure that mating surfaces of engine block, engine assembly oil pan, and frame assembly front support have been properly cleaned before sealing compound is applied. Dirty surfaces may prevent sealing compound from sticking, causing improper fit and damage to parts. Ensure that no sealing compound gets in screw holes. This will cause false torque readings which may damage parts.

12. Apply sealing compound to all mating surfaces between frame assembly front support (6), engine assembly (25), and engine assembly oil pan (32).
13. Remove wood blocks from front tires.

12-1. FRAME ASSEMBLY FRONT SUPPORT MAINTENANCE (Con't).

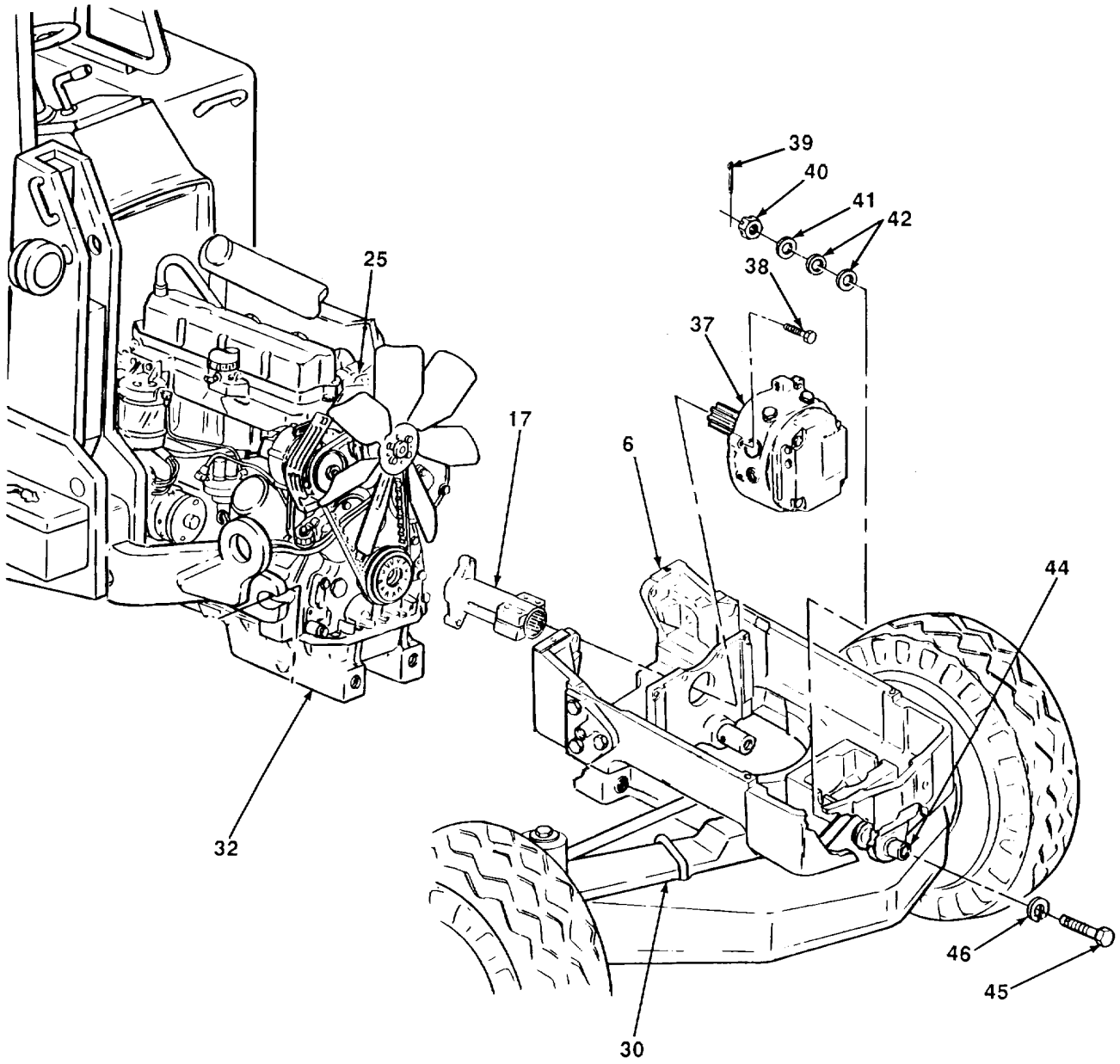

TA701500

12-1. FRAME ASSEMBLY FRONT SUPPORT MAINTENANCE (Con't).

CAUTION

Ensure that hydraulic and steering lines are clear before installing frame assembly front support. Failure to do so may damage parts.

14. Using lifting device and the aid of two assistants, raise frame assembly front support (6) off wood blocks and roll into position against engine assembly oil pan (32), engine assembly (25), and left and right side frames (33). Ensure that screw holes are aligned.
15. Loosely install two capscrews (28) and new lockwashers (29) in engine assembly oil pan (32), frame assembly front support (6), and engine assembly (25). Loosely install four capscrews (27) and new lockwashers (26) in frame assembly front support and engine assembly.
16. Tighten two capscrews (28) in frame assembly front support (6) and engine assembly oil pan (32).
17. Tighten four capscrews (27) in frame assembly front support (6) and engine assembly (25). Torque capscrews to 170 lb.-ft. (231 N•m).
18. Install two capscrews (36), washers (34), and new lockwashers (35) through siderail mountings (31) and left and right side frames (33). Torque capscrews to 250 lb.-ft. (339 N•m).
19. Remove two capscrews (28) and lockwashers (29) from frame assembly front support (6) and engine assembly oil pan (32).
20. Remove wood blocks from under engine assembly (25) and rear of loader backhoe boom.
21. Remove two 5 ton jackstands from under left and right loader backhoe side frames (33).
22. Lower lifting device and remove sling from frame assembly front support (6).

12-1. FRAME ASSEMBLY FRONT SUPPORT MAINTENANCE (Con't).

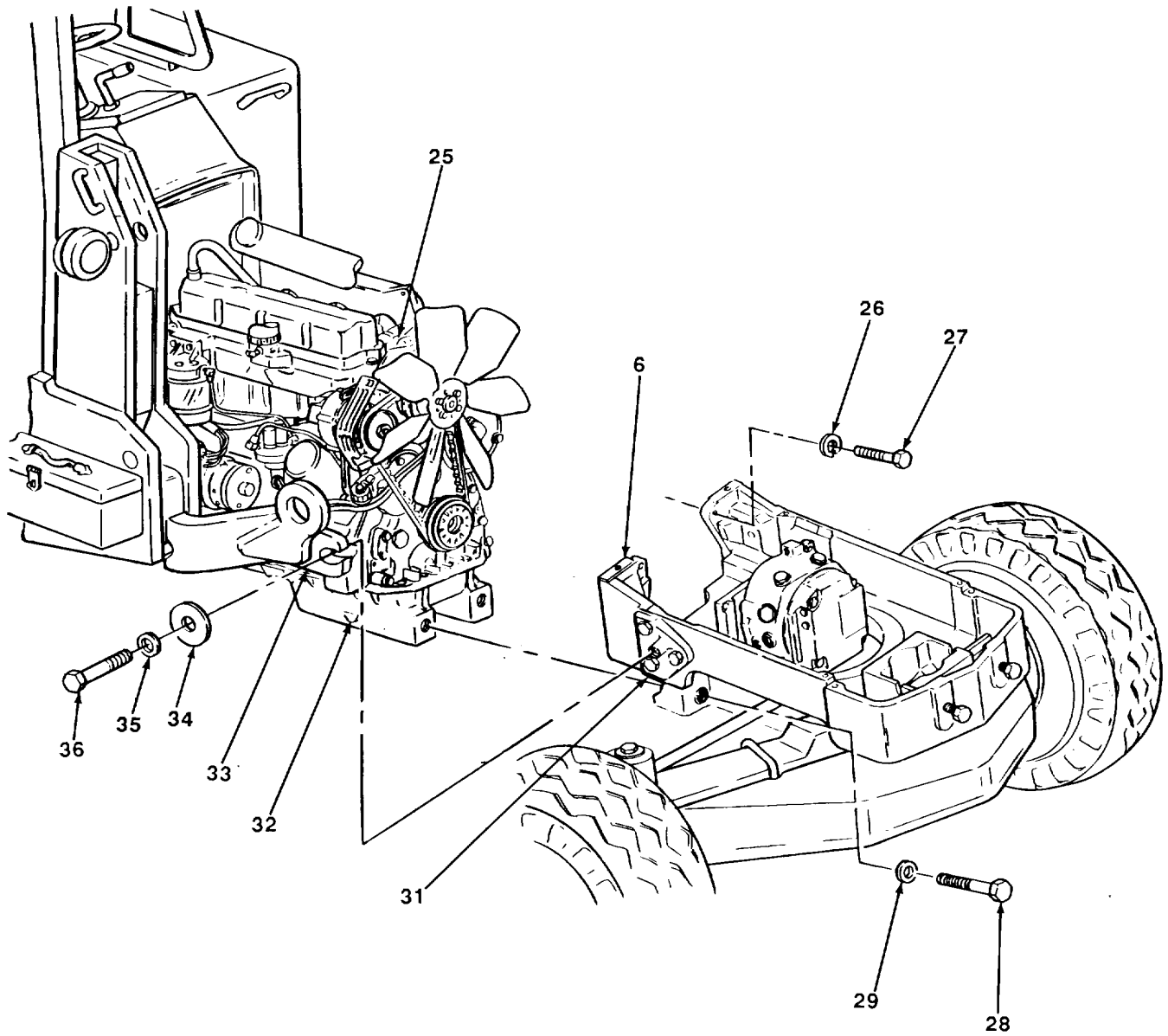

TA701501

12-1. FRAME ASSEMBLY FRONT SUPPORT MAINTENANCE (Con't).**NOTE**

There are spacers on both sides of engine assembly oil pan. Installation and clearance measurements are the same for both sides. Right side is shown. Repeat steps 23 through 27 for left side.

23. Position spacer (49) in place between frame assembly front support (6) and engine assembly oil pan (32).
24. Measure distance from face of spacer (49) to frame assembly front support (6) with thickness gage. Measurement must be 0.000-0.001 in. (0.000-0.025 mm).

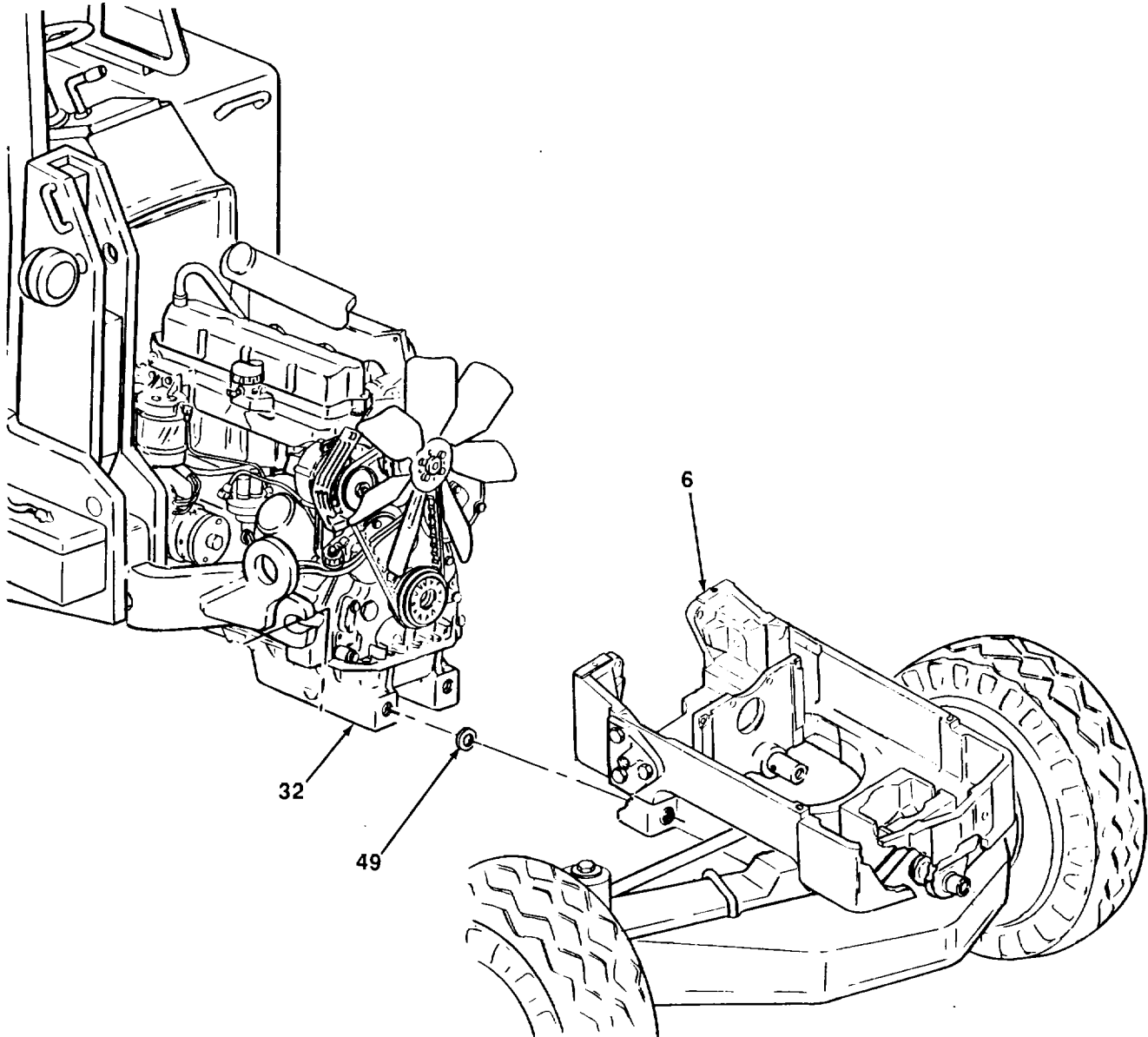

TA701502

12-1. FRAME ASSEMBLY FRONT SUPPORT MAINTENANCE (Con't).

25. If measurement exceeds specification for either left or right side, add one spacer (49) and repeat steps 23 and 24. If not, go to step 26.
26. Apply sealing compound to flat surface of spacer (49) and position in place against engine assembly oil pan (32).
27. Install two capscrews (28) and lockwashers (29) through frame assembly front support (6), spacers (49), and engine assembly oil pan (32). Torque capscrews to 300 lb.-ft. (407 N•m).

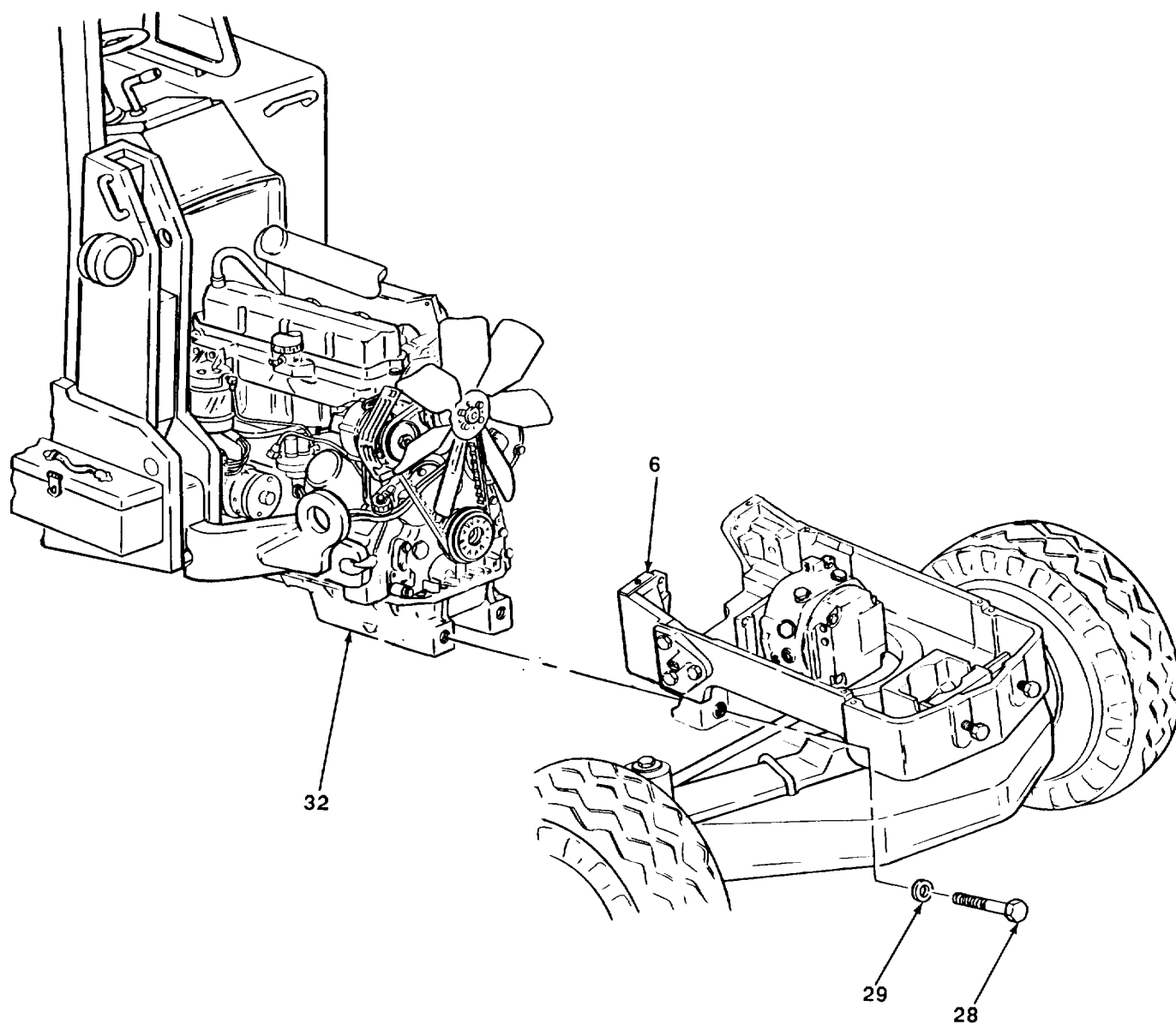

TA701503

12-1. FRAME ASSEMBLY FRONT SUPPORT MAINTENANCE (Con't).

NOTE

Loader backhoes have two different types of hydraulic pump drive shaft connections. Perform steps 28 through 33 for loader backhoes with serial numbers 319995-342573. Perform steps 34 through 36 for loader backhoes with serial numbers 235786-235999.

28. Position coupling front half (23) and cushion (24) in place against rear coupling half with teeth of cushion and rear coupling half engaged.
29. Using pinch bar, slide hydraulic pump drive shaft (17) on hydraulic pump shaft (22) until it is against front coupling half (23) with screw holes aligned.
30. Install and tighten two screws (20) in hydraulic pump drive shaft (17) and coupling front half (23). Torque screws to 32-38 lb.-ft. (43-52 N•m).

CAUTION

Do not overtighten C-clamp holding coupling halves together or parts may be misaligned causing vibration damage.

31. Using 4 in. C-clamp, clamp coupling front half (23) and rear coupling half to crankshaft pulley just tight enough to keep them in place.
32. Apply sealing compound to four screws (21). Install screws in hydraulic pump drive shaft (17). Torque screws to 32-38 lb.-ft. (43-52 N•m).
33. Remove C-clamp from crankshaft pulley, coupling front half (23), and rear coupling half.

12-1. FRAME ASSEMBLY FRONT SUPPORT MAINTENANCE (Con't).

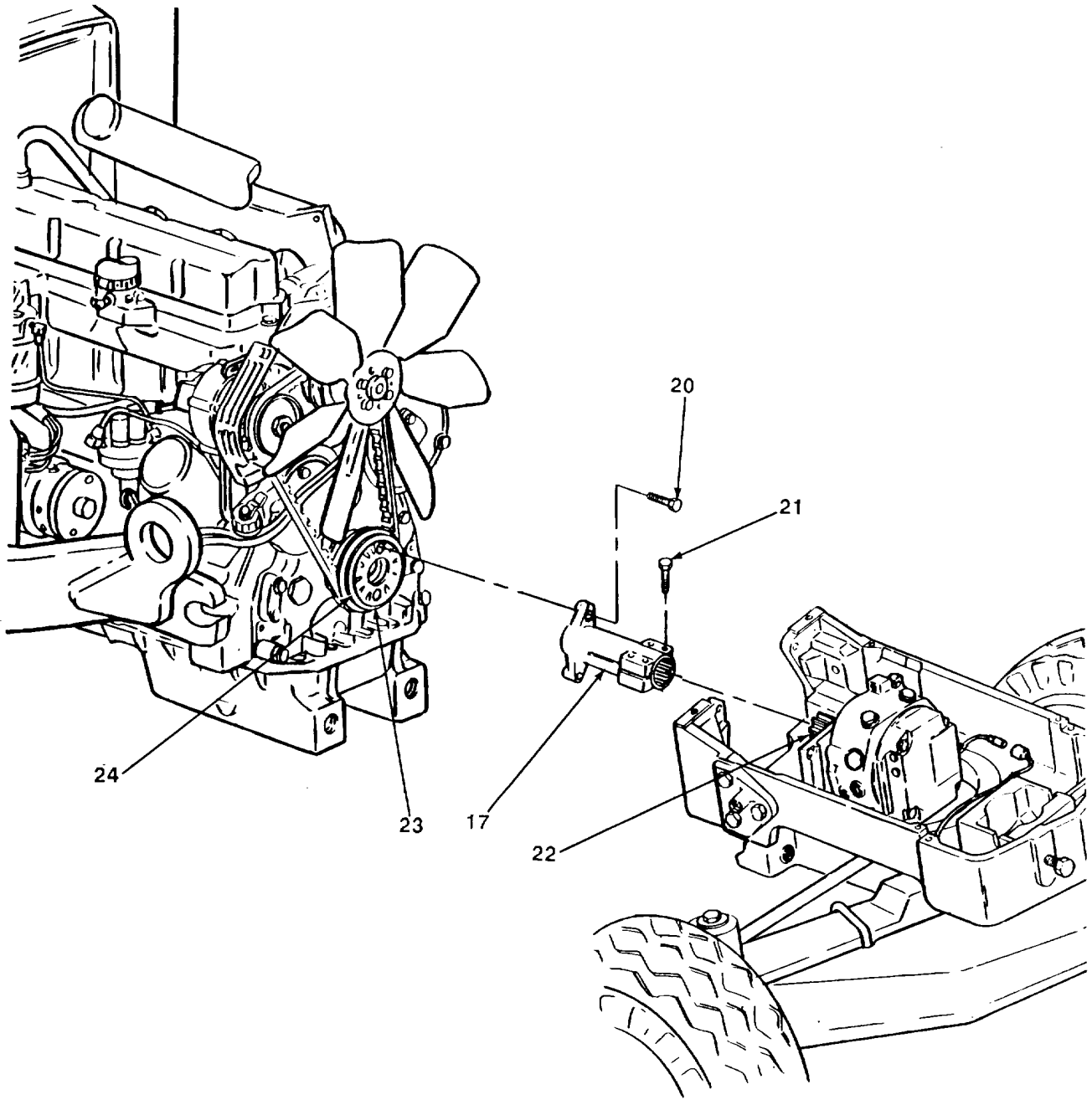

TA701504

SERIAL NUMBERS 31995-342573

12-1. FRAME ASSEMBLY FRONT SUPPORT MAINTENANCE (Con't).

NOTE

Rubber sets should seat in channels of half couplers with no metal-to-metal contact.

34. Position two half couplers (15 and 18) on four rubber sets (13). Install and alternately tighten two screws (19) in coupler halves. Torque screws to 23-27 lb.-ft. (31-37 N•m).
35. Install and alternately tighten two special nuts (16) on screws (19). Torque special nuts to 23-27 lb.-ft. (31-37 N•m).
36. Alternately tighten two screws (14) in hydraulic pump drive shaft (17). Torque screws to 23-27 lb.-ft. (32-37 N•m).

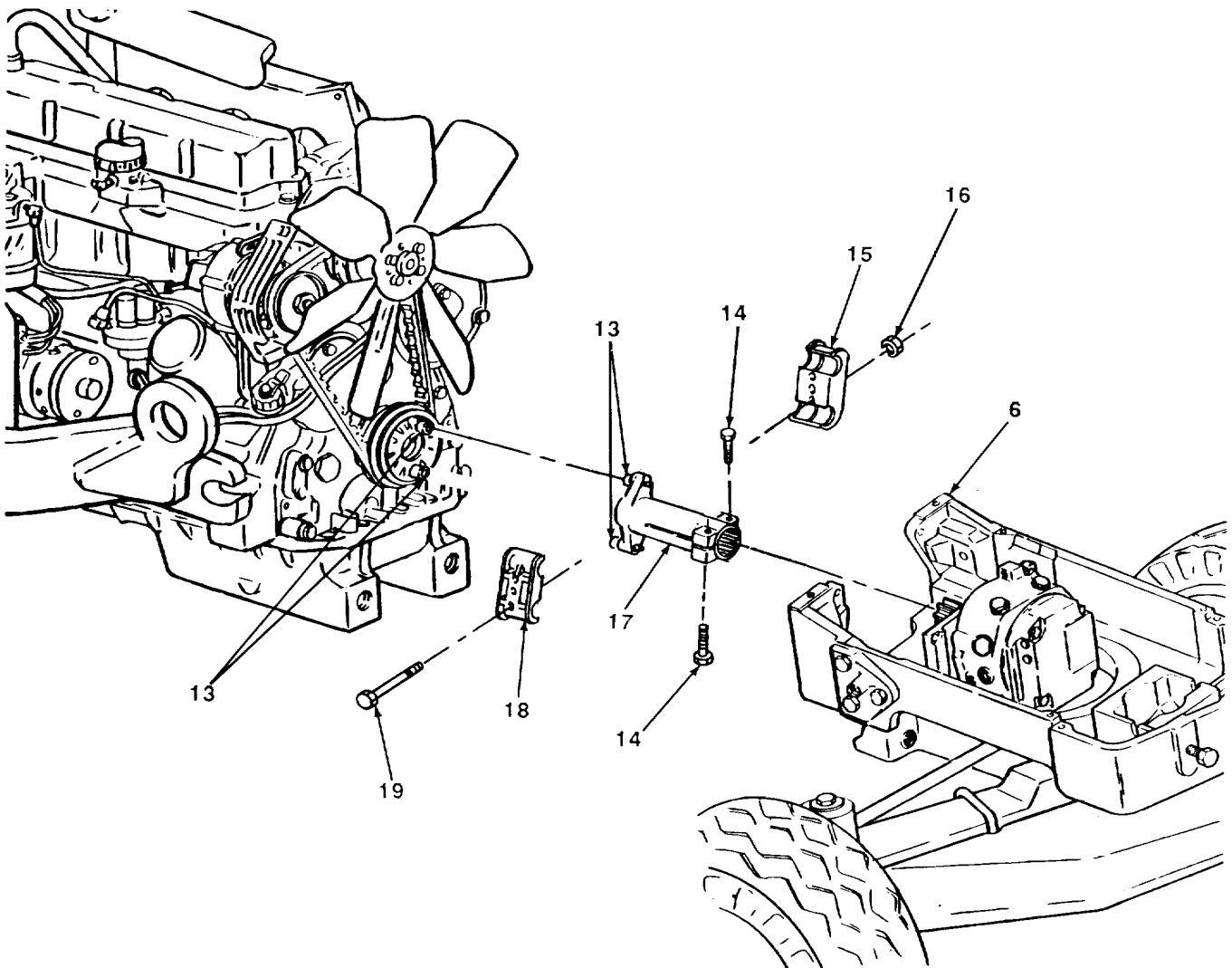

TA701505

SERIAL NUMBERS 235786-235999

12-1. FRAME ASSEMBLY FRONT SUPPORT MAINTENANCE (Con't).

37. Connect hydraulic pump solenoid wire connector (7) to main wiring harness connector (8).
38. Remove wood blocks from between frame assembly front support (6) and front axle.

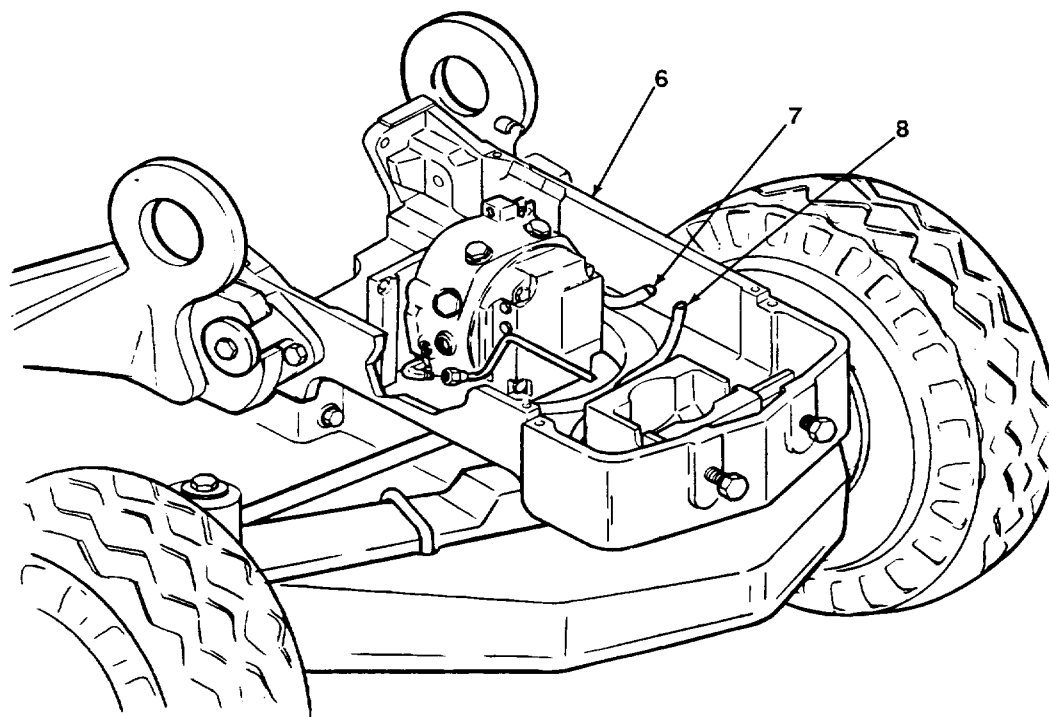

TA701506

12-1. FRAME ASSEMBLY FRONT SUPPORT MAINTENANCE (Con't).

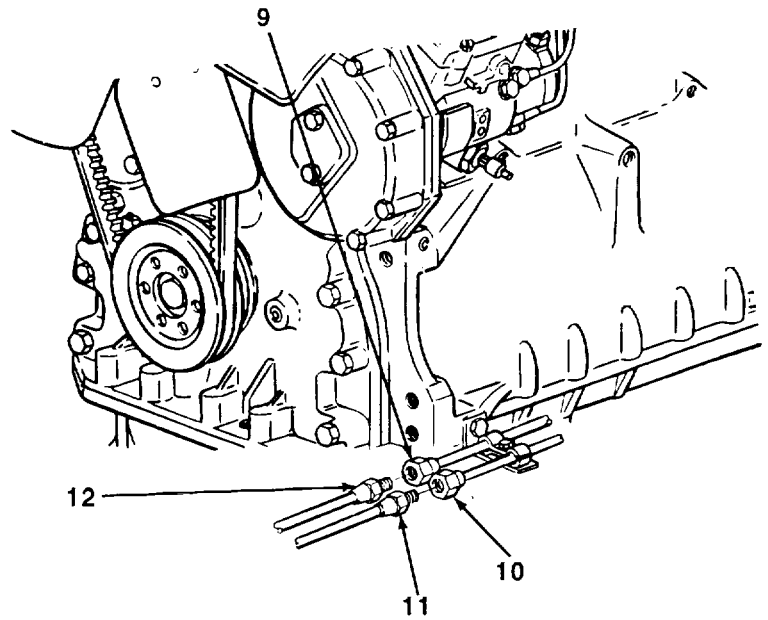
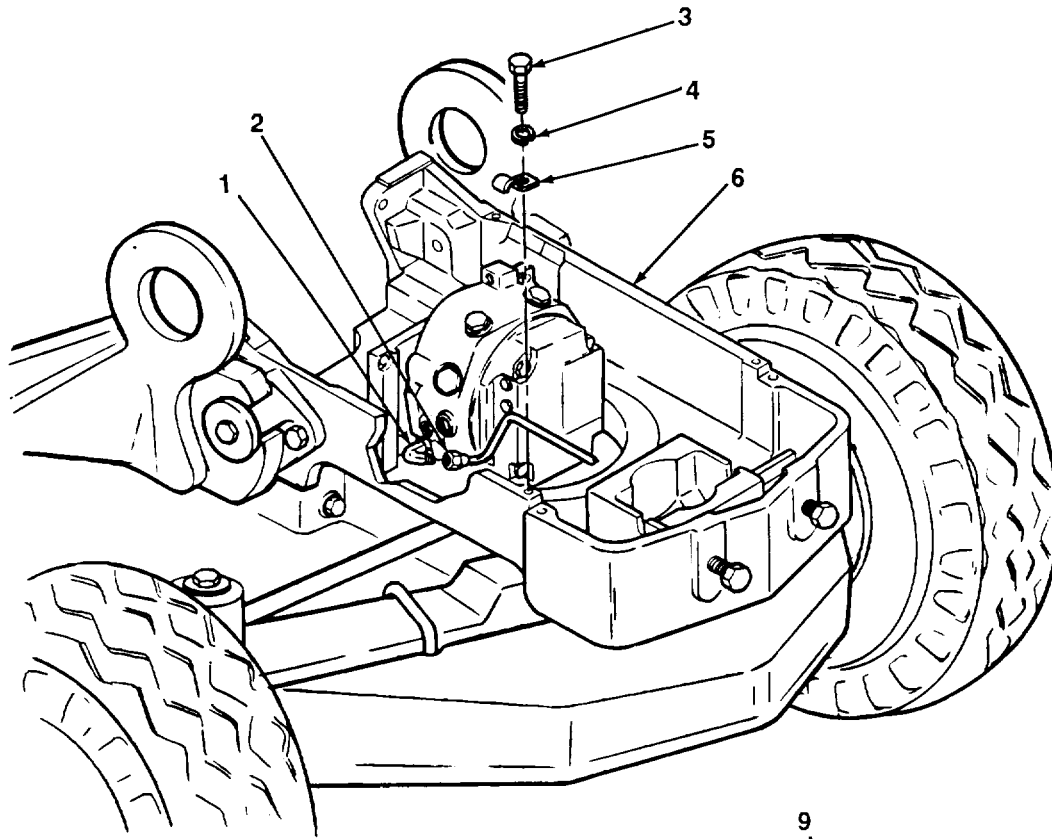

TA701507

12-1. FRAME ASSEMBLY FRONT SUPPORT MAINTENANCE (Con't).

39. Connect hose (11) to line (10).
40. Connect hose (12) to line (9).
41. Position hydraulic oil drain line (2) in place on frame assembly front support (6) and install clamp (5), screw (3), and new lockwasher (4).
42. Connect hydraulic oil drain line (2) to elbow (1).
43. Install hydraulic oil pump-to-pressure control valve oil line (see TM 5-2420-222-20).
44. Install clutch control valve-to-hydraulic pump Inlet oil line (see TM 5-2420-222-20).
45. Install hydraulic oil cooler-to-clutch control valve oil line (see TM 5-2420-222-20).

FOLLOW-ON TASKS:

- Install fuel shutoff valve-to-fuel pump fuel line (see TM 5-2420-222-20).
- Install radiator (see TM 5-2420-222-20).
- Install fuel tank (see TM 5-2420-222-20).
- Install side grille springs (see TM 5-2420-222-20).
- Install loader bucket assembly (see TM 5-2420-222-20).

12-27/(12-28 Blank)

**CHAPTER 13
BODY AND ACCESSORIES MAINTENANCE**

Paragraph Number	Paragraph Title	Page Number
13-1	Roll-over Protective Structure or Canopy Front Mounts and Brackets Maintenance	13-1
13-2	Canopy Protective Roof Maintenance (Serial Numbers 235786-235999)	13-7
13-3	Canopy Protective Roof Maintenance (Serial Numbers 319995-342573)	13-10
13-4	Roll-over Protective Structure or Canopy Rear Mounts Maintenance.....	13-13
13-5	Cowl Support Maintenance	13-25
13-6	Fenders and Supports Maintenance	13-32

13-1. ROLL-OVER PROTECTIVE STRUCTURE OR CANOPY FRONT MOUNTS AND BRACKETS MAINTENANCE.

This Task Covers:

- | | |
|--|---|
| <ul style="list-style-type: none"> a. Removal b. Disassembly c. Cleaning and Inspection | <ul style="list-style-type: none"> d. Repair e. Assembly f. Installation |
|--|---|

Initial Setup:

Equipment Conditions:

- Right inner platform removed (see TM 5-2420-222-20).
- Left outer platform removed (see TM 5-2420-222-20).

Tools/Test Equipment:

- General mechanic's tool kit
- Field automotive shop set

Materials/Parts:

- Detergent (Item 13, Appendix B)
- Rags (Item 28, Appendix B)
- Dry cleaning solvent (Item 31, appendix B)
- Eleven lockwashers

NOTE

Perform the following only when removing right front mounts.

- Accumulator removed (see TM 5-2420-222-20)
- Right platform removed (see TM 5-2420-222-20).

Personnel Required: Two

NOTE

Perform the following only when removing left front mounts. General Safety Instructions:

- | | |
|---|---|
| <ul style="list-style-type: none"> • Left platform removed (see TM 5-2420-222-20). | <ul style="list-style-type: none"> • Dry cleaning solvent is flammable and must not be used near open flame. Use only in a well-ventilated area. |
|---|---|

13-1. ROLL-OVER PROTECTIVE STRUCTURE OR CANOPY FRONT MOUNTS AND BRACKETS MAINTENANCE (Con't).

NOTE

- Loader backhoes with serial numbers 235786-235999 have a canopy. Loader backhoes with serial numbers 319995-342573 have a roll-over protective structure (ROPS).
- Both front mounts and brackets for canopy or ROPS are maintained the same way. Left side is shown. Repeat procedure for right side as required.

a. REMOVAL

WARNING

Use extreme caution when handling heavy parts. Lifting device is required when parts weigh over 50 lb (23 kg) for a single person lift, over 100 lb (45 kg) for a two person lift, and over 150 lb (68 kg) for a three or more person lift. Keep clear of heavy parts supported only by lifting device. Failure to follow this warning may cause serious injury or death to personnel.

1. Using lifting device, support canopy or ROPS (4).
2. Remove four screws (7), washers (6), lockwashers (5), and front crossmember (3) from canopy or ROPS (4). Discard lockwashers.

NOTE

If removing right front mounts and special bracket, skip step 3.

3. Remove screw (1), two clamps (12), hydraulic lines (2), spacer (11), lockwasher (10), and nut (9) from special bracket weldment (8). Discard lockwasher.

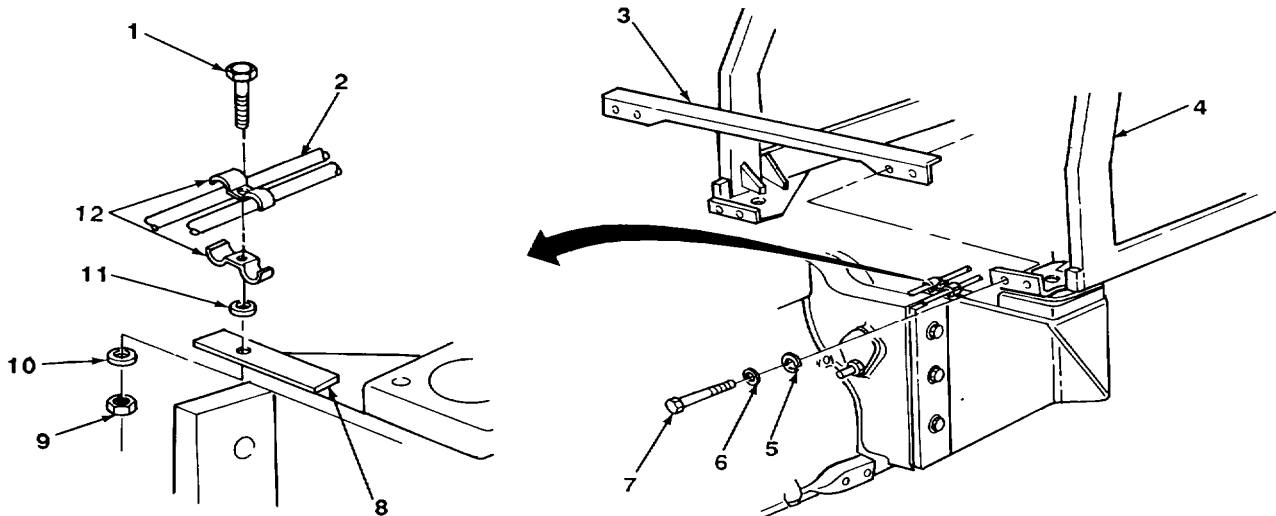

TA701508

13-1. ROLL-OVER PROTECTIVE STRUCTURE OR CANOPY FRONT MOUNTS AND BRACKETS MAINTENANCE (Con't).

4. Remove nut (22), lockwasher (21), lower front mount (19), washer (20), and screw (13) from canopy or ROPS (4) and special bracket (16). Discard lockwasher.

NOTE

Only loader backhoes with serial numbers 319995-342573 have lockwashers with screws attaching special bracket to reverser housing.

5. Remove screw (23), lockwasher (24), and washer (25), if present, from special bracket (16) and reverser housing (29). Discard lockwasher.
6. Remove two screws (26), lockwashers (27), and washers (28), if present, upper front mount (14), and special bracket (16) with assembled parts from reverser housing (29) and canopy or ROPS (4). Discard lockwashers.

b. DISASSEMBLY

1. Remove upper front mount (14) from retaining plate (15).
2. Remove two capscrews (18), lockwashers (17), and retaining plate (15) from special bracket (16). Discard lockwashers.

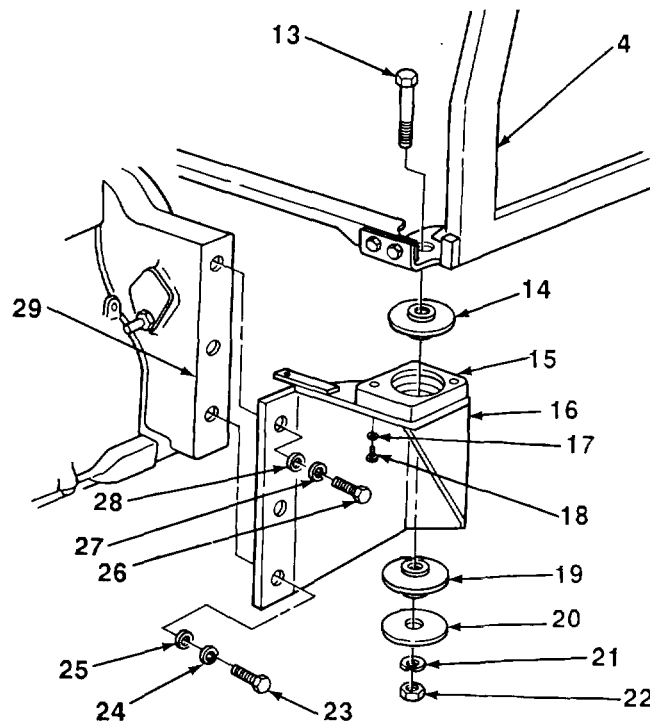

TA701509

13-1. ROLL-OVER PROTECTIVE STRUCTURE OR CANOPY FRONT MOUNTS AND BRACKETS MAINTENANCE (Con't).

c. CLEANING AND INSPECTION

1. Clean lower and upper front mounts with clean rags and water and detergent solution. Rinse with clean water. Dry thoroughly with clean, dry rags.

WARNING

Dry cleaning solvent, P-D-680, is toxic and flammable. Always wear protective goggles and gloves, and use only in a well-ventilated area. Avoid contact with skin, eyes, and clothes, and DO NOT breathe vapors. DO NOT use near open flame or excessive heat. The solvent's flash point is 100°F-1380F (380C-590C). If you become dizzy while using cleaning solvent, immediately get fresh air and medical help. If solvent contacts eyes, immediately wash your eyes and get medical aid.

2. Clean special bracket, retaining plate, and all other metal parts with dry cleaning solvent and rags. Dry thoroughly with clean, dry rags.
3. Inspect special bracket and all other metal parts for cracks, breaks, and abnormal bends.
4. Inspect retaining plate for damaged threads.

d. REPAIR

Restore damaged retaining plate (15) threads using screw threading set.

e. ASSEMBLY

1. Position retaining plate (15) on special bracket (16) and install two capscrews (18) and new lockwashers (17).
2. Install upper front mount (14) on retaining plate (15).

f. INSTALLATION

WARNING

Use extreme caution when handling heavy parts. Lifting device is required when parts weigh over 50 lb (23 kg) for a single person lift, over 100 lb (45 kg) for a two person lift, and over 150 lb (68 kg) for a three or more person lift. Keep clear of heavy parts supported only by lifting device. Failure to follow this warning may cause serious injury or death to personnel.

1. With the aid of an assistant, position special bracket (16) with assembled parts on reverser housing (29) and canopy or ROPS (4).

NOTE

Only loader backhoes with serial numbers 319995-342573 have lockwashers with screws attaching special bracket to reverser housing.

2. Install two screws (26), new lockwashers (27), and washers (28), if present, in special bracket (16) and reverser housing (29).

13-1. ROLL-OVER PROTECTIVE STRUCTURE OR CANOPY FRONT MOUNTS AND BRACKETS MAINTENANCE (Con't).

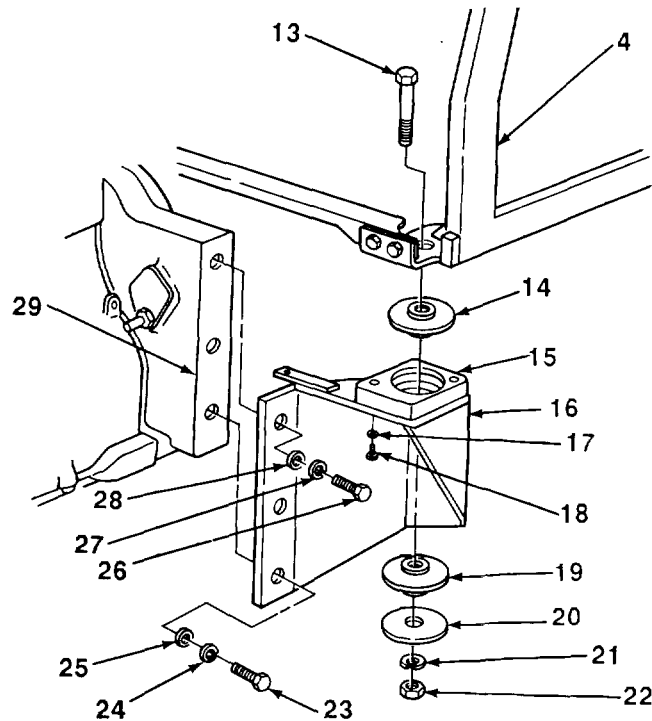

3. Install screw (23), new lockwasher (24), and washer (25), if present, in special bracket (16) and reverser housing (29).
4. Position lower front mount (19) under special bracket (16) and hold in place.
5. Install screw (13), washer (20), new lockwasher (21), and nut (22) in canopy or ROPS (4), upper front mount (14), special bracket (16), and lower front mount (19).

TA701510

13-1. ROLL-OVER PROTECTIVE STRUCTURE OR CANOPY FRONT MOUNTS AND BRACKETS MAINTENANCE (Con't).

NOTE

If installing right special bracket and front mounts, skip step 6.

6. Install screw (1), two clamps (12), spacer (11), new lockwasher (10), and nut (9) on two hydraulic lines (2) and special bracket weldment (8).
7. Position front crossmember (3) in place on canopy or ROPS (4) and secure with four screws (7), washers (6), and new lockwashers (5).
8. Remove lifting device from canopy of ROPS (4).

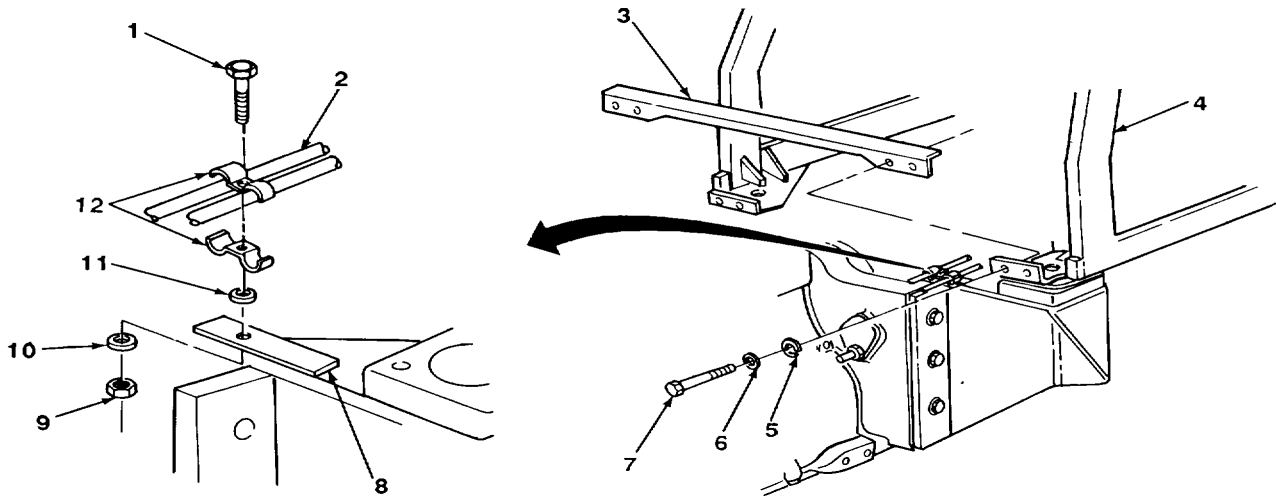

FOLLOW-ON TASKS:

NOTE

Perform the following only if left front mounts were removed.

- Install left platform (see TM 5-2420-222-20).

NOTE

Perform the following only if right front mounts were removed.

- Install accumulator (see TM 5-2420-222-20).
- Install right platform (see TM 5-2420-222-20).

NOTE

Perform the following if right and left front mounts were removed.

- Install left outer platform (see TM 5-2420-222-20).
- Install right inner platform (see TM 5-2420-222-20).

13-2. CANOPY PROTECTIVE ROOF MAINTENANCE (SERIAL NUMBERS 235786- 235999).

This Task Covers:

- | | |
|----------------------------|-----------------|
| a. Removal | d. Assembly |
| b. Disassembly | e. Installation |
| c. Cleaning and Inspection | |
-

Initial Setup:

Tools/Test Equipment:

- General mechanic's tool kit
- Field automotive shop set

Personnel Required: Two

Materials/Parts:

- Detergent (Item 13, Appendix B)
- Rags (Item 28, Appendix B)
- Dry cleaning solvent (Item 31, Appendix B)

General Safety Instructions:

- Dry cleaning solvent is flammable and must not be used near open flame. Use only in a well-ventilated area.
-

a. REMOVAL

WARNING

Use extreme caution when handling heavy parts. Lifting device is required when parts weigh over 50 lb (23 kg) for a single person lift, over 100 lb (45 kg) for a two person lift, and over 150 lb (68 kg) for a three or more person lift. Keep clear of heavy parts supported only by lifting device. Failure to follow this warning may cause serious injury or death to personnel.

13-2. CANOPY PROTECTIVE ROOF MAINTENANCE (SERIAL NUMBERS 235786-235999) (Con't).

1. Using lifting device, support canopy panel (1).
2. Remove eight nuts (7), washers (6), and bolts (5) from canopy (4) and canopy panel (1).
3. Remove 12 drive screws (2) from canopy panel (1) and canopy (4).
4. Using lifting device, remove canopy panel (1) from canopy (4) and set on wood blocks.

b. DISASSEMBLY

Remove two channels (3) from front and rear edge of canopy panel (1).

c. CLEANING AND INSPECTION**WARNING**

Dry cleaning solvent, P-D-680, is toxic and flammable. Always wear protective goggles and gloves, and use only in a well-ventilated area. Avoid contact with skin, eyes, and clothes, and DO NOT breathe vapors. DO NOT use near open flame or excessive heat. The solvent's flash point is 100°F-138°F (38°C-59°C). If you become dizzy while using cleaning solvent, immediately get fresh air and medical help. If solvent contacts eyes, immediately wash your eyes and get medical aid.

1. Clean canopy panel and all other metal parts with dry cleaning solvent and rags. Dry thoroughly with clean, dry rags.
2. Clean channels with rag dampened in water and detergent solution. Rinse with clean water and dry thoroughly.
3. Inspect canopy panel and all other metal parts for cracks, breaks, and abnormal bends.
4. Inspect channels for cracks, tears, or crumbling.

d. ASSEMBLY

Position two channels (3) in place on front and rear edge of canopy panel (1).

13-2. CANOPY PROTECTIVE ROOF MAINTENANCE (SERIAL NUMBERS 235786-235999) (Con't).**e. INSTALLATION****WARNING**

Use extreme caution when handling heavy parts. Lifting device is required when parts weigh over 50 lb (23 kg) for a single person lift, over 100 lb (45 kg) for a two person lift, and over 150 lb (68 kg) for a three or more person lift. Keep clear of heavy parts supported only by lifting device. Failure to follow this warning may cause serious injury or death to personnel.

1. Using lifting device, position canopy panel (1) in place on canopy (4).
2. Install 12 drive screws (2) in canopy panel (1) and canopy (4).
3. Install eight nuts (7), washers (6), and bolts (5) in canopy (4) and canopy panel (1).
4. Remove lifting device from canopy panel (1).

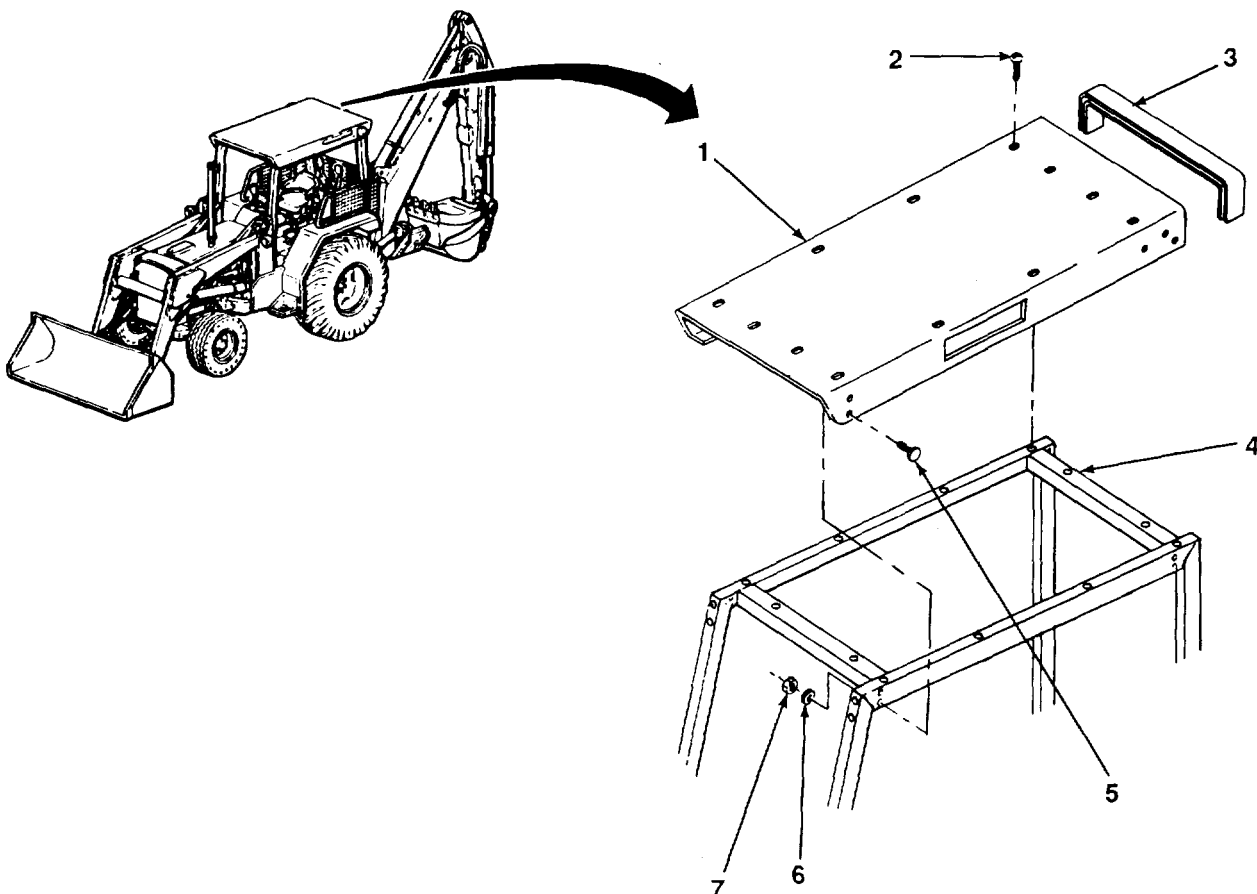

TA701512

13-3. CANOPY PROTECTIVE ROOF MAINTENANCE (SERIAL NUMBERS 319995- 342573).

This Task Covers:

- | | |
|----------------------------|-----------------|
| a. Removal | d. Assembly |
| b. Disassembly | e. Installation |
| c. Cleaning and Inspection | |

Initial Setup:

Tools/Test Equipment:

- General mechanic's tool kit
- Field automotive shop set

General Safety Instructions:

- Dry cleaning solvent is flammable and must not be used near open flame. Use only in a well-ventilated.

Materials/Parts:

- Detergent (Item 13, Appendix B)
- Rags (Item 28, Appendix B)
- Dry cleaning solvent (Item 31, Appendix B)

Personnel Required: Two

a. REMOVAL**WARNING**

Use extreme caution when handling heavy parts. Lifting device is required when parts weigh over 50 lb (23 kg) for a single person lift, over 100 lb (45 kg) for a two person lift, and over 150 lb (68 kg) for a three or more person lift. Keep clear of heavy parts supported only by lifting device. Failure to follow this warning may cause serious Injury or death to personnel.

1. Using lifting device, support canopy panel (1).
2. Remove four nuts (8), bolts (5), sleeve spacers (7), and 12 washers (6) from canopy (9) and canopy panel (1).
3. Remove four drive screws (3) and washers (2) from canopy panel (1) and canopy (9).
4. Using lifting device, remove canopy panel (1) from canopy (9) and set on wood blocks.

b. DISASSEMBLY

Remove two channels (4) from front and rear edge of canopy panel (1).

c. CLEANING AND INSPECTION**WARNING**

Dry cleaning solvent, P-D-680, is toxic and flammable. Always wear protective goggles and gloves, and use only in a well-ventilated area. Avoid contact with skin, eyes, and clothes, and DO NOT breathe vapors. DO NOT use near open flame or excessive heat. The solvent's flash point is 100°F-138°F (38°C-59°C). If you become dizzy while using cleaning solvent, immediately get fresh air and medical help. If solvent contacts eyes, immediately wash your eyes and get medical aid.

1. Clean canopy panel and all other metal parts with dry cleaning solvent and rags. Dry thoroughly with clean, dry rags.

13-3. CANOPY PROTECTIVE ROOF MAINTENANCE (SERIAL NUMBERS 319995- 342573) (Con't).

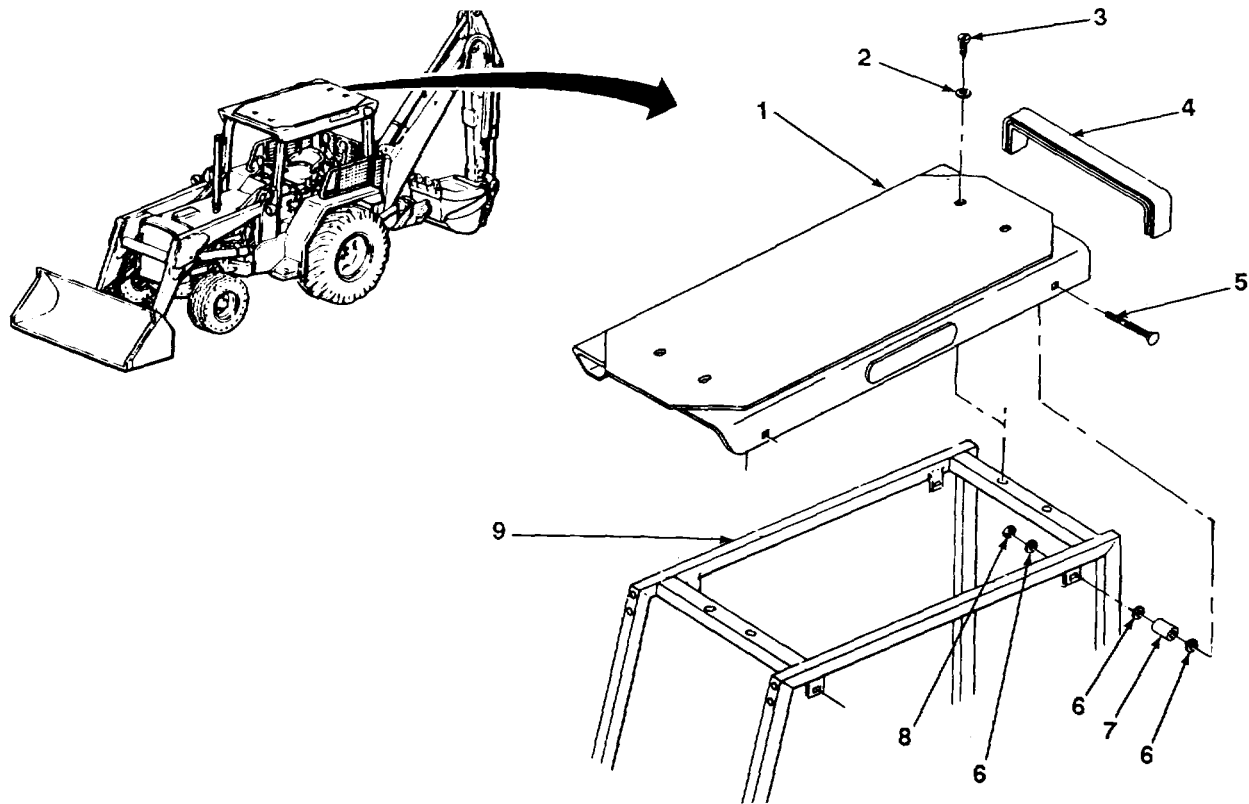

2. Clean channels with rag dampened in water and detergent solution. Rinse with clean water and dry thoroughly.
3. Inspect canopy panel and all other metal parts for cracks, breaks, and abnormal bends.
4. Inspect channels for cracks, tears, or crumbling.

d. ASSEMBLY

Position two channels (4) in place on front and rear edge of canopy panel (1).

e. INSTALLATION
WARNING

Use extreme caution when handling heavy parts. Lifting device is required when parts weigh over 50 lb (23 kg) for a single person lift, over 100 lb (45 kg) for a two person lift, and over 150 lb (68 kg) for a three or more person lift. Keep clear of heavy parts supported only by lifting device. Failure to follow this warning may cause serious injury or death to personnel.

1. Using lifting device, position canopy panel (1) in place on canopy (9).

13-3. CANOPY PROTECTIVE ROOF MAINTENANCE (SERIAL NUMBERS 319995- 342573) (Con't).

2. Install four drive screws (3) and washers (2) in canopy panel (1) and canopy (9).
3. Install four bolts (5), sleeve spacers (7), nuts (8), and 12 washers (6) in canopy (9) and canopy panel (1).
4. Remove lifting device from canopy panel (1).

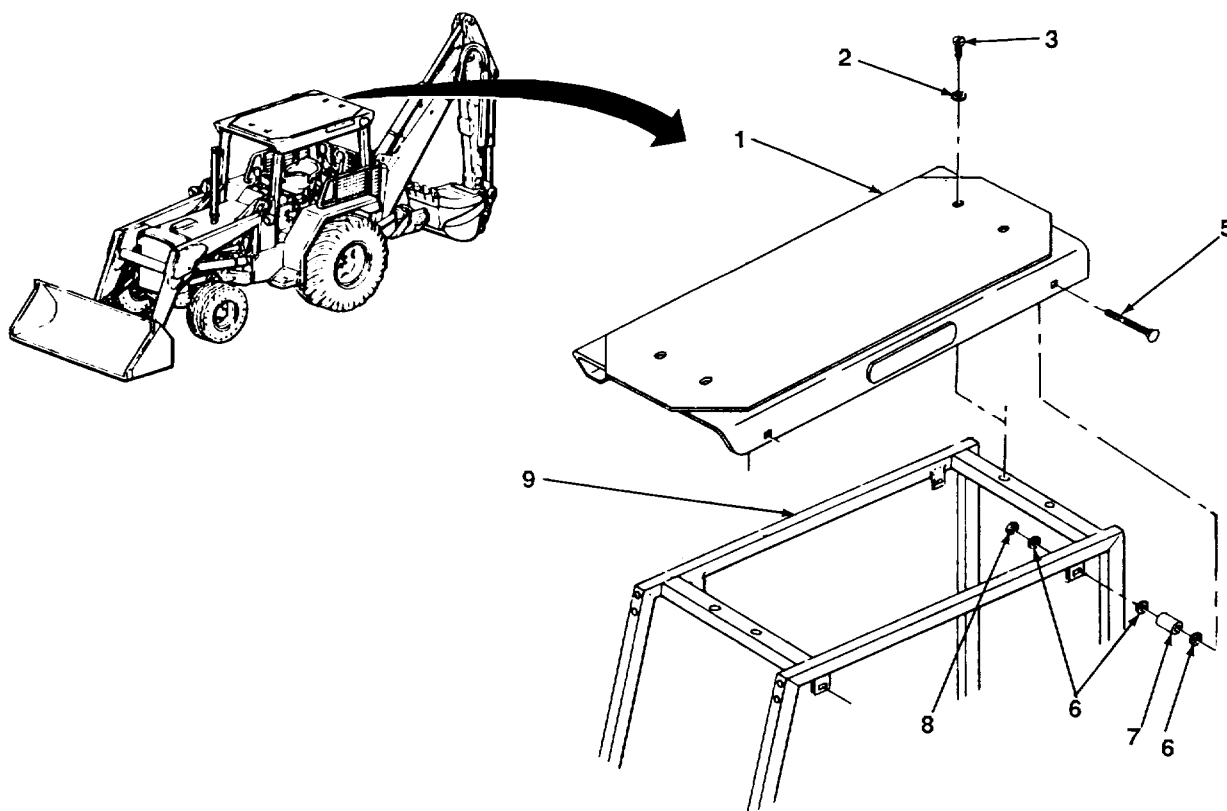

TA701514

13-4. ROLL-OVER PROTECTIVE STRUCTURE OR CANOPY REAR MOUNTS MAINTENANCE.

This Task Covers:

- | | | | |
|----|-------------------------|----|--------------|
| a. | Removal | d. | Repair |
| b. | Disassembly | e. | Assembly |
| c. | Cleaning and Inspection | f. | Installation |
-

Initial Setup:

Equipment Conditions:

- Rear wheels removed (see TM 5-2420-222-20).
- Fenders and supports removed (see paragraph 13-6).
- Warning lights removed (see TM 5-2420-222-20).
- Center platform removed (see TM 5-2420-222-20).
- Center platform support removed (see TM 5-2420-222-20).
- Loader backhoe control guards removed (see TM 5-2420-222-20)

Materials/Parts:

- Metal bonding adhesive (Item 1, Appendix B)
- Detergent (Item 13, Appendix B)
- Rags (Item 28, Appendix B)
- Dry cleaning solvent (Item 31, Appendix B)
- Lacing and tying tape (Item 37, Appendix B)
- Twenty lockwashers

Personnel Required: Two

General Safety Instructions:

- Dry cleaning solvent is flammable and must not be used near open flame. Use only in a well-ventilated area.
-

Tools/Test Equipment:

- General mechanic's tool kit
 - Field automotive shop set
-

NOTE

Loader backhoes with serial numbers 235786-235999 have a canopy. Loader backhoes with serial numbers 319995-342573 have a roll-over protective structure (ROPS).

13-4. ROLL-OVER PROTECTIVE STRUCTURE OR CANOPY REAR MOUNTS MAINTENANCE (Con't).

a. REMOVAL

WARNING

Use extreme caution when handling heavy parts. Lifting device is required when parts weigh over 50 lb (23 kg) for a single person lift, over 100 lb (45 kg) for a two person lift, and over 150 lb (68 kg) for a three or more person lift. Keep clear of heavy parts supported only by lifting device. Failure to follow this warning may cause serious injury or death to personnel.

1. Using floor jack, raise backhoe main frame (1) until tension is relieved on two pins (3).
2. Remove capscrew (4), nut (5), and pin (3) from left and right towbar (2) and backhoe main frame (1).
3. Raise and secure left and right towbar (2) to side frames (6).

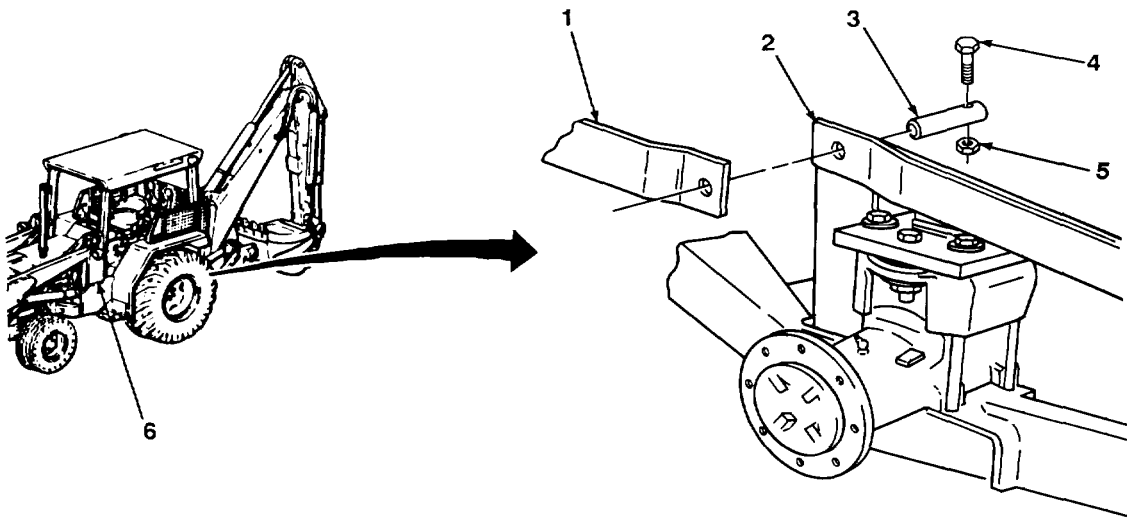

4. Using lifting device, support canopy or ROPS (7).
5. Remove four capscrews (18), washers (17), lockwashers (16), and front crossmember (15) from canopy or ROPS (7). Discard lockwashers.
6. Remove two nuts (14), lockwashers (13), washers (12), lower front mounts (11), and screws (8) from canopy or ROPS (7) and special brackets (10). Discard lockwashers.

TA701515

13-4. ROLL-OVER PROTECTIVE STRUCTURE OR CANOPY REAR MOUNTS MAINTENANCE (Con't).

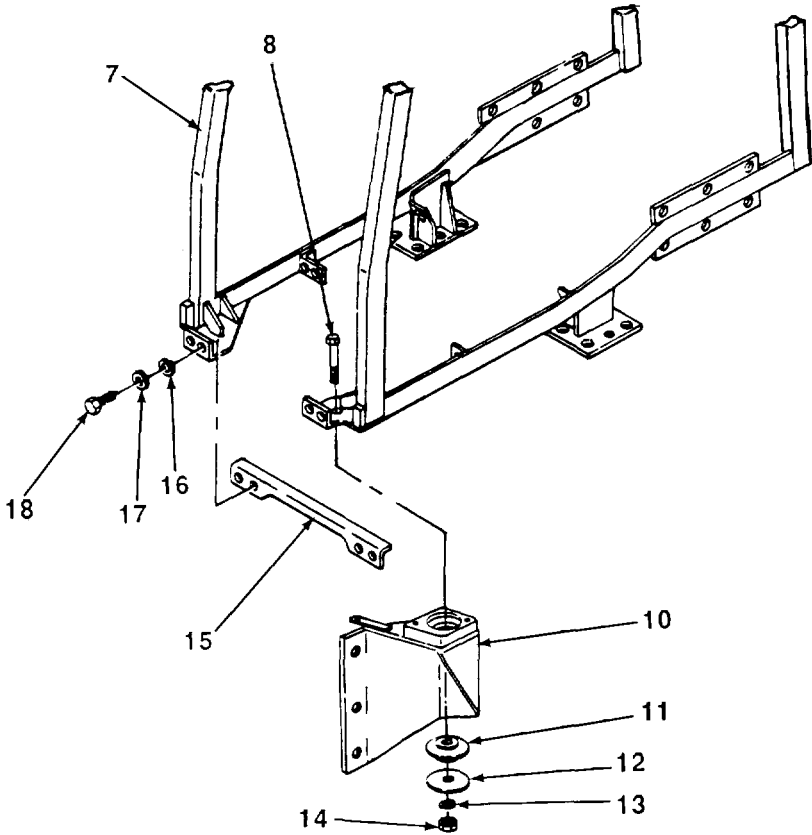

TA701516

13-4. ROLL-OVER PROTECTIVE STRUCTURE OR CANOPY REAR MOUNTS MAINTENANCE (Con't).

7. Remove two capscrews (19), lockwashers (20), nuts (38), and rear crossmember (21) from canopy or ROPS (7). Discard lockwashers.
8. Remove eight capscrews (22), washers (37), sleeve spacers (36), 16 spacers (35), eight spacers (34), lockwashers (33), and nuts (32) from canopy or ROPS (7), two canopy rear supports (9), and rear axle housings (30). Discard lockwashers.
9. Remove four capscrews (23), eight washers (24), four washers (25), upper rear mounts (26), lower rear mounts (27), washers (28), lockwashers (29), and nuts (31) from canopy or ROPS (7) and canopy rear supports (9). Discard lockwashers.
10. With the aid of an assistant and lifting device, remove canopy or ROPS (7).
11. Remove two canopy rear supports (9).

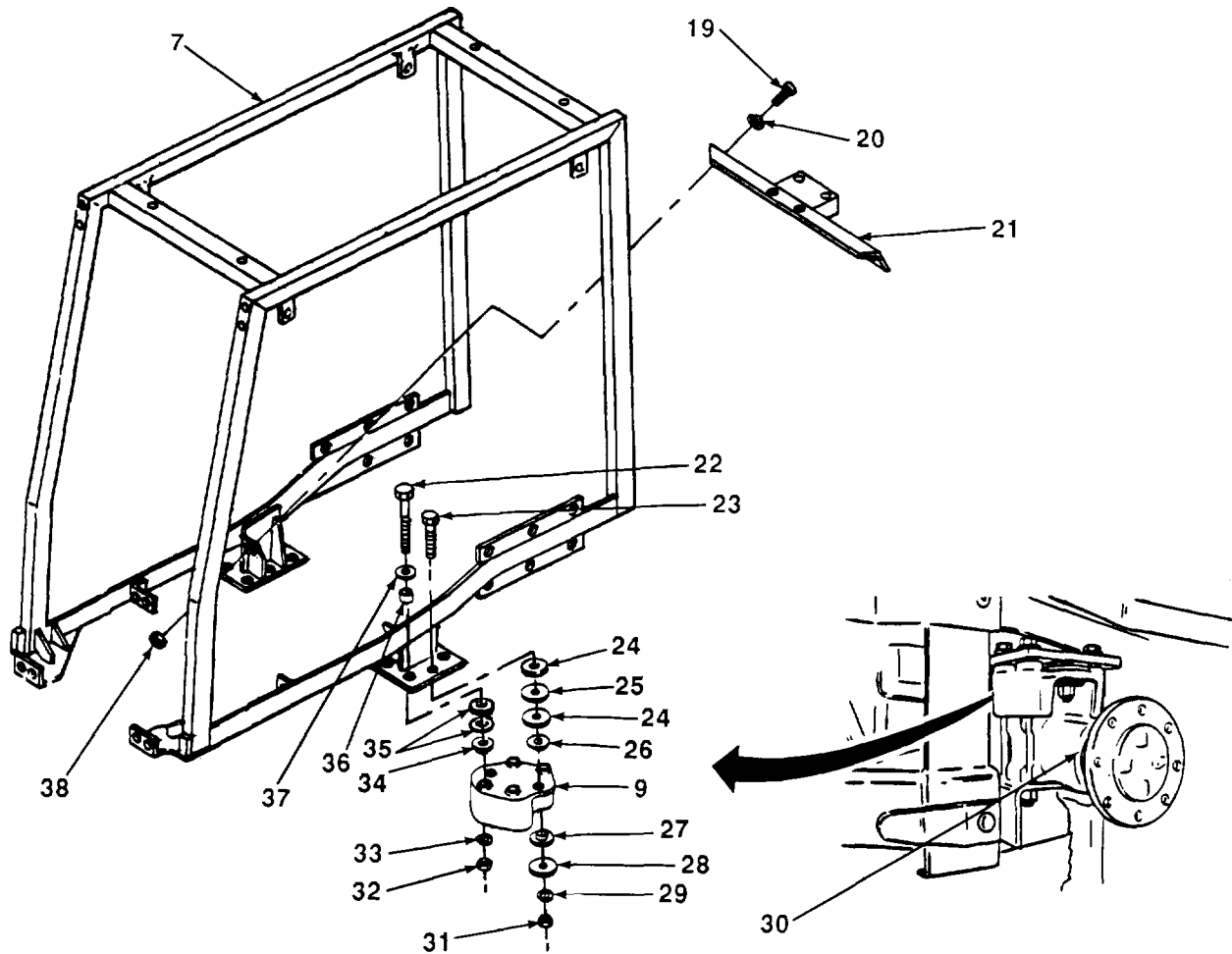

TA701517

13-4. ROLL-OVER PROTECTIVE STRUCTURE OR CANOPY REAR MOUNTS MAINTENANCE (Con't).**b. DISASSEMBLY**

1. Remove canopy protective roof (see paragraph 13-2 or 13-3).
2. Remove four grommets (39) from canopy or ROPS (7).

NOTE

**Both warning light leads are removed the same way. One side is shown.
Repeat step 3 for other side.**

3. Attach 6 ft (1.83 m) length of lacing and tying tape to warning light lead (40).
4. Pull warning light lead (40) through canopy or ROPS (7) until both ends of lacing and tying tape are visible, then remove warning light lead from tape.

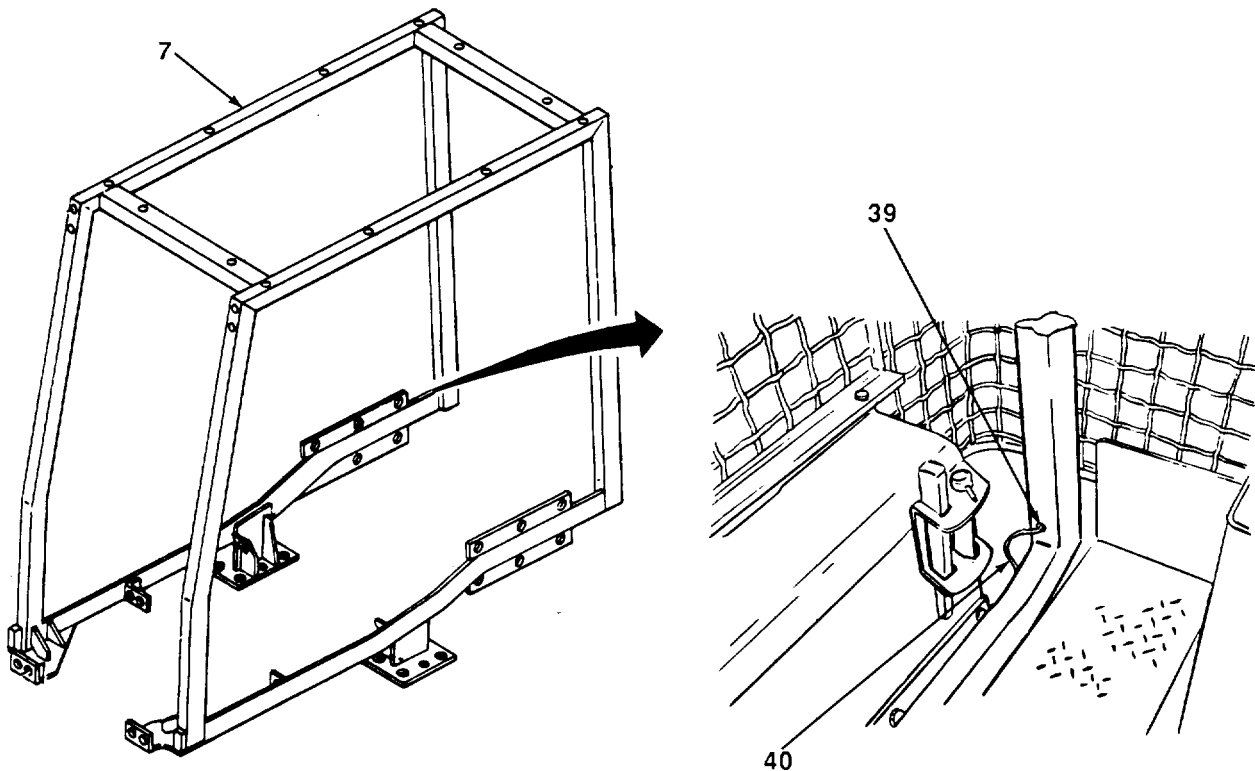

TA701518

13-4. ROLL-OVER PROTECTIVE STRUCTURE OR CANOPY REAR MOUNTS MAINTENANCE (Con't).**WARNING**

Dry cleaning solvent, P-D-680, is toxic and flammable. Always wear protective goggles and gloves, and use only in a well-ventilated area. Avoid contact with skin, eyes, and clothes, and **DO NOT** breathe vapors. **DO NOT** use near open flame or excessive heat. The solvent's flash point is 100°F-138°F (38°C-59°C). If you become dizzy while using cleaning solvent, immediately get fresh air and medical help. If solvent contacts eyes, immediately wash your eyes and get medical aid.

CAUTION

Do not remove seal unless damaged. Removal may damage seal.

NOTE

Steps 5 and 6 apply only to loader backhoes with serial numbers 319995-342573.

5. Lift up corner of seal (41) and dissolve adhesive with rags and dry cleaning solvent. Continue to wet seal and mounting surface with dry cleaning solvent until seal is completely removed from canopy or ROPS (7).
6. Remove all adhesive from mounting surface with dry cleaning solvent and rags, then rinse with clean water. Dry thoroughly with clean, dry rags.

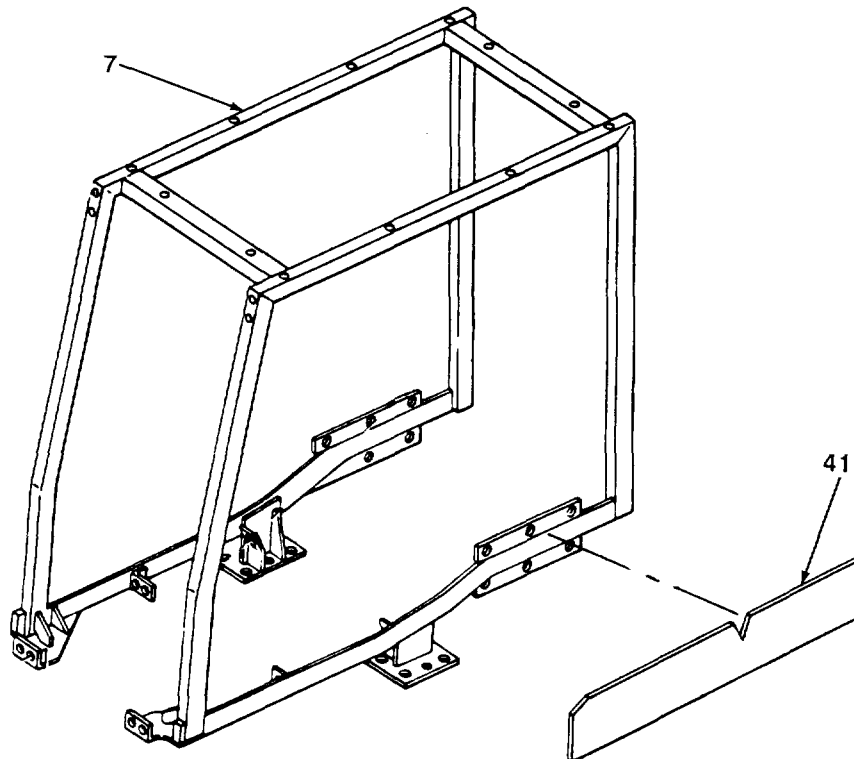

TA701519

13-4. ROLL-OVER PROTECTIVE STRUCTURE OR CANOPY REAR MOUNTS MAINTENANCE (Con't).

c. CLEANING AND INSPECTION

1. Clean seals and grommets with water and detergent solution and rags. Rinse with clean water and dry thoroughly.

WARNING

Dry cleaning solvent, P-D-680, is toxic and flammable. Always wear protective goggles and gloves, and use only in a well-ventilated area. Avoid contact with skin, eyes, and clothes, and DO NOT breathe vapors. DO NOT use near open flame or excessive heat. The solvent's flash point is 100°F-138°F (38°C-59°C). If you become dizzy while using cleaning solvent, immediately get fresh air and medical help. If solvent contacts eyes, immediately wash your eyes and get medical aid.

2. Clean canopy or ROPS and all other metal parts with dry cleaning solvent and rags. Dry thoroughly with clean, dry rags.
3. Inspect canopy or ROPS and all other metal parts for cracks, breaks, and abnormal bends.
4. Inspect canopy or ROPS and rear crossmember for damaged threads.

d. REPAIR

Restore damaged canopy, ROPS, or rear crossmember threads using screw threading set.

e. ASSEMBLY**NOTE**

Steps 1 and 2 apply only to loader backhoes with serial numbers 319995-342573, if seal was removed.

1. Apply metal bonding adhesive in J8 in. (3.18 mm) wide beads in 2 in. (50.80 mm) or smaller squares on seal (41). Ensure that outside bead has no gaps and is within 1/4 in. (6.35 mm) from edge of seal.
2. Press seal (41) in place on canopy or ROPS (7), then remove seal and allow adhesive to set for two minutes. Align seal with canopy or ROPS and press firmly in place.

13-4. ROLL-OVER PROTECTIVE STRUCTURE OR CANOPY REAR MOUNTS MAINTENANCE (Con't).**NOTE**

Both warning light leads are installed the same way. One side is shown. Repeat step 3 for other side.

3. Attach routed lacing and tying tape to warning light lead (40). Pull lacing and tying tape with attached warning light lead through canopy or ROPS (7) until lead is visible at both ends. Remove lacing and tying tape.
4. Install four grommets (39) in canopy or ROPS (7).
5. Install canopy protective roof (see paragraph 13-2 or 13-3).

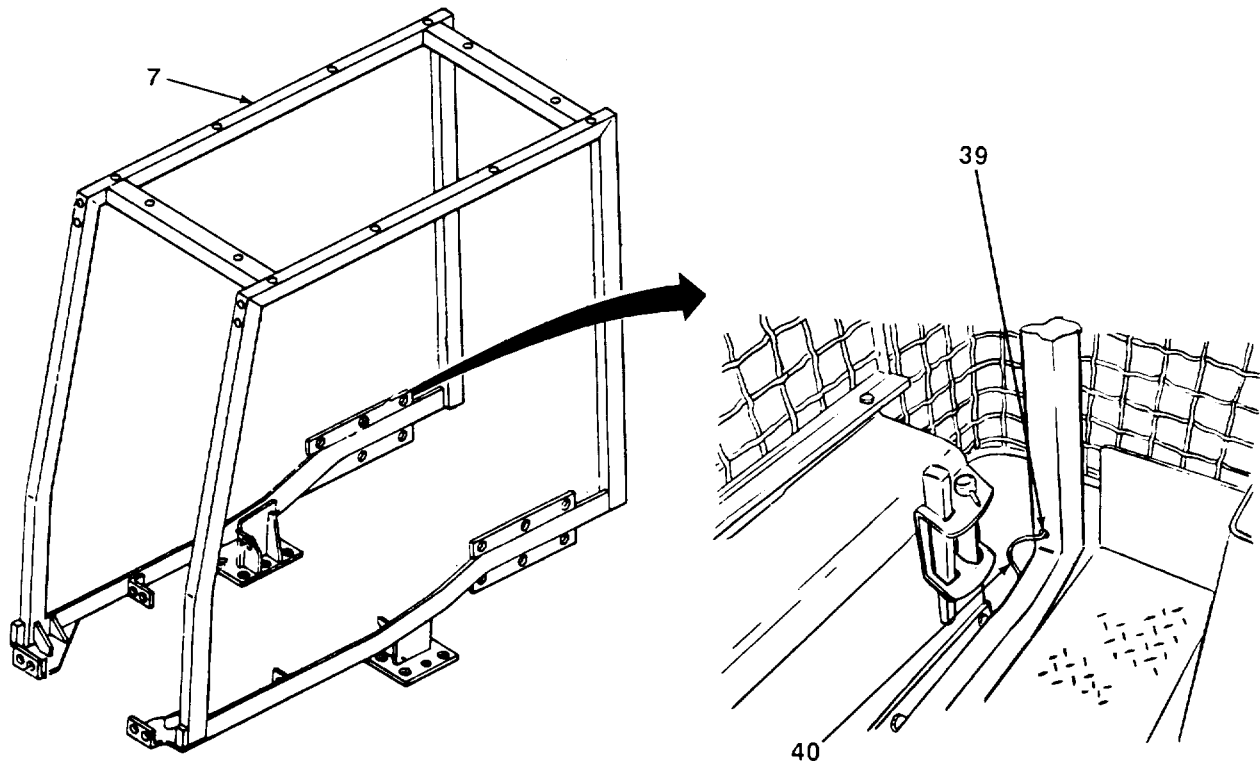

TA701520

13-4. ROLL-OVER PROTECTIVE STRUCTURE OR CANOPY REAR MOUNTS MAINTENANCE (Con't).

f. INSTALLATION

WARNING

Use extreme caution when handling heavy parts. Lifting device is required when parts weigh over 50 lb (23 kg) for a single person lift, over 100 lb (45 kg) for a two person lift, and over 150 lb (68 kg) for a three or more person lift. Keep clear of heavy parts supported only by lifting device. Failure to follow this warning may cause serious injury or death to personnel.

- 1. Position two canopy rear supports (9), four upper rear mounts (26), eight washers (24), four washers (25), 16 spacers (35), and eight spacers (34) in place on rear axle housings (30).

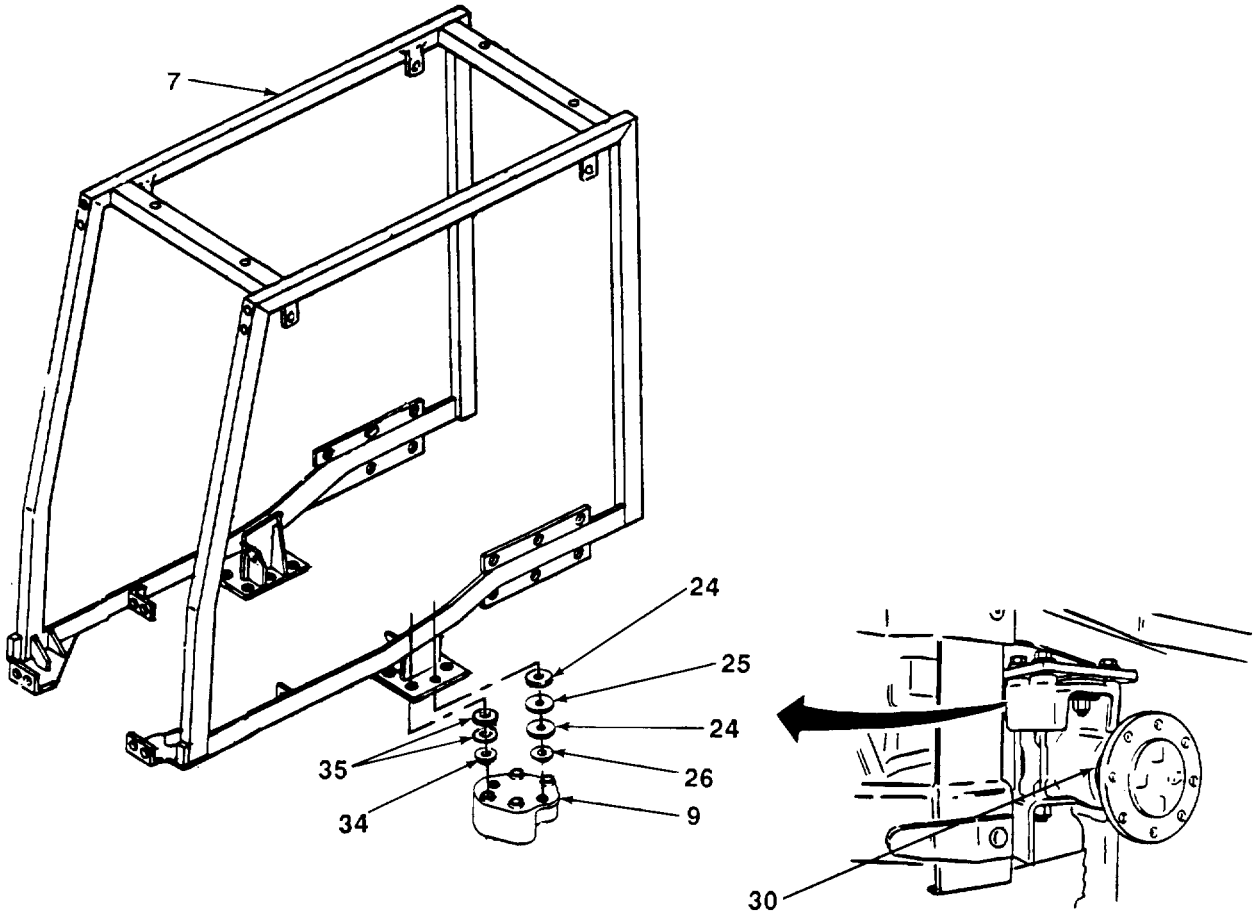

TA701521

13-4. ROLL-OVER PROTECTIVE STRUCTURE OR CANOPY REAR MOUNTS MAINTENANCE (Con't).

2. With the aid of an assistant and lifting device, position canopy or ROPS (7) in place on two canopy rear supports (9) and two special brackets (10) with mounting holes aligned.

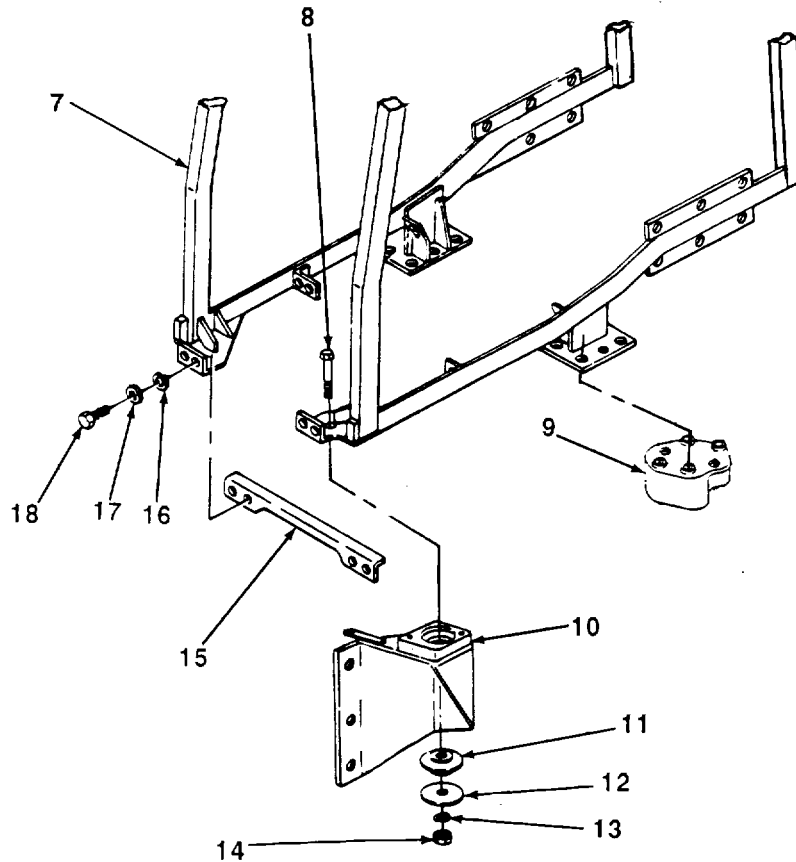

3. Install four capscrews (23), eight washers (24), four washers (25), lower rear mounts (27), washers (28), new lockwashers (29), and nuts (31) in canopy or ROPS (7) and two canopy rear supports (9).
4. With the aid of an assistant, install eight capscrews (22), sleeve spacers (36), washers (37), spacers (35 and 34), new lockwashers (33), and nuts (32) in canopy or ROPS (7), two canopy rear supports (9), and rear axle housings (30).
5. Position rear crossmember (21) in place on canopy or ROPS (7) and secure with four capscrews (19), new lockwashers (20), and nuts (38).

13-4. ROLL-OVER PROTECTIVE STRUCTURE OR CANOPY REAR MOUNTS MAINTENANCE (Con't).

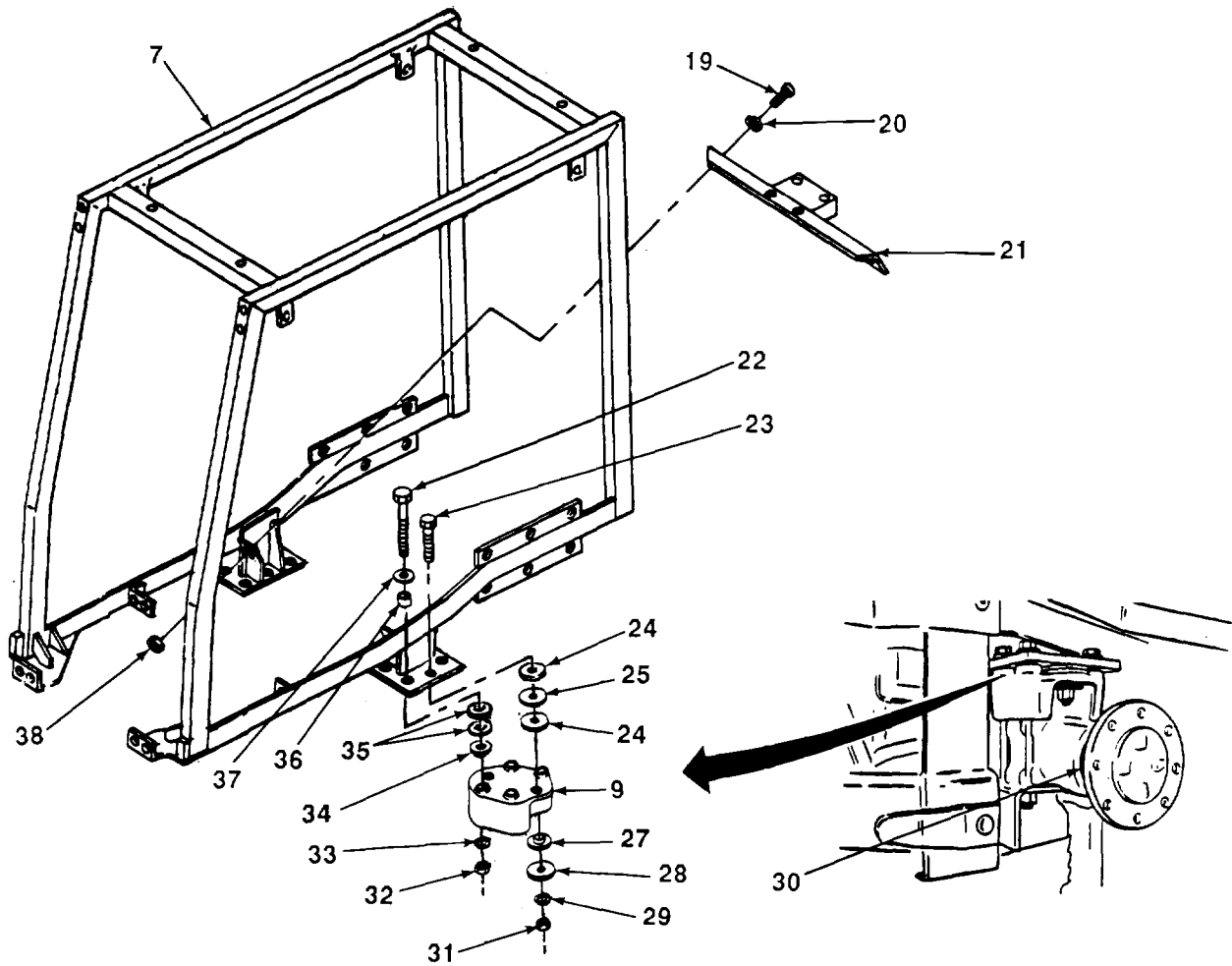

6. Install two screws (8), lower front mounts (11), washers (12), new lockwashers (13), and nuts (14) in canopy or ROPS (7) and two special brackets (10).
7. Position front crossmember (15) in place on canopy or ROPS (7) and secure with four cap screws (18), washers (17), and new lockwashers (16).
8. Remove lifting device from canopy or ROPS (7).

TA701523

13-4. ROLL-OVER PROTECTIVE STRUCTURE OR CANOPY REAR MOUNTS MAINTENANCE (Con't).

9. Release and lower left and right towbar (2).
10. Secure left and right towbar (2) to backhoe main frame (1) with pin (3), nut (5), and capscrew (4).
11. Lower floor jack from under backhoe main frame (1) and remove.

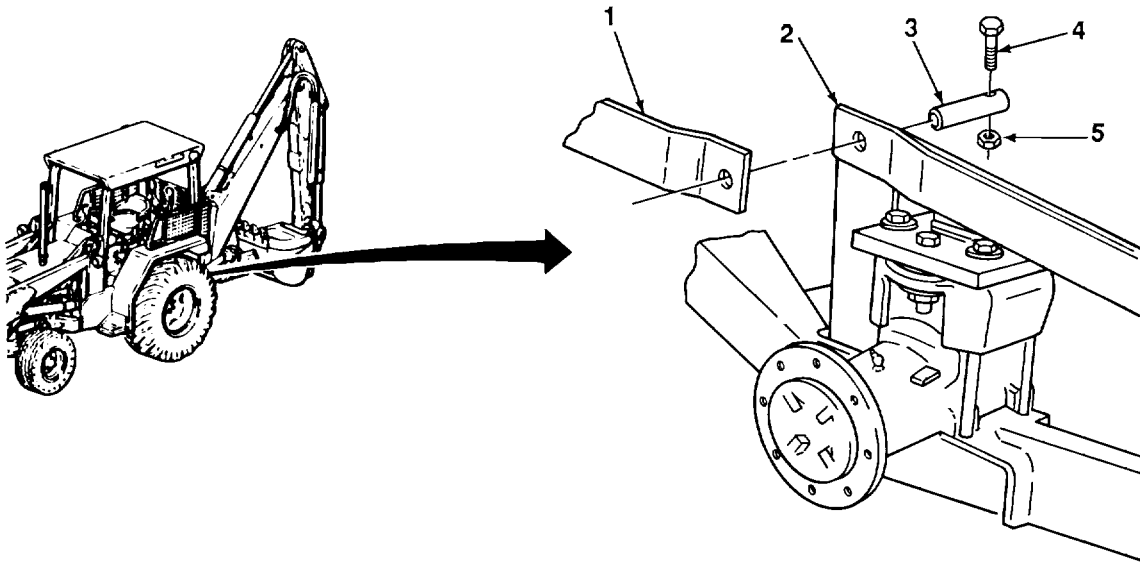
**FOLLOW-ON TASKS:**

- Install loader backhoe control guards (see TM 5-2420-222-20).
- Install center platform support (see TM 5-2420-222-20).
- Install center platform (see TM 5-2420-222-20).
- Install warning lights (see TM 5-2420-222-20).
- Install fenders and supports (see paragraph 13-6).
- Install rear wheels (see TM 5-2420-222-20).

TA701524

13-5. COWL SUPPORT MAINTENANCE.

This Task Covers:

- | | | |
|----------------------------|----|-----------------|
| a. Removal | d. | Assembly |
| b. Disassembly | | e. Installation |
| c. Cleaning and Inspection | | |
-

*Initial Setup:***Equipment Conditions:**

- Accelerator pedal, foot accelerator rod, and speed control arms removed (see TM 5-2420-222-20).
- Reverser control lever removed (see TM 5-2420-222-20).
- Circuit breakers removed (see TM 5-2420-222-20).
- Electric horn and bracket removed (see TM 5-2420-222-20).
- Parking brake relay removed (see TM 5-2420-222-20).

Tools/Test Equipment:

- General mechanic's tool kit
- Field automotive shop set

Materials/Parts:

- Metal bonding adhesive (Item 1, Appendix B)
- Detergent (Item 13, Appendix B)
- Rags (Item 28, Appendix B)
- Dry cleaning solvent (Item 31, Appendix B)
- One cotter pin
- Twelve lockwashers

References:

- TM 5-2420-222-20

General Safety Instructions:

- Dry cleaning solvent is flammable and must not be used near open flame. Use only in a well-ventilated area.
-

13-5. COWL SUPPORT MAINTENANCE (Con't).

a. REMOVAL

NOTE

Some loader backhoes may not have hanger and retaining strap. If parts are not present, skip steps 1 and 2.

1. Remove two capscrews (6), washers (5), lockwashers (2), nuts (1), and retaining strap (4) from hanger (3). Discard lockwashers.

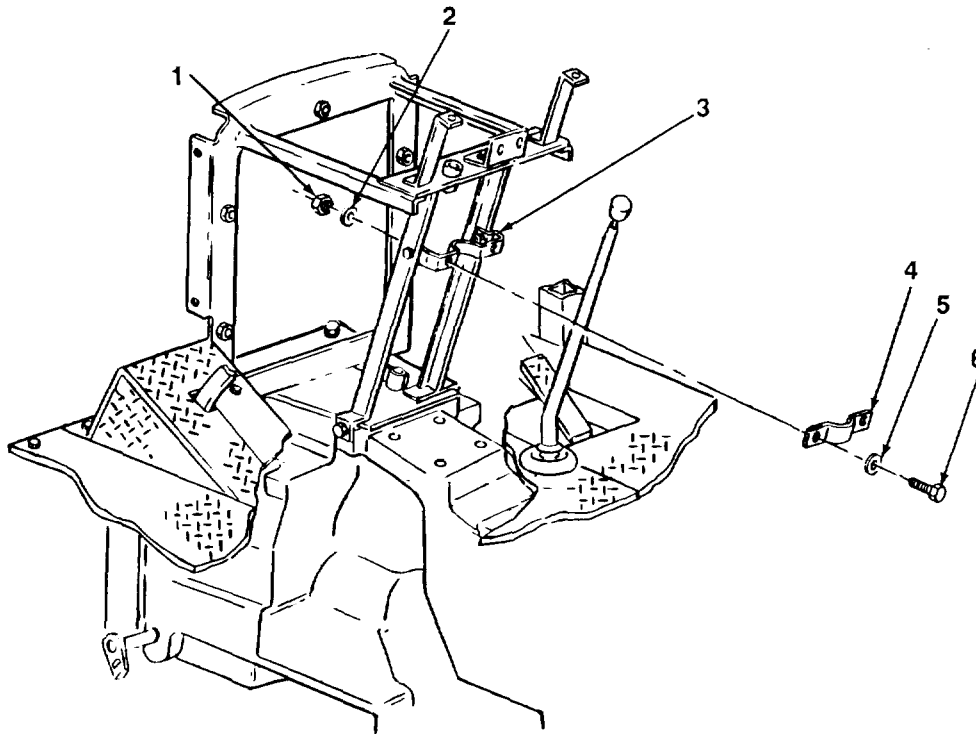

2. Remove two capscrews (19), washers (18), lockwashers (8), nuts (9), and hanger (3) from steering column (16) and cowl support (7). Discard lockwashers.
3. Remove two nuts (13), lockwashers (14), washers (15), and U-bolt (17) from steering column (16) and angle bracket (11). Discard lockwashers.
4. Remove two screws (12), lockwashers (10), nuts (20), and angle bracket (11) from cowl support (7). Discard lockwashers.
5. Remove cotter pin (22), washer (23), and speed control shaft rod (24) from shaft (21). Discard cotter pin.
6. Remove two screws (28), lockwashers (27), and sleeve spacers (26) from cowl support (7) and reverser housing (25). Discard lockwashers.

TA701525

13-5. COWL SUPPORT MAINTENANCE (Con't).

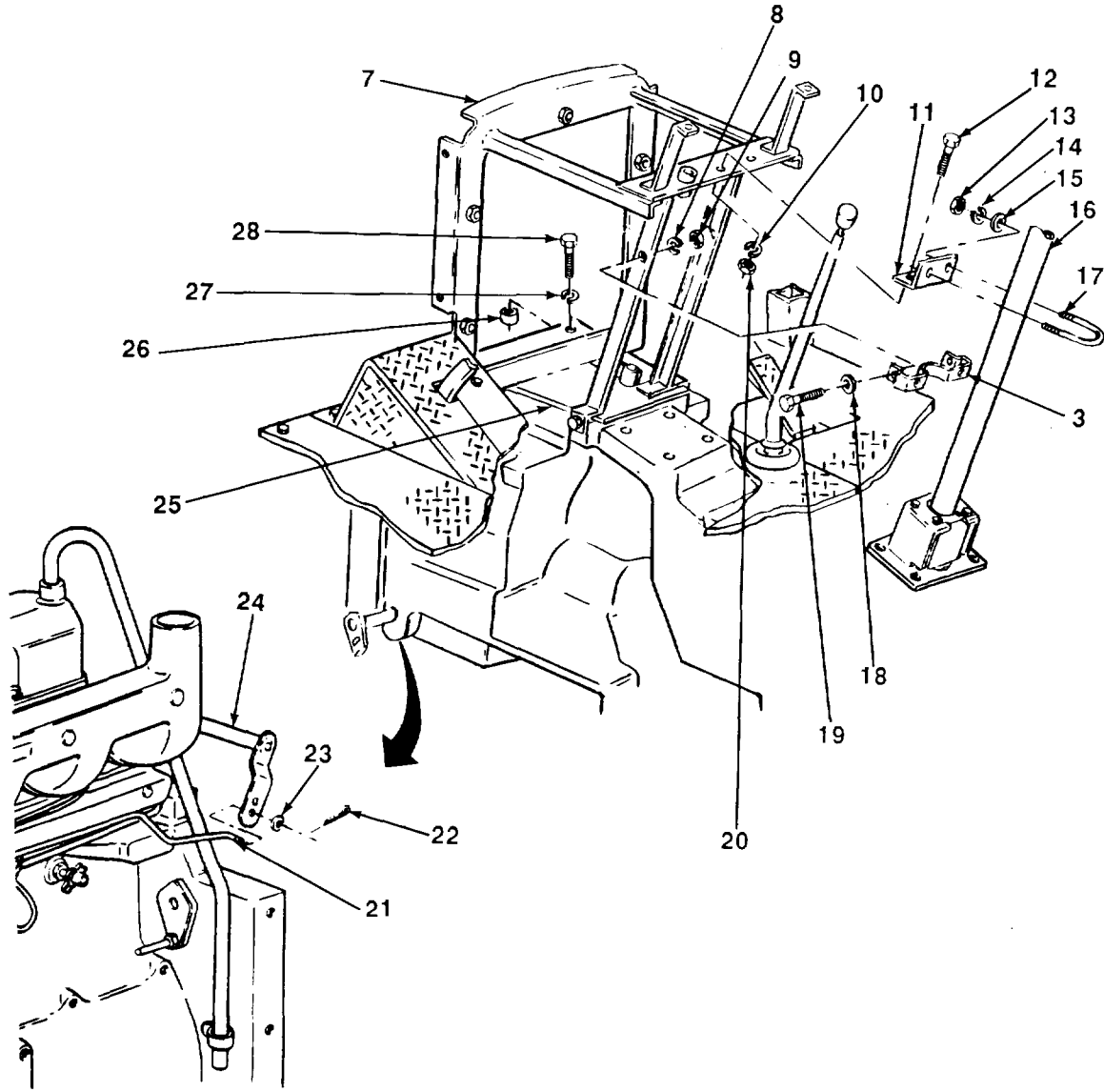

TA701526

13-5. COWL SUPPORT MAINTENANCE (Con't).

7. Remove two capscrews (30), lockwashers (31), and angle bracket (33) from cowl support (7) and reverser housing (25). Discard lockwashers.
8. Remove cowl support (7) from steering column (16) and reverser housing (25).

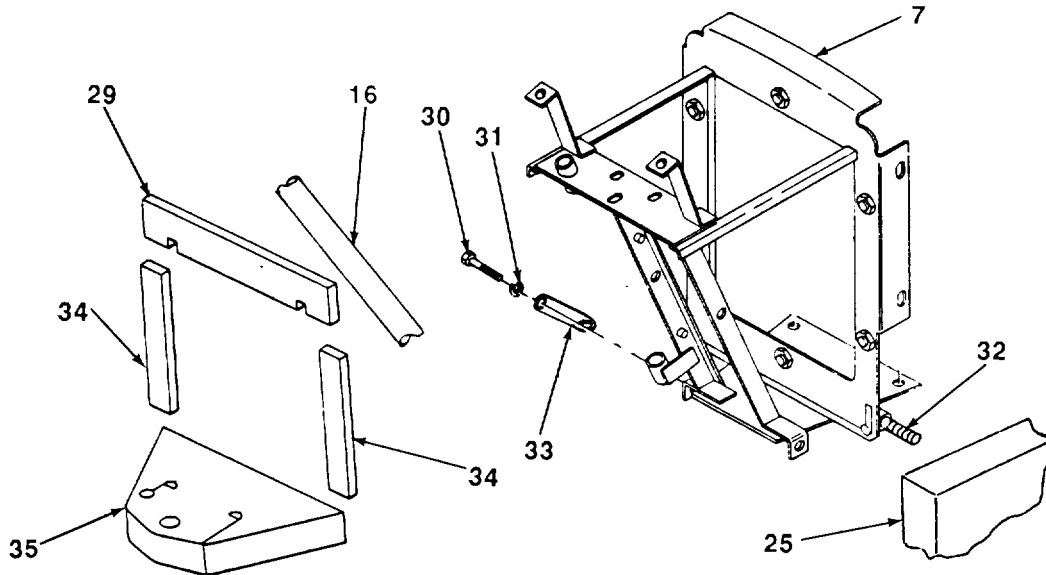
**b. DISASSEMBLY****WARNING**

Dry cleaning solvent, P-D-680, is toxic and flammable. Always wear protective goggles and gloves, and use only in a well-ventilated area. Avoid contact with skin, eyes, and clothes, and **DO NOT** breathe vapors. **DO NOT** use near open flame or excessive heat. The solvent's flash point is 100°F-138°F (38°C-59°C). If you become dizzy while using cleaning solvent, immediately get fresh air and medical help. If solvent contacts eyes, immediately wash your eyes and get medical aid.

CAUTION

Do not remove cowl barriers unless damaged. Removal may damage barriers.

NOTE

Removal is the same for all cowl barriers. Repeat steps 1 and 2 for others as required.

1. Lift up corner of cowl barrier (29, 34, or 35) and dissolve adhesive with dry cleaning solvent and rags. Continue to wet with dry cleaning solvent until cowl barrier is completely off cowl support (7).
2. Clean adhesive off cowl support (7) with dry cleaning solvent and clean rags. Rinse with water and dry thoroughly.

TA701527

13-5. COWL SUPPORT MAINTENANCE (Con't).

3. Remove warning light flasher and bracket (see TM 5-2420-222-20).
4. Remove speed control shaft (32) from cowl support (7).

c. CLEANING AND INSPECTION

1. Clean cowl support and assembled cowl barriers with clean rags and a solution of water and detergent. Rinse with clean water and dry thoroughly with clean, dry rags.

WARNING

Dry cleaning solvent, P-D-680, is toxic and flammable. Always wear protective goggles and gloves, and use only in a well-ventilated area. Avoid contact with skin, eyes, and clothes, and DO NOT breathe vapors. DO NOT use near open flame or excessive heat. The solvent's flash point is 100°F-138°F (38°C-59°C). If you become dizzy while using cleaning solvent, immediately get fresh air and medical help. If solvent contacts eyes, immediately wash your eyes and get medical aid.

2. Clean all other metal parts with dry cleaning solvent and rags. Dry thoroughly with clean, dry rags.
3. Inspect all metal parts for cracks, breaks, and abnormal bends.
4. Inspect cowl barriers for cracks, rips, tears, and crumbling.

d. ASSEMBLY**NOTE**

Perform steps 1 and 2 only if cowl barriers were removed.

1. Apply metal bonding adhesive in 8 in. (3.18 mm) wide beads in 2 in. (50.80 cm) or smaller squares on cowl barrier (29, 34, or 35). Ensure that outside bead has no gaps and is within 1/4 in. (6.35 mm) from edge of cowl
2. Press cowl barrier (29, 34, or 35) in place on cowl support (7), then remove and allow adhesive to set for two minutes. Aline cowl barrier with cowl support and press firmly in place.
3. Install speed control shaft (32) in place on cowl support (7).
4. Install warning light flasher and bracket (see TM 5-2420-222-20).

e. INSTALLATION

1. Install cowl support (7) in place on steering column (16) and reverser housing (25).
2. Install two capscrews (30), new lockwashers (31), and angle bracket (33) in cowl support (7) and reverser housing (25).

13-5. COWL SUPPORT MAINTENANCE (Con't).

- 3. Install two screws (28), new lockwashers (27), and sleeve spacers (26) in cowl support (7) and reverser housing
- 4. Position speed control shaft rod (24) in shaft (21) and secure with washer (23) and new cotter pin (22). (25).
- 5. Position angle bracket (11) on cowl support (7) and steering column (16) and secure with two screws (12), new lockwashers (10), and nuts (20).
- 6. Install U-bolt (17), two washers (15), new lockwashers (14), and nuts (13) on steering column (16) and angle bracket.

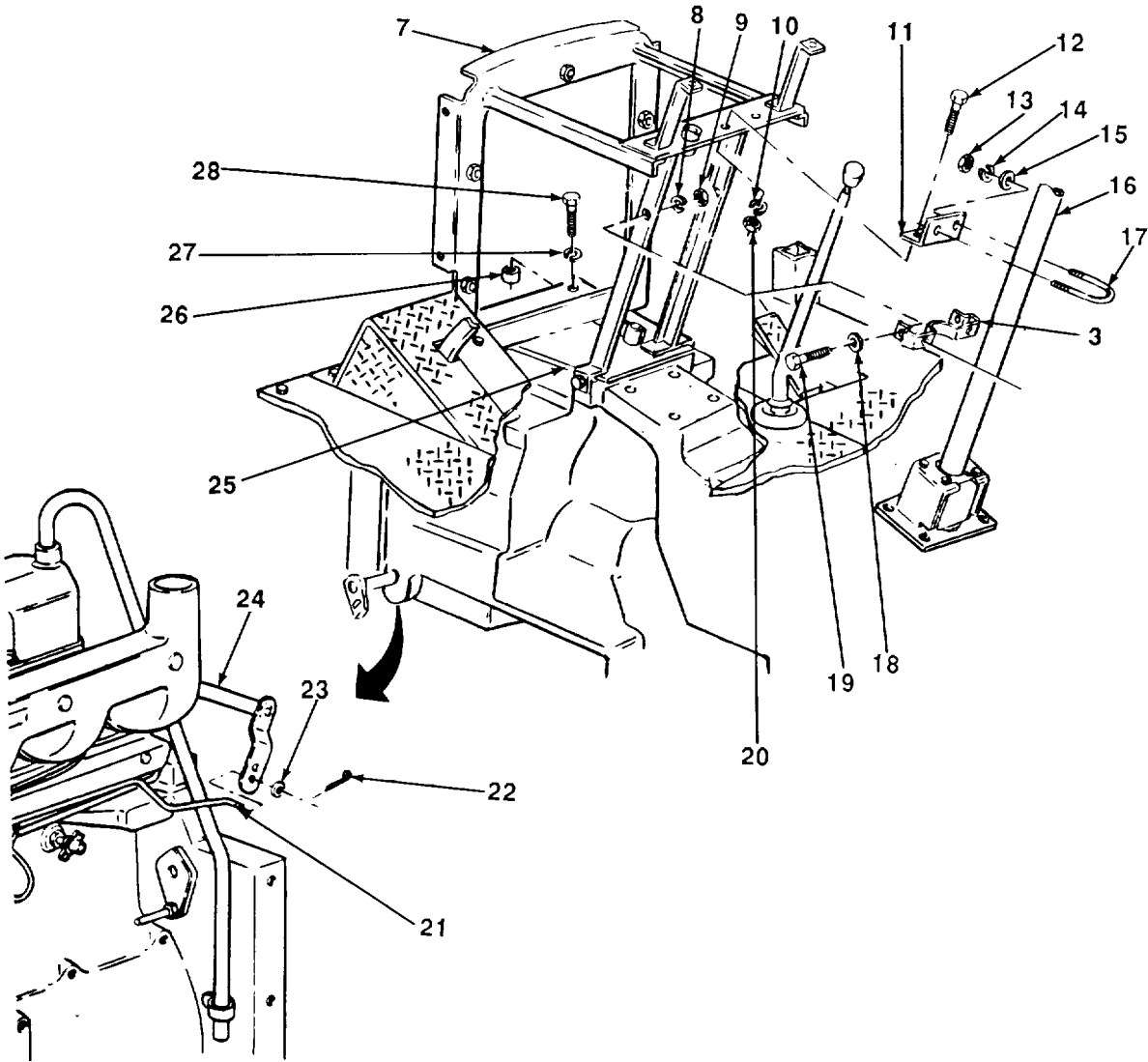

TA701528

13-5. COWL SUPPORT MAINTENANCE (Con't).**NOTE**

Some loader backhoes may not have hanger and retaining strap. If parts are not present, skip steps 7 and 8.

7. Install two capscrews (19), washers (18), new lockwashers (8), nuts (9), and hanger (3) on steering column (16) and cowl support (7).
8. Install two capscrews (6), washers (5) new lockwashers (2), nuts (1), and retaining strap (4) on hanger (3).

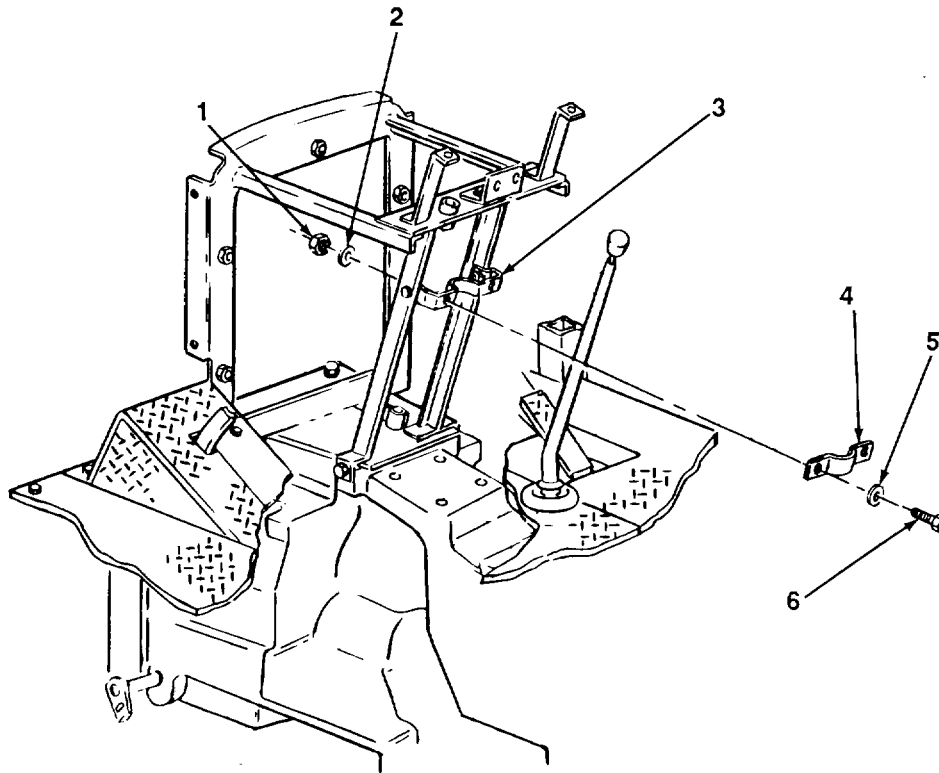
**FOLLOW-ON TASKS:**

- Install parking brake relay (see TM 5-2420-222-20).
- Install electric horn and bracket (see TM 5-2420-222-20).
- Install circuit breakers (see TM 5-2420-222-20).
- Install accelerator pedal, foot accelerator rod, and speed control arms (see TM 5-2420-222-20).
- Install reverser control lever (see TM 5-2420-222-20).

TA701529

13-6 FENDERS AND SUPPORTS MAINTENANCE.

This Task Covers:

- | | | |
|----------------------------|----|-----------------|
| a. Removal | d. | Assembly |
| b. Disassembly | | e. Installation |
| c. Cleaning and Inspection | | |
-

Initial Setup:

Equipment Conditions:

- Combined tail and stoplight removed (see TM 5-2420-222-20).
- Combined tail and floodlight removed (see TM 5-2420-222-20).
- Loader backhoe control guards removed (see TM 5-2420-222-20).
- Rear light wiring harness removed (see TM 5-2420-222-200)
- Stoplight wiring harness removed (see TM 5-2420-222-20).

NOTE

Perform the following only if removing right fender.

- Center platform removed (see TM 5-2420-222-20).
- Loader backhoe control box door removed (see TM 5-2420-222-20).

NOTE

Perform the following only if removing left fender.

- Warning alarm wiring harness removed (see TM 5-2420-222-20).
-

Materials/Parts:

- Metal bonding adhesive (Item 1, Appendix B)
- Detergent (Item 13, Appendix B)
- Rags (Item 28, Appendix B)
- Dry cleaning solvent (Item 31, Appendix B)
- Lacing and tying tape (Item 37, Appendix B)
- One special nut
- Twenty-six lockwashers
- Twenty-six lockwashers
- Electrical tie-down straps (as required)

Tools/Test Equipment:

- General mechanic's tool kit
- Field automotive shop set

Personnel Required: Two

General Safety Instructions:

- Dry cleaning solvent is flammable and must not be used near open flame. Use only in a well-ventilated area.

NOTE

Both fenders and supports are maintained the same way. Left side is shown. Repeat procedure for right side unless otherwise noted.

13-6 FENDERS AND SUPPORTS MAINTENANCE (Con't).

a. REMOVAL

WARNING

Use extreme caution when handling heavy parts. Lifting device is required when parts weigh over 50 lb (23 kg) for a single person lift, over 100 lb (45 kg) for a two person lift, and over 150 lb (68 kg) for a three or more person lift. Keep clear of heavy parts supported only by lifting device. Failure to follow this warning may cause serious injury or death to personnel.

1. Using lifting device, support fender (1).
2. Remove four capscrews (8), washers (13), lockwashers (14), and nuts (15) from structural frame (16) and fender brace (5). Discard lockwashers,

NOTE

Loader backhoes with serial numbers 235786-235999 have a canopy. Loader backhoes with serial numbers 319995-342573 have a roll-over protective structure (ROPS).

3. Remove six capscrews (9), washers (10), lockwashers (11), and nuts (12) from fender (1) and canopy or ROPS (6). Discard lockwashers.

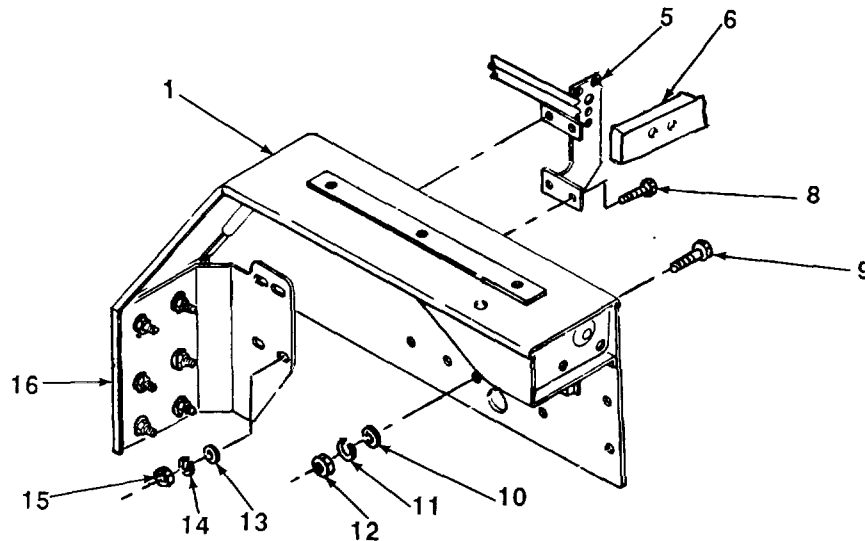

TA701530

13-6 FENDERS AND SUPPORTS MAINTENANCE (Con't).**NOTE**

If removing left fender, skip steps 4 and 5.

4. Remove bolt (17), lockwasher (23), and nut (22) from control box (18), throttle lever bracket (24), and fender (1). Discard lockwasher.
5. Remove five bolts (19), lockwashers (20), and nuts (21) from control box (18) and fender (1). Discard lockwashers.

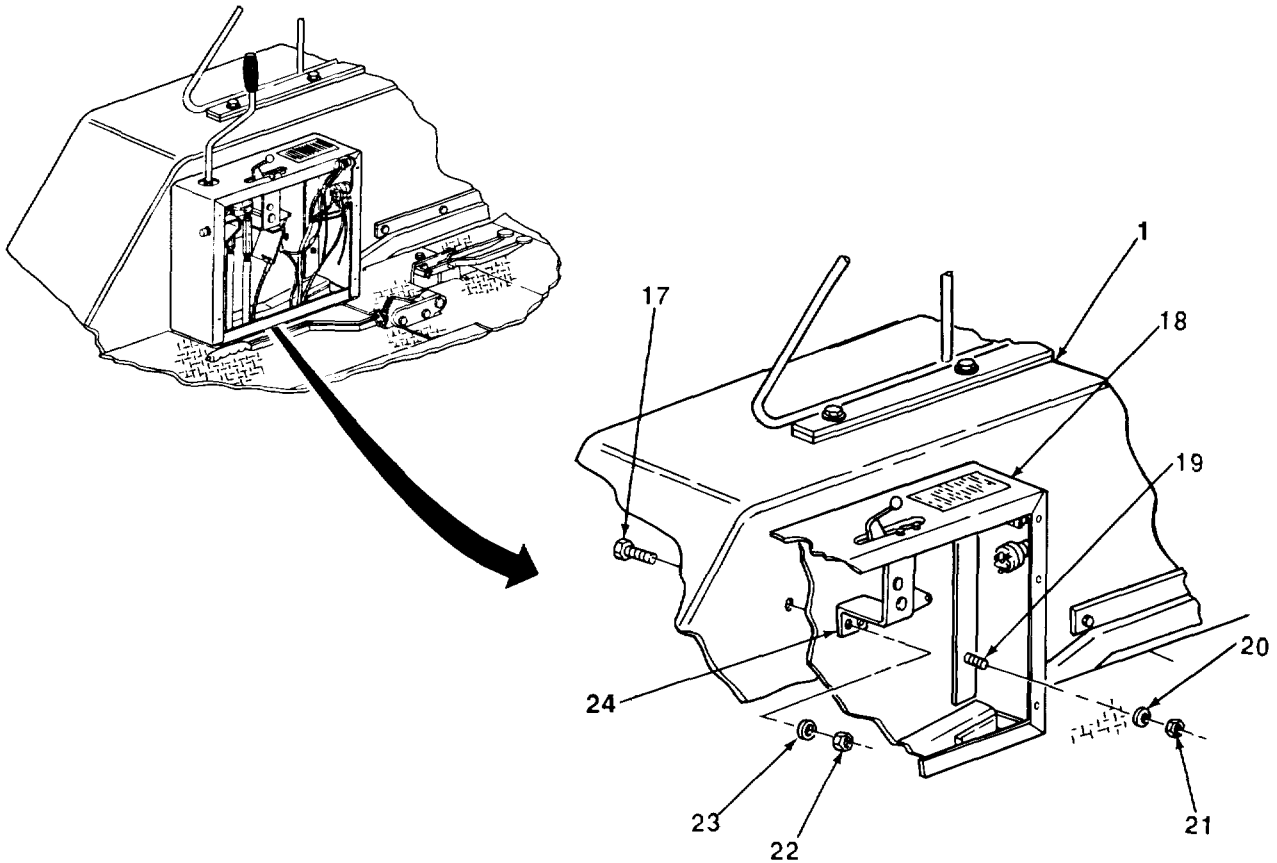

TA701531

13-6 FENDERS AND SUPPORTS MAINTENANCE (Con't).

WARNING

Use extreme caution when handling heavy parts. Lifting device is required when parts weigh over 50 lb (23 kg) for a single person lift, over 100 lb (45 kg) for a two person lift, and over 150 lb (68 kg) for a three or more person lift. Keep clear of heavy parts supported only by lifting device. Failure to follow this warning may cause serious injury or death to personnel.

6. Using lifting device, remove fender (1) with assembled parts from fender brace (5) and canopy or ROPS (6).
7. Remove two screws (7), washers (4), lockwashers (3), and nuts (2) from fender brace (5), and canopy or ROPS (6). Discard lockwashers.
8. Remove fender brace (5).

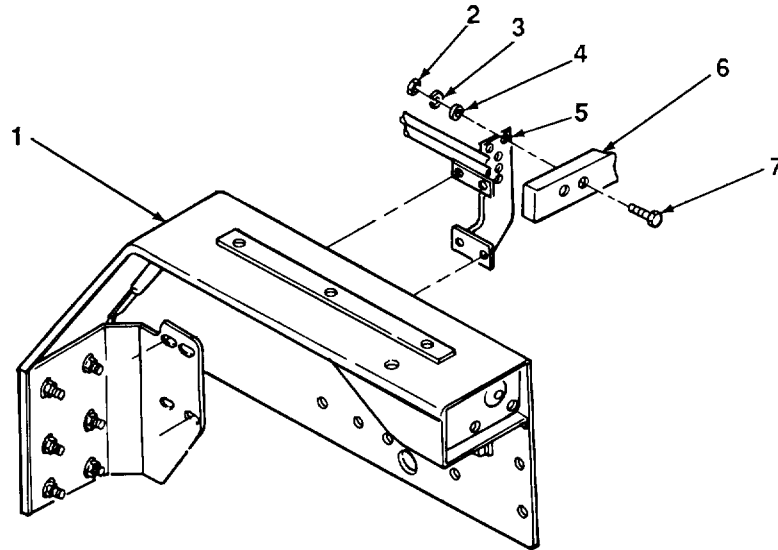

TA701532

13-6 FENDERS AND SUPPORTS MAINTENANCE (Con't).

b. DISASSEMBLY**NOTE**

If disassembling left fender, skip step 1.

1. Remove six capscrews (29), lockwashers (33), washers (32), nuts (34), and structural frame (16) from fender (1). Discard lockwashers.

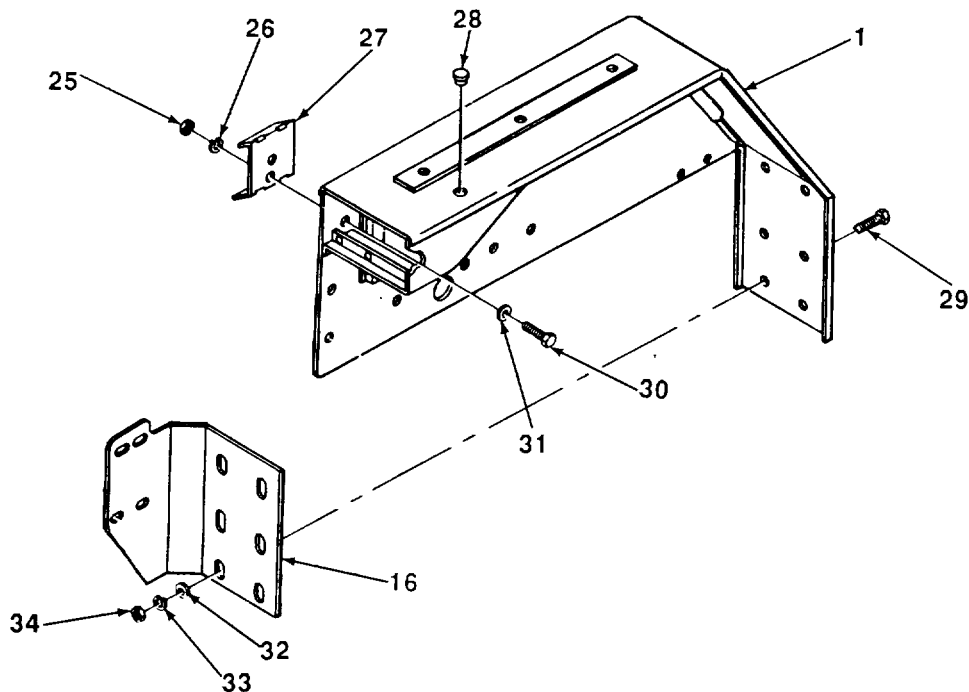
**NOTE**

If disassembling right fender, skip steps 2 through 4.

2. Remove four capscrews (40), washers (42), lockwashers (43), nuts (44), and step (41) from fender (1). Discard lockwashers.
3. Remove two capscrews (39), washers (47), lockwashers (46), nuts (45), and structural frame (16) from fender (1). Discard lockwashers.
4. Remove two capscrews (36), four washers (37), and handle (38) from fender (1).
5. Remove six capscrews (48) and lampholder (35) from fender (1).

TA701533

13-6 FENDERS AND SUPPORTS MAINTENANCE (Con't).

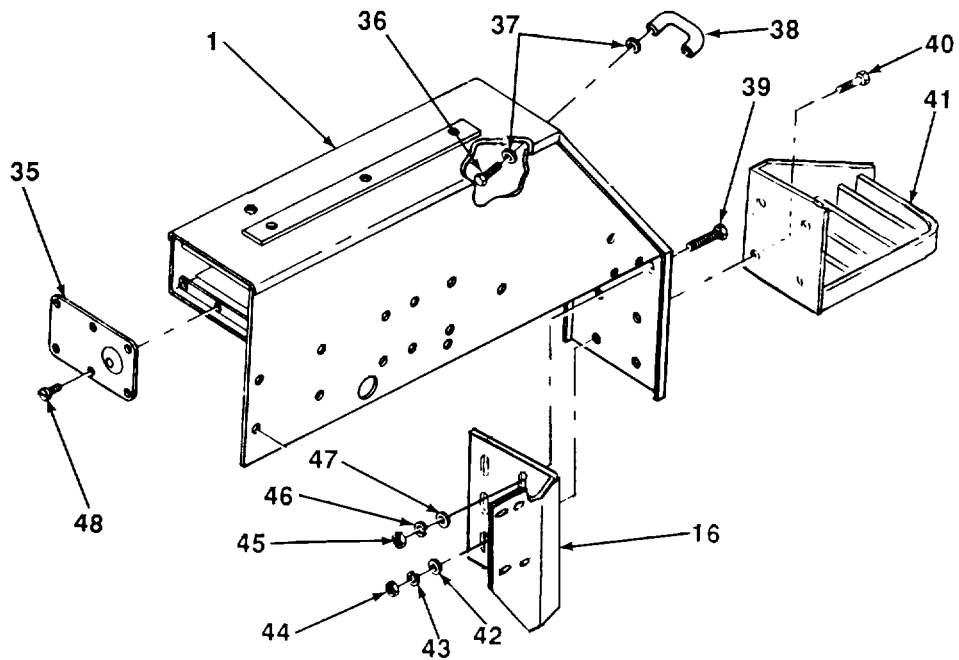

NOTE
If disassembling left fender, skip step 6.

6. Remove two cap screws (30), washers (31), lockwashers (26), nuts (25), and bracket (27) from fender (1). Discard lockwashers.
7. Pry button plug (28) out of fender (1).

TA701534

13-6 FENDERS AND SUPPORTS MAINTENANCE (Con't).

WARNING

Dry cleaning solvent, P-D-680, is toxic and flammable. Always wear protective goggles and gloves, and use only in a well-ventilated area. Avoid contact with skin, eyes, and clothes, and DO NOT breathe vapors. DO NOT use near open flame or excessive heat. The solvent's flash point is 100°F-138°F (38°C-59°C). If you become dizzy while using cleaning solvent, immediately get fresh air and medical help. If solvent contacts eyes, immediately wash your eyes and get medical aid.

CAUTION

Do not remove liner section unless damaged. Removal may damage liner section.

NOTE

Step 8 applies only to loader backhoes with serial numbers 319995-342573

8. Lift up corner of liner section (49) and dissolve adhesive with rags and dry cleaning solvent. Continue to wet with dry cleaning solvent until liner section is completely off fender (1).
9. Clean adhesive off fender (1) with dry cleaning solvent and clean rags. Rinse with clean water and dry thoroughly.

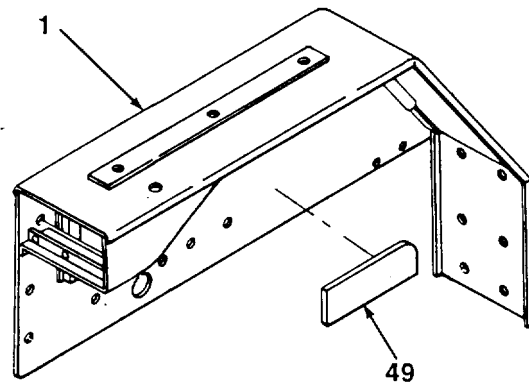
**c. CLEANING AND INSPECTION**

1. Clean fender and assembled parts with rag dampened in water and detergent solution. Rinse with clean water and dry thoroughly.

WARNING

Dry cleaning solvent, P-D-680, is toxic and flammable. Always wear protective goggles and gloves, and use only in a well-ventilated area. Avoid contact with skin, eyes, and clothes, and DO NOT breathe vapors. DO NOT use near open flame or excessive heat. The solvent's flash point is 100°F-138°F (38°C-59°C). If you become dizzy while using cleaning solvent, immediately get fresh air and medical help. If solvent contacts eyes, immediately wash your eyes and get medical aid.

2. Clean all other metal parts with dry cleaning solvent and rags. Dry thoroughly with clean, dry rags.
3. Inspect all metal parts for cracks, breaks, and abnormal bends.

TA701535

13-6. FENDERS AND SUPPORTS MAINTENANCE (Con't).

4. Inspect fender for damaged threads. Restore damaged threads using screw threading set.
5. Inspect liner section for cracks, rips, tears, and crumbling.

d. ASSEMBLY**NOTE**

Perform steps 1 and 2 only on loader backhoes with serial numbers 319995-342573, if liner section was removed.

1. Apply metal bonding adhesive in Y in. (3.18 mm) wide beads in 2 in. (50.80 mm) or smaller squares on liner section (49). Ensure that outside bead has no gaps and is within 1/4 in. (6.35 mm) from edge of liner section.
2. Press liner section (49) in place on fender (1), then remove and allow adhesive to set for two minutes. Aline liner section with fender and press firmly in place.
3. Press button plug (28) in place in fender (1).

NOTE

If assembling left fender, skip step 4.

4. Position bracket (27) in place on fender (1) and secure with two capscrews (30), washers (31), new lockwashers (26), and nuts (25).

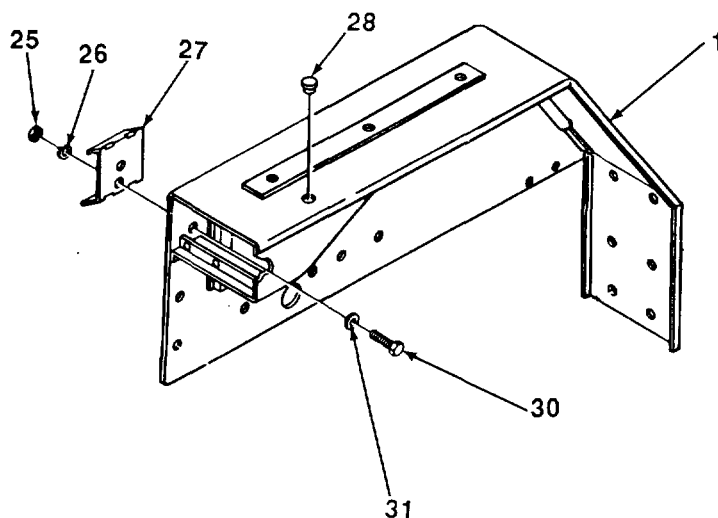

TA701536

13-6. FENDERS AND SUPPORTS MAINTENANCE (Con't).

- 5. Position lampholder (35) in place on fender (1) and secure with six capscrews (48).

NOTE
If assembling right fender, skip steps 6 through 8.

- 6. Position handle (38) in place on fender (1) and secure with two capscrews (36) and four washers (37).
- 7. Position structural frame (16) in place on fender (1) and secure with two capscrews (39), washers (47), new lockwashers (46), and nuts (45).
- 8. Position step (41) in place on fender (1) and secure with four capscrews (40), washers (42), new lockwashers (43), and nuts (44).

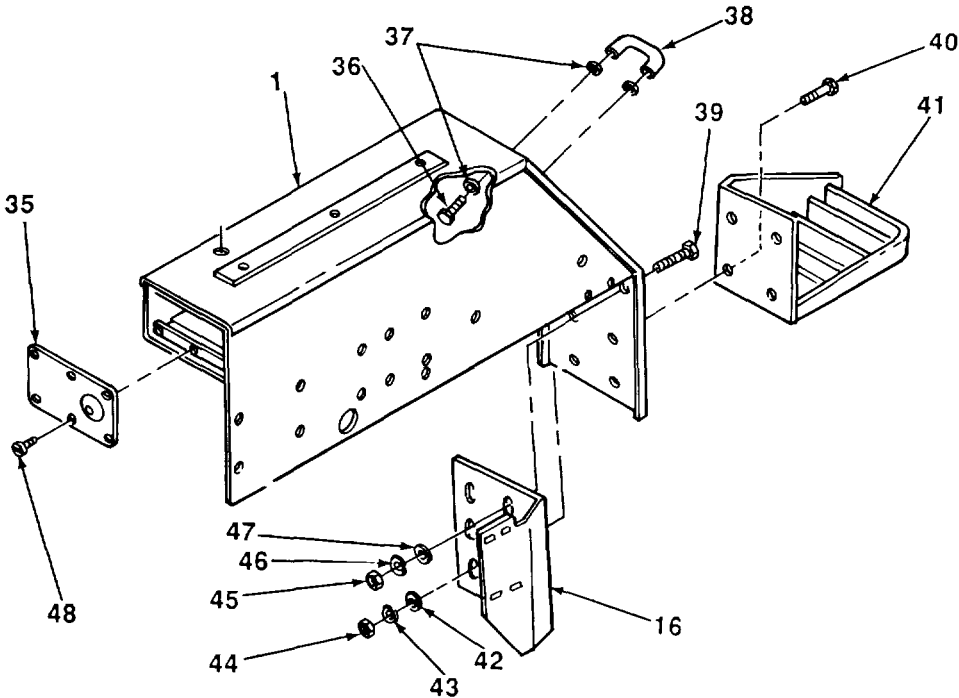

TA701537

13-6. FENDERS AND SUPPORTS MAINTENANCE (Con't).

NOTE
If assembling left fender, skip step 9.

- 9. Position structural frame (16) in place on fender (1) and secure with six cap screws (29), washers (32), new lockwashers (33), and nuts (34).

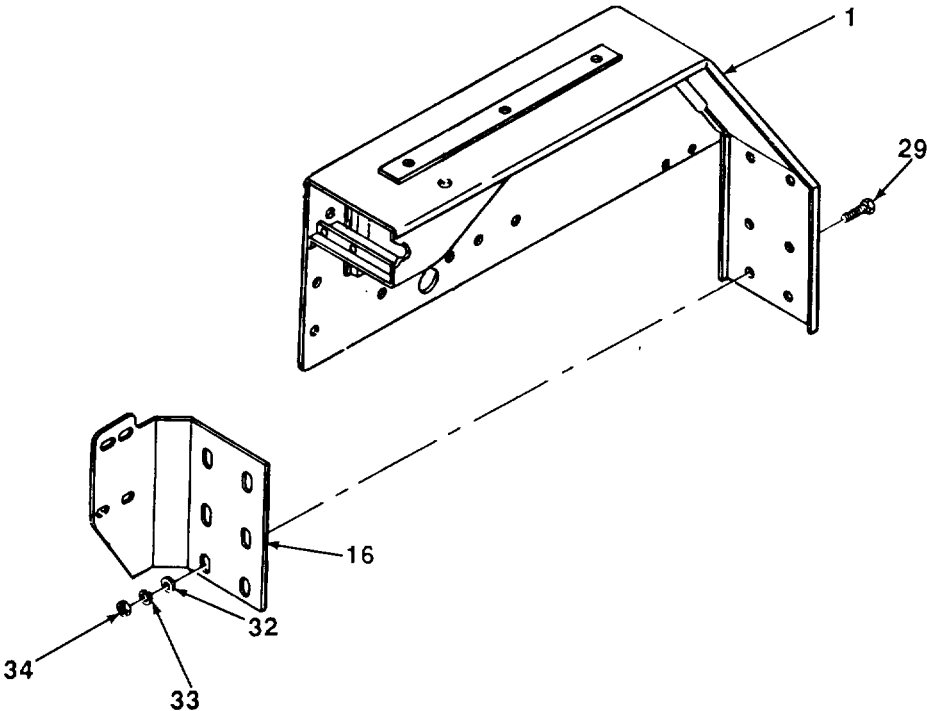

13-6. FENDERS AND SUPPORTS MAINTENANCE (Con't).

e. INSTALLATION

WARNING

Use extreme caution when handling heavy parts. Lifting device is required when parts weigh over 50 lb. (23 kg) for a single person lift, over 100 lb. (45 kg) for a two person lift, and over 150 lb. (68 kg) for a three or more person lift. Keep clear of heavy parts supported only by lifting device. Failure to follow this warning may cause serious injury or death to personnel.

NOTE

Loader backhoes with serial numbers 235786-235999 have a canopy. Loader backhoes 319995-342573 have a roll-over protective structure (ROPS).

1. Install fender brace (5) on fender (1) and canopy or ROPS (6).
2. Install two screws (7), washers (4), new lockwashers (3), and nuts (2) in fender brace (5) and canopy or ROPS (6).
3. Using lifting device, raise and position fender (1) and assembled parts on fender brace (5) and canopy or ROPS (6).

NOTE

If installing left fender, skip steps 4 and 5.

4. Install five bolts (19), new lockwashers (20), and nuts (21) in control box (18) and fender (1).
5. Install bolt (17), new lockwasher (23), and nut (22) in control box (18), throttle lever bracket (24), and fender (1).

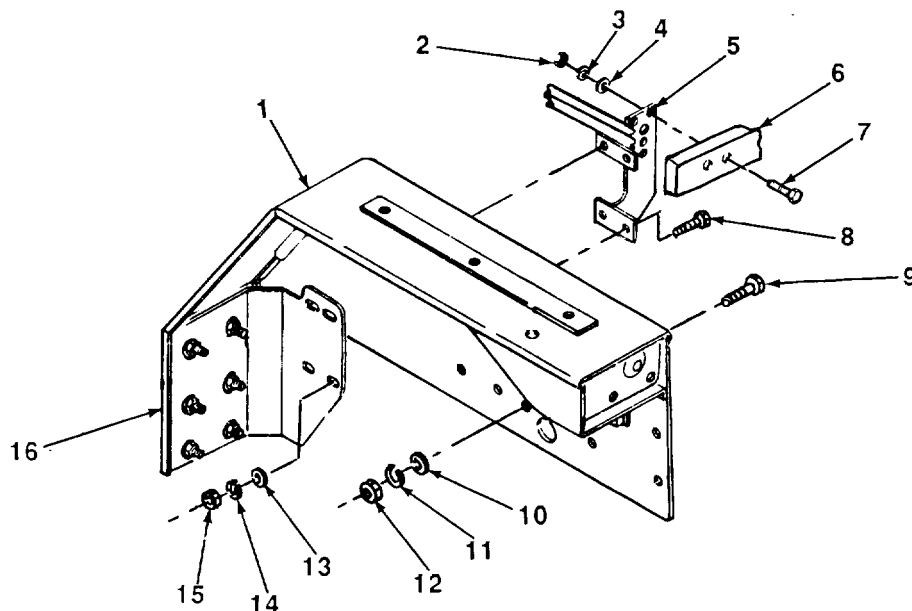

TA701539

13-6. FENDERS AND SUPPORTS MAINTENANCE (Con't).

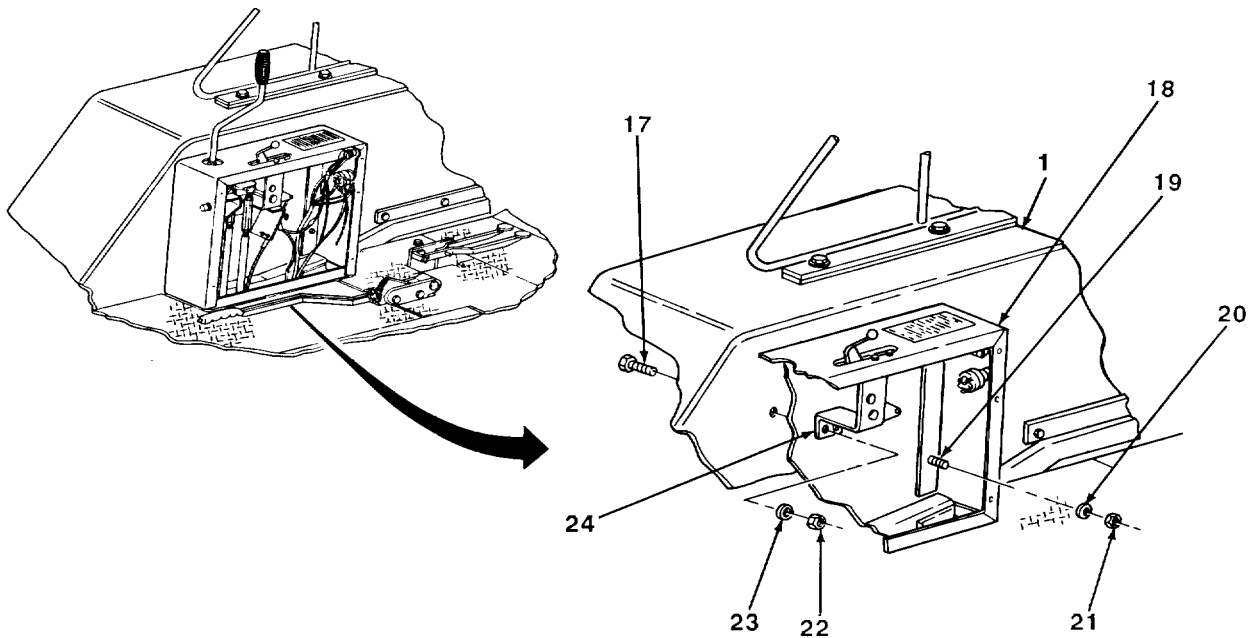

6. Install six cap screws (9), washers (10), new lockwashers (11), and nuts (12) in fender (1) and canopy or ROPS (6).
7. Install four cap screws (8), washers (13), new lockwashers (14), and nuts (15) in structural frame (16) and fender brace (5).
8. Remove lifting device from fender (1).

FOLLOW-ON TASKS:

NOTE

Perform the following only if right fender was removed.

- Install loader backhoe control box door (see TM 5-2420-222-20).
- Install center platform (see TM 5-2420-222-20). NOTE

NOTE

Perform the following only if left fender was removed.

- Install warning alarm wiring harness (see TM 5-2420-222-20).

NOTE

Perform the following if right or left fender was removed.

- Install stoplight wiring harness (see TM 5-2420-222-20).
- Install rear light wiring harness (see TM 5-2420-222-20).
- Install combined tail and floodlight (see TM 5-2420-222-20).
- Install combined tail and stoplight (see TM 5-2420-222-20).
- Install loader backhoe control guards (see TM 5-2420-222-20).

CHAPTER 14
HYDRAULIC SYSTEM MAINTENANCE

Paragraph Number	Paragraph Title	Page Number
14-1	Hydraulic System Test	14-2
14-2	Accumulator Assembly Maintenance	14-7
14-3	Hydraulic Pump Assembly Maintenance	14-13
14-4	Hydraulic Pump Drive Shaft and Coupler Maintenance (Serial Numbers 235786-235999)	14-26
14-5	Hydraulic Pump Drive Shaft and Coupler Maintenance (Serial Numbers 319995-342573)	14-29
14-6	Hydraulic Pump Stroke Control Valve Repair	14-32
14-7	Hydraulic Pump Stroke Control Valve Solenoid Replacement.....	14-38
14-8	Jaw Control Valve Assembly Repair	14-40
14-9	Backhoe Control Valve Assembly Repair.....	14-45
14-10	Backhoe Stabilizer and Bucket Valves Repair	14-50
14-11	Backhoe Crowd Valve Repair	14-56
14-12	Backhoe Boom and Swing Valves Repair.....	14-60
14-13	Backhoe Relief Valves Maintenance.....	14-66
14-14	Loader Control Valve Assembly Repair	14-72
14-15	Loader Boom and Bucket Valves Repair	14-74
14-16	Loader Bucket Relief Valves Maintenance.....	14-80
14-17	Hydraulic Hoses, Lines, and Fittings Repair	14-84
14-18	Jaw Cylinder Assembly Repair.....	14-84
14-19	Backhoe Crowd Cylinder Assembly Repair.....	14-88
14-20	Backhoe Boom Cylinder Assembly Repair.....	14-94
14-21	Backhoe Bucket Cylinder Assembly Repair.....	14-99
14-22	Backhoe Swing Cylinder Assemblies Repair	14-106
14-23	Backhoe Stabilizer Cylinder Assemblies Repair	14-111
14-24	Loader Bucket Cylinder Assemblies Repair.....	14-116
14-25	Loader Boom Cylinder Assemblies Repair.....	14-120

14-1. HYDRAULIC SYSTEM TEST.*This Task Covers: Test**Initial Setup:***Tools/Test Equipment:**

- General mechanic's tool kit
- Field automotive shop set
- Hydraulic system tester

Materials/Parts:

- Rags (Item 28, Appendix B)

References:

- TM 5-2420-222-10
- TM 5-2420-222-20

TEST**WARNING**

- **Do not attempt to disconnect hydraulic hoses and fittings while engine is running or before hydraulic system pressure has been released. When engine is running, hydraulic system is under pressure. Hydraulic system pressure should be 0 psi (0 kPa) before lines are disconnected. A line or fitting disconnected under pressure will spray hydraulic fluid with force and may cause serious injury to personnel.**
- **Be careful when draining hot fluids. Wear gloves to protect your hands from hot parts and fluids. Severe burns could result.**

NOTE

- **Purpose of test is to give indication of no flow condition for entire hydraulic system. Flow indication from hydraulic system tester will require hydraulic components to be isolated and checked for leakage.**
- **Backhoe test may be isolated by performing steps 14 through 39 and connecting the hydraulic system tester to the backhoe.**
- **Use a drain pan to catch fluid when disconnecting hydraulic hoses. Clean up all spills.**

1. Release hydraulic system pressure (see TM 5-2420-222-20).
2. Disconnect hose (1) from special tee (2).
3. Connect hydraulic system tester to hose (1) and special tee (2).
4. Start engine assembly and run at 2500 rpm (see TM 5-2420-222-10). Run engine until operating temperature is 170-F-190-F (77°C-88°C).
5. Check connections of hydraulic system tester, hose (1), and special tee (2) for leaks. Tighten any leaking connections.
6. Position all loader backhoe hydraulic levers in neutral (see TM 5-2420-222-10).
7. Check hydraulic system tester for indication of no flow. If flow is present, individual components must be isolated and checked for leakage.
8. Shut down engine assembly (see TM 5-2420-222-10).

14-1. HYDRAULIC SYSTEM TEST (Con't).

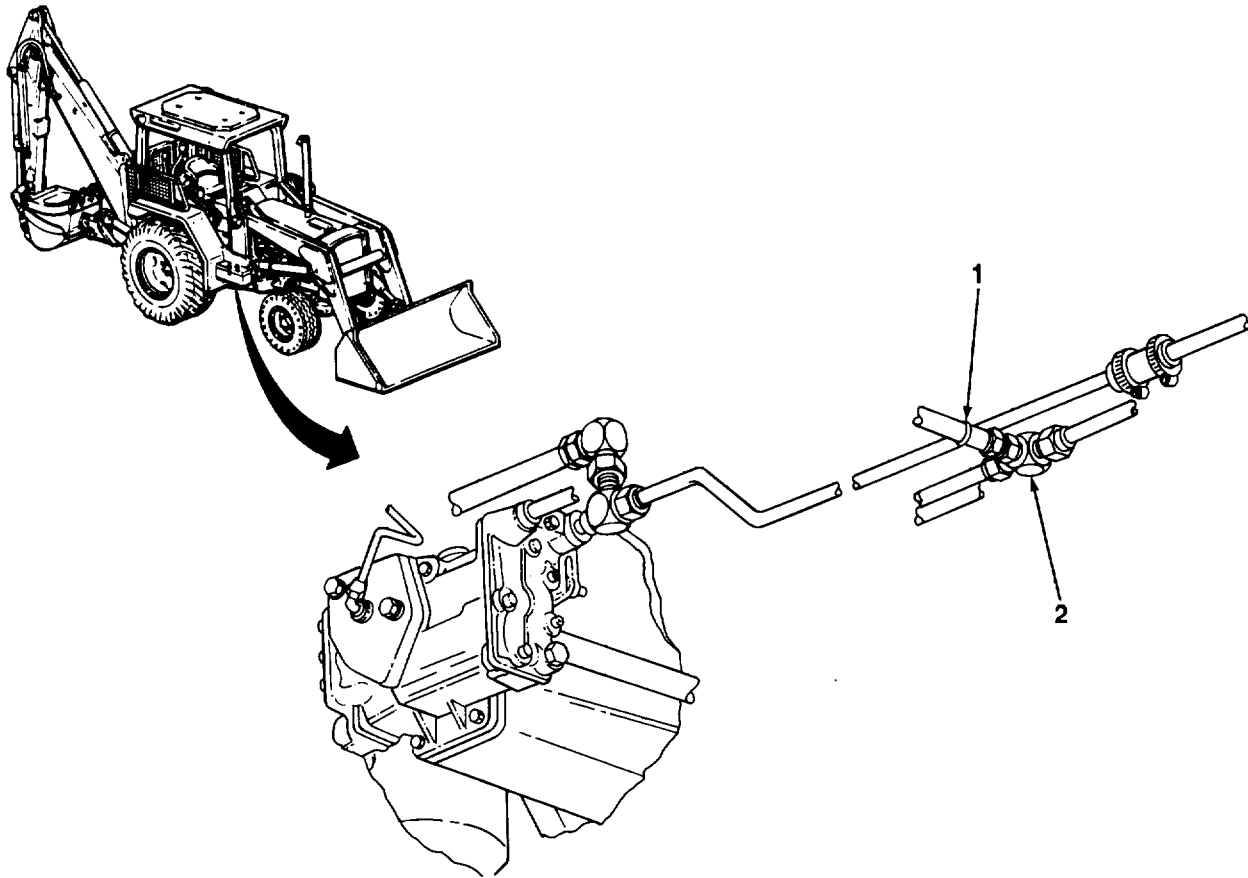

9. Release hydraulic system pressure (see TM 5-2420-222-20)
10. Disconnect and remove hydraulic system tester from hose (1) and special tee (2).
11. Connect hose (1) to special tee (2).
12. Start engine assembly (see TM 5-2420-222-10) and check hose (1) and special tee (2) for leaks. Tighten any leaking connections.
13. Shut down engine assembly (see TM 5-2420-222-10).

NOTE

Backhoe test may be isolated by installing hydraulic system tester between pressure and return circuits.

14. Remove backhoe valve box (see TM 5-2420-222-20).

TA701541

14-1. HYDRAULIC SYSTEM TEST (Con't).

NOTE

Steps 15 through 18 apply only to loader backhoes with serial numbers 235786-235999.

15. Disconnect return hose fitting (3) from adapter (4).
16. Connect hydraulic system tester to return hose fitting (3) and adapter (4).
17. Disconnect pressure hose fitting (6) from adapter (5).
18. Connect hydraulic system tester to pressure hose fitting (6) and adapter (5).

NOTE

Steps 19 through 22 apply only to loader backhoes with serial numbers 319995-342573.

19. Disconnect return hose fitting (8) from adapter (7).
20. Connect hydraulic system tester to return hose fitting (8) and adapter (7).
21. Disconnect pressure hose fitting (9) from adapter (10).
22. Connect hydraulic system tester to pressure hose fitting (9) and adapter (10).
23. Start engine assembly and idle at 2500 rpm (see TM 5-2420-222-10). Run engine assembly until operating temperature is 170° F-190°F (77°C-88°C).
24. Check all connections between hydraulic system tester and backhoe for leaks. Tighten any leaking
25. Check hydraulic system tester for indication of no flow. If flow is present, individual components must be isolated and checked for leakage.
26. Shut down engine assembly (see TM 5-2420-222-10).
27. Release hydraulic system pressure (see TM 5-2420-222-20).

NOTE

Steps 28 through 31 apply only to loader backhoes with serial numbers 235786-235999.

28. Disconnect hydraulic system tester from return hose fitting (3) and adapter (4).
29. Connect return hose fitting (3) to adapter (4).
30. Disconnect hydraulic system tester from pressure hose fitting (6) and adapter (5).
31. Connect pressure hose fitting (6) to adapter (5).

NOTE

Steps 32 through 35 apply only to loader backhoes with serial numbers 319995-342573.

32. Disconnect hydraulic system tester from return hose fitting (8) and adapter (7).

14-1. HYDRAULIC SYSTEM TEST (Con't).

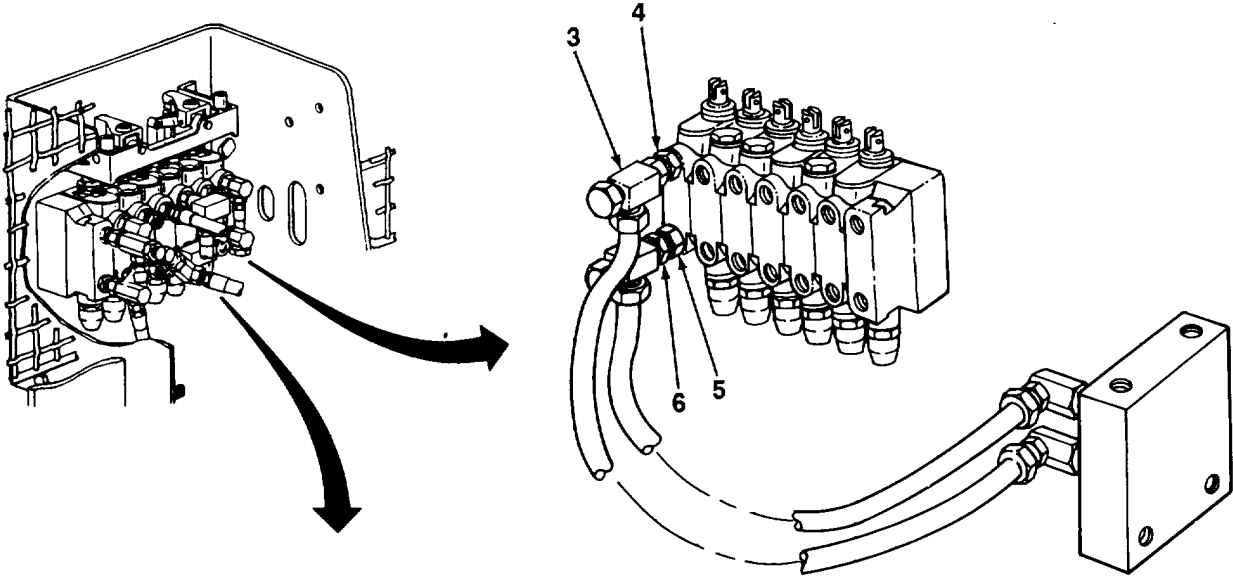

SERIAL NUMBERS
235786-235999

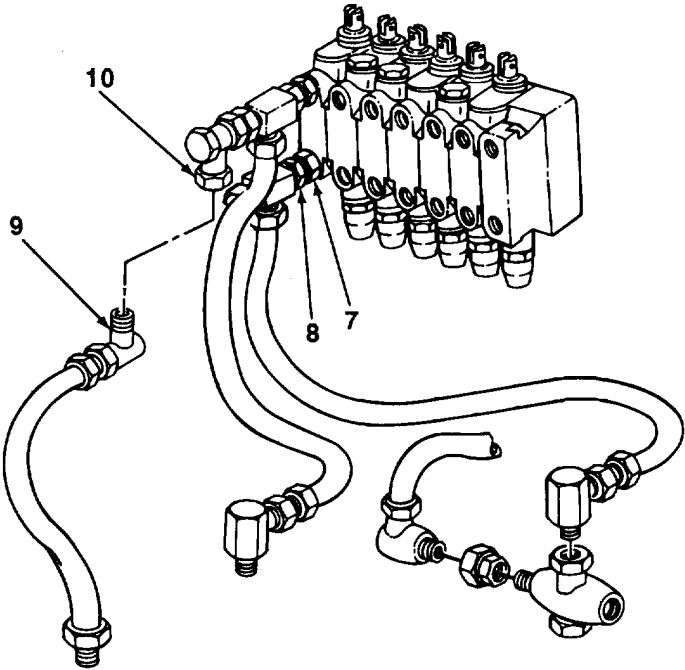

SERIAL NUMBERS
319995-342573

14-1. HYDRAULIC SYSTEM TEST (Con't).

33. Connect return hose fitting (8) to adapter (7).
34. Disconnect hydraulic system tester from pressure hose fitting (9) and adapter (10).
35. Connect pressure hose fitting (9) to adapter (10).
36. Start engine assembly and idle at 2500 rpm (see TM 5-2420-222-10). Run engine assembly until operating temperature is 1700F-1900F (77°C-88 °C).
37. Check all connections between hydraulic system and loader backhoe for leaks. Tighten any leaking connections.
38. Shut down engine assembly (see TM 5-2420-222-10).
39. Install backhoe valve box (see TM 5-2420- 222-20).

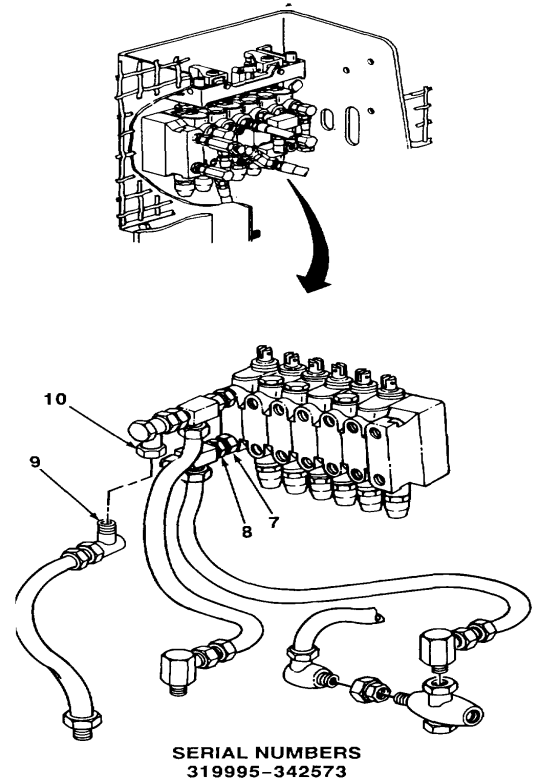

14-2. ACCUMULATOR ASSEMBLY MAINTENANCE.

This Task Covers:

- | | |
|----------------------------|-----------------|
| a. Removal | d. Repair |
| b. Disassembly | e. Assembly |
| c. Cleaning and Inspection | f. Installation |
-

*Initial Setup:***Equipment Conditions:**

- Pump pressure line-to-tee disconnected (see TM 5-2420-222-20).
- Steering pressure hose-to-tee disconnected (see TM 5-2420-222-20).
- Hydraulic accumulator oil line tee removed (see TM 5-2420-222-20).

Tools/Test Equipment:

- General mechanic's tool kit
- Field automotive shop set

Materials/Parts:

- Hydraulic fluid (Item 15, Appendix B)
- Rags (Item 28, Appendix B)
- Dry cleaning solvent (Item 31, Appendix B)
- One gasket
- Two ring spacers
- Three packing retainers
- Five preformed packings
- Seven lockwashers

General Safety Instructions:

- Dry cleaning solvent is flammable and must not be used near open flame. Use only in a well-ventilated area.
-

14-2. ACCUMULATOR ASSEMBLY MAINTENANCE (Con't).

a. REMOVAL

1. Remove two capscrews (12) and lockwashers (11) from bracket (15) and cap (10). Discard lockwashers.
2. Remove capscrew (9), lockwasher (2), nut (1), and clamp (7) from hydraulic cylinder (8) and bracket (15). Discard lockwasher.
3. Remove hydraulic cylinder (8) from bracket (15).
4. Remove four capscrews (13), lockwashers (14), and bracket (15) from right canopy special bracket (16). Discard lockwashers.

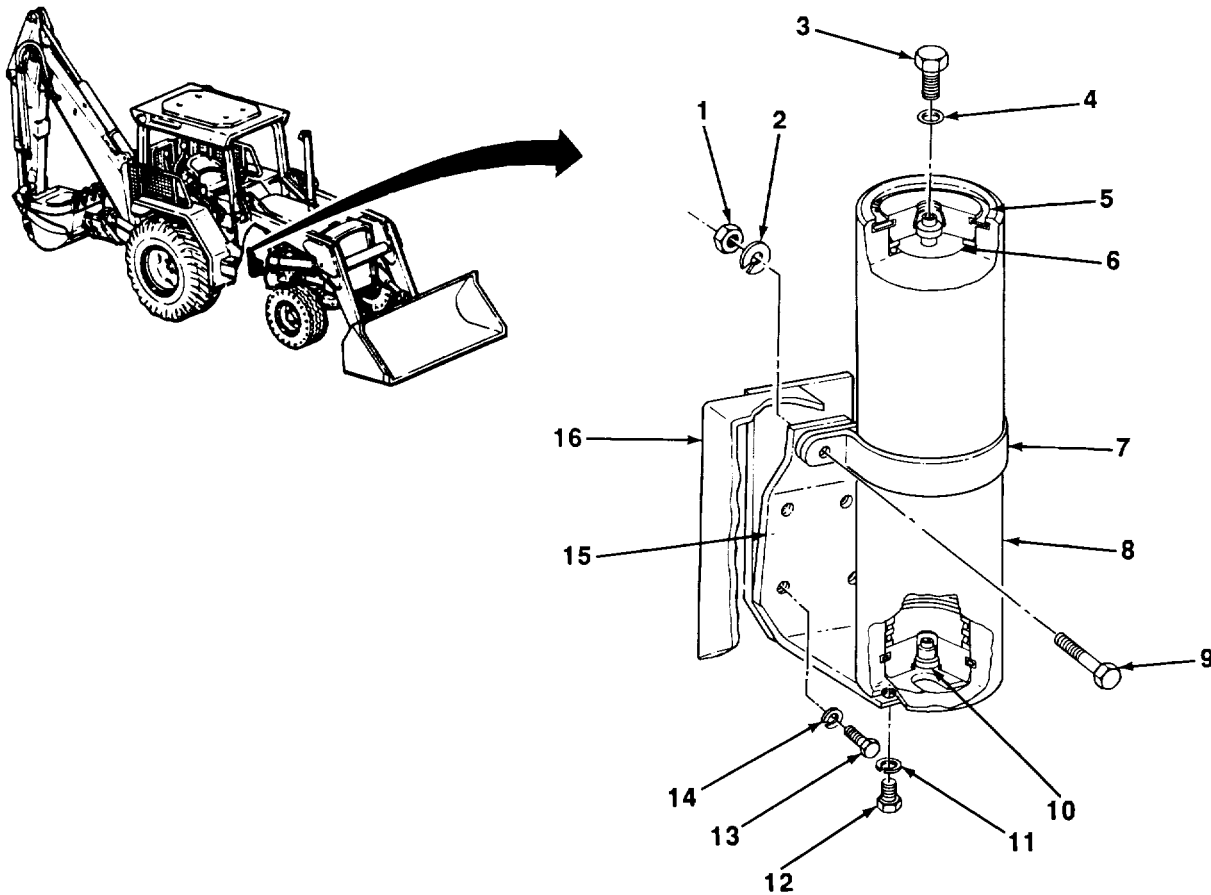

TA701544

14-2. ACCUMULATOR ASSEMBLY MAINTENANCE (Con't).

b. DISASSEMBLY

WARNING

Ensure that nitrogen gas pressure has been bled from accumulator before disassembly. Accumulator left under pressure may explode and cause serious injury or death to personnel.

1. Remove plug (3) and preformed packing (4) from end cap (5). Discard preformed packing.
2. Using flat-tip screwdriver, push down on control valve body (6) in end cap (5) and release pressure.
3. Using retaining ring pliers, remove retaining ring (19) from hydraulic cylinder (8) and cap (10).
4. Slide cap (10) with assembled parts out of hydraulic cylinder (8).
5. Remove preformed packing (21), ring spacer (20), spring (18), and fluid restrictor (17) from cap (10). Discard preformed packing and ring spacer.

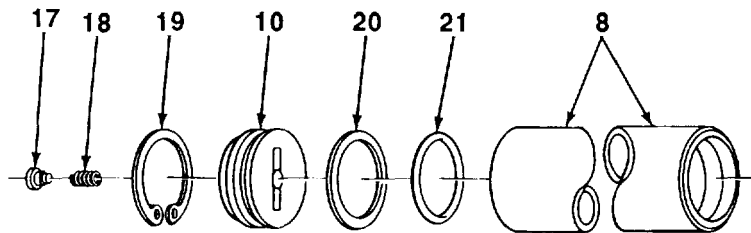

6. Using retaining ring pliers, remove retaining ring (29) from hydraulic cylinder (8) and end cap (5).
7. Slide end cap (5) with assembled parts out of hydraulic cylinder (8).
8. Remove preformed packing (27), ring spacer (28), seat (22), spring (23), control valve body (24), sleeve spacer (25), and gasket (26) from end cap (5). Discard preformed packing, ring spacer, and gasket.

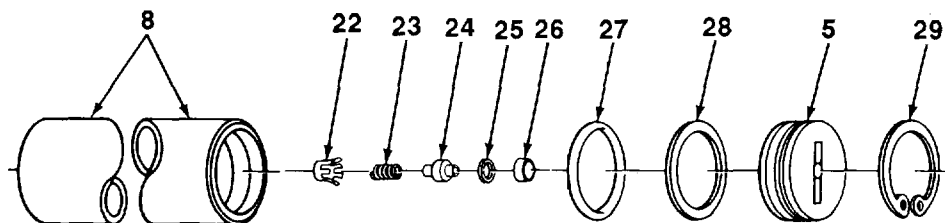

TA701545

14-2. ACCUMULATOR ASSEMBLY MAINTENANCE (Con't).

9. Slide piston (32) with assembled parts out of hydraulic cylinder (8).
10. Remove two packing retainers (33), preformed packings (31), and packing retainer (30) from piston (32). Discard preformed packings and packing retainers.

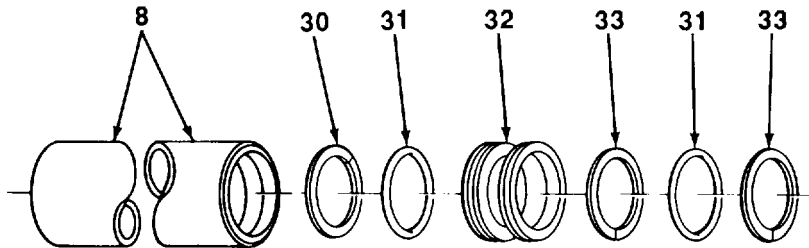
**c. CLEANING AND INSPECTION****WARNING**

Dry cleaning solvent, P-D-680, is toxic and flammable. Always wear protective goggles and gloves, and use only in a well-ventilated area. Avoid contact with skin, eyes, and clothes, and DO NOT breathe vapors. DO NOT use near open flame or excessive heat. The solvent's flash point is 100°F-1380F (380C-590C). If you become dizzy while using cleaning solvent, immediately get fresh air and medical help. If solvent contacts eyes, immediately wash your eyes and get medical aid.

1. Clean all metal parts with dry cleaning solvent and rags. Dry thoroughly with clean, dry rags.
2. Inspect all metal parts for cracks, breaks, and abnormal bends.
3. Inspect end cap and cap for damaged threads.
4. Inspect inner diameter of hydraulic cylinder for scratches, nicks, and excessive wear.
5. Inspect end cap, cap, control valve body, and piston for scratches, nicks, and excessive wear.
6. Inspect retaining rings for deformity or breaks.

d. REPAIR

Restore damaged end cap (5) or cap threads using screw threading set.

e. ASSEMBLY

1. Coat new gasket (26) with hydraulic fluid. Install in end cap (5).
2. Install sleeve spacer (25), control valve body (24), spring (23), and seat (22) in place on end cap (5).

TA701546

14-2. ACCUMULATOR ASSEMBLY MAINTENANCE (Con't).

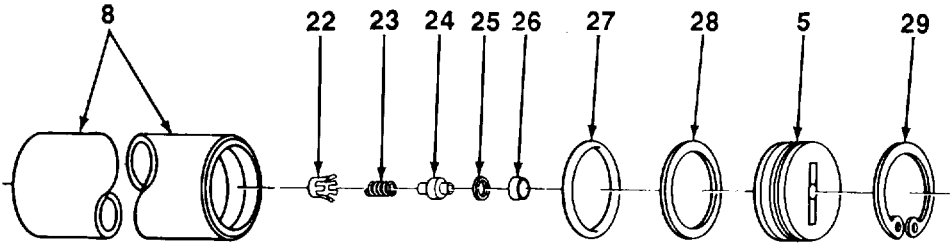

3. Coat new preformed packing (27) and new ring spacer (28) with hydraulic fluid. Install on end cap (5).
4. Slide end cap (5) with assembled parts in hydraulic cylinder (8) until retaining ring groove is visible.
5. Using retaining ring pliers, install retaining ring (29) in hydraulic cylinder (8) and against end cap (5).
6. Coat two new packing retainers (33), new preformed packings (31), and new packing retainer (30) with hydraulic fluid and install on piston (32).
7. Slide piston (32) with assembled parts in hydraulic cylinder (8) with open end facing fluid side of hydraulic cylinder.
8. Install spring (18) and fluid restrictor (17) in cap (10).
9. Coat new ring spacer (20) and new preformed packing (21) with hydraulic fluid. Install on cap (10).
10. Slide cap (10) with assembled parts in hydraulic cylinder (8) until retaining ring groove is visible.
11. Using retaining ring pliers install retaining ring (19) in hydraulic cylinder (8) and against cap (10).

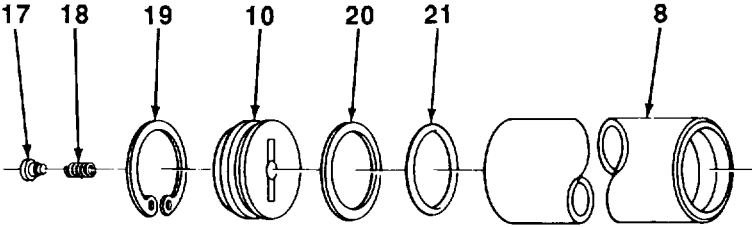

14-2. ACCUMULATOR ASSEMBLY MAINTENANCE (Con't).

12. Install plug (3) and new preformed packing (4) in end cap (5).

f. INSTALLATION

1. Position bracket (15) in place on right canopy special bracket (16) and secure with four capscrews (13) and new lockwashers (14).
2. Position clamp (7) in place on hydraulic cylinder (8).
3. Position hydraulic cylinder (8) and clamp (7) in place on bracket (15). Install capscrew (9), new lockwasher (2), and nut (1) in clamp and bracket.
4. Install two capscrews (12) and new lockwashers (11) in bracket (15) and cap (10).

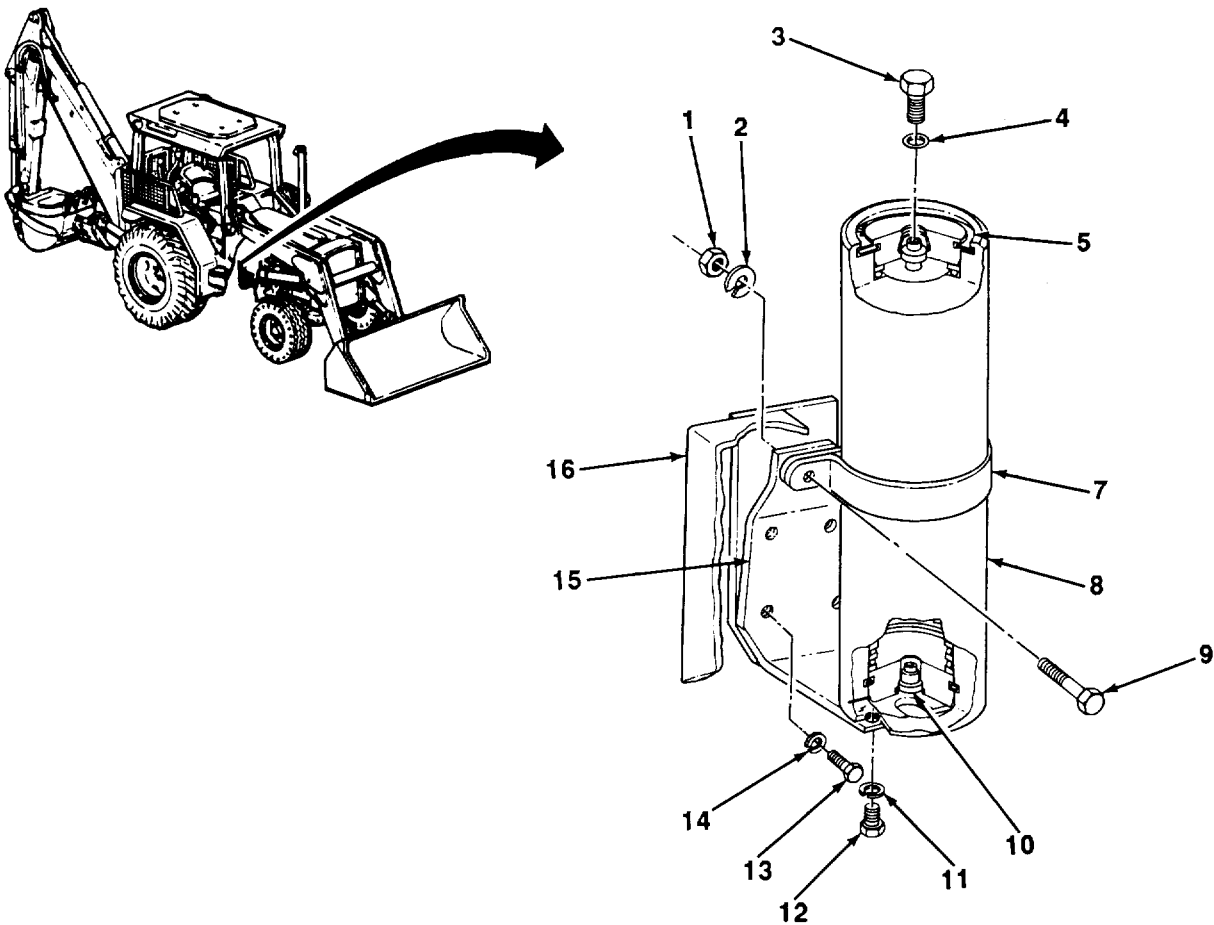
**FOLLOW-ON TASKS:**

- Install hydraulic accumulator oil line tee (see TM 5-2420-222-20)
- Connect steering pressure hose-to-tee (see TM 5-2420-222-20).
- Connect pump pressure line-to-tee (see TM 5-2420-222-20).
- Charge hydraulic accumulator (see TM 5-2420-222-20).

TA701548

14-3. HYDRAULIC PUMP ASSEMBLY MAINTENANCE.

This Task Covers:

- | | | | |
|----|-------------------------|----|--------------|
| a. | Removal | d. | Assembly |
| b. | Disassembly | e. | Installation |
| c. | Cleaning and Inspection | e. | Adjustment |
-

*Initial Setup:***Equipment Conditions:**

- Hood removed (see TM 5-2420-222-20).
- Fuel tank removed (see TM 5-2420-222-20).
- Pressure control valve oil line disconnected (see TM 5-2420-222-20).
- Clutch control valve inlet oil line disconnected (see TM 5-2420-222-20).
- Speed gear assembly (reverser) seal drain line disconnected (see TM 5-2420-222-20).
- Oil cooler line disconnected (see TM 5-2420-222-20).
- Hydraulic pump stroke control valve solenoid removed (see paragraph 14-7).

Tools/Test Equipment:

- General mechanic's tool kit
 - Field automotive shop set
 - Hydraulic system tester
 - Two drivers
-

Materials/Parts:

- Hydraulic fluid (Item 15, Appendix B)
- Rags (Item 28, Appendix B)
- Dry cleaning solvent (Item 31, Appendix B)
- One parts kit

References:

- LO 5-2420-222-12
- TM 5-2420-222-10
- TM 5-2420-222-20
- TM 9-214

General Safety Instructions:

- Dry cleaning solvent is flammable and must not be used near open flame. Use only in a well-ventilated area.
-

14-3. HYDRAULIC PUMP ASSEMBLY MAINTENANCE (Con't).

a. REMOVAL

1. Loosen two screws (2) on hydraulic pump drive shaft.
2. Remove four screws (5), stroke control valve (4), and hydraulic pump (3) from bracket (1).

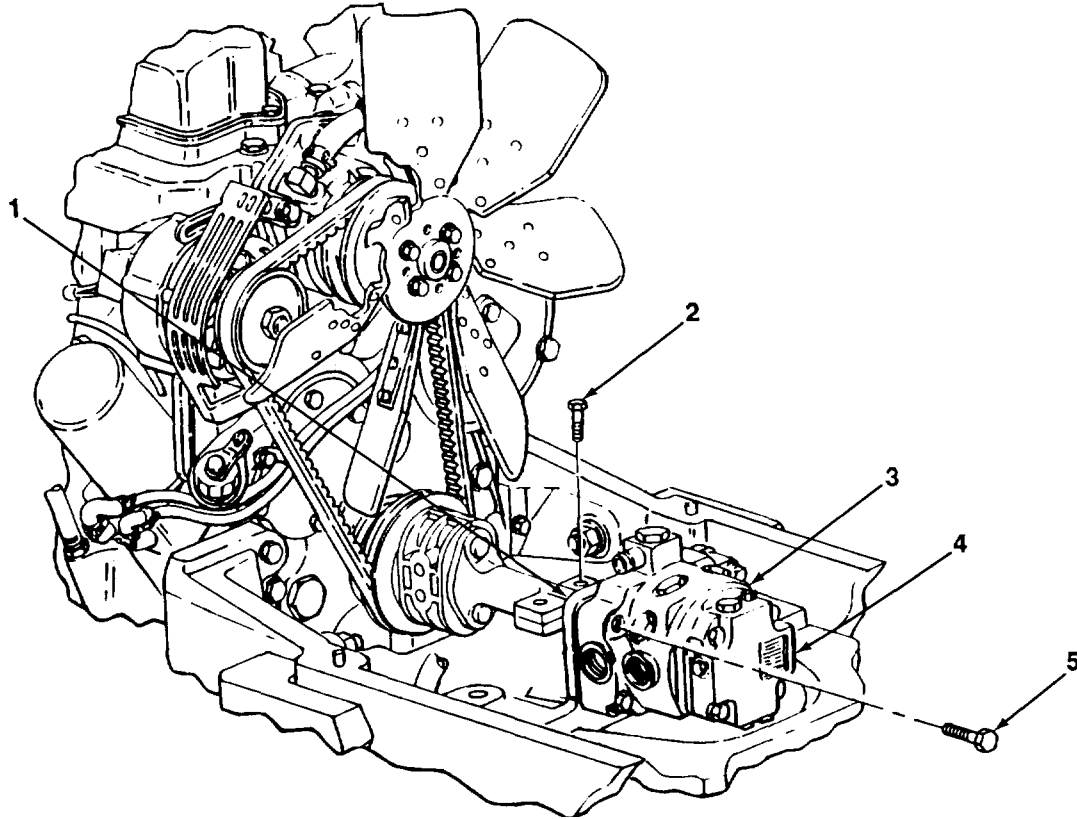

3. Match-mark stroke control valve (4) and hydraulic pump (3). Remove four screws (6) and stroke control valve from hydraulic pump.

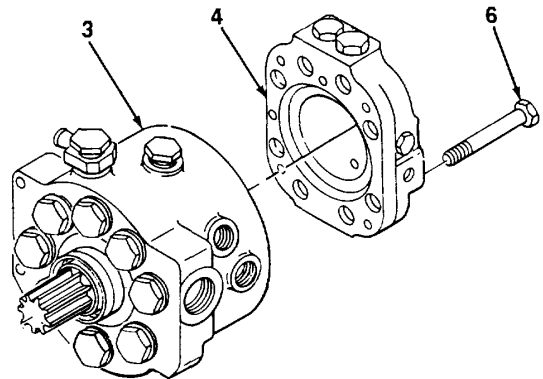

TA701549

14-3. HYDRAULIC PUMP ASSEMBLY MAINTENANCE (Con't).

b. DISASSEMBLY

NOTE

Preformed packings may have been removed when adapter and elbow were removed.

1. Remove preformed packings (14 and 15) from hydraulic pump housing (13). Discard preformed packings.
2. Remove plug (24) and preformed packing (23). Discard preformed packing.
3. Remove plug (7), preformed packing (27), elbow (26), and preformed packing (25). Discard preformed packings.
4. Remove eight plugs (8), preformed packings (9), springs (10), pistons (11), and sheaths (12). Discard preformed packings.
5. Remove eight plugs (20) and preformed packing (21). Discard preformed packings.
6. Using inlet valve removal tool, remove eight inlet valves (22).
7. Remove retaining ring (19), oil seal (18), backup ring (17), and quad ring packing (16). Discard quad ring packing, backup ring, and oil seal.

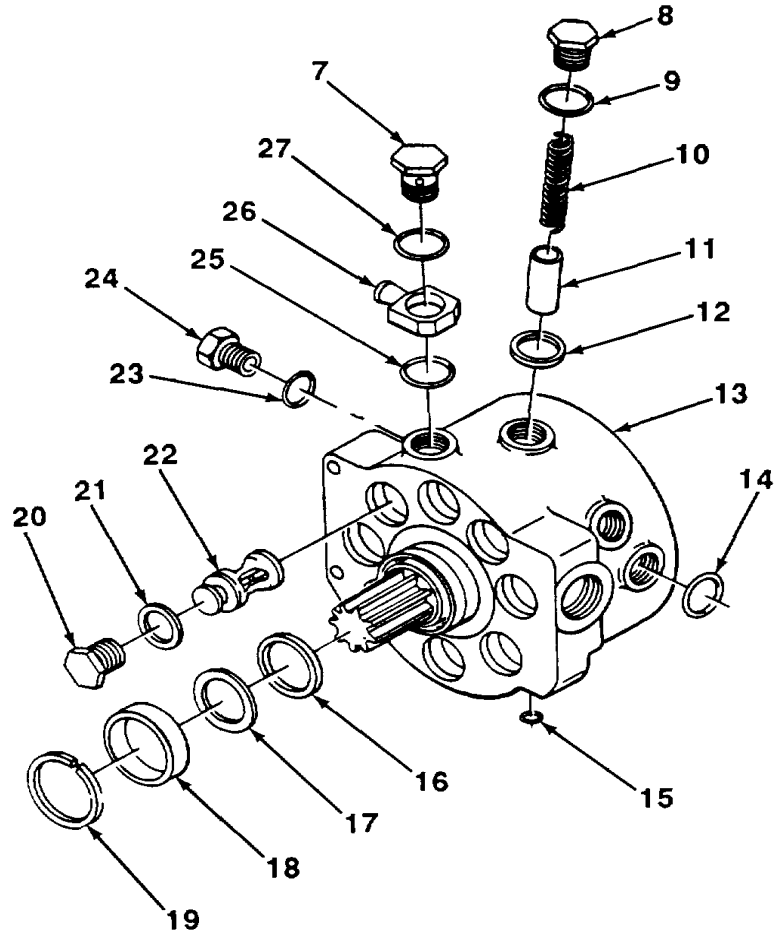

TA701550

14-3. HYDRAULIC PUMP ASSEMBLY MAINTENANCE (Con't).

8. Remove eight discharge packings (33), valve stops (32), guides (31), springs (30), and outlet valves (29). Discard discharge packings.
9. If damaged, remove eight valve seats (28).

NOTE

Number of shims may vary. Note quantity removed to ensure proper installation.

10. Remove shim(s) (35).
11. Tap shaft (36) from hydraulic pump housing (13) and remove bearing cup (34).

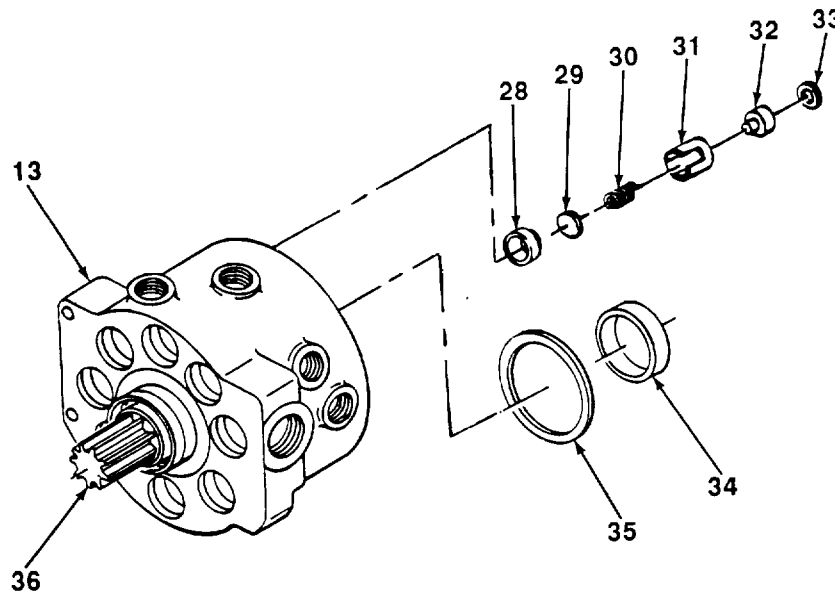
**NOTE**

**Loader backhoes with serial numbers 319995-342573 have bearing washers.
Loader backhoes with serial numbers 235786-235999 do not.**

13. Remove bearing washer (43), outer bearing ring (42), and 25 roller bearings (41) from shaft (36).
14. Remove cone and rollers (37), washer (38), and bearing washer (39) from shaft (36).
15. Remove bearing washer (40) from shaft (36).

TA701551

14-3. HYDRAULIC PUMP ASSEMBLY MAINTENANCE (Con't).

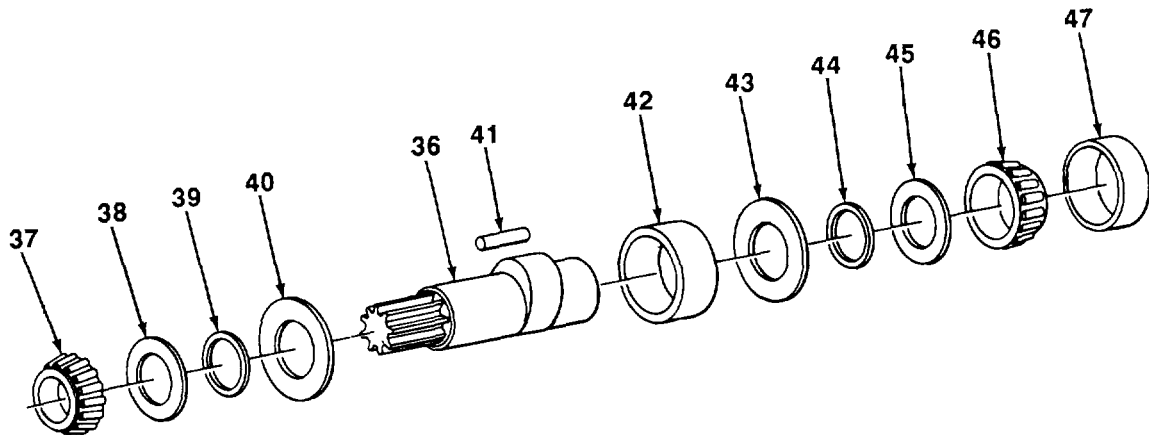
c. **CLEANING AND INSPECTION****WARNING**

Dry cleaning solvent, P-D-680, is toxic and flammable. Always wear protective goggles and gloves, and use only in a well-ventilated area. Avoid contact with skin, eyes, and clothes, and DO NOT breathe vapors. DO NOT use near open flame or excessive heat. The solvent's flash point is 100°F-138°F (38°C-59°C). If you become dizzy while using cleaning solvent, immediately get fresh air and medical help. If solvent contacts eyes, immediately wash your eyes and get medical aid.

1. Clean all metal parts with dry cleaning solvent. Dry thoroughly with clean, dry rags.
2. Inspect roller bearings (see TM 9-214).
3. Inspect hydraulic pump housing for cracks and breaks.
4. Inspect hydraulic pump housing for scoring and excessive wear. Using telescoping gage, measure inside diameter of bore where eight discharge packings and valve seats were removed. Measurement must read 1.385-1.387 in. (35.179-35.230 mm).
5. Inspect hydraulic pump housing oil seal bore for excessive wear. Using telescoping gage, measure inside diameter. Measurement must read 2.011-2.021 in. (51.080-51.334 mm).
6. Inspect hydraulic pump housing bearing bore for excessive wear. Using telescoping gage, measure Inside diameter. Measurement must read 3.3745-3.3755 in. (85.7123-85.7377 mm).
7. Inspect eight hydraulic pump housing piston bores. Using telescoping gage, measure inside diameter. Measurement must read 0.9637-0.9643 in. (24.4780-24.4932 mm).
8. Inspect eight hydraulic pump housing Inlet valve bores. Using telescoping gage, measure Inside diameter. Measurement must read 0.9995-1.0005 in. (25.3873-25.4127 mm).
9. Inspect eight hydraulic pump housing outlet valve bores. Using telescoping gage, measure Inside diameter. Measurement must read 0.6245-0.6255 in. (15.8623-15.8877 mm).

TA701552

14-3. HYDRAULIC PUMP ASSEMBLY MAINTENANCE (Con't).

10. Inspect eight pistons (11) for scoring and pitting. Using caliper, measure outside diameter of pistons. Measurement must read 0.9360-0.9634 in. (23.7744-24.4704 mm).
11. Using spring tester and torque wrench, check eight springs (10). If springs compress less than 47 lb.-ft. (64 N•m), require more than 53 lb.-ft. (72 N•m), or vary more than 1.5 lb.-ft. (2 N•m), replace springs.
12. Inspect eight inlet valves (22) for looseness. Using depth gage, measure lift. Measurement must read 0.0600-0.0820 in. (1.5240-2.0828 mm).
13. Using caliper, measure outside diameter of shaft (36). Measurement must read 1.7442-1.7448 in. (44.3027-44.3179 mm).
14. Using telescoping gage, measure inside diameter of outer bearing ring (42). Measurement must read 2.2458-2.2465 in. (57.0408-57.0611 mm). Using caliper, measure outside diameter. Measurement must read 2.814-2.816 in. (71.476-71.526 mm).

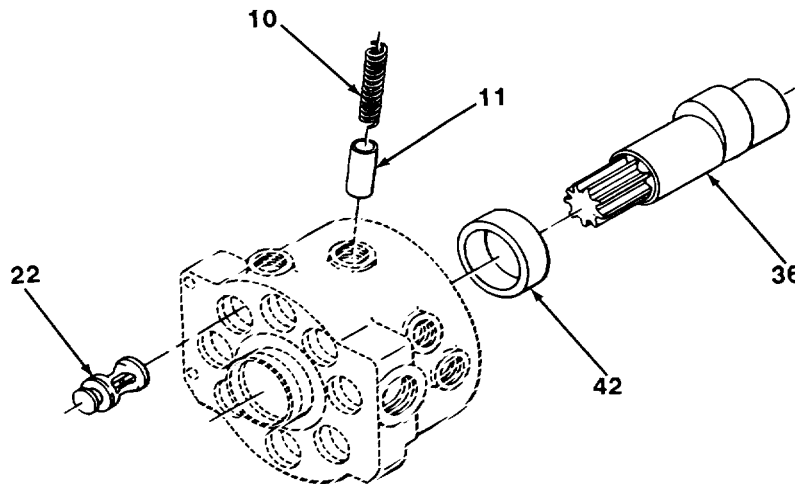

d. ASSEMBLY

1. Install new quad ring packing (16) and new backup ring (17) in hydraulic pump housing (13).

CAUTION

Do not install oil seal beyond retaining ring groove. Improper installation will cause leakage when hydraulic pump is assembled.

2. Using driver, install new oil seal (18) in hydraulic pump housing (13).
3. Install retaining ring (19) in groove in hydraulic pump housing (13).
4. Using installer and arbor press, install bearing cup (34) until seated in hydraulic pump housing (13).

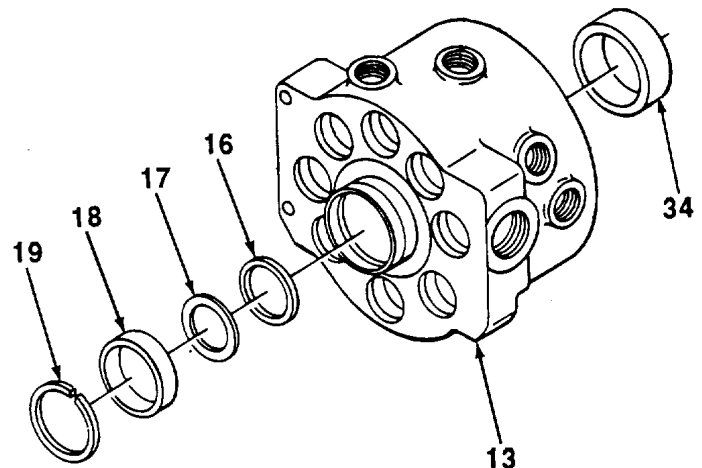

14-3. HYDRAULIC PUMP ASSEMBLY MAINTENANCE (Con't).

- 5. Install bearing washers (43 and 44) and washer (45) on shaft (36).
- 6. Using installer and arbor press, install cone and rollers (46) until seated on shaft (36).
- 7. Position outer bearing ring (42) over shaft (36). Coat 25 roller bearings (41) with hydraulic fluid, and insert roller bearings between outer bearing ring and shaft.
- 8. Install bearing washer (40), bearing washer (39), and washer (38) on shaft (36).
- 9. Using installer and arbor press, Install cone and rollers (37) until seated on shaft (36).

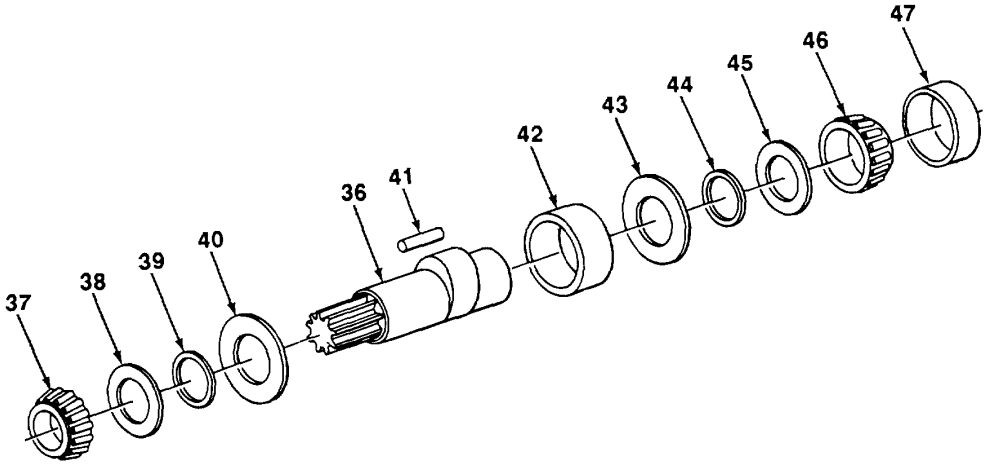

- 10. Install shaft (36) in hydraulic pump housing (13).
- 11. Install bearing cup (47) in hydraulic pump housing (13).

CAUTION

Ensure that no more than 850 lb (386 kg) of pressure are used when installing valve seats. Equipment may be damaged.

- 12. If removed, install eight valve seats (28) in hydraulic pump housing (13) using arbor press.
- 13. Using depth micrometer gage, measure distance from surface of hydraulic pump housing (13) to shoulder of valve seats (28). Distance must be at least 0.870 in. (22.098 mm).

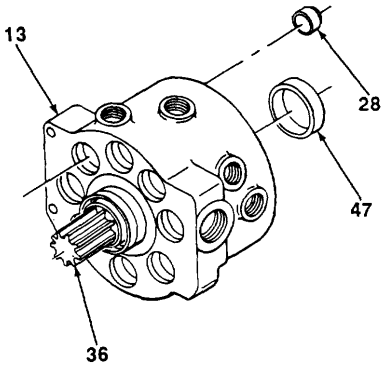

14-19

14-3. HYDRAULIC PUMP ASSEMBLY MAINTENANCE (Con't).

14. Apply thin coat of hydraulic fluid to eight inlet valves (22) and insert inlet valves in hydraulic pump housing (13).
15. Install eight new preformed packings (21) on plugs (20) and install plugs in hydraulic pump housing (13).

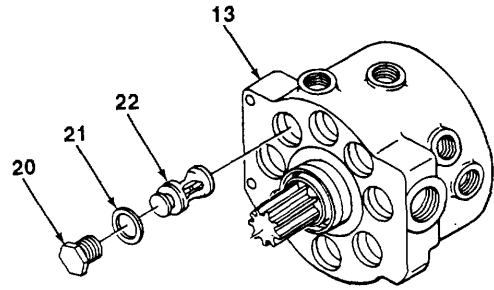
**NOTE**

- Ensure that all packings are installed in stroke control valve before installing stroke control valve on hydraulic pump.
- Install same number of shim(s) as removed.

16. Install shim(s) (35) and stroke control valve (4) with packings on hydraulic pump housing (13) with four screws (6). Torque screws to 85 lb.-ft. (115 N-m).
17. Using dial indicator, measure end play of shaft (36). End play must be 0.001-0.003 in. (0.025-0.076 mm). If end play is within specification, perform step 18 and skip steps 19 and 20.
18. Remove four screws (6), stroke control valve (4), and shim(s) (35) from hydraulic pump housing (13).

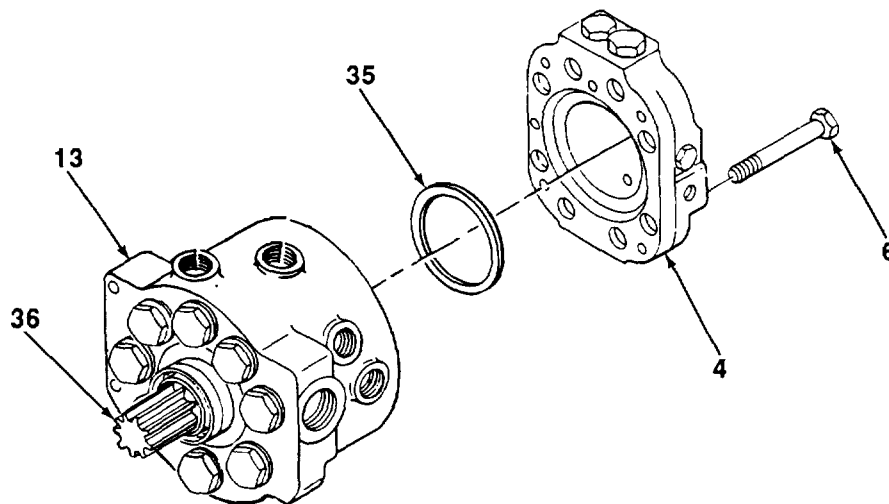

14-3. HYDRAULIC PUMP ASSEMBLY MAINTENANCE (Con't).**NOTE**

Shims are available in two sizes; 0.006 in. (0.152 mm) and 0.010 in. (0.254 mm).
Add or remove shim(s) until end play specification is met.

19. If measurement in step 17 was less than 0.001 in. (0.025 mm) add shim(s) (35) as required. If measurement was more than 0.003 in. (0.076 mm) remove shim(s) as required.
20. Repeat steps 16 through 19 until end play measurement in step 17 is 0.001-0.003 in. (0.025-0.076 mm).
21. Install eight outlet valves (29), springs (30), guides (31), valve stops (32), and new discharge packings (33) in hydraulic pump housing (13).

NOTE

To ensure proper installation of pistons, springs, and plugs, turn shaft until piston being installed is on the low part of shaft.

22. Apply thin coat of hydraulic fluid to eight pistons (11) and springs (10). Install piston and springs in hydraulic pump housing (13).
23. Install eight sheaths (12), new preformed packings (9), and plugs (8). Torque plugs to 100 lb.-ft. (136 N•m).
24. Install new preformed packing (25) on elbow (26) and install elbow in hydraulic pump housing (13).
25. Install new preformed packing (27) on plug (7) and install plug in hydraulic pump housing (13).
26. Install new preformed packing (23) on plug (24) and install plug in hydraulic pump housing (13).
27. Install new preformed packings (14 and 15) in hydraulic pump housing (13).

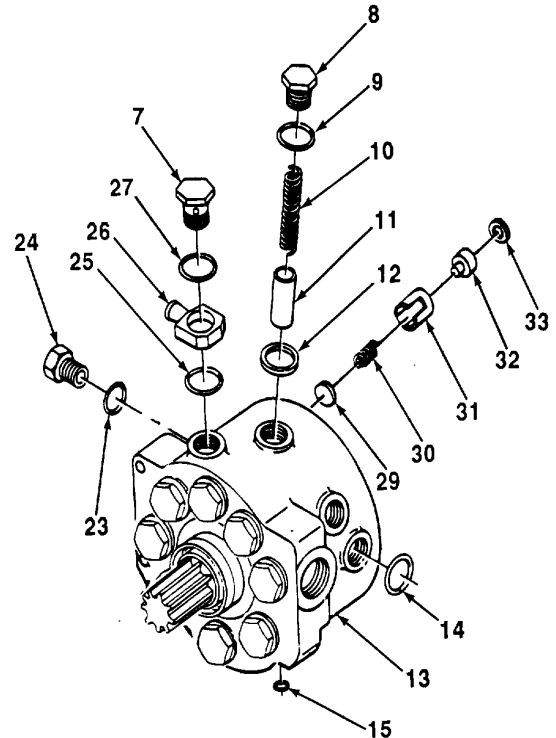
**e. INSTALLATION**

1. Install shim(s) (35) and stroke control valve (4) on hydraulic pump housing (13) with match-marks aligned.
2. Install four screws (6). Torque screws to 85 lb.-ft. (115 N•m).

TA701 556

14-3. HYDRAULIC PUMP ASSEMBLY MAINTENANCE (Con't).

3. Aline hydraulic pump (3) and stroke control valve (4) on bracket (1) and install four screws (5).
4. Tighten two screws 92) on hydraulic pump drive shaft.

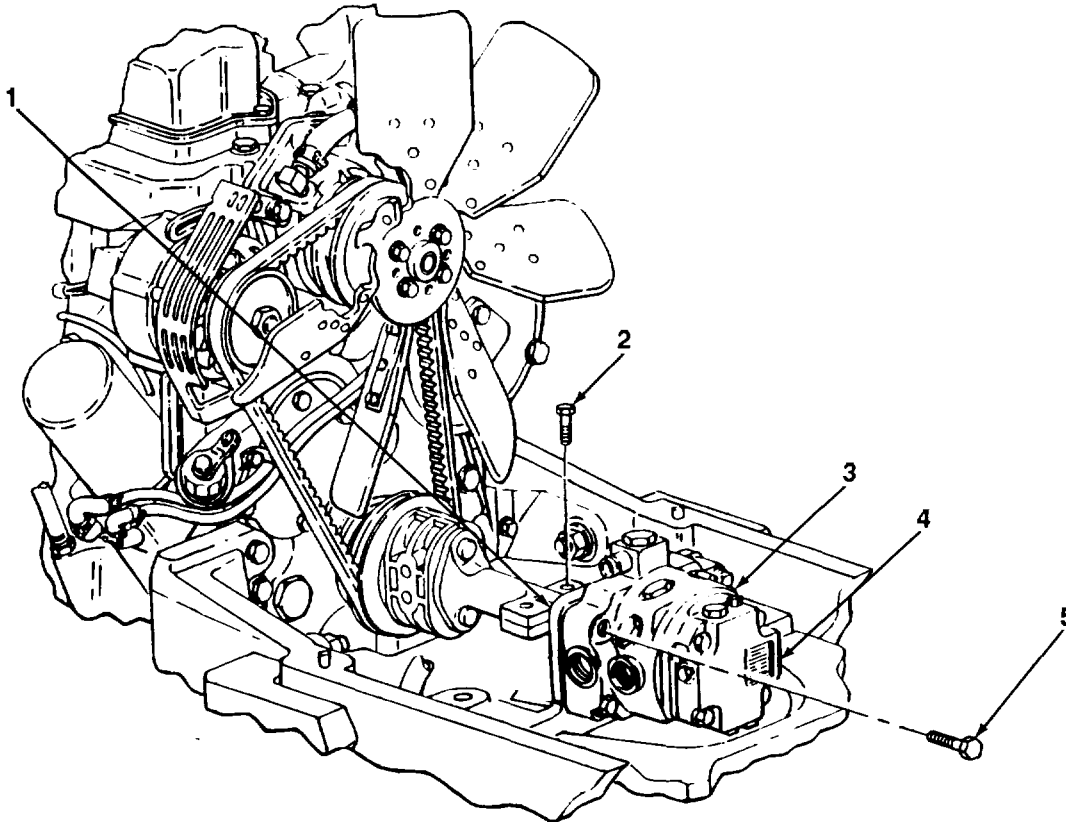
**f. ADJUSTMENT****NOTE**

Use a drain pan to catch fluid when disconnecting oil lines and plugs. Clean up all spills.

1. Install hydraulic pump stroke control valve solenoid (see paragraph 14-7).
2. Connect oil cooler line (see TM 5-2420-222-20).
3. Connect speed gear assembly (reverser) seal drain line (see TM 5-2420-222-20).
4. Connect clutch control valve inlet oil line (see TM 5-2420-222-20).
5. Connect pressure control valve oil line (see TM 5-2420-222-20).
6. Install fuel tank (see TM 5-2420-222-20).
7. Check transmission hydraulic fluid level (see LO 5-2420-222-12).

14-3. HYDRAULIC PUMP ASSEMBLY MAINTENANCE (Con't).

8. Start engine assembly and operate at high idle (see TM 5-2420-222-10).
9. Check hydraulic pump and oil line connections for hydraulic fluid leaks.
10. Shut down engine assembly (see TM 5-2420-222-10).
11. Release hydraulic system pressure (see TM 5-2420-222-20).
12. Remove backhoe valve box (see TM 5-2420-222-20).
13. Disconnect oil line (48) from elbow (49).
14. Install hydraulic system tester to elbow (49).
15. Disconnect oil line (50) from adapter (51). Connect second line of hydraulic system tester to adapter.

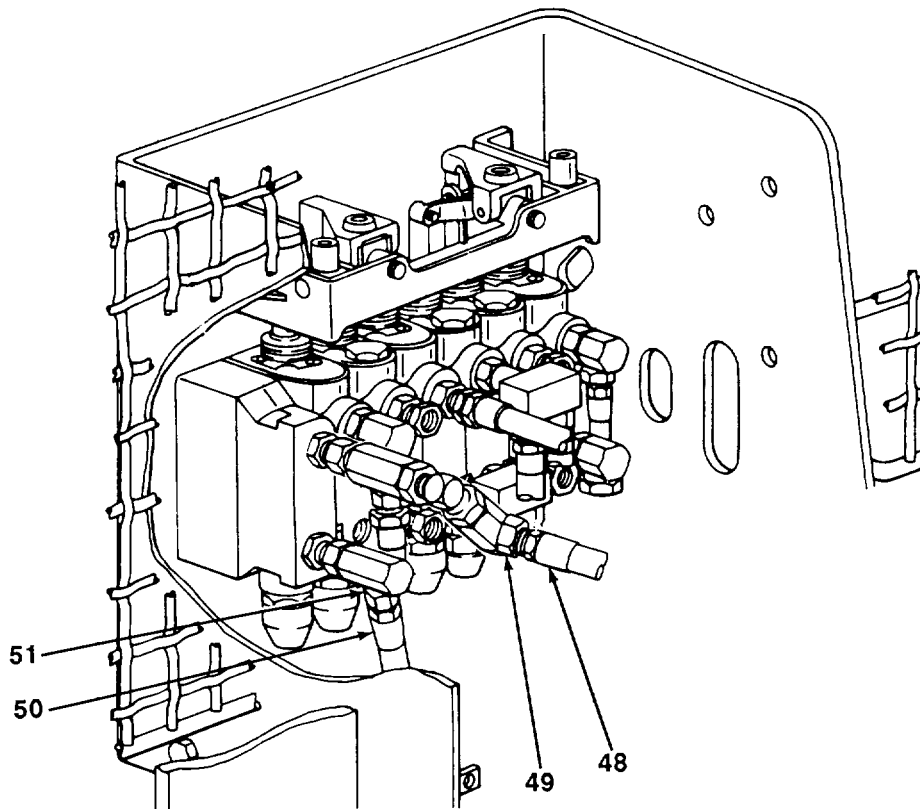

16. Start engine assembly and run at 1500 rpm until operating temperature is 170°F-190°F (77°C-88°C) (see TM 5-2420-222-10).
17. Check for leaks at connections. Tighten connections as required. If leaks stop, proceed to step 21.
18. If leaking does not stop, shut down engine assembly (see TM 5-2420-222-10). Release hydraulic system pressure (see TM 5-2420-222-10). Replace leaking elbow (49) or adapter (51).

TA701558

14-3. HYDRAULIC PUMP ASSEMBLY MAINTENANCE (Con't).

19. Check transmission hydraulic fluid level. Add hydraulic fluid as required (see LO 5-2420-222-12).
20. Repeat steps 16 and 17.
21. Check reading on hydraulic system tester. Pressure must read 2300-2400 psi (15,859-16,548 kPa). If pressure reading is correct, skip step 22.
22. Loosen nut (53) and turn adjusting screw (52) clockwise to increase or counterclockwise to decrease system pressure until reading on hydraulic system tester reads 2300-2400 psi (15,859-16,548 kPa).
23. Adjust engine speed to 1800 rpm (see TM 5-2420-222-10).
24. Adjust hydraulic system tester control valve until pressure gage reads 2000 psi (13,790 kPa). Hydraulic pump flow must be 25 gpm (95 lpm). If pump flow is okay, skip step 25 and go to step 26.
25. Release hydraulic system pressure (see TM 5- 2420-222-20).
26. Remove plug (54) from stroke control valve (4). Remove preformed packing (55) from plug. Discard preformed packing.
27. Connect multirange pressure gage to stroke control valve inlet pressure tap (56).
28. Check transmission hydraulic fluid level (see LO 5-2420-222-12).
29. Start engine assembly and run at 2500 rpm until operating temperature is 170°F-190°F (77°C-88°C) (see TM 5-2420-222-10).
30. Adjust engine speed to 1800 rpm (see TM 5-2420-222-10).
31. Check inlet pressure reading on multirange pressure gage. Pressure reading must be 5 psi (34 kPa). If inlet pressure reading is correct but hydraulic pump flow is below 25 gpm (95 lpm) replace hydraulic pump.
32. Shut down engine assembly (see TM 5-2420-222-10).
33. Release hydraulic system pressure (see TM 5-2420-222-20).
34. Remove multirange pressure gage from stroke control valve inlet pressure tap (56).
35. Install new preformed packing (55) on plug (54) and install plug in stroke control valve (4).

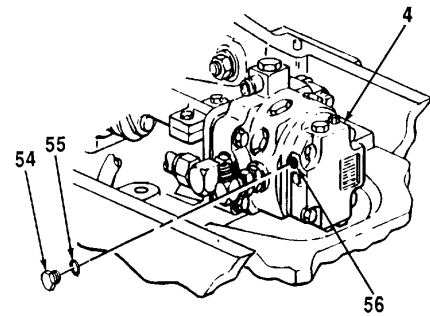
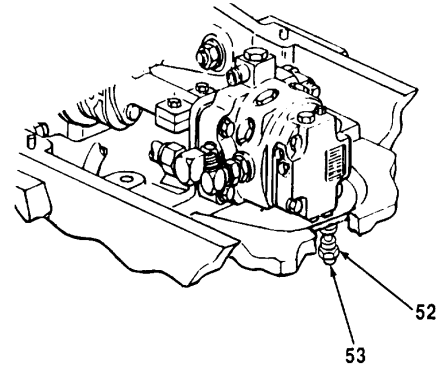

14-3. HYDRAULIC PUMP ASSEMBLY MAINTENANCE (Con't).

36. Disconnect hydraulic system tester from elbow (49) and adapter (51).
37. Connect oil line (50) to adapter (51).
38. Connect oil line (48) to elbow (49).

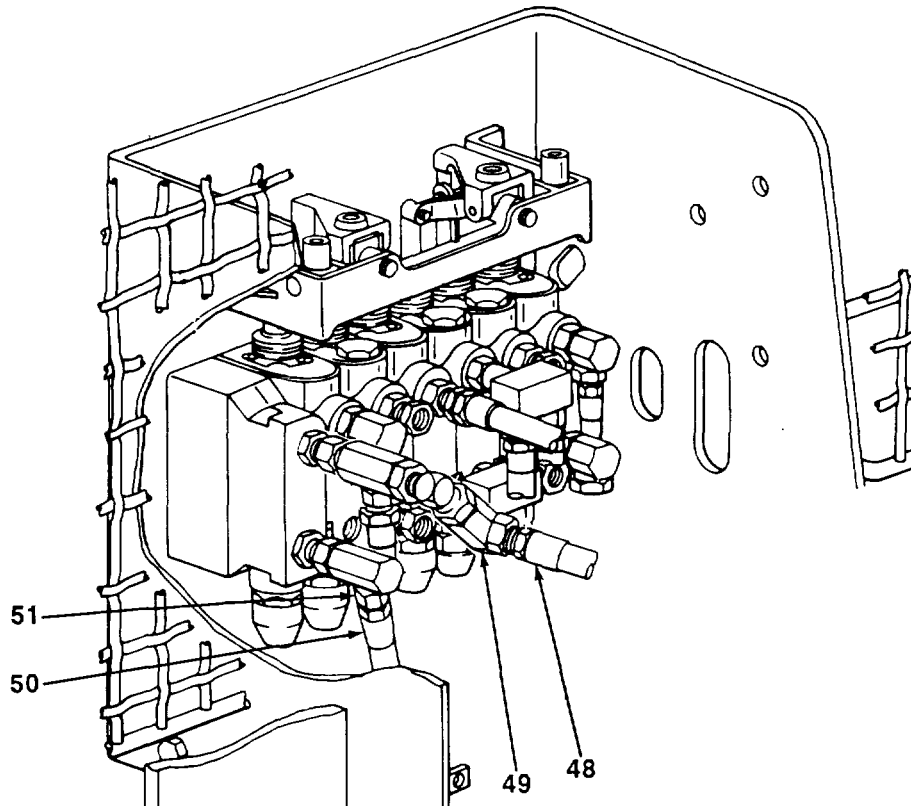
**FOLLOW-ON TASKS:**

- Start engine assembly and check for leaks (see TM 5-2420-222-10).
- Install hood (see TM 5-2420-222-20).

TA701 580

14-4. HYDRAULIC PUMP DRIVE SHAFT AND COUPLER MAINTENANCE (SERIAL NUMBERS 235786-235999).

This Task Covers:

- | | |
|----------------------------|-----------------|
| a. Removal | c. Repair |
| b. Cleaning and Inspection | d. Installation |

Initial Setup:

Equipment Conditions:

- Hood removed (see TM 5-2420-222-20).
- Air cleaner removed (see TM 5-2420-222-20).
- Radiator removed (see TM 5-2420-222-20).

Materials/Parts:

- Thread sealing compound (Item 12, Appendix B)
- Detergent (Item 13, Appendix B)
- Rags (Item 28, Appendix B)
- Dry cleaning solvent (Item 31, Appendix B)
- Two self-locking nuts

Tools/Test Equipment:

- General mechanic's tool kit
- Field automotive shop set

General Safety Instructions:

- Dry cleaning solvent is flammable and must not be used near open flame. Use only in a well-ventilated area.

a. REMOVAL**NOTE**

It may be necessary to use pinch bar to rotate drive shaft to gain access to capscrews.

1. Remove k/ico capscrews (5) from drive shaft (7).
2. Remove two self-locking nuts (4) and capscrews (9) from half couplers (3). Discard self-locking nuts.
3. Remove two half couplers (3) from four rubber bushings (1).
4. Remove four special screws (2) from drive shaft (7) and crankshaft pulley (8). Remove four rubber bushings (1) from special screws.
5. Using pinch bar, remove drive shaft (7) from hydraulic pump (6).

b. CLEANING AND INSPECTION

1. Clean four rubber bushings with water and detergent. Rinse with clean water and dry thoroughly with clean, dry rags.

WARNING

Dry cleaning solvent, P-D-680, is toxic and flammable. Always wear protective goggles and gloves, and use only in a well-ventilated area. Avoid contact with skin, eyes, and clothes, and DO NOT breathe vapors. DO NOT use near open flame or excessive heat. The solvent's flash point is 100°F-138°F (38°C-59°C). If you become dizzy while using cleaning solvent, immediately get fresh air and medical help. If solvent contacts eyes, immediately wash your eyes and get medical aid.

2. Clean all metal parts with dry cleaning solvent and rags. Dry thoroughly with clean, dry rags.

14-4. HYDRAULIC PUMP DRIVE SHAFT AND COUPLER MAINTENANCE (SERIAL NUMBERS 235786-235999) Con't).

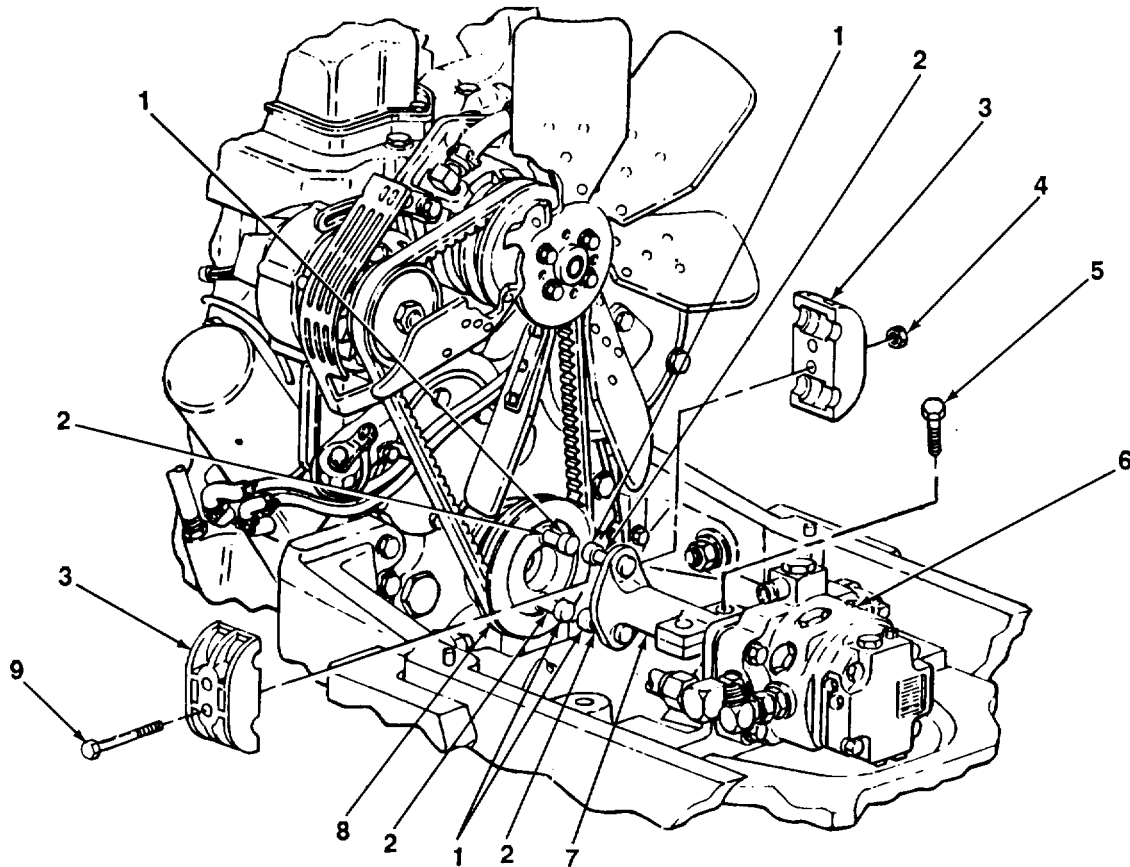

3. Inspect four rubber bushings for cracks, breaks, tears, and excessive wear.
4. Inspect all metal parts for cracks, breaks, and abnormal bends.
5. Inspect drive shaft for damaged threads.

c. REPAIR

Restore damaged drive shaft (7) threads using screw threading set.

d. INSTALLATION

1. Slide drive shaft (7) in place on hydraulic pump (6).

NOTE

Ensure that sealing surfaces are clean before applying thread sealing compound to special screws.

2. Apply 2-3 drops of thread sealing compound to threads of four special screws (2).
3. Install two special screws (2) in drive shaft (7).

TA701561

14-4. HYDRAULIC PUMP DRIVE SHAFT AND COUPLER MAINTENANCE (SERIAL NUMBERS 235786-235999) Con't).

4. Install two special screws (2) in crankshaft pulley (8).
5. Torque four special screws (2) to 32-38 lb.-ft. (43-52 N•m).
6. Install four rubber bushings (1) in place on four special screws (2).
7. Position two half couplers (3) on four rubber bushings (1). Ensure that there is no metal-to-metal contact.
8. Install two capscrews (9) in two half couplers (3) and alternately tighten until snug. Torque capscrews to
9. Install two new self-locking nuts (4) on capscrews (9) and alternately tighten until snug. Torque self-locking nuts to 23-27 lb.-ft. (31-37 N•m).
10. Install two capscrews (5) in drive shaft (7) and alternately tighten until snug. Torque capscrews to 23-27 lb.-ft. (31-37 N•m).

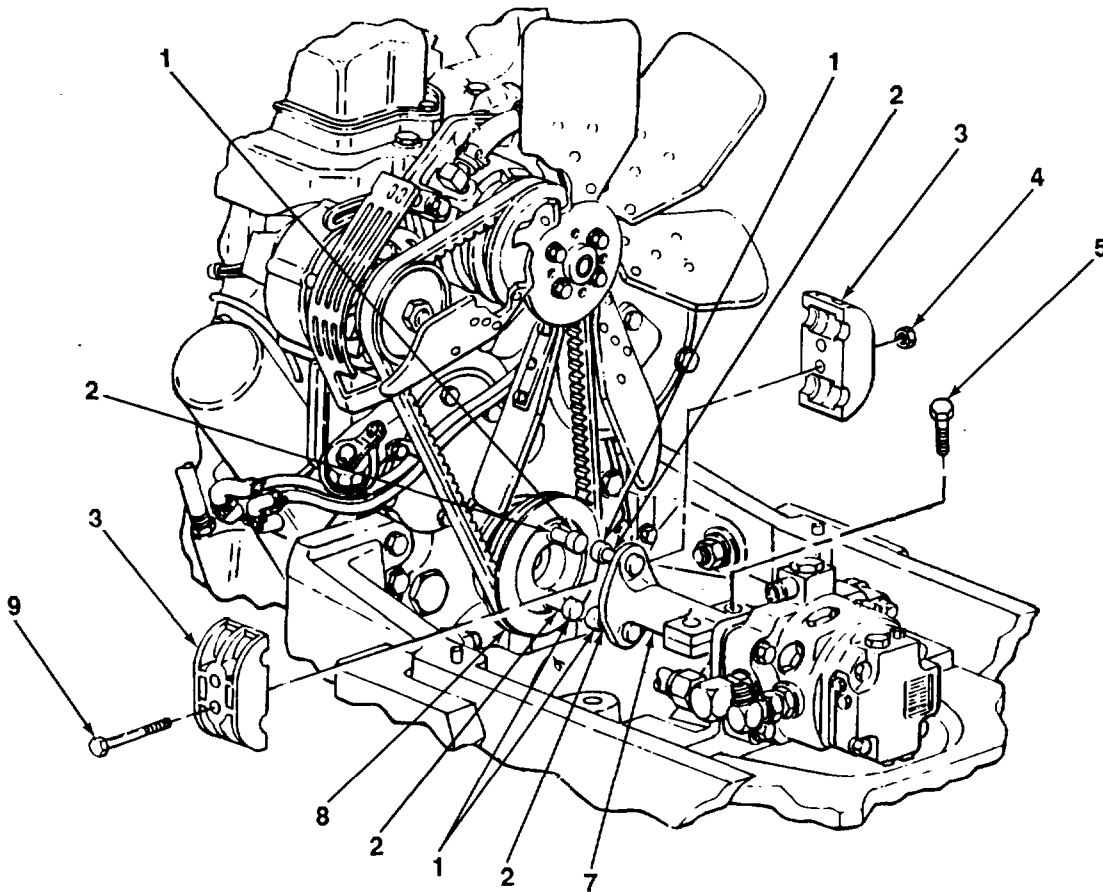

FOLLOW-ON TASKS:

- Install radiator (see TM 5-2420-222-20).
- Install air cleaner (see TM 5-2420-222-20).
- Install hood (see TM 5-2420-222-20).

14-5. HYDRAULIC PUMP DRIVE SHAFT AND COUPLER MAINTENANCE (SERIAL NUMBERS 319995-342573).*This Task Covers:*

- | | |
|----------------------------|-----------------|
| a. Removal | c. Repair |
| b. Cleaning and Inspection | d. Installation |

*Initial Setup:***Equipment Conditions:**

- Hood removed (see TM 5-2420-222-20).
- Air cleaner removed (see TM 5-2420-222-20).
- Radiator removed (see TM 5-2420-222-20).

Tools/Test Equipment:

- General mechanic's tool kit
- Field automotive shop set

Materials/Parts:

- Thread sealing compound (Item 12, Appendix B)
- Detergent (Item 13, Appendix B)
- Rags (Item 28, Appendix B)
- Dry cleaning solvent (Item 31, Appendix B)

General Safety Instructions:

- Dry cleaning solvent is flammable and must not be used near open flame. Use only in a well-ventilated area.

a. REMOVAL**NOTE**

It may be necessary to use pinch bar to rotate drive shaft to gain access to four capscrews.

1. Remove four capscrews 93) from drive shaft (6).

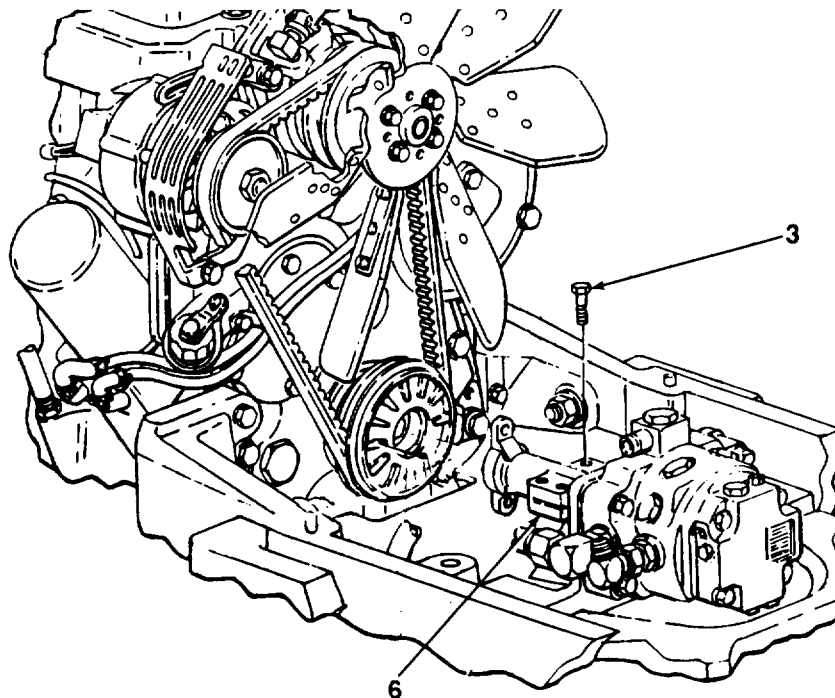

**14-4. HYDRAULIC PUMP DRIVE SHAFT AND COUPLER MAINTENANCE (SERIAL NUMBERS 235786-235999)
Con't).**

2. Remove two capscrews (2) from drive shaft (6) and front coupling half (8).
3. Slide drive shaft (6) and front coupling half (8) forward on hydraulic pump (5).
4. Remove front coupling half (8) and coupling cushion (9) from drive shaft (6) and rear coupling half (1).
5. Remove two special capscrews (4) and rear coupling half (1) from crankshaft pulley (7).
6. Slide drive shaft (6) off hydraulic pump (5).

b. CLEANING AND INSPECTION

1. Clean coupling cushion with water and detergent. Rinse with clean water and dry thoroughly with clean, dry rags.

WARNING

Dry cleaning solvent, P-D-680, is toxic and flammable. Always wear protective goggles and gloves, and use only in a well-ventilated area. Avoid contact with skin, eyes, and clothes, and DO NOT breathe vapors. DO NOT use near open flame or excessive heat. The solvent's flash point is 100°F-138°F (38°C-59°C). If you become dizzy while using cleaning solvent, immediately get fresh air and medical help. If solvent contacts eyes, immediately wash your eyes and get medical aid.

2. Clean all metal parts with dry cleaning solvent and rags. Dry thoroughly with clean, dry rags.
3. Inspect coupling cushion for cracks, breaks, tears, and excessive wear.
4. Inspect all metal parts for cracks, breaks, and abnormal bends.
5. Inspect drive shaft for damaged threads.

c. REPAIR

Restore damaged drive shaft (6) threads using screw threading set.

d. INSTALLATION

1. Slide drive shaft (6) in place on hydraulic pump (5).
2. Position rear coupling half (1) in place on crankshaft pulley (7) and secure with two special capscrews (4). Torque special capscrews to 32-38 lb.-ft. (43-52 N•m).
3. Position coupling cushion (9) in place on rear coupling half (1) with teeth engaged.
4. Position front coupling half (8) in place on coupling cushion (9) with teeth engaged.
5. Slide drive shaft (6) rearward on hydraulic pump (5) until positioned against front coupling half (8).
6. Turn drive shaft (6) until holes in drive shaft align with holes in front coupling half (8).
7. Install two capscrews (2) in drive shaft (6) and front coupling half (8). Torque capscrews to 32-38 lb.-ft. (43-52 N•m).

**14-4. HYDRAULIC PUMP DRIVE SHAFT AND COUPLER MAINTENANCE (SERIAL NUMBERS 319995-342573)
(Con't).**

NOTE

Ensure that sealing surfaces are clean before applying thread sealing compound to capscrews.

8. Apply 2-3 drops of thread sealing compound to threads of four capscrews (3).
9. Install four capscrews (3) in drive shaft (6). Torque capscrews to 32-38 lb.-ft. (43-52 N•m).

FOLLOW-ON TASKS:

- Install radiator (see TM 5-2420-222-20).
- Install air cleaner (see TM 5-2420-222-20).
- Install hood (see TM 5-2420-222-20).

14-6. HYDRAULIC PUMP STROKE CONTROL VALVE REPAIR.*This Task Covers:*

- | | |
|----------------------------|-------------|
| a. Disassembly | c. Assembly |
| b. Cleaning and Inspection | |

*Initial Setup:***Equipment Conditions:**

- Hydraulic pump stroke control valve removed from hydraulic pump (see paragraph 14-3).

Materials/Parts:

- Hydraulic fluid (Item 15, Appendix B)
- Rags (Item 28, Appendix B)
- Dry cleaning solvent (Item 31, Appendix B)
- Two repair kits

Tools/Test Equipment:

- General mechanic's tool kit
- Field automotive shop set
- Two drivers

References:

- TM 5-2420-222-20

General Safety Instructions:

- Dry cleaning solvent is flammable and must not be used near open flame. Use only in a well-ventilated area.

a. DISASSEMBLY

- Remove eight preformed packings (10), preformed packing (9), and preformed packing (11) from control valve body (3). Discard preformed packings.
- Remove preformed packing (8). Discard preformed packing.
- Remove two plugs (2). Remove two preformed packings (1) from plugs. Discard preformed packings.
- Remove drain plug (5). Remove preformed packing (4) from drain plug. Discard preformed packing.
- Remove plug (7). Remove preformed packing (6) from plug. Discard preformed packing.

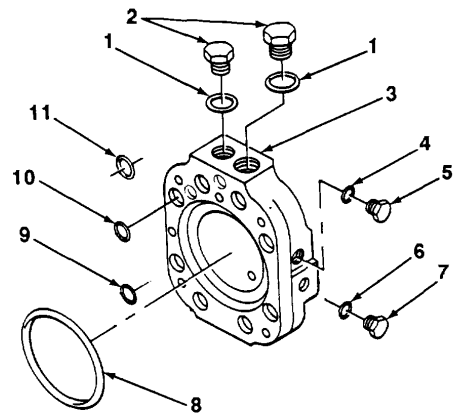

14-6. HYDRAULIC PUMP STROKE CONTROL VALVE REPAIR (Con't).

6. Remove nut (21), screw with washer (20), pre- formed packing (19), and bushing (22) from control valve body (3). Remove preformed pack- ing (23) from bushing. Discard preformed packings.

NOTE

Loader backhoes with serial numbers 235786-235999 are equipped with pins. Loader backhoes with serial numbers 319995-342573 are not.

7. Remove washer (24), washer (25), pin (18), spring (17), seat (16), fluid restrictor (15), preformed packing (14), and sleeve (13) from control valve body (3). Discard preformed packing.
8. Remove preformed packing (12) from control valve body (3). Discard preformed packing.
9. Remove pipe plug (26) from control valve body (3).
10. Remove hydraulic pump stroke control valve filter element (see TM 5-2420-222-20).

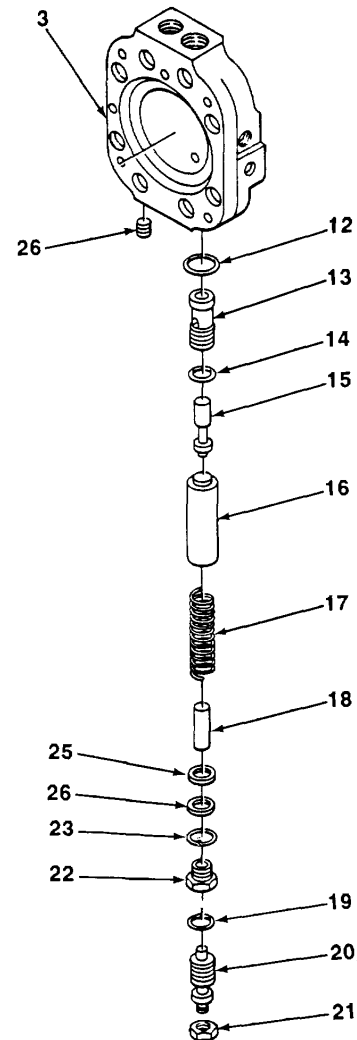

14-6. HYDRAULIC PUMP STROKE CONTROL VALVE REPAIR (Con't).

11. Remove preformed packing (29) and sleeve bushing (28) from control valve body (3). Discard preformed packing.
12. Remove preformed packing (27) from control valve body (3). Discard preformed packing.

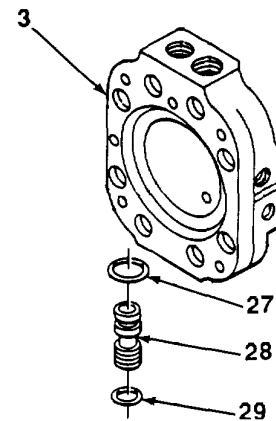
**b. CLEANING AND INSPECTION****WARNING**

Dry cleaning solvent, P-D-680, is toxic and flammable. Always wear protective goggles and gloves, and use only in a well-ventilated area. Avoid contact with skin, eyes, and clothes, and DO NOT breathe vapors. DO NOT use near open flame or excessive heat. The solvent's flash point is 100°F-138°F (38°C-59°C). If you become dizzy while using cleaning solvent, immediately get fresh air and medical help. If solvent contacts eyes, immediately wash your eyes and get medical aid.

1. Clean all metal parts with dry cleaning solvent. Dry thoroughly with clean, dry rags.
2. Inspect control valve body (3) for scoring and excessive wear. Using dial indicator, measure mating surface flatness. Flatness must be within 0.0030 in. (0.0762 mm).
3. Using telescoping gage, measure inside diameter of control valve body bore (30). Measurement must read 0.7485-0.7495 in. (19.0119-19.0373 mm).
4. Using micrometer caliper, measure outside diameter of fluid restrictor (15). Measurement must read 0.2661-0.2665 in. (6.7589-6.7691 mm).
5. Using telescoping gage, measure inside diameter of sleeve (13). Measurement must read 0.3756-0.3762 in. (9.5402-9.5555 mm).
6. Using micrometer caliper, measure outside diameter of sleeve (13). Measurement must read 0.7481-0.7485 in. (19.0017-19.0119 mm).

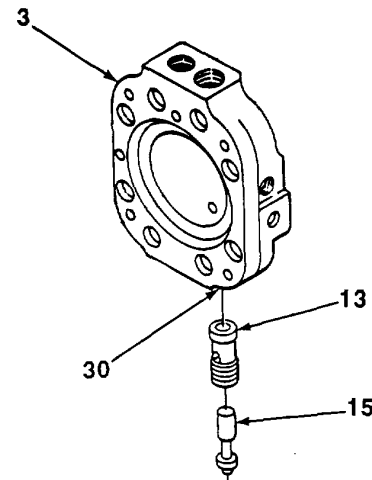

14-6. HYDRAULIC PUMP STROKE CONTROL VALVE REPAIR (Con't).

c. ASSEMBLY

NOTE

Coat all preformed packings with hydraulic fluid as they are assembled.

1. Install new preformed packings (4 and 6) on drain plug (5) and plug (7).
2. Install drain plug (5) and plug (7) in control valve body (3).
3. Install new preformed packing (27) in control valve body (3).
4. Install new preformed packing (29) on sleeve bushing (28). Install sleeve bushing in control valve body (3).
5. Install hydraulic pump stroke control valve filter element (see TM 5-2420-222-20).
6. Install two new preformed packings (1) on two plugs (2). Install plugs in control valve body (3).

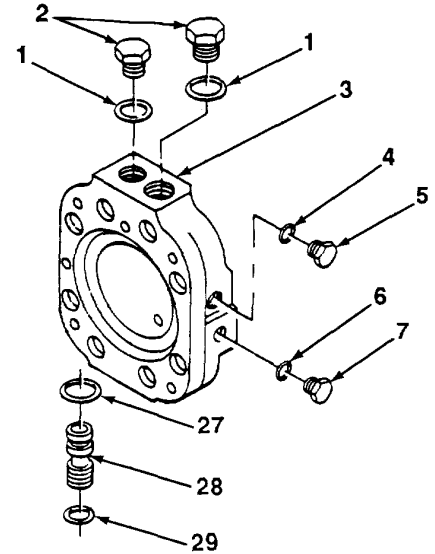

14-6. HYDRAULIC PUMP STROKE CONTROL VALVE REPAIR (Con't).

- 7. Install new preformed packing (12) in control valve body (3).
- 8. Install new preformed packing (14) on sleeve (13). Install sleeve in control valve body (3).
- 9. Install fluid restrictor (15) in control valve body (3).

NOTE

Loader backhoes with serial numbers 235786-235999 are equipped with pins. Loader backhoes with serial numbers 319995- 342573 are not.

- 10. Install seat (16), spring (17), pin (18), washer (25), and washer (24) in control valve body (3).
- 11. Install new preformed packing (23) on bushing (22). Install bushing in control valve body (3).
- 12. Install new preformed packing (19) on screw with washer (20). Install screw with washer and nut (21) in control valve body (3).
- 13. Install pipe plug (26) in control valve body (3).

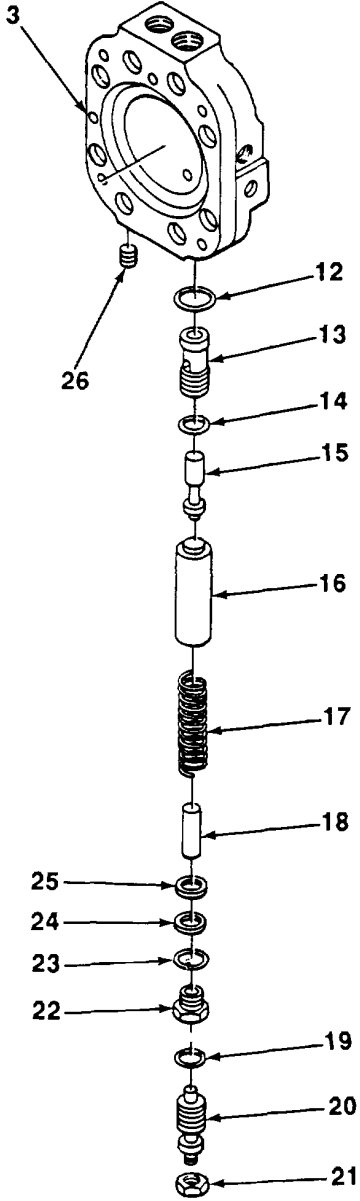

14-6. HYDRAULIC PUMP STROKE CONTROL VALVE REPAIR (Con't).

- 14 Install new preformed packing (9), new preformed packing (11), eight new preformed packings (10), and new preformed packing (8) in control valve body (3).

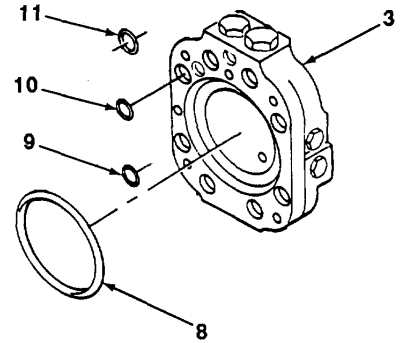
**FOLLOW-ON TASKS:**

- Install hydraulic pump stroke control valve on hydraulic pump assembly (see paragraph 14-3).
- Adjust hydraulic pump assembly (see paragraph 14-3).

TA701 570

14-7. HYDRAULIC PUMP STROKE CONTROL VALVE SOLENOID REPLACEMENT.

This Task Covers:

- a. Removal
- b. Cleaning and Inspection
- c. Installation

Initial Setup:

Equipment Conditions:

- Hydraulic system pressure released (see TM 5-24 222-20).
- Battery ground cable disconnected (see TM 5-24 222-20).
- Left grille removed (see TM 5-2420-222-20).

Materials/Parts:

- Rags (Item 28, Appendix B)
- Trichlorotrifluoroethane (Item 40, Appendix B)
- Two preformed packings

General Safety Instructions:**Tools/Test Equipment:**

- General mechanic's tool kit
- Field automotive shop set

- Trichlorotrifluoroethane cleaning compound is highly flammable and toxic, and must not be used near open flame. Use only in a well-ventilated area.

a. REMOVAL

1. Disconnect wire lead (4) from connector (5).
2. Remove solenoid (3) from hydraulic pump stroke control valve (1).
3. Remove two preformed packings (2) from solenoid (3). Discard preformed packings.

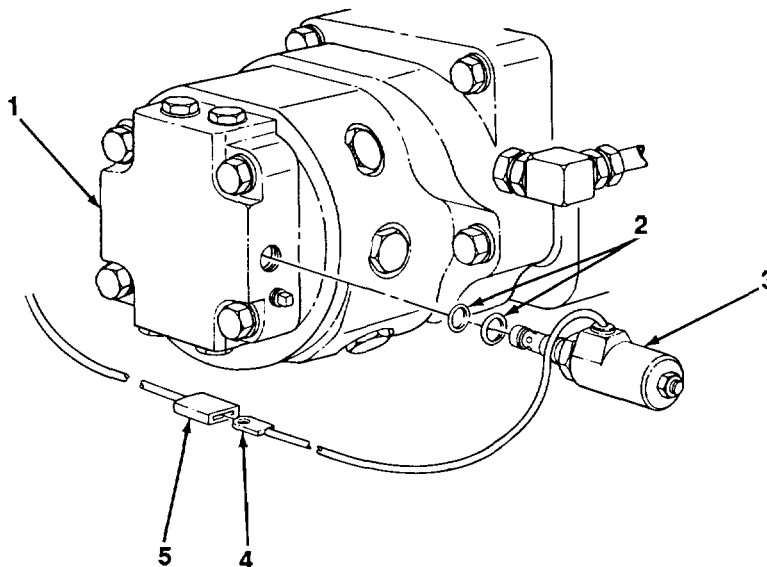

TA701571

14-7. HYDRAULIC PUMP STROKE CONTROL VALVE SOLENOID REPLACEMENT (Con't).

b. CLEANING AND INSPECTION**WARNING**

Cleaning compound, trichlorotrifluoroethane, for electrical parts is toxic and flammable, and reacts violently with aluminum, titanium, barium, lithium, samarium, sodium, and potassium. Always wear protective goggles and rubber gloves, and use only in a well-ventilated area. DO NOT wear jewelry while using cleaning compound. Avoid contact with skin, eyes, and clothes, and DO NOT breathe vapors. Cleaning compound fumes or vapors can take the place of air and may become a cancer producing agent. DO NOT use near open flame or excessive heat. The compound's boiling point is 114°F (46°C). If you become dizzy while using cleaning compound, immediately get fresh air and medical help. If compound contacts eyes, immediately wash your eyes with water and get medical aid.

1. Clean all parts of solenoid with trichlorotrifluoroethane. Wipe dry with a clean, dry rag.
2. Inspect all metal parts for cracks, bends, or breaks.
3. Inspect solenoid cover for cracked, burned, or worn insulation.
4. Inspect for broken wires and loose or corroded terminals.

c. INSTALLATION

1. Install two new preformed packings (2) on solenoid (3).
2. Install solenoid (3) in hydraulic pump stroke control valve (1). Torque solenoid to 20-40 lb.-ft. (27-54 N•m).
3. Connect wire lead (4) to connector (5).

FOLLOW-ON TASKS:

- Connect battery ground cable (see TM 5-2420-222-20).
- Check transmission hydraulic fluid level (see LO 5-2420-222-12).
- Start engine assembly and check for leaks (see TM 5-2420-222-10).
- Install left grille (see TM 5-2420-222-20).

14-8. JAW CONTROL VALVE ASSEMBLY REPAIR.

This Task Covers:

- | | |
|----------------------------|-------------|
| a. Disassembly | c. Repair |
| b. Cleaning and Inspection | d. Assembly |

Equipment Conditions:**NOTE**

Perform the following only for loader backhoes with serial numbers 235786-235999.

- Jaw control valve assembly removed (see TM 5-2420-222-20).

NOTE

Perform the following only for loader backhoes with serial numbers 319995-342573.

- Jaw direct linear valve removed (see TM 5-2420-222-20).

Materials/Parts:

- Hydraulic fluid (Item 15, Appendix B)
- Rags (Item 28, Appendix B)
- Dry cleaning solvent (Item 31, Appendix B)
- Eight preformed packings

Tools/Test Equipment:

- General mechanic's tool kit
- Field automotive shop set

General Safety Instructions

- Dry cleaning solvent is flammable and must not be used near open flame. Use only in a well-ventilated area.

a. DISASSEMBLY

1. Remove two screws (1) and seal retaining plate (2) from valve body (9).
2. Remove two capscrews (15) and valve cap (14) from valve body (9).
3. Hold directional control slide (5) to prevent turning, and remove shouldered screw (16).
4. Remove two spring seats (17) and spring (18) from valve body (9).
5. Remove seal retaining plate (19).
6. Remove directional control slide (5) from other end of valve body (9).
7. Remove two seats (3) and preformed packings (4). Discard preformed packings.
8. Place valve body (9) in vise with caps.
9. Remove plug (10) and preformed packing (11) from valve body (9). Discard preformed packing.
10. Remove main relief (6) with assembled parts and spring (7) from valve body (9).
11. Remove preformed packing (8) from main relief (6). Discard preformed packing.
12. Remove plug (13) and preformed packing (12) from valve body (9). Discard preformed packing.

14-8. JAW CONTROL VALVE ASSEMBLY REPAIR (Con't).

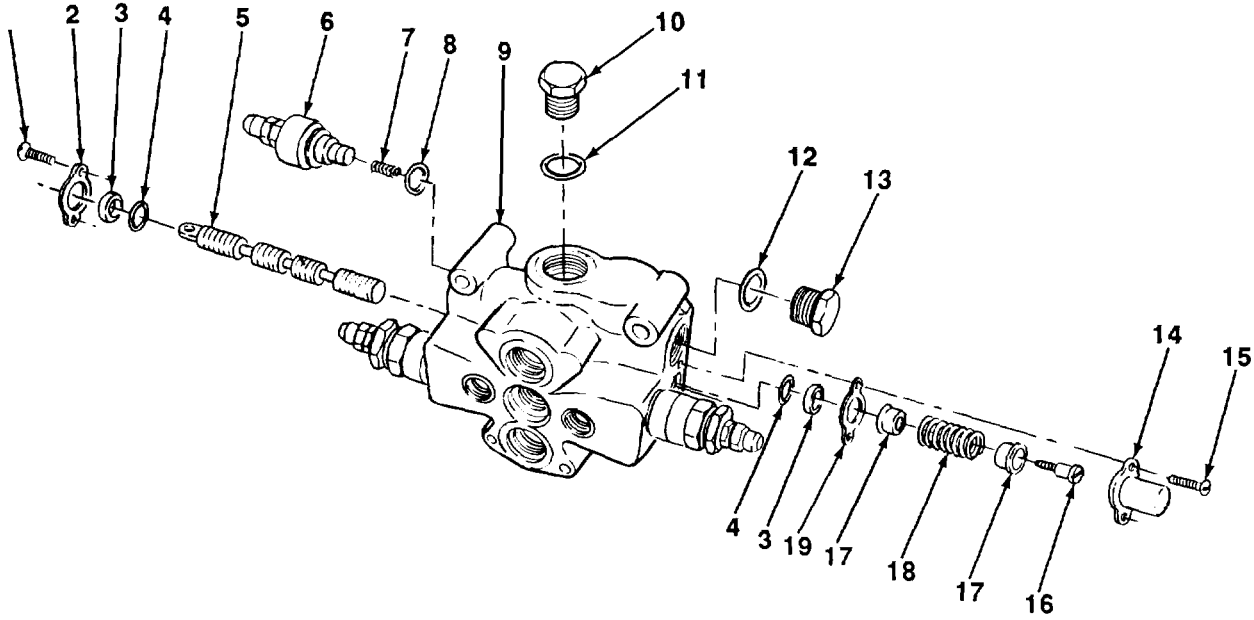

- 13. Remove plug (24), spring (26), and valve disk (27) from valve body (9).
- 14. Remove preformed packing (25) from plug (24). Discard preformed packing.
- 15. Remove pipe plug (23) from valve body (9).
- 16. Remove two cylinder reliefs (20 and 22) with assembled parts from valve body (9).
- 17. Remove two preformed packings (21) from two cylinder reliefs (20 and 22). Discard preformed packings.
- 18. Remove valve body (9) from vise.

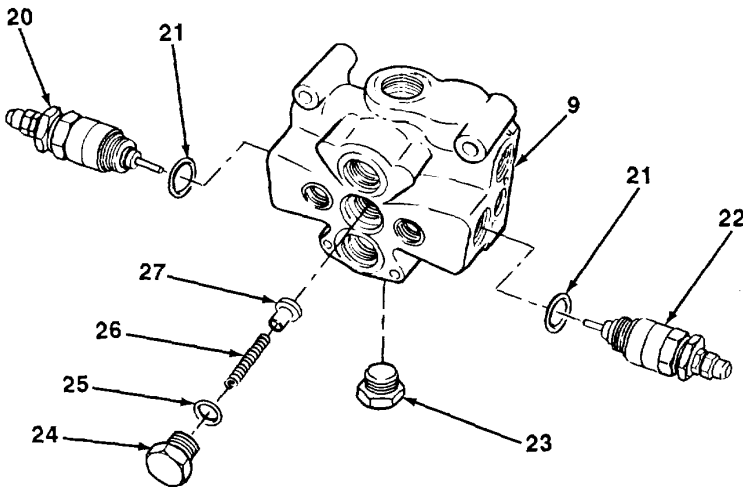

14-8. JAW CONTROL VALVE ASSEMBLY REPAIR (Con't).

b. CLEANING AND INSPECTION**WARNING**

Dry cleaning solvent, P-D-680, is toxic and flammable. Always wear protective goggles and gloves, and use only in a well-ventilated area. Avoid contact with skin, eyes, and clothes, and DO NOT breathe vapors. DO NOT use near open flame or excessive heat. The solvent's flash point is 100°F-138°F (38°C-59°C). If you become dizzy while using cleaning solvent, immediately get fresh air and medical help. If solvent contacts eyes, immediately wash your eyes and get medical aid.

1. Clean cylinder reliefs and main relief with rag dampened in dry cleaning solvent. Dry thoroughly with clean, dry
2. Clean all metal parts with dry cleaning solvent and rags. Dry thoroughly with clean, dry rags.
3. Inspect main relief for damage. If damaged, replace main relief.
4. Inspect two cylinder reliefs for damage. If damaged, replace cylinder relief.
5. Inspect all threaded parts for damaged threads.

c. REPAIR

Restore damaged threads using screw threading set or pipe threading set.

d. ASSEMBLY

1. Soak all Internal valve parts in hydraulic fluid.
2. Place valve body (9) in vise with caps.
3. Install two cylinder reliefs (20 and 22) and new preformed packings (21) in valve body (9).
4. Install pipe plug (23) in valve body (9).
5. Install valve disk (27), spring (26), new preformed packing (25), and plug (24) in valve body (9).

14-8. AW CONTROL VALVE ASSEMBLY REPAIR (Con't)

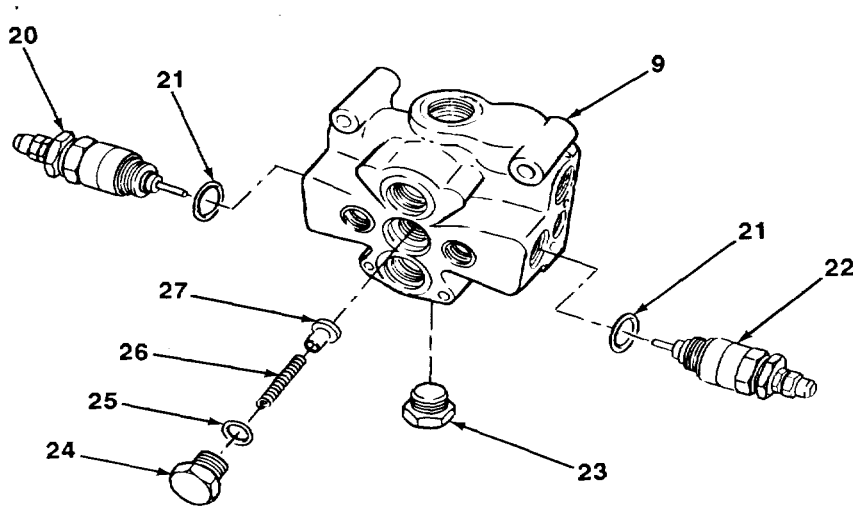

6. Install plug (13) and new preformed packing (12) in valve body (9).
7. Install main relief (6), spring (7), and new pre- formed packing (8) in valve body (9).
8. Install plug (10) and new preformed packing (11) In valve body (9).
9. Remove valve body (9) from vise.

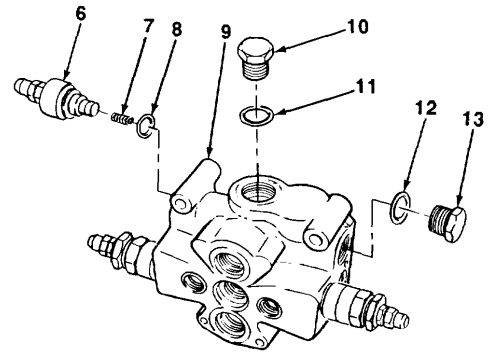

TA701573

14-8. AW CONTROL VALVE ASSEMBLY REPAIR (Con't).

10. Install two seats (3) and new preformed packings (4) on directional control slide (5).
11. Install directional control slide (5) with assembled parts in valve body (9) while holding seats (3) in place.
12. Install seal retaining plate (2) and two screws (1) in valve body (9).
13. Install seal retaining plate (19) on valve body (9).
14. Install two spring seats (17) and spring (18) in place on directional control slide (5) in valve body (9).
15. Hold directional control slide (5) to prevent turning and install shouldered screw (16).
16. Install valve cap (14) on valve body (9) and secure with two capscrews (15).

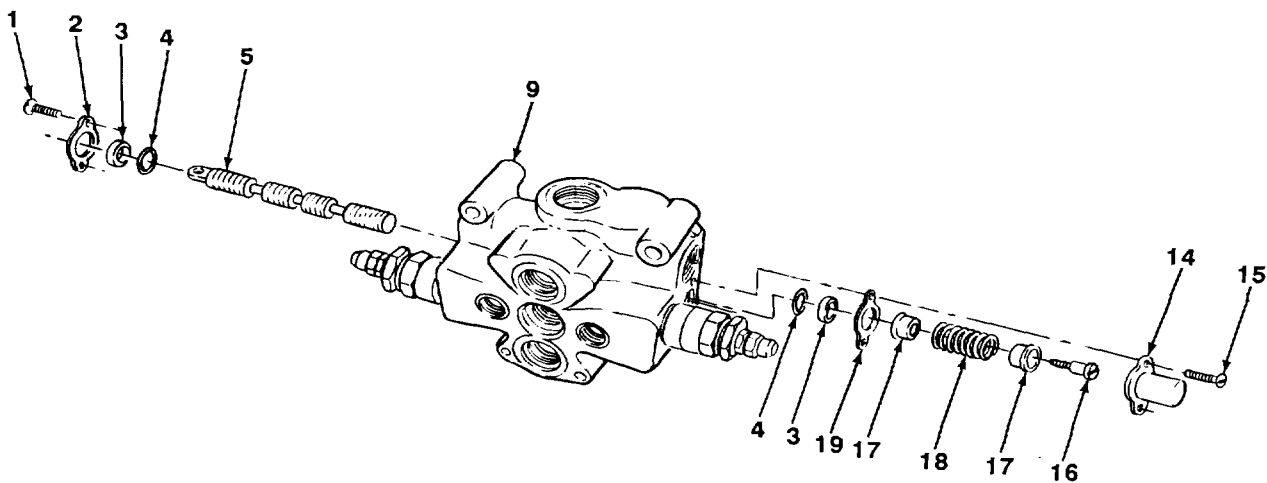

FOLLOW-ON TASKS:

NOTE

Perform the following only for loader backhoes with serial numbers 235786-235999.

- Install jaw control valve assembly (see TM 5-2420-222-20).

NOTE

Perform the following only for loader backhoes with serial numbers 319995-342573.

- Install jaw direct linear valve (see TM 5-2420-222-20).

TA701574

14-9. BACKHOE CONTROL VALVE ASSEMBLY REPAIR.*This Task Covers:*

- | | |
|----------------------------|-------------|
| a. Disassembly | c. Repair |
| b. Cleaning and Inspection | d. Assembly |

Initial Setup.

Equipment Conditions:

- Backhoe control valve assembly removed (see TM 5-2420-222-20)

Tools/Test Equipment:

- General mechanic's tool kit
- Field automotive shop set

Materials/Parts:

- Hydraulic fluid (Item 15, Appendix B)
- Rags (Item 28, Appendix B)
- Dry cleaning solvent (Item 31, Appendix B)
- Five lockwashers
- Twenty-one preformed packings

General Safety Instructions:

- Dry cleaning solvent is flammable and must not be used near open flame. Use only in a well-ventilated area.

a. DISASSEMBLY

1. Using machinist's scribe, match-mark control valve assembly (1) components to ensure proper assembly.

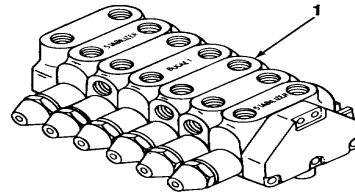

TA701575

14-9. BACKHOE CONTROL VALVE ASSEMBLY REPAIR (Con't).

2. Remove five capscrews (16) and lockwashers (17) from valve head (2) and valve cap (15). Discard lockwashers.
3. Remove valve cap (15), two preformed packings (14), and preformed packing (13) from stabilizer valve (12). Discard preformed packings.
4. Remove valve head (2), two preformed packings (4), and preformed packing (3) from stabilizer valve (5). Discard preformed packings.
5. Remove stabilizer valve (12), two preformed packings (11), and preformed packing (10) from boom valve (9). Discard preformed packings.
6. Remove boom valve (9), two preformed packings (8), and preformed packing (7) from swing valve (6). Discard preformed packings.

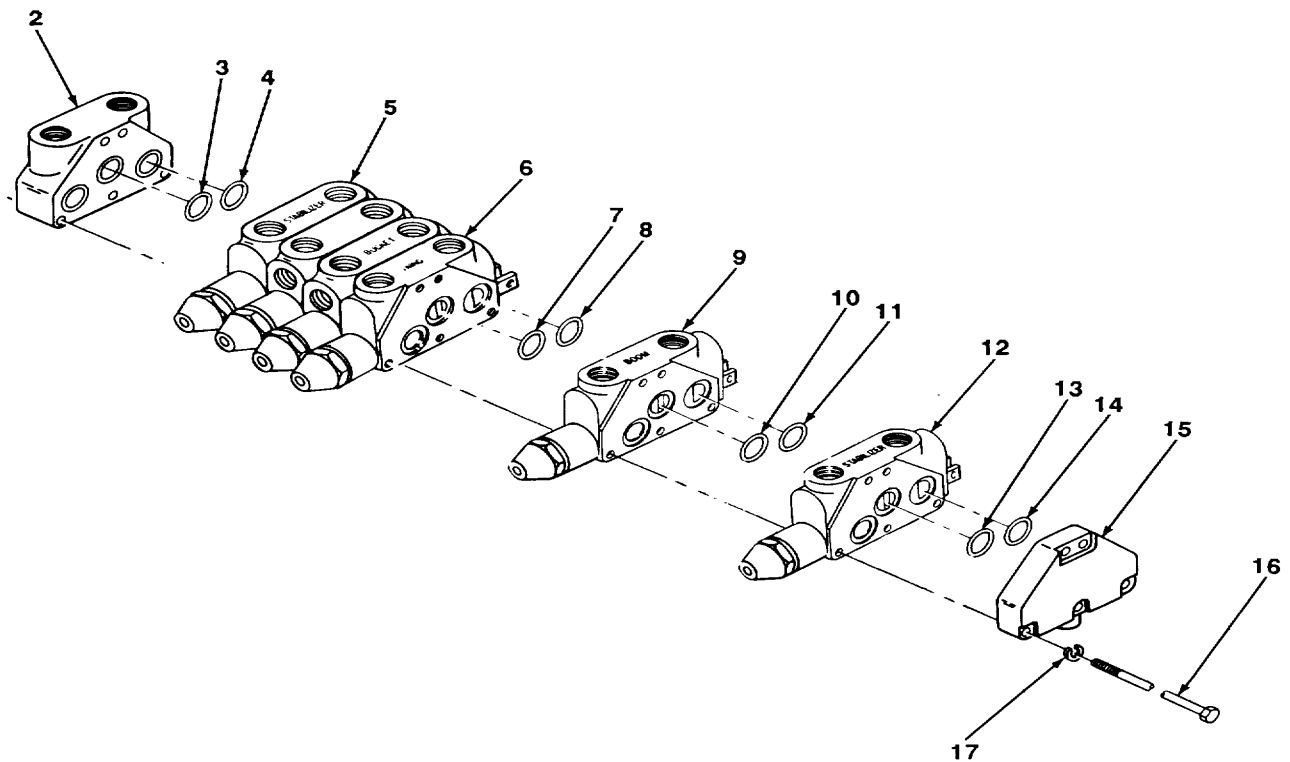

TA701576

14-9. BACKHOE CONTROL VALVE ASSEMBLY REPAIR (Con't).

7. Remove swing valve (6), two preformed packings (23), and preformed packing (22) from bucket valve (24). Discard preformed packings.
8. Remove bucket valve (24), two preformed packings (21), and preformed packing (20) from crowd valve (25). Discard preformed packings.
9. Remove crowd valve (25), two preformed packings (19), and preformed packing (18) from stabilizer valve (5). Discard preformed packings.

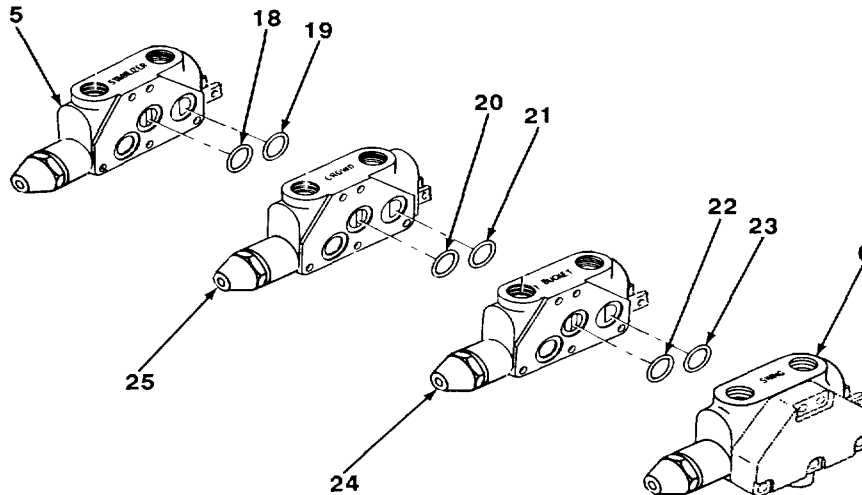
**b. CLEANING AND INSPECTION****WARNING**

Dry cleaning solvent, P-D-680, is toxic and flammable. Always wear protective goggles and gloves, and use only in a well-ventilated area. Avoid contact with skin, eyes, and clothes, and DO NOT breathe vapors. DO NOT use near open flame or excessive heat. The solvent's flash point is 100°F-138°F (38°C-59°C). If you become dizzy while using cleaning solvent, immediately get fresh air and medical help. If solvent contacts eyes, immediately wash your eyes and get medical aid.

1. Clean all metal parts with dry cleaning solvent and rags. Dry thoroughly with clean, dry rags.
2. Inspect all metal parts for cracks, breaks, and abnormal bends.
3. Inspect valve head for damaged threads.

TA701577

14-9. ACKHOE CONTROL VALVE ASSEMBLY REPAIR (Con't).**c. REPAIR**

Restore damaged valve head (2) threads using screw threading or pipe threading set.

d. ASSEMBLY

1. Coat two new preformed packings (4) and new preformed packing (3) with hydraulic fluid and install in valve head (2).
2. Aline match-marks and install stabilizer valve (5) in place on valve head (2).
3. Coat two new preformed packings (19) and new preformed packing (18) with hydraulic fluid and install in stabilizer valve (5).
4. Aline match-marks and install crowd valve (25) on stabilizer valve (5).
5. Coat two new preformed packings (21) and new preformed packing (20) with hydraulic fluid and install in crowd valve (25).

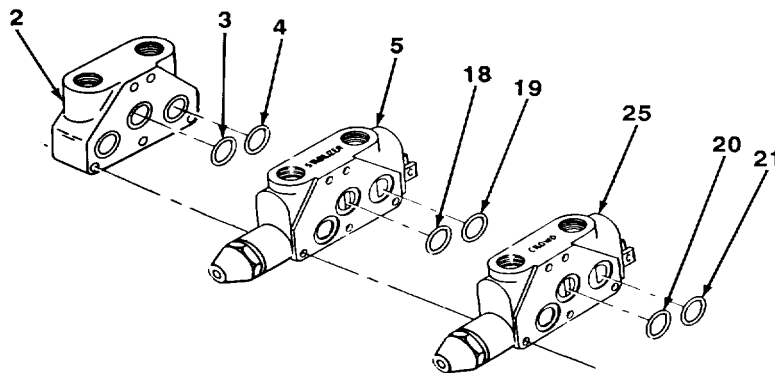

6. Aline match-marks and install bucket valve (24) on crowd valve (25).
7. Coat two new preformed packings (23) and new preformed packing (22) with hydraulic fluid and install in bucket valve (24).
8. Aline match-marks and install swing valve (6) on bucket valve (24).
9. Coat two new preformed packings (8) and new preformed packing (7) with hydraulic fluid and install in swing valve (6).
10. Aline match-marks and install boom valve (9) on swing valve (6).
11. Coat two new preformed packings (11) and new preformed packing (10) with hydraulic fluid and install in boom valve (9).

14-9. BACKHOE CONTROL VALVE ASSEMBLY REPAIR (Con't).

12. Aline match-marks and install stabilizer valve (12) on boom valve (9).
13. Coat two new preformed packings (14) and new preformed packing (13) with hydraulic fluid and install in stabilizer valve (12).

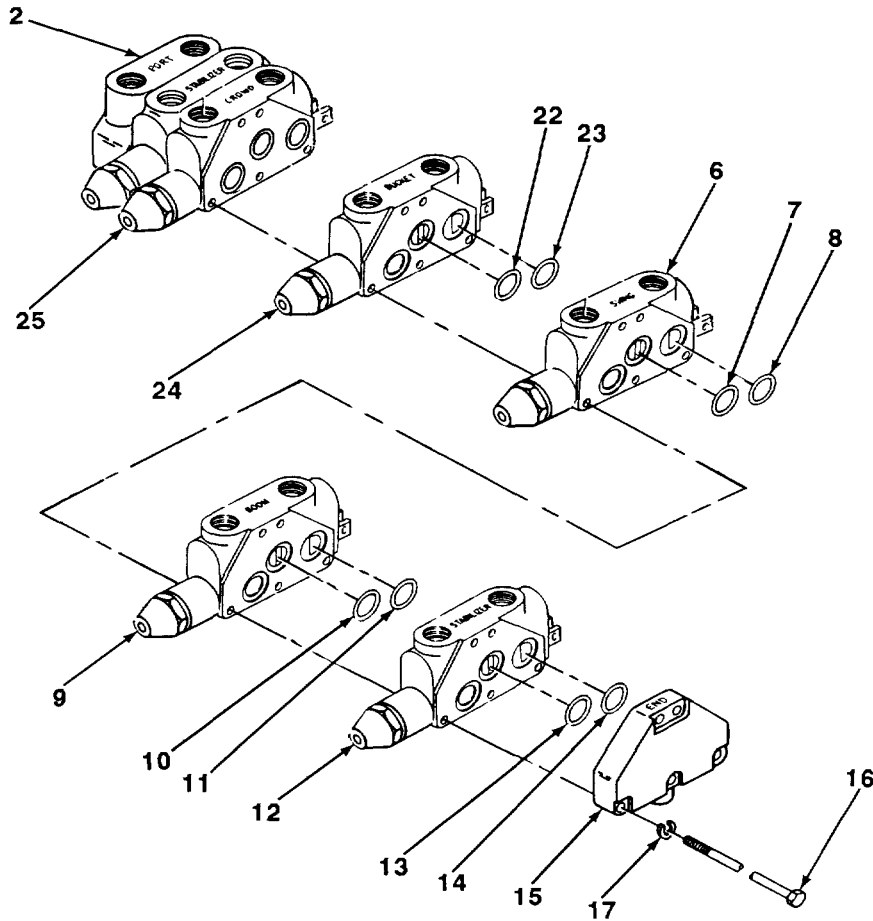

14. Aline match-marks and install valve cap (15) on stabilizer valve (12).
15. Install five capscrews (16) and new lockwashers (17) in valve cap (15) and valve head (2). Torque capscrews to 20-25 lb.-ft. (28-34 N•m).

FOLLOW-ON TASKS:

- Install backhoe control valve assembly (see TM 5-2420-222-20).

TA701579

14-10 BACKHOE STABILIZER AND BUCKET VALVES REPAIR.

This Task Covers:

- | | |
|----------------------------|-------------|
| a. Disassembly | c. Repair |
| b. Cleaning and Inspection | d. Assembly |

Initial Setup:

Equipment Conditions:

- Backhoe control valve assembly disassembled (see) paragraph 14-9)

Tools/Test Equipment:

- General mechanic's tool kit
- Field automotive shop set

Materials/Parts:

- Abrasive cloth (Item 6, Appendix B)
- Thread sealing compound (Item 12, Appendix B)
- Detergent (Item 13, Appendix B)
- Hydraulic fluid (Item 15, Appendix B)
- Rags (Item 28, Appendix B)
- Dry cleaning solvent (Item 31, Appendix B)
- One preformed packing kit

General Safety Instructions:

- Dry cleaning solvent is flammable and must not be used near open flame. Use only in a well-ventilated area.
- Compressed air used for cleaning purposes should never exceed 30 psi (207 kPa).

NOTE

Perform this task to repair both stabilizer valves and bucket valve. One stabilizer valve is shown. Repeat procedure for other valves.

a. DISASSEMBLY

1. Remove two capscrews (6), protective dust cap (5), bellows (4), and washer (3) from valve body (2).
2. Position valve body (2) in vise with caps.

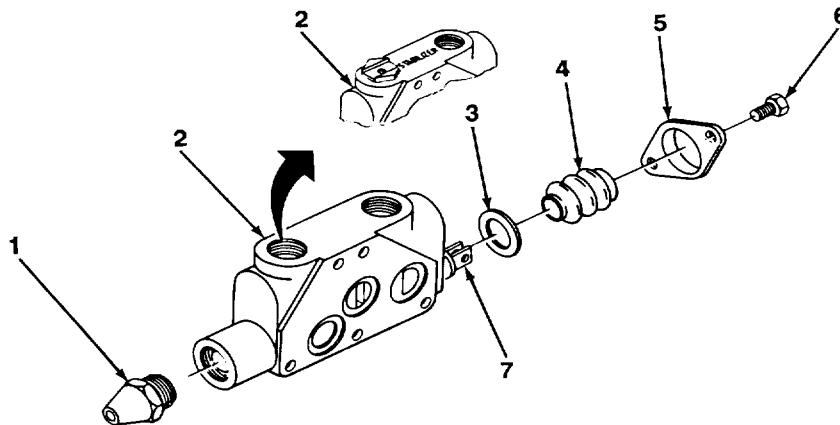

14-10 BACKHOE STABILIZER AND BUCKET VALVES REPAIR (Con't).

4. Hold clevis rod end (7) to prevent turning, and remove bolt (20) from spool plug (13).
5. Remove spool spring (19), spring pin (18), and two washers (17) from valve body (2).
6. Remove valve (12), sleeve bushing (16), and two preformed packings (14 and 15) from valve body (2). Discard preformed packings.

NOTE

Step 7 applies only to stabilizer valves.

7. Remove fluid flow restrictor (8) from valve body (2).
8. Wrap valve (12) in clean rag and place in vise with caps.

NOTE

Ensure that spring and fluid flow restrictor do not fall out when clevis rod end and preformed packing are removed.

9. Remove clevis rod end (7) and preformed packing (9) from valve (12). Discard preformed packing.

NOTE

Step 10 applies only to stabilizer valves.

10. Remove spring (10) and fluid flow restrictor (11) from valve (12).

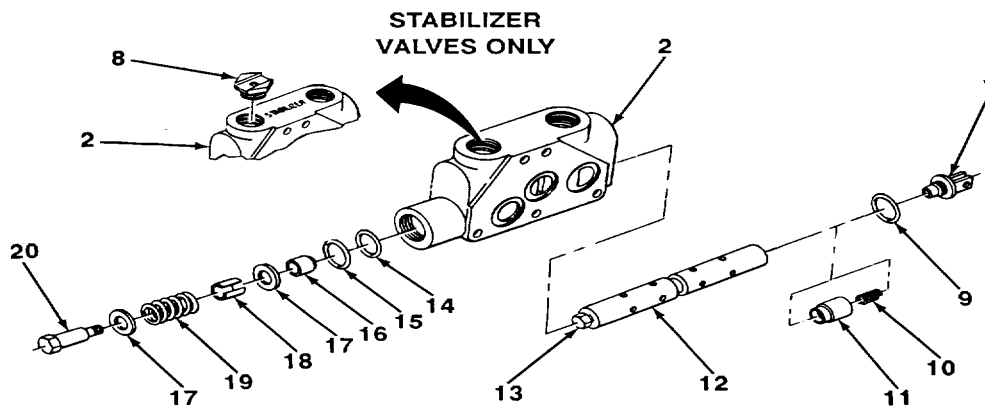

11. Remove spool plug (13), spring (23), preformed packing (21), and fluid flow restrictor (22) from valve (12). Discard preformed packing.

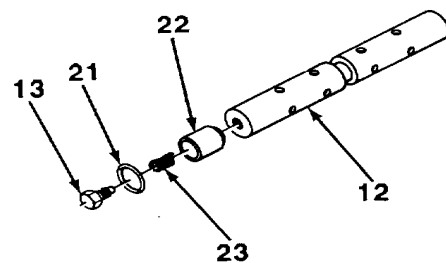

14-10 BACKHOE STABILIZER AND BUCKET VALVES REPAIR (Con't).

b. CLEANING AND INSPECTION

WARNING

- Dry cleaning solvent, P-D-680, is toxic and flammable. Always wear protective goggles and gloves, and use only in a well-ventilated area. Avoid contact with skin, eyes, and clothes, and DO NOT breathe vapors. DO NOT use near open flame or excessive heat. The solvent's flash point is 100°F-138°F (38°C-59°C). If you become dizzy while using cleaning solvent, immediately get fresh air and medical help. If solvent contacts eyes, immediately wash your eyes and get medical aid.
- Compressed air used for cleaning or drying purposes, or for clearing restrictions, should never exceed 30 psi (207 kPa). Wear protective clothing (goggles/shield, gloves, etc.) and use caution to avoid injury to personnel.

1. Clean valve body with rags dampened with dry cleaning solvent. Dry thoroughly with compressed air.
2. Clean three fluid flow restrictors and valve with dry cleaning solvent and rags. Dry thoroughly with compressed air. Ensure that holes are free of material and dirt.
3. Clean all other metal parts with dry cleaning solvent. Dry thoroughly with compressed air.

5. Inspect spool spring (19) for cracks, breaks, and abnormal bends. Using spring tester and torque wrench, apply 27 lb (120 N) of force and measure compressed length of spring. Compressed length must be 1.1875 in. (30.1625 mm).

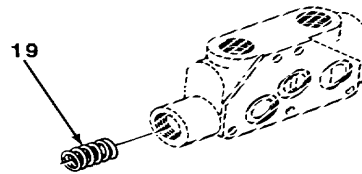

6. Inspect springs (10 and 23) for cracks, breaks, and abnormal bends. Using portable spring resiliency tester and machinist's rule, apply 8 oz (2.2 N) of force and measure compressed length of springs. Compressed length must be 0.8125 in. (20.637 mm).

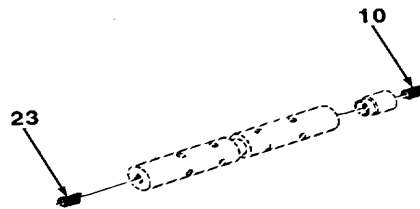

TA701582

14-10. BACKHOE STABILIZER AND BUCKET VALVES REPAIR (Con't).**NOTE**

Valve and valve body are a matched set. If either part is damaged, both must be replaced.

7. Inspect valve for burrs and rough spots.
8. Inspect all other metal parts for cracks, breaks, and abnormal bends. Inspect threaded parts for damaged threads.

c. REPAIR

1. Remove rough spots or burrs from valve (12) using 600 grit abrasive cloth.
2. Restore damaged threads using pipe threading or screw threading set.

d. ASSEMBLY

1. Install fluid flow restrictor (22) in place on spring (23).
2. Coat fluid flow restrictor (22) and spring (23) with hydraulic fluid. Install in place on valve (12).
3. Coat new preformed packing (21) with hydraulic fluid and install in place on spool plug (13).

NOTE

Ensure that sealing surfaces are clean before applying thread sealing compound to spool plug.

4. Apply thread sealing compound to threads of spool plug (13).
5. Wrap valve (12) in clean rags and place in vise with caps.

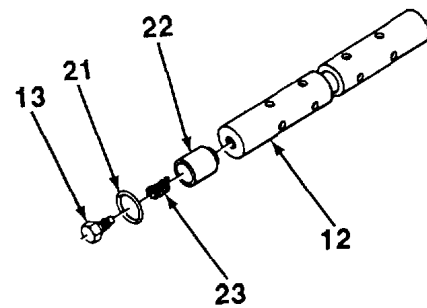

TA701583

14-10. BACKHOE STABILIZER AND BUCKET VALVES REPAIR (Con't).

NOTE

Steps 6 and 7 apply only to stabilizer valves.

6. Install fluid flow restrictor (11) in place on spring (10).
7. Coat fluid flow restrictor (11) and spring (10) with hydraulic fluid, and install in place on valve (12).
8. Coat new preformed packing (9) with hydraulic fluid and install in place on clevis rod end (7).

NOTE

Ensure that sealing surfaces are clean before applying thread sealing compound to clevis rod end.

9. Apply thread sealing compound to threads of clevis rod end (7).
10. Install clevis rod end (7) and assembled part on valve (12). Remove valve from vise.

NOTE

Step 11 applies only to stabilizer valves.

11. Coat fluid flow restrictor (8) with hydraulic fluid and install in valve body (2).

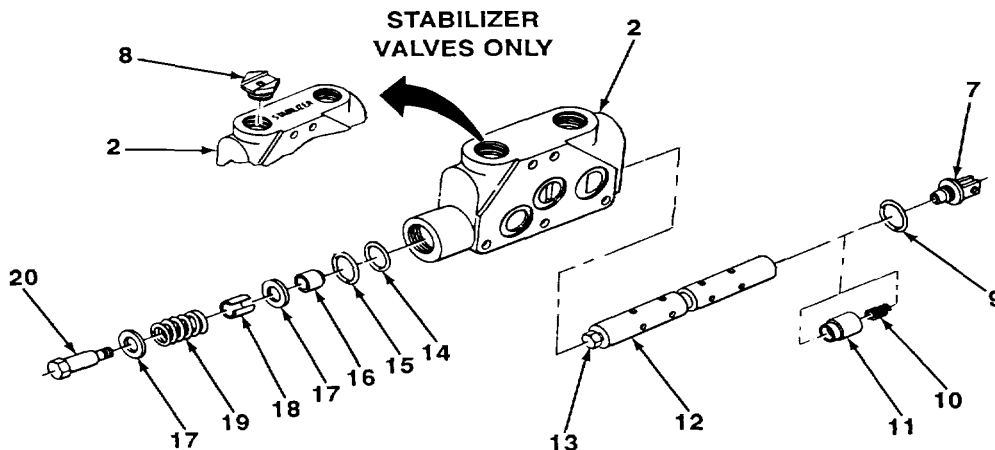

12. Coat two new preformed packings (14 and 15) and sleeve bushing (16) with hydraulic fluid. Install sleeve bushing and new preformed packings in valve body (2).
13. Coat valve (12) with hydraulic fluid and slide into valve body (2).
14. Install spring pin (18) and two washers (17) in valve body (2).
15. Coat spool spring (19) with hydraulic fluid, then install in valve body (2).
16. Hold clevis rod end (7) to prevent turning, and install bolt (20) in spool plug (13). Torque bolt to 5-8 lb.-ft. (7-11 N•m).

14-10 BACKHOE STABILIZER AND BUCKET VALVES REPAIR (Con't).

17. Place valve body (2) in vise with caps. Install valve cap (1) in valve body. Remove valve body from vise.
18. Install washer (3), bellows (4), and protective dust cap (5) over clevis rod end (7) and install with two capscrews (6).

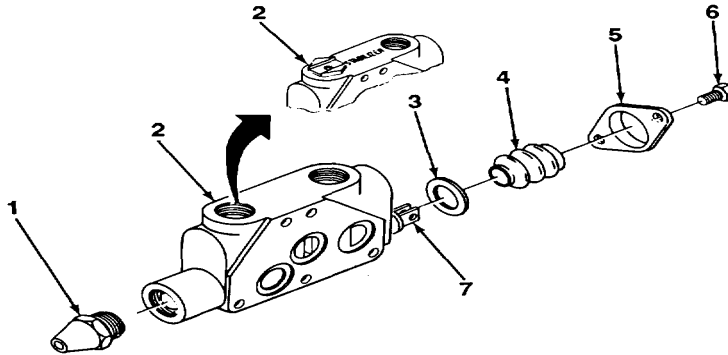
**FOLLOW-ON TASKS:**

- Assemble backhoe control valve assembly (see paragraph 14-9).

TA701 585

14-11. BACKHOE CROWD VALVE REPAIR.

This Task Covers:

- | | | | |
|----|-------------------------|----|----------|
| a. | Disassembly | c. | Repair |
| b. | Cleaning and Inspection | d. | Assembly |

Initial Setup:

Equipment Conditions:

- Backhoe control valve assembly disassembled (see paragraph 14-9).

Tools/Test Equipment:

- General mechanic's tool kit
- Field automotive shop set

Materials/Parts:

- Abrasive cloth (Item 6, Appendix B)
- Thread sealing compound (Item 12, Appendix B)
- Detergent (Item 13, Appendix B)
- Hydraulic fluid (Item 15, Appendix B)
- Dry cleaning solvent (Item 31, Appendix B)
- Rags (Item 28, Appendix B)
- Two repair kits

General Safety Instructions:

- Dry cleaning solvent is flammable and must not be used near open flame. Use only in a well-ventilated area.
- Compressed air used for cleaning purposes should never exceed 30 psi (207 kPa).

a. DISASSEMBLY

1. Remove two capscrews (8), protective dust cap (9), bellows (10), and washer (11) from valve body (17).
2. Position valve body (17) in vise with caps.
3. Remove valve can (11 from valve body (17). Remove valve body from vise.

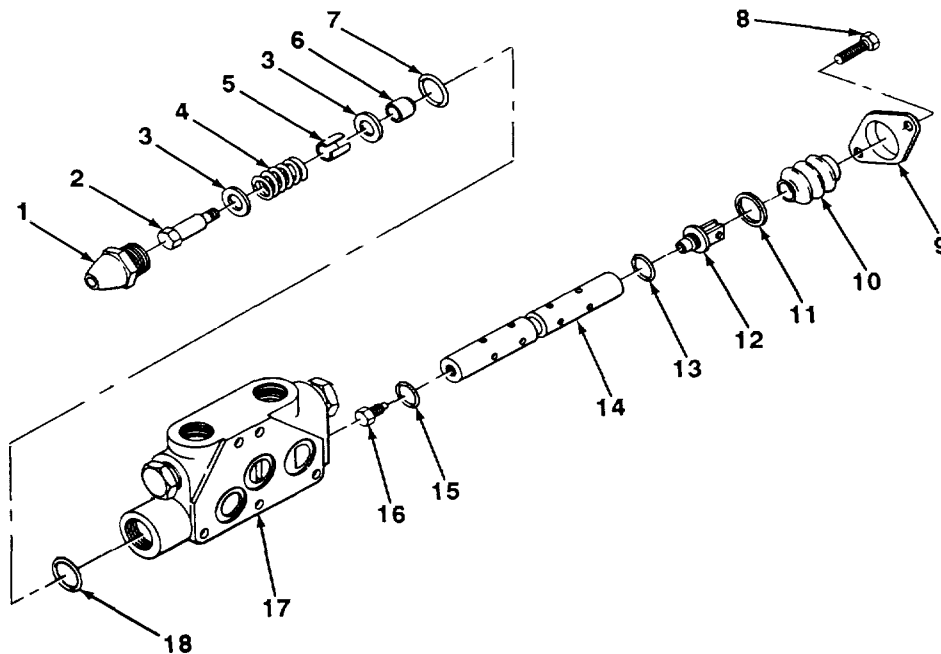

14-11 BACKHOE CROWD VALVE REPAIR (Con't).

4. Hold clevis rod end (12) to prevent turning, and remove bolt (2) from spool plug (16).
5. Remove spool spring (4), spring pin (5), and two washers (3) from valve body (17).
6. Remove valve (14), sleeve bushing (6), and two preformed packings (7 and 18) from valve body (17). Discard preformed packings.
7. Wrap valve (14) in a clean rag and place in vise with caps.
8. Remove clevis rod end (12) and preformed packing (13) from valve (14). Discard preformed packing.
9. Remove spool plug (16) and preformed packing (15) from valve (14). Discard preformed packing.
10. Remove spring (19) and fluid flow restrictor (20) from valve (14).
11. Place valve body (17) in vise with caps. Remove plug (24) and preformed packing (23). Discard preformed packing.
12. Remove relief valve from valve body (17) (see paragraph 14-13).
13. Remove two preformed packings (21) and backup washers (22) from valve body (17). Discard preformed packings and backup washers.

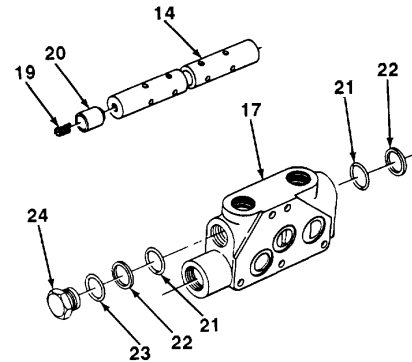
**b. CLEANING AND INSPECTION****WARNING**

- Dry cleaning solvent, P-D-680, is toxic and flammable. Always wear protective goggles and gloves, and use only in a well-ventilated area. Avoid contact with skin, eyes, and clothes, and DO NOT breathe vapors. DO NOT use near open flame or excessive heat. The solvent's flash point is 100°F-138°F (38°C-59°C). If you become dizzy while using cleaning solvent, immediately get fresh air and medical help. If solvent contacts eyes, immediately wash your eyes and get medical aid.
- Compressed air used for cleaning or drying purposes, or for clearing restrictions, should never exceed 30 psi (207 kPa). Wear protective clothing (goggles/shield, gloves, etc.) and use caution to avoid injury to personnel.

1. Clean valve body with rags dampened with dry cleaning solvent. Dry thoroughly with compressed air.
2. Clean fluid flow restrictor and valve with dry cleaning solvent and rags. Dry thoroughly with compressed air. Ensure that holes are free of material and dirt.

TA701 587

14-11. BACKHOE CROWD VALVE REPAIR (Con't).

3. Clean all other metal parts with dry cleaning solvent. Dry thoroughly with compressed air.
4. Clean bellows with rags dampened with water and detergent solution. Rinse with clean water. Dry thoroughly with clean, dry rags.
5. Inspect spool spring (4) for cracks, breaks, and abnormal bends. Using spring tester and torque wrench, apply 27 lb (120 N) of force and measure compressed length of spring. Compressed length must be 1.1875 in.

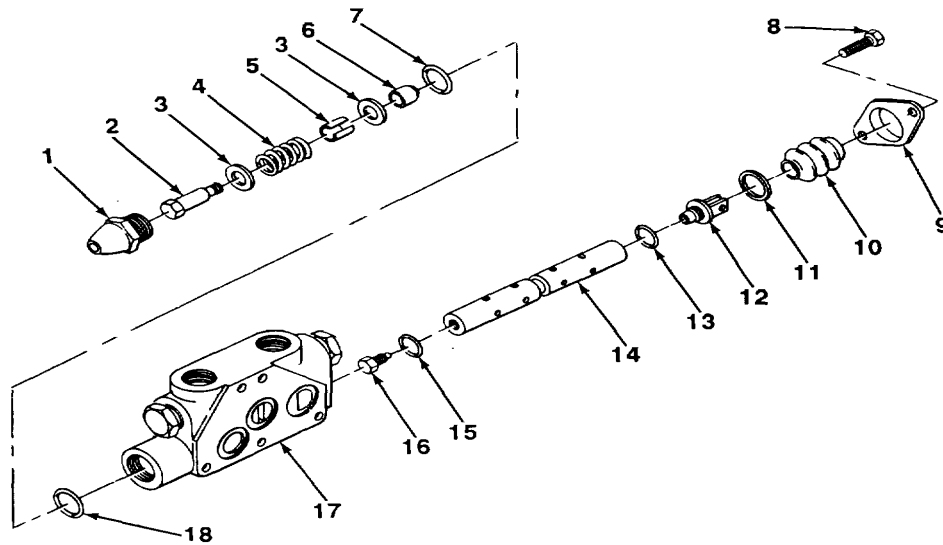

6. Inspect spring (19) for cracks, breaks, and abnormal bends. Using portable spring resiliency tester and machinist's rule, apply 8 oz (2.2 N) of force and measure compressed length of spring. Compressed length must be 0.8125 in. (20.6375 mm).

NOTE

Valve body and valve are a matched set. If either part is damaged, both must be replaced.

7. Inspect valve (14) for burrs and rough spots.
8. Inspect all other metal parts for cracks, breaks, and abnormal bends. Inspect threaded parts for damaged threads.

c. REPAIR

1. Remove rough spots or burrs from valve (14) using 600 grit abrasive cloth.
2. Restore damaged threads using pipe threading or screw threading set.

d ASSEMBLY

1. Coat two new preformed packings (21) and new backup washers (22) with hydraulic fluid.

14-11 BACKHOE CROWD VALVE REPAIR (Con't).

2. Install preformed packings (21) and backup washers (22) in valve body (17).
3. Install relief valve in valve body (17) (see paragraph 14-13).
4. Coat new preformed packing (23) with hydraulic fluid. Install plug (24) and preformed packing in valve body (17).
5. Install fluid flow restrictor (20) in place on spring (19).
6. Coat fluid flow restrictor (20) and spring (19) with hydraulic fluid, then install in place on valve (14).
7. Coat new preformed packing (15) with hydraulic fluid and install in place on spool plug (16).

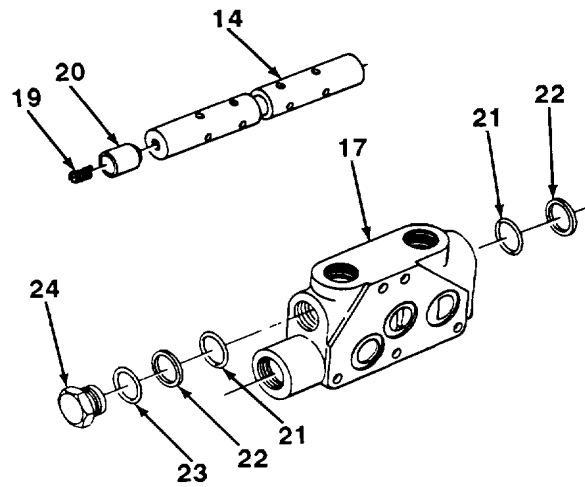

NOTE

Ensure that sealing surfaces are clean before applying thread sealing compound to spool plug.

8. Apply thread sealing compound to threads of spool plug (16).
9. Wrap valve (14) with a clean rag and place in vise with caps. Install spool plug (16) and preformed packing (15) in valve.

NOTE

Ensure that sealing surfaces are clean before applying thread sealing compound to clevis rod end.

10. Coat new preformed packing (13) with hydraulic fluid and install in place on clevis rod end (12).
11. Apply thread sealing compound to threads of clevis rod end (12). Install clevis rod end and assembled parts on valve (14). Remove valve from vise.
12. Coat two new preformed packings (7 and 18) and sleeve bushing (6) with hydraulic fluid. Install sleeve bushing and preformed packings in valve body (17).
13. Coat valve (14) with hydraulic fluid and slide into valve body (17).
14. Install spring pin (5) and two washers (3) in valve body (17).
15. Coat spool spring (4) with hydraulic fluid and install in valve body (17).
16. Hold clevis rod end (12) to prevent turning, and install bolt (2) in spool plug (16). Torque bolt to 5-8 lb.-ft. (7-10 N•m)
17. Place valve body (17) in vise with caps. Install valve cap (1) in valve body. Remove valve body from vise.
18. Install washer (11), bellows (10), and protective dust cap (9) over clevis rod end (12) and secure with two capscrews (8).

FOLLOW-ON TASKS:

- Assemble backhoe control valve assembly (see paragraph 14-9).

14-12 BACKHOE BOOM AND SWING VALVES REPAIR.

This Task Covers:

- | | | | |
|----|-------------------------|----|----------|
| a. | Disassembly | c. | Repair |
| b. | Cleaning and Inspection | d. | Assembly |

Initial Setup:

Equipment Conditions:

- Backhoe control valve assembly disassembled (see paragraph 14-9).

Materials/Parts:

- Abrasive cloth (Item 6, Appendix B)
- Thread sealing compound (Item 12, Appendix B)
- Detergent (Item 13, Appendix B)
- Hydraulic fluid (Item 15, Appendix B)
- Rags (Item 28, Appendix B)
- Dry cleaning solvent (Item 31, Appendix B)

Tools/Test Equipment:

- General mechanic's tool kit
- Field automotive shop set
- Two preformed packing kits

General Safety Instructions:

- Dry cleaning solvent is flammable and must not be used near open flame. Use only in a well-ventilated area.
- Compressed air used for cleaning purposes should never exceed 30 psi (207 kPa).

a. DISASSEMBLY

1. Remove two capscrews (9), protective dust cap (8), bellows (7), and washer (6) from valve body (2).
2. Position valve body (2) in vise with caps.

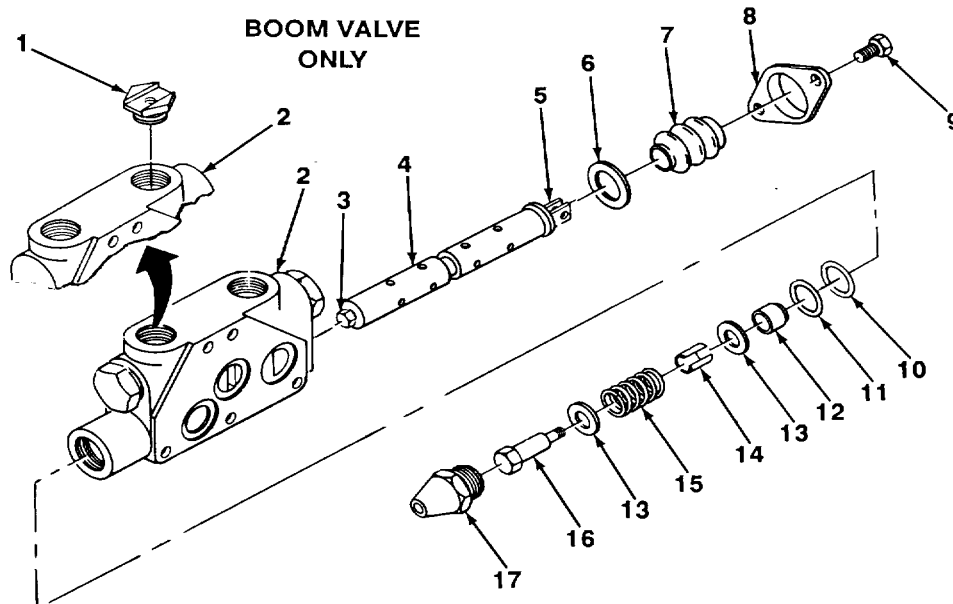

14-12 BACKHOE BOOM AND SWING VALVES REPAIR (Con't).

3. Remove valve cap (17) from valve body (2). Remove valve body from vise.
4. Hold clevis rod end (5) to prevent turning. Remove bolt (16) from spool plug (3).
5. Remove spool spring (15), spring pin (14), and two washers (13) from valve body (2).
6. Remove valve (4), sleeve bushing (12), and two preformed packings (10 and 11) from valve body (2). Discard preformed packings.

NOTE

Step 7 applies only to boom valve.

7. Remove fluid flow restrictor (1) from valve body (2).
8. Wrap valve (4) in a clean rag and place in vise with caps.

NOTE

Ensure that spring and fluid flow restrictor do not fall out when clevis rod end and preformed packing are removed.

9. Remove clevis rod end (5) and preformed packing (20) from valve (4). Discard preformed packing.
10. Remove two springs (19) and fluid flow restrictors (18) from valve (4).
11. Remove spool plug (3) and preformed packing (21) from valve (4). Discard preformed packing.
12. Remove two backhoe boom or swing valve relief valves from valve body (2) (see paragraph 14-13).

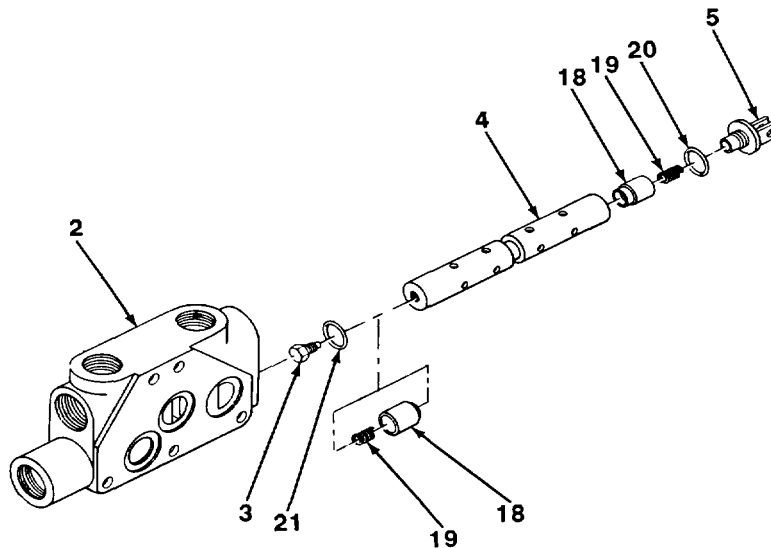

TA701591

14-12. BACKHOE BOOM AND SWING VALVE

13. Remove two preformed packings (23) and backup washers (22) from valve body (2). Discard pre-formed packings and backup washers.

NOTE

Boom valve has only one anti-cavitation detent plunger; swing valve has two. Repeat steps 14 and 15 as required to remove second anti-cavitation detent plunger.

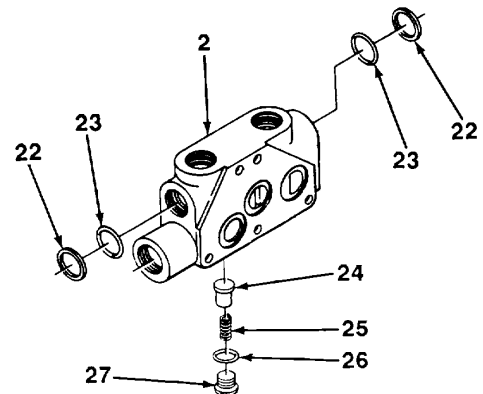

14. Place valve body (2) in vise with caps and remove plug (27) and preformed packing (26). Discard preformed packing.
15. Using magnetic retrieving tool, remove anti-cavitation detent plunger (24) and spring (25) from valve body (2).
16. Remove valve body (2) from vise.

b. CLEANING AND INSPECTION

WARNING

- Dry cleaning solvent, P-D-680, is toxic and flammable. Always wear protective goggles and gloves, and use only in a well-ventilated area. Avoid contact with skin, eyes, and clothes, and DO NOT breathe vapors. DO NOT use near open flame or excessive heat. The solvent's flash point is 100°F-138°F (38°C-59°C). If you become dizzy while using cleaning solvent, immediately get fresh air and medical help. If solvent contacts eyes, immediately wash your eyes and get medical aid.
- Compressed air used for cleaning or drying purposes, or for clearing restrictions, should never exceed 30 psi (207 kPa). Wear protective clothing (goggles/shield, gloves, etc.) and use caution to avoid injury to personnel.

1. Clean valve body with rags dampened with dry cleaning solvent. Dry thoroughly with compressed air.
2. Clean fluid flow restrictor and valve with dry cleaning solvent and rags. Dry thoroughly with compressed air. Ensure that holes are free of material and dirt.
3. Clean all other metal parts with dry cleaning solvent. Dry thoroughly with compressed air.
4. Clean bellows with rags dampened with water and detergent solution. Rinse with clean water. Dry thoroughly with clean, dry rags.
5. Inspect two springs (19) for cracks, breaks, and abnormal bends. Using portable spring resiliency tester and machinist's rule, apply 8 oz (2.2 N) of force and measure compressed length of springs. Compressed length must be 0.8125 in. (20.6375 mm).

14-12. ACKHOE BOOM AND SWING VALVES REPAIR (Con't).

6. Inspect spool spring (15) for cracks, breaks, and abnormal bends. Using spring tester and torque wrench, apply 27 lb (120 N) of force and measure compressed length of spool spring. Compressed length must be 1.1875 in. (30.1625 mm).
7. Inspect spring (25) for cracks, breaks, and abnormal bends. Using spring tester and torque wrench, apply 75 lb (334 N) of force and measure compressed length of spring. Compressed length must be 0.625 in. (15.875 mm).

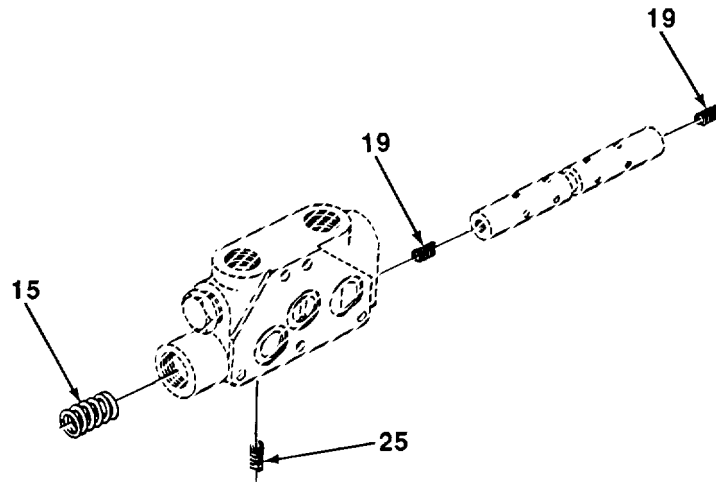

NOTE

Valve body and valve are a matched set. If either part is damaged, both must be replaced.

8. Inspect valve (4) for burrs and rough spots.
9. Inspect all other metal parts for cracks, breaks, and abnormal bends. Inspect threaded parts for damaged threads.

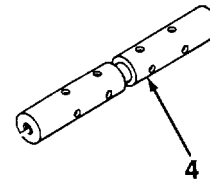

bends.

c. REPAIR

1. Remove rough spots or burrs from valve (4) using 600 grit abrasive cloth.
2. Restore damaged threads using pipe threading or screw threading set.

14-12. ACKHOE BOOM AND SWING VALVES REPAIR (Con't).

d. ASSEMBLY

NOTE

Boom valve has only one anti-cavitation detent plunger; swing valve has two. Repeat steps 1 through 3 as required to remove second anti-cavitation detent plunger.

1. Position spring (25) in detent plunger (24) and coat parts with hydraulic fluid.
2. Place valve body (2) in vise with caps. Install detent plunger (24) and spring (25) in valve body.
3. Coat new preformed packing (26) with hydraulic fluid. Install plug (27) and preformed packing in valve body (2).
4. Remove valve body (2) from vise.
5. Coat two new preformed packings (23) and new backup washers (22) with hydraulic fluid. Install preformed packings and backup washers in valve body (2).
6. Install two backhoe boom or swing valve relief valves from valve body (2) (see paragraph 14-13).
7. Coat new preformed packing (21) with hydraulic fluid and install in place on spool plug (3).

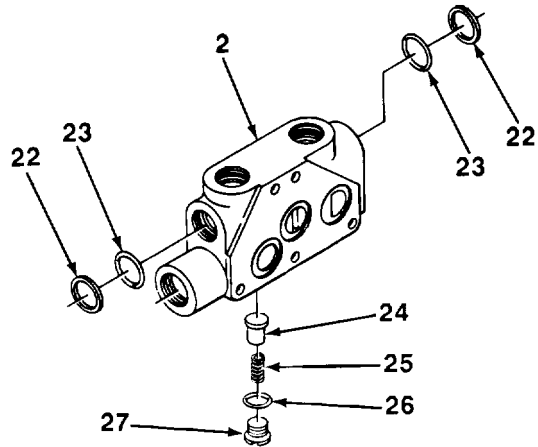

NOTE

Ensure that sealing surfaces are clean before applying thread sealing compound to spool plug.

8. Apply thread sealing compound to threads of spool plug (3).
9. Wrap valve (4) in clean rag and place in vise. Install spool plug (3) and preformed packing (21) in valve.
10. Install two fluid flow restrictors (18) in place on two springs (19).
11. Coat two fluid flow restrictors (18) and two springs (19) with hydraulic fluid and install in place in valve (4).

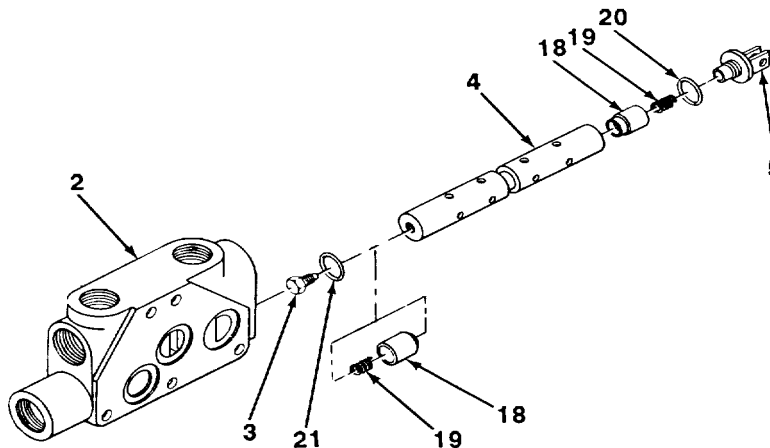

14-12. ACKHOE BOOM AND SWING VALVES REPAIR (Con't).

12. Coat new preformed packing (20) with hydraulic fluid and install in place on clevis rod end (5).

NOTE

Ensure that sealing surfaces are clean before applying thread sealing compound to clevis rod end.

13. Apply thread sealing compound to threads of clevis rod end (5).
 14. Install clevis rod end (5) and assembled parts on valve (4).

NOTE

Step 15 applies only to boom valve.

15. Coat fluid flow restrictor (1) with hydraulic fluid and install in valve body (2).
 16. Coat two new preformed packings (10 and 11) and sleeve bushing (12) with hydraulic fluid. Install sleeve bushing and preformed packings in valve body (2).
 17. Coat valve (4) with hydraulic fluid and slide into valve body (2).
 18. Install spring pin (14) and two washers (13) in valve body (2).
 19. Coat spool spring (15) with hydraulic fluid and install in valve body (2).
 20. Hold clevis rod end (5) to prevent turning. Install bolt (16) in spool plug (3). Torque bolt to 5-8 lb.-ft. (7-11 N•m).
 21. Place valve body (2) in vise with caps. Install valve cap (17) in valve body. Remove valve body from vise.
 22. Install washer (6), bellows (7), and protective dust cap (8) over clevis rod end (5) and secure with two capscrews (9).

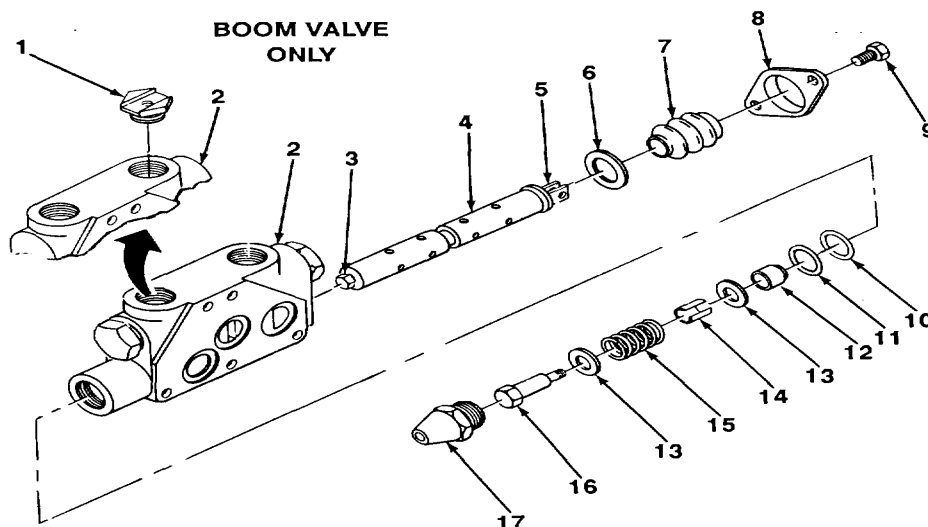
**FOLLOW-ON TASKS:**

- Assemble backhoe control valve assembly (see paragraph 14-9).

TA701595

14-13. BACKHOE RELIEF VALVES MAINTENANCE.*This Task Covers:*

- | | |
|----------------------------|-----------------|
| a. Removal | e. Assembly |
| b. Disassembly | f. Installation |
| c. Cleaning and Inspection | g. Adjustment |
| d. Repair | |

*Initial Setup:***Equipment Conditions:**

- Backhoe control valve assembly removed (see TM 5-2420-222-20).

Tools/Test Equipment:

- General mechanic's tool kit
- Field automotive shop set

References:

- TM 5-2420-222-20

Materials/Parts:

- Hydraulic fluid (Item 15, Appendix B)
- Rags (Item 28, Appendix B)
- Dry cleaning solvent (Item 31, Appendix B)
- One preformed packing kit

General Safety Instructions:

- Dry cleaning solvent is flammable and must not be used near open flame. Use only in a well-ventilated area.
- Compressed air used for cleaning purposes should never exceed 30 psi (207 kPa).

a. REMOVAL**NOTE**

- Relief valves are removed the same way. Swing valve relief valve is shown. Repeat step as required for each relief valve.
- Crowd valve has one relief valve which protects circuit when crowd cylinder is being extended.
- Swing valve has two relief valves which protect circuit when backhoe boom is moved from side to side.
- Boom valve has two relief valves which protect circuit when backhoe boom is raised or lowered.

Remove relief valve (1) with assembled parts and preformed packing (2) from valve body (3). Discard preformed packing.

b. DISASSEMBLY**NOTE**

Relief valves are similar. Only one is shown. Repeat steps 1 through 7 as required.

1. Using retaining ring pliers, remove retaining ring (5) from relief valve (1).
2. Remove valve retainer and ball (4) from relief valve (1).

14-13. BACKHOE RELIEF VALVES MAINTENANCE (Con't).

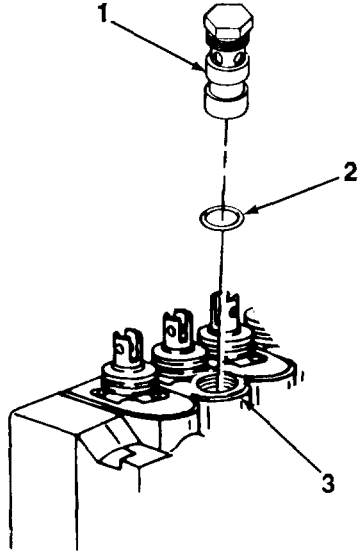
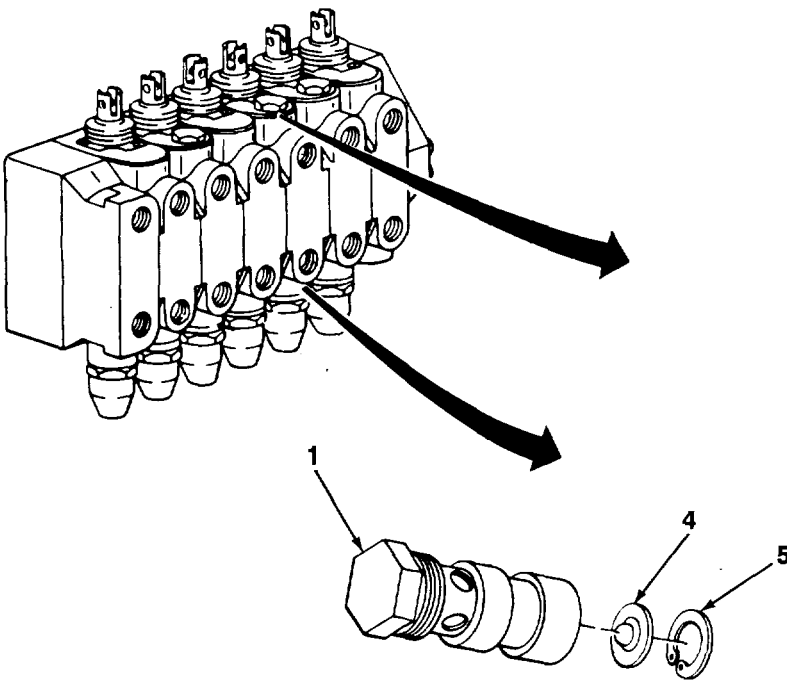

- 3. Place relief valve (1) in vise with caps. Push down on valve seat (10) and compress spring (11).
- 4. Remove bushing (6) and preformed packing (7) from relief valve (1). Discard preformed packing.
- 5. Remove relief valve (1) from vise.
- 6. Remove valve seat (10), preformed packing (8), washer (9), spring (11), and shoulder pin (13) with assembled shims (12) from relief valve (1). Discard preformed packing.

NOTE

Note size and number of shims to ensure proper assembly.

- 7. Remove shims (12) from shoulder pin (13).

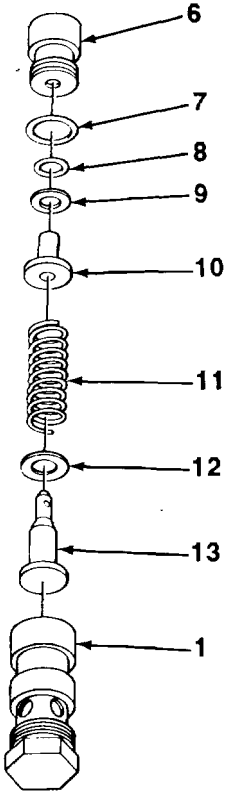

14-13. BACKHOE RELIEF VALVES MAINTENANCE (Con't).

c. CLEANING AND INSPECTION
WARNING

- Dry cleaning solvent, P-D-680, is toxic and flammable. Always wear protective goggles and gloves, and use only in a well-ventilated area. Avoid contact with skin, eyes, and clothes, and DO NOT breathe vapors. DO NOT use near open flame or excessive heat. The solvent's flash point is 100°F-138°F (38°C-59°C). If you become dizzy while using cleaning solvent, immediately get fresh air and medical help. If solvent contacts eyes, immediately wash your eyes and get medical aid.
- Compressed air used for cleaning or drying purposes, or for clearing restrictions, should never exceed 30 psi (207 kPa). Wear protective clothing (goggles/shield, gloves, etc.) and use caution to avoid injury to personnel.

1. Clean all metal parts with dry cleaning solvent. Dry thoroughly with compressed air.
2. Inspect spring for cracks, breaks, and abnormal bends. Using spring tester and torque wrench, apply 122 lb (543 N) of force and measure compressed length of spring. Compressed length must be 1.5 in. (38.1 mm).
3. Inspect all other metal parts for cracks, breaks, and abnormal bends. Inspect threaded parts for damaged

d. REPAIR

Restore damaged threads using screw threading set.

e. ASSEMBLY
NOTE

Relief valves are similar. Only one is shown. Repeat steps 1 through 10 as required.

1. Install proper size and number of shims (12) on shoulder pin (13) as noted during disassembly.
2. Coat shoulder pin (13) and shims (12) with hydraulic fluid and install in relief valve (1).
3. Coat spring (11) with hydraulic fluid and install in relief valve (1).
4. Coat new preformed packing (7) with hydraulic fluid. Install preformed packing on bushing (6).
5. Coat valve seat (10), washer (9), and new preformed packing (8) with hydraulic fluid. Install washer and preformed packing on valve seat.
6. Install valve seat (10) with assembled parts on bushing (6).

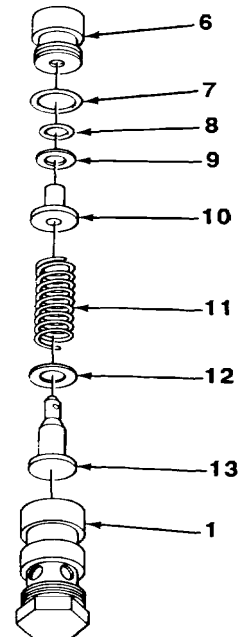

14-13. BACKHOE RELIEF VALVES MAINTENANCE (Con't).

7. Place relief valve (1) in vise with caps. Install bushing (6) and assembled parts in relief valve.
8. Push down on valve seat (10) and compress spring (11). Tighten bushing (6) and assembled parts.
9. Coat valve retainer and ball (4) with hydraulic fluid. Install valve retainer and ball in relief valve (1).
10. Using retaining ring pliers, install retaining ring (5) in relief valve (1). Remove relief valve from vise.

f. INSTALLATION**NOTE**

Relief valves are installed the same way. Swing valve relief valve is shown. Repeat steps 1 and 2 as required for each relief valve.

1. Coat new preformed packing (2) with hydraulic fluid. Install preformed packing on relief valve (1).
2. Install relief valve (1) and preformed packing in valve body (3).

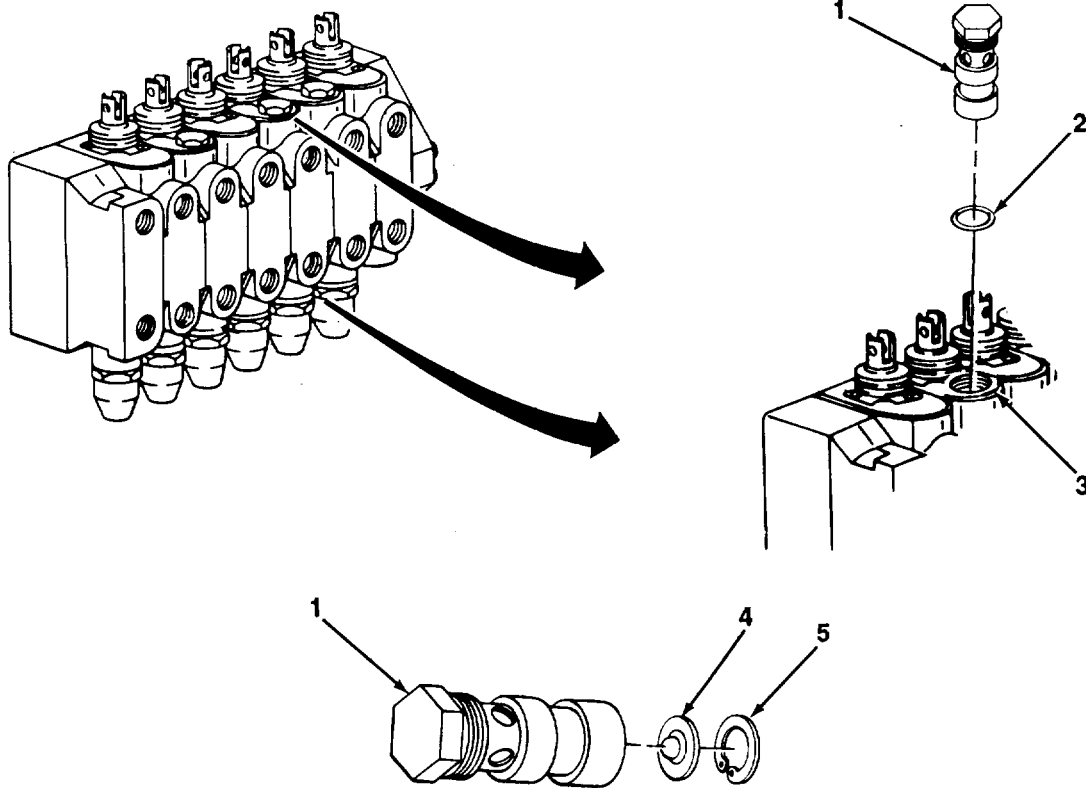

TA701598

14-13. BACKHOE RELIEF VALVES MAINTENANCE (Con't).**g. ADJUSTMENT**

1. If installed, remove backhoe control valve assembly (see TM 5-2420-222-20).
2. Connect proof pressure tester to valve head (21).
3. Using 12 3/4 in. -14 NPT pipe plugs, plug crowd valve (19), bucket valve (18), swing valve (17), boom valve (16), and two stabilizer valves (15 and 20).
4. Using proof pressure tester, pump up hydraulic pressure to 1800 psi (12,411 kPa) and check for leaks. Tighten all leaking connections. If leaking does not stop, replace relief valve (1).

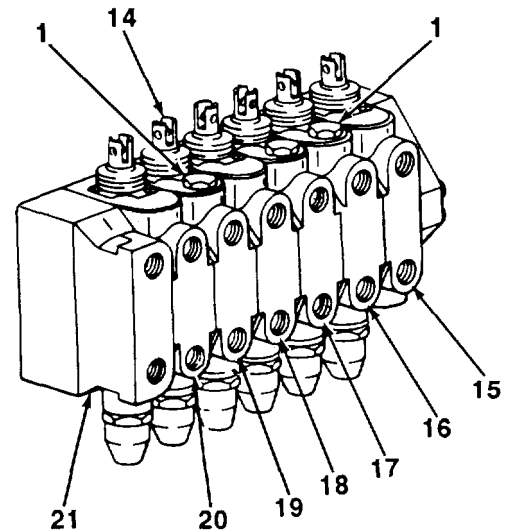
**NOTE**

All relief valves are adjusted the same way. Repeat steps 5 through 9 for each relief valve as required.

5. Push clevis rod end (14) down to check top relief valve (1) or pull up to check bottom relief valve in crowd valve (19), swing valve (17), or boom valve (16).

WARNING

Relief valves are stamped with pressure limit. Crowd, swing, and boom (lower) relief valve pressure limit is 2375 psi (16,376 kPa). Boom (raise) relief valve pressure limit is 3500 psi (24,133 kPa). Do not exceed stamped pressure limit. Serious injury to personnel may result.

6. Using proof pressure tester, pump up hydraulic pressure until relief valve (1) opens or pressure limit of relief valve is reached.

14-13. BACKHOE RELIEF VALVES MAINTENANCE (Con't).

NOTE

If relief valve opening pressure is correct, skip steps 7 through 9.

7. Remove and disassemble relief valve (1) (see subparagraphs a and b).
8. If opening pressure was more than specified, remove shims. If opening pressure was less than specified limit, replace relief valve (1).
9. Assemble, Install, and adjust relief valve (1) (see subparagraphs e, f, and g).

FOLLOW-ON TASKS:

- Install backhoe control valve assembly (see TM 5-2420-222-20).

14-14. LOADER CONTROL VALVE ASSEMBLY REPAIR.*This Task Covers:*

- | | | | |
|----|-------------------------|----|----------|
| a. | Disassembly | c. | Repair |
| b. | Cleaning and Inspection | d. | Assembly |

*Initial Setup:***Equipment Conditions:**

- Loader control valve assembly removed (see TM 5-2420-222-20).

Tools/Test Equipment:

- General mechanic's tool kit

Materials/Parts:

- Detergent (Item 13, Appendix B)
- Hydraulic fluid (Item 15, Appendix B)
- Rags (Item 28, Appendix B)
- Dry cleaning solvent (Item 31, Appendix B)
- Five lockwashers

General Safety Instructions:

- Dry cleaning solvent is flammable and must not be used near open flame. Use only in a well-ventilated area.

a. DISASSEMBLY

1. Using machinist's scribe, match-mark loader control valve assembly parts to ensure proper assembly.
2. Remove five capscrews (1) and lockwashers (2) from two valve caps (3 and 6), boom valve (8), and bucket valve (7). Discard lockwashers.
3. Remove valve cap (3), two preformed packings (4), and preformed packing (5) from boom valve (8). Discard preformed packings.
4. Remove valve cap (6), two preformed packings (4), and preformed packing (5) from bucket valve (7). Discard preformed packings.
5. Remove bucket valve (7), two preformed packings (4), and preformed packing (5) from boom valve (8). Discard preformed packings.

b. CLEANING AND INSPECTION**WARNING**

Dry cleaning solvent, P-D-680, is toxic and flammable. Always wear protective goggles and gloves, and use only in a well-ventilated area. Avoid contact with skin, eyes, and clothes, and DO NOT breathe vapors. DO NOT use near open flame or excessive heat. The solvent's flash point is 100°F-138°F (38°C-59°C). If you become dizzy while using cleaning solvent, immediately get fresh air and medical help. If solvent contacts eyes, immediately wash your eyes and get medical aid.

1. Clean all metal parts with dry cleaning solvent and rags. Dry thoroughly with clean, dry rags.
2. Inspect all metal parts for cracks, breaks, and abnormal bends.
3. Inspect valve caps for damaged threads.

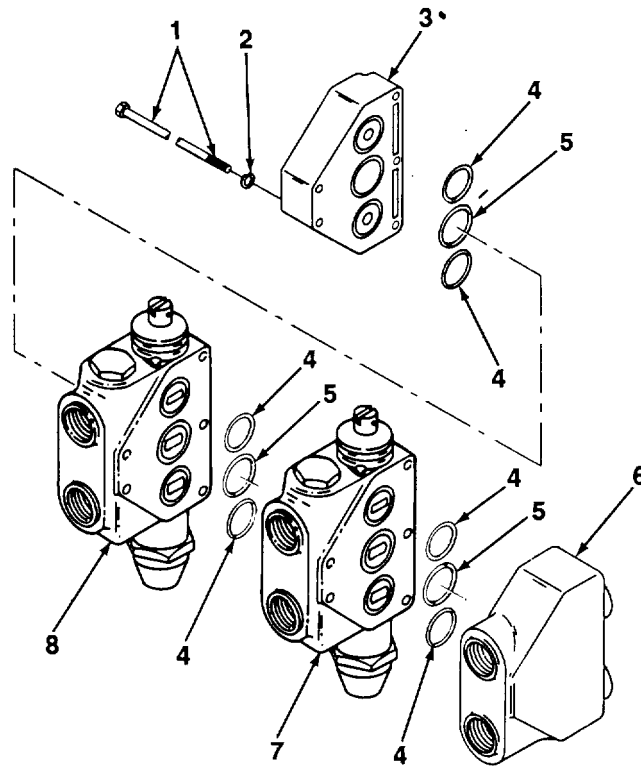
14-13. BACKHOE RELIEF VALVES MAINTENANCE (Con't).**c. REPAIR**

Restore damaged valve cap (3 or 6) threads using pipe threading or screw threading set.

d. ASSEMBLY

1. Coat two new preformed packings (4) and new preformed packing (5) with hydraulic fluid and install in valve cap (3).
2. Aline match-marks and install boom valve (8) in place on valve cap (3).
3. Coat two new preformed packings (4) and new preformed packing (5) with hydraulic fluid and install in boom valve (8).
4. Aline match-marks and install bucket valve (7) on boom valve (8).
5. Coat two new preformed packings (4) and new preformed packing (5) with hydraulic fluid and install in bucket valve (7).
6. Aline match-marks and install valve cap (6) on bucket valve (7).
7. Install five capscrews (1) and new lockwashers (2) in two valve caps (3 and 6), boom valve (8), and bucket valve (7). Torque capscrews to 20-25 lb.-ft. (27-34 N•m).

FOLLOW-ON TASKS:

- Install loader control valve assembly (see TM 5-2420-222-20).

14-15. LOADER BOOM AND BUCKET VALVES REPAIR.*This Task Covers:*

- | | | | |
|----|-------------------------|----|----------|
| a. | Disassembly | c. | Repair |
| b. | Cleaning and Inspection | d. | Assembly |

*Initial Setup:***Equipment Conditions:**

- Loader control valve assembly disassembled (see paragraph 14-14).

Tools/Test Equipment:

- General mechanic's tool kit
- Field automotive shop set

Materials/Parts:

- Abrasive cloth (Item 6, Appendix B)
- Thread sealing compound (Item 12, Appendix B)
- Detergent (Item 13, Appendix B)
- Hydraulic fluid (item 15, Appendix B)
- Rags (Item 28, Appendix B)
- Dry cleaning solvent (Item 31, Appendix B)
- One repair kit

General Safety Instructions:

- Dry cleaning solvent is flammable and must not be used near open flame. Use only in a well-ventilated area.
- Compressed air used for cleaning purposes should never exceed 30 psi (207 kPa).

NOTE

**Perform this task to repair both loader control valves. Boom valve is shown.
Repeat procedure for bucket valve as required.**

a. DISASSEMBLY

1. Remove two screws (3), protective dust cap (4), bellows (2), washer (5), and preformed packing (6) from valve body (32). Discard preformed packing.
2. Position valve body (32) in vise with caps.
3. Remove valve cap (20) from valve body (32). Remove valve body from vise.
4. Hold clevis rod end (23) to prevent turning. Remove spool spring screw (19) from spool plug (14).

NOTE

Perform step 5 only if repairing boom valve. Perform step 6 only if repairing bucket valve.

5. Remove sleeve spacer (18), spring (16), and washer (15) from valve body (32).
6. Remove sleeve spacers (17 and 18), spring (16), and washer (15) from valve body (32).
7. Remove valve (12) with assembled parts, sleeve bushing (22), and preformed packing (21) from valve body (32). Discard preformed packing.
8. Wrap valve (12) in a clean rag and place in vise with caps.
9. Remove clevis rod end (23), spring (25), fluid flow restrictor (11), and preformed packing (24) from valve (12). Discard preformed packing.

14-15. LOADER BOOM AND BUCKET VALVES REPAIR (Con't).

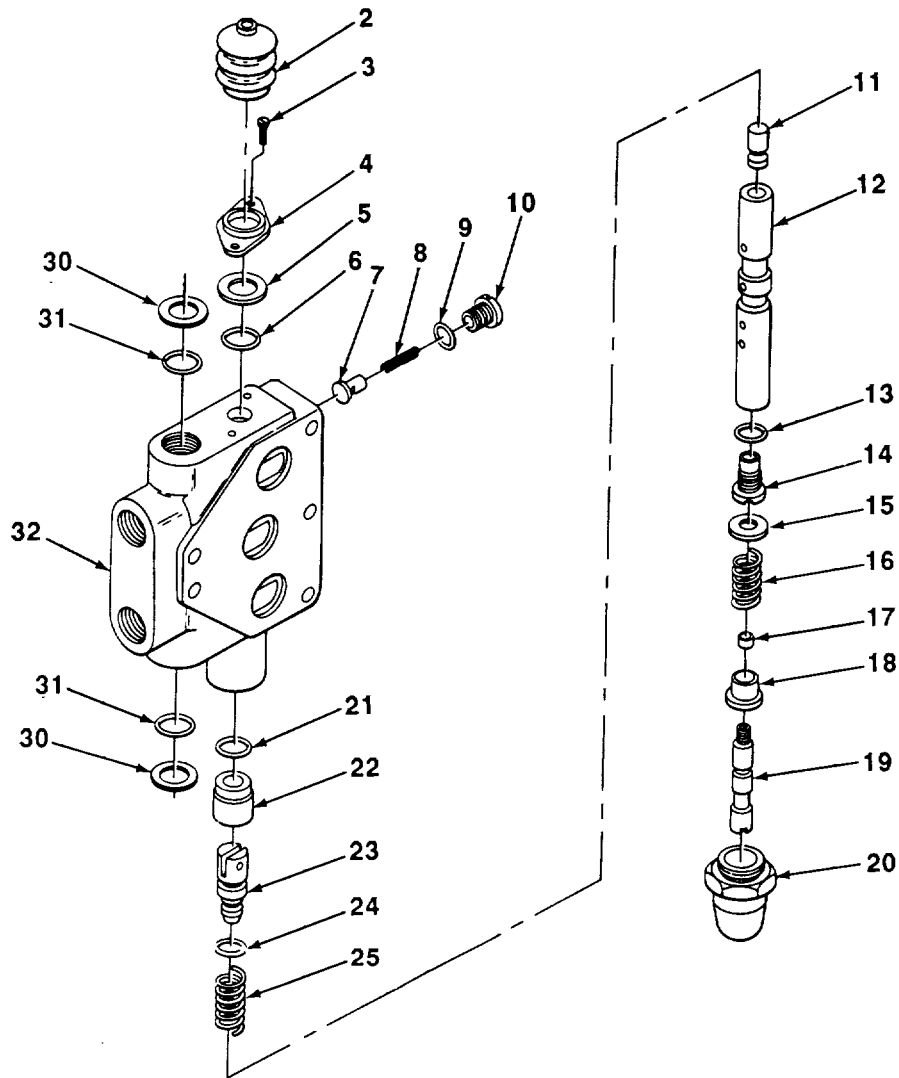

10. Remove spool plug (14) and preformed packing (13) from valve (12). Discard preformed packing.
11. Remove plug (10), preformed packing (9), spring (8), and detent plunger (7) from valve body (32). Discard preformed packing.

NOTE

Perform steps 12 and 13 only if repairing bucket valve.

12. Remove bucket valve relief valves (see paragraph 14-16).
13. Remove two preformed packings (31) and backup washers (30) from valve body (32). Discard preformed packings and backup washers.

TA701601

14-15. LOADER BOOM AND BUCKET VALVES REPAIR (Con't).

NOTE

Perform steps 14 through 16 only if repairing boom valve.

- 14. Remove plug (1), backup washer (30), and two preformed packings (31 and 33). Discard backup washer and preformed packings.
- 15. Remove plug valve (26), backup washer (30), and two preformed packings (28 and 31) from valve body (32). Discard backup washer and preformed packings.
- 16. Remove spring pin (27) and ball bearing (29) from plug valve (26).

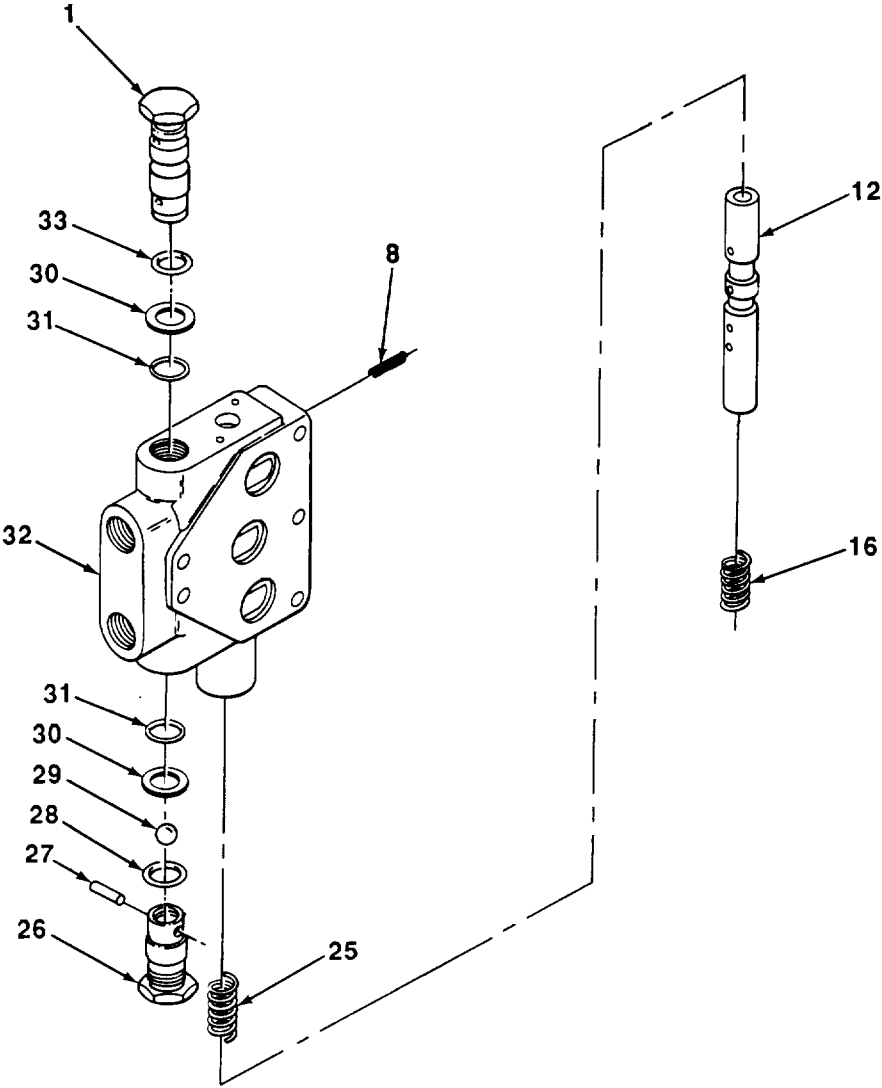

14-15. LOADER BOOM AND BUCKET VALVES REPAIR (Con't).

b. CLEANING AND INSPECTION
WARNING

- Dry cleaning solvent, P-D-680, is toxic and flammable. Always wear protective goggles and gloves, and use only in a well-ventilated area. Avoid contact with skin, eyes, and clothes, and DO NOT breathe vapors. DO NOT use near open flame or excessive heat. The solvent's flash point is 100°F-138°F (38°C-59°C). If you become dizzy while using cleaning solvent, immediately get fresh air and medical help. If solvent contacts eyes, immediately wash your eyes and get medical aid.
- Compressed air used for cleaning or drying purposes, or for clearing restrictions, should never exceed 30 psi (207 kPa). Wear protective clothing (goggles/shield, gloves, etc.) and use caution to avoid injury to personnel.

1. Clean valve body with rags dampened with dry cleaning solvent. Dry thoroughly with compressed air.
2. Clean fluid flow restrictor and valve with dry cleaning solvent and rags. Dry thoroughly with compressed air. Ensure that holes are free of material and dirt.
3. Clean all other metal parts with dry cleaning solvent. Dry thoroughly with compressed air.
4. Clean bellows with rags dampened with water and detergent solution. Rinse with clean water. Dry thoroughly
5. Inspect spring (16) for cracks, breaks, and abnormal bends. Using portable spring resiliency tester and machinist's rule, apply 8 oz (2.2 N) of force and measure compressed length of spring. Compressed length must be 0.8125 in. (20.6375 mm).
6. Inspect spring (25) for cracks, breaks, and abnormal bends. Using spring tester and torque wrench, apply 27 lb (120 N) of force and measure compressed length of spring. Compressed length must be 1.1875 in.
7. Inspect spring (8) for cracks, breaks, and abnormal bends. Using spring tester and torque wrench, apply 75 lb (334 N) of force and measure compressed length of spring. Compressed length must be 0.625 in. (15.875 mm).

NOTE

Valve body and valve are a matched set. If either part is damaged, both must be replaced.

8. Inspect valve for burrs and rough spots.
9. Inspect all other metal parts for cracks, breaks, and abnormal bends. Inspect threaded parts for damaged threads.

c. REPAIR

1. Remove rough spots or burrs from valve (12) using 600 grit abrasive cloth.
2. Restore damaged threads using pipe threading or screw threading set.

d. ASSEMBLY
NOTE

Perform steps 1 through 3 only if repairing boom valve.

1. Install ball bearing (29) and spring pin (27) in plug valve (26).
2. Install plug valve (26), new backup washer (30), and two new preformed packings (28 and 31) in valve body (32).

14-15. LOADER BOOM AND BUCKET VALVES REPAIR (Con't).

3. Install plug (1), new backup washer (30), and two new preformed packings (31 and 33).

NOTE

Perform steps 4 and 5 only if repairing bucket valve.

4. Install two new preformed packings (31) and new backup washers (30) in valve body (32).
5. Install bucket valve relief valves (see paragraph 14-16).
6. Coat new preformed packing (9), spring (8), and detent plunger (7) with hydraulic fluid. Install detent plunger, spring, preformed packing, and plug (10) in valve body (32).
7. Coat new preformed packing (13) with hydraulic fluid, then install in place on spool plug (14).

NOTE

Ensure that sealing surfaces are clean before applying thread sealing compound to spool plug.

8. Apply thread sealing compound to threads of spool plug (14).
9. Wrap valve (12) with a clean rag and place in vise with caps. Install spool plug (14) and preformed packing (13)
10. Coat fluid flow restrictor (11) and spring (25) with hydraulic fluid and install in place on valve (12).
11. Coat new preformed packing (24) with hydraulic fluid and install in place on clevis rod end (23).

NOTE

Ensure that sealing surfaces are clean before applying thread sealing compound to clevis rod end.

12. Apply thread sealing compound to threads of clevis rod end (23). Install clevis rod end and assembled parts on valve (12). Remove valve from vise.
13. Coat new preformed packing (21) and sleeve bushing (22) with hydraulic fluid. Install sleeve bushing and preformed packing in valve body (32).
14. Coat valve (12) and assembled parts with hydraulic fluid and slide into valve body (32).

NOTE

Perform step 15 only if repairing boom valve. Perform step 16 only if repairing bucket valve.

15. Install sleeve spacer (18), spring (16), and washer (15) in valve body (32).
16. Install sleeve spacers (17 and 18), spring (16), and washer (15) in valve body (32).
17. Hold clevis rod end (23) to prevent turning. Install spool spring screw (19) in spool plug (14). Torque spool spring screw to 5-8 lb.-ft. (7-11 N•m).
18. Place valve body (32) in vise with caps. Install valve cap (20) in valve body. Remove valve body from vise.
19. Install new preformed packing (6), washer (5), bellows (2), and protective dust cap (4) over clevis rod end (23) and secure with two screws (3).

14-15. LOADER BOOM AND BUCKET VALVES REPAIR (Con't).

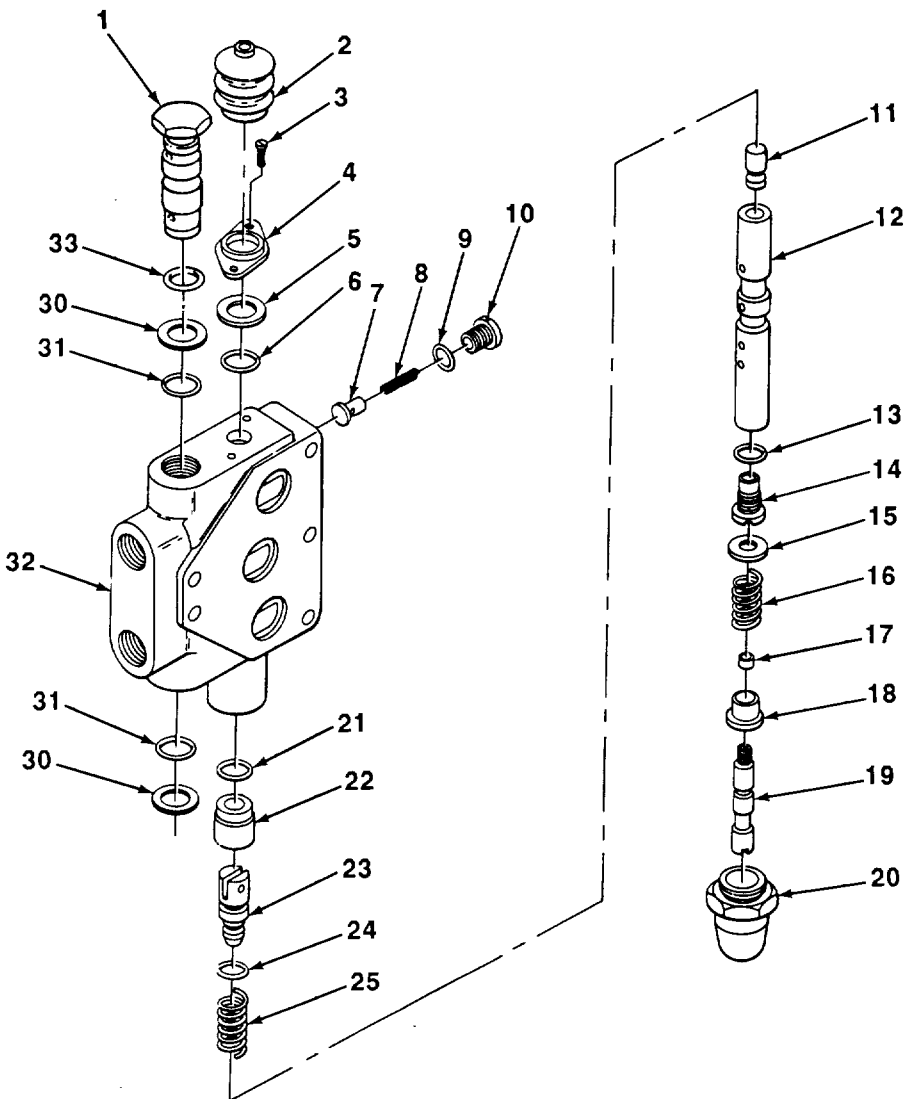

FOLLOW-ON TASKS:

- Assemble loader control valve assembly (see paragraph 14-14).

14-16. LOADER BUCKET RELIEF VALVES MAINTENANCE.*This Task Covers:*

- | | |
|----------------------------|-----------------|
| a. Removal | e. Assembly |
| b. Disassembly | f. Installation |
| c. Cleaning and Inspection | g. Adjustment |
| d. Repair | |

*Initial Setup:***Equipment Conditions:**

- Loader control valve assembly removed (see TM 5-2420-222-20).

Tools/Test Equipment:

- General mechanic's tool kit
- Field automotive shop set

Materials/Parts:

- Hydraulic fluid (Item 15, Appendix B)
- Rags (Item 28, Appendix B)
- Dry cleaning solvent (Item 31, Appendix B)
- One repair kit
- Two preformed packings

References:

- TM 5-2420-222-20

General Safety Instructions:

- Dry cleaning solvent is flammable and must not be used near open flame. Use only in a well-ventilated area.
- Compressed air used for cleaning purposes should never exceed 30 psi (207 kPa).

a. REMOVAL

Remove relief valve (1) with assembled parts and preformed packing (3) from valve body (2). Discard preformed packing.

b. DISASSEMBLY

1. Using retaining ring pliers, remove retaining ring (7) from relief valve (1).
2. Remove retainer (8) from relief valve (1).
3. Wrap relief valve (1) with a clean rag and place in vise with caps. Push down on valve seat (13) and compress
4. Remove vent plug (9) and preformed packing (10) from relief valve (1). Discard preformed packing.
5. Remove relief valve (1) from vise.
6. Remove valve seat (13), preformed packing (11), washer (12), spring (6), and spring holder (4) with assembled shims (5) from relief valve (1). Discard preformed packing.

NOTE

Note size and number of shims to ensure proper assembly.

7. Remove shims (5) from spring holder (4).

14-16. LOADER BUCKET RELIEF VALVES MAINTENANCE (Con't).

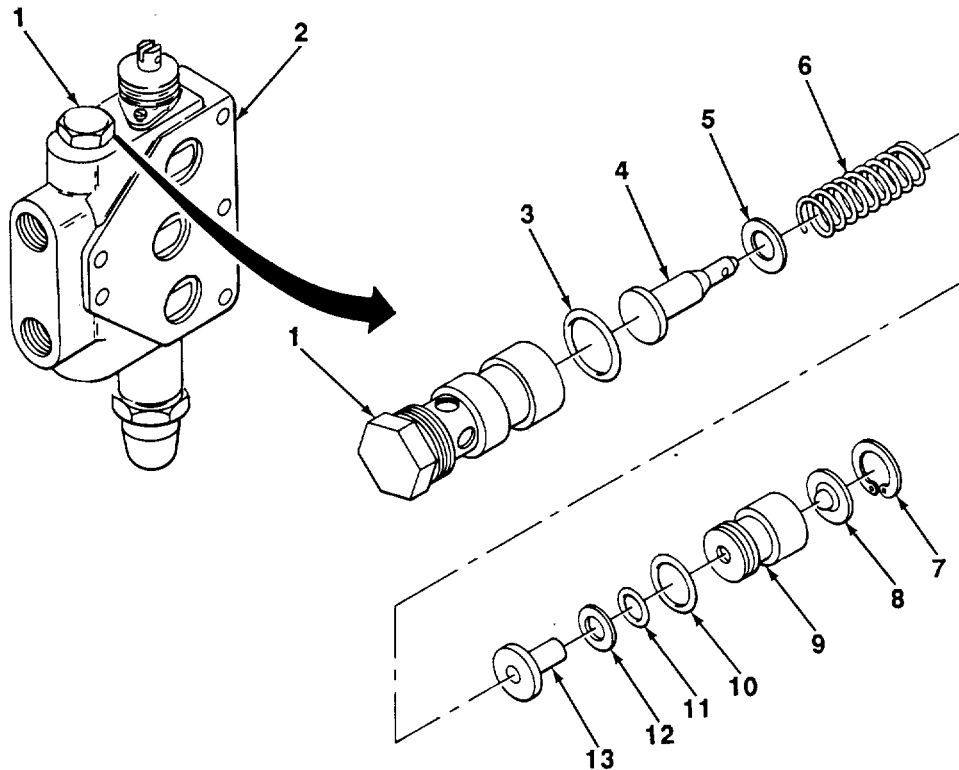

c. CLEANING AND INSPECTION

WARNING

- Dry cleaning solvent, P-D-680, is toxic and flammable. Always wear protective goggles and gloves, and use only in a well-ventilated area. Avoid contact with skin, eyes, and clothes, and DO NOT breathe vapors. DO NOT use near open flame or excessive heat. The solvent's flash point is 100°F-138°F (38°C-59°C). If you become dizzy while using cleaning solvent, immediately get fresh air and medical help. If solvent contacts eyes, immediately wash your eyes and get medical aid.
- Compressed air used for cleaning or drying purposes, or for clearing restrictions, should never exceed 30 psi (207 kPa). Wear protective clothing (goggles/shield, gloves, etc.) and use caution to avoid injury to personnel.

1. Clean all metal parts with dry cleaning solvent. Dry thoroughly with compressed air.
2. Inspect spring for cracks, breaks, and abnormal bends. Using spring tester and torque wrench, compress spring with 122 lb (543 N) of force and measure compressed length of spring. Compressed length must be 1.5 in. (38.1 mm).
3. Inspect all other metal parts for cracks, breaks, and abnormal bends. Inspect threaded parts for damaged threads.

d. REPAIR

Restore any damaged threads using screw threading set.

14-16. LOADER BUCKET RELIEF VALVES MAINTENANCE (Con't).**e. ASSEMBLY**

1. Install proper size and number of shims (5), as noted during disassembly, on spring holder (4).
2. Coat spring holder (4) and shims (5) with hydraulic fluid, and install in relief valve (1).
3. Coat spring (6) with hydraulic fluid. Install spring in relief valve (1).
4. Coat new preformed packing (10) with hydraulic fluid. Install preformed packing on vent plug (9).
5. Coat valve seat (13), washer (12), and new preformed packing (11) with hydraulic fluid. Install washer and new preformed packing on valve seat.
6. Install valve seat (13) with assembled parts on vent plug (9).
7. Wrap relief valve (1) with a clean rag and place in vise with caps. Install vent plug (9) and assembled parts in relief valve.
8. Push down on valve seat (13) and compress spring (6). Tighten vent plug (9) and assembled parts. relief valve.
9. Coat retainer (8) with hydraulic fluid. Install retainer in relief valve (1).
10. Using retainer ring pliers, install retaining ring (7) in relief valve (1). Remove relief valve from vise.

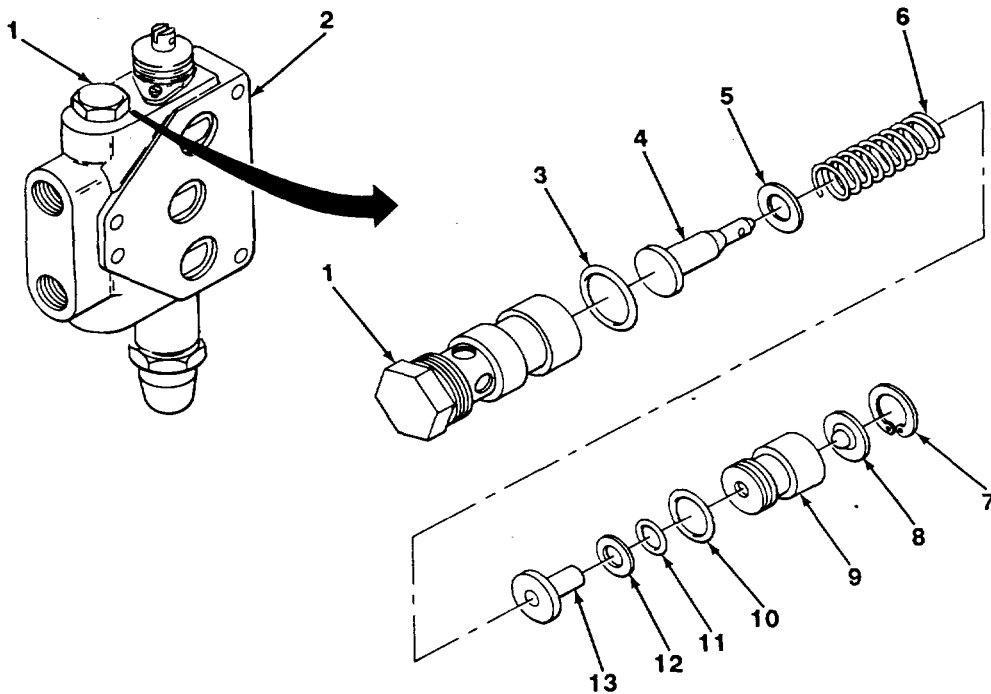
**f. INSTALLATION**

1. Coat new preformed packing (3) with hydraulic fluid. Install preformed packing on relief valve (1).
2. Install relief valve (1) and assembled parts in valve body (2).

14-16. LOADER BUCKET RELIEF VALVES MAINTENANCE (Con't).**g. ADJUSTMENT**

1. If installed, remove loader control valve assembly (see TM 5-2420-222-20).
2. Connect proof pressure tester to valve cap (14).
3. Using four 3/4 in. -14 NPT pipe plugs, plug boom valve (17) and 0bucket valve (16).
4. Using proof pressure tester, pump up hydraulic pressure to 1800 psi (12,411 kPa) and check for leaks. Tighten all leaking connections. If leaking does not stop, release pressure and replace defective part.

NOTE

All relief valves are adjusted the same way. Repeat steps 5 through 9 for other relief valve as required.

5. Push clevis rod end (15) down to check top relief valve (1) or pull up to check bottom relief valve.

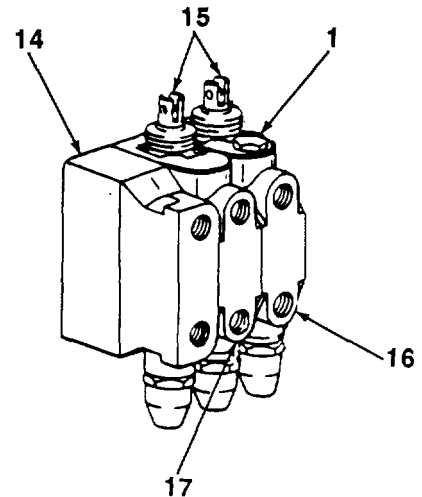
**WARNING**

Relief valves are stamped with pressure limit. Bucket (lower) relief valve pressure limit is 1500 psi (10,343 kPa). Bucket (raise) relief valve pressure limit is 2750 psi (18,961 kPa). Do not exceed stamped pressure limit. Serious injury to personnel may result.

6. Using proof pressure tester, pump up hydraulic pressure until relief valve (1) opens or pressure limit of relief valve is reached.

NOTE

If relief valve opening pressure is correct, skip steps 7 through 9.

7. Remove and disassemble relief valve (see subparagraphs a and b).
8. If opening pressure was more than specified, remove shims (5). If opening pressure was less than specified limit, add shims as required.
9. Assemble, install, and adjust relief valve (see subparagraphs e, f, and g).

FOLLOW-ON TASKS:

- Install loader control valve assembly (see TM 5-2420-222-20).

14-17. HYDRAULIC HOSES, LINES, AND FITTINGS REPAIR.

To repair hydraulic hoses, lines, and fittings, refer to General Maintenance instructions (see paragraphs 1-25 and 1-27).

14-18. JAW CYLINDER ASSEMBLY REPAIR.

This Task Covers:

- | | |
|----------------------------|-------------|
| a. Disassembly | c. Repair |
| b. Cleaning and Inspection | d. Assembly |
-

*Initial Setup:***Equipment Conditions:**

- Jaw cylinder assembly removed (see TM 5-2420-222-20).

Tools/Test Equipment:

- General mechanic's tool kit
- Field automotive shop set

Materials/Parts:

- Abrasive cloth (Item 6, Appendix B)
- Hydraulic fluid (Item 15, Appendix B)
- Rags (Item 28, Appendix B)
- Dry cleaning solvent (Item 31, Appendix B)
- Seven preformed packings

Personnel Required: Two

General Safety Instructions:

- Dry cleaning solvent is flammable and must not be used near open flame. Use only in a well-ventilated area.
 - Compressed air used for cleaning purposes should never exceed 30 psi (207 kPa).
-

a. DISASSEMBLY

1. Place hydraulic cylinder block (4) in vise with caps.
2. Remove lubrication fitting (3) from hydraulic cylinder block (4).
3. Remove electrical box connector (1) and preformed packing (2) from hydraulic cylinder block (4). Discard preformed packing.
4. Using spanner wrench, loosen retainer (13) from hydraulic cylinder block (4). Slide retainer back onto piston rod (11).

NOTE

Use a drain pan to catch fluid when draining hydraulic cylinder block. Clean up all spills.

5. Loosen vise and tilt hydraulic cylinder block (4) to drain hydraulic fluid.
6. Tighten vise. With the aid of an assistant, remove piston rod (11) with assembled parts from hydraulic cylinder block (4).

14-18. JAW CYLINDER ASSEMBLY REPAIR (Con't).

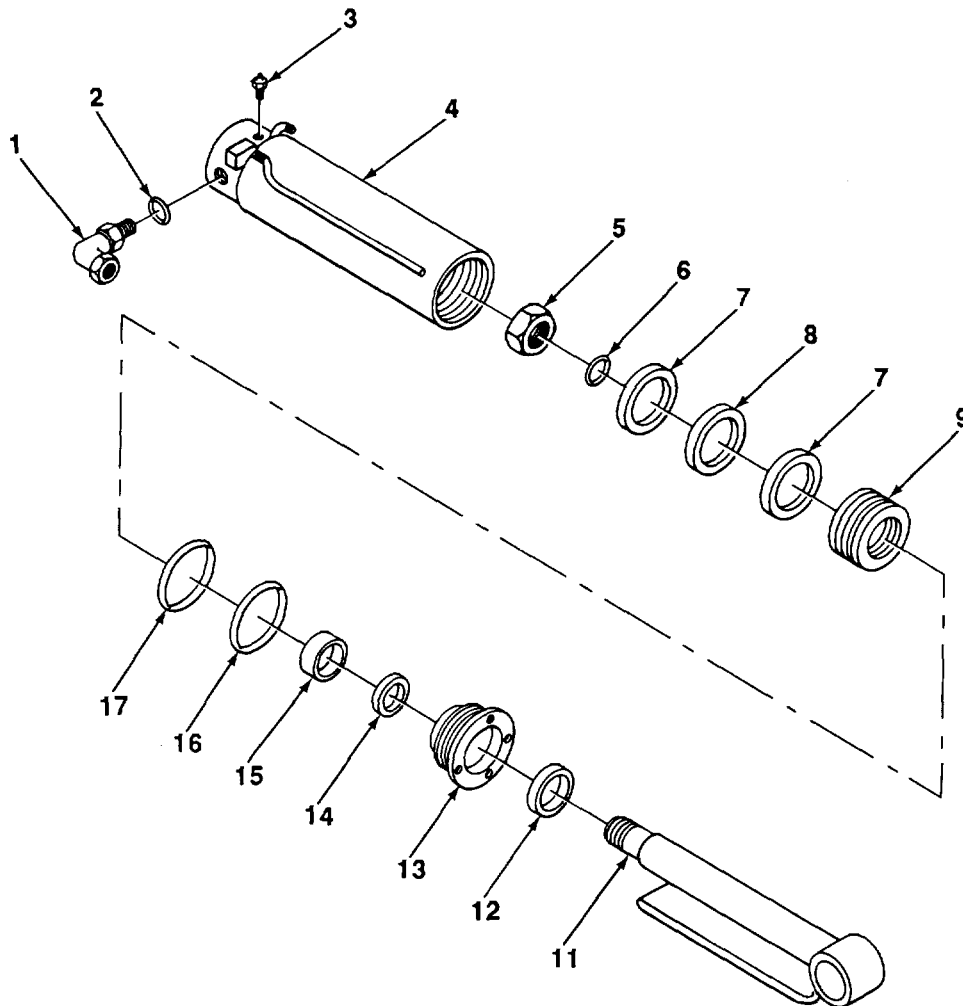

7. Remove hydraulic cylinder block (4) from vise.
8. Place piston rod (11) in vise with caps. Remove nut (5) and preformed packing (6) from piston rod. Discard preformed packing.
9. Tap piston (9) with assembled parts loose and remove from piston rod (11). Remove piston rod from vise.
10. Remove retainer (13) with assembled parts from piston rod (11).
11. Remove two preformed packings (7) and packing retainer (8) from piston (9). Discard preformed packings.
12. Remove preformed packing (17), packing retainer (16), preformed packing (15), sleeve bearing (14), and preformed packing (12) from retainer (13). Discard preformed packings.

TA701607

14-18. JAW CYLINDER ASSEMBLY REPAIR (Con't).

CAUTION

Do not remove sleeve bushings unless damaged. Removal may damage parts.

13. Drive two sleeve bushings (10) out of piston rod (11).

b. CLEANING AND INSPECTION**WARNING**

- **Dry cleaning solvent, P-D-680, is toxic and flammable. Always wear protective goggles and gloves, and use only in a well-ventilated area. Avoid contact with skin, eyes, and clothes, and DO NOT breathe vapors. DO NOT use near open flame or excessive heat. The solvent's flash point is 100°F-138°F (38°C - 59°C). If you become dizzy while using cleaning solvent, immediately get fresh air and medical help. If solvent contacts eyes, immediately wash your eyes and get medical aid.**
- **Compressed air used for cleaning or drying purposes, or for clearing restrictions, should never exceed 30 psi (207 kPa). Wear protective clothing (goggles/shield, gloves, etc.) and use caution to avoid injury to personnel.**

1. Clean all metal parts with rags dampened with dry cleaning solvent. Dry thoroughly with compressed air.
2. Inspect hydraulic cylinder block for cracks, breaks, chips, and excessive scoring inside hydraulic cylinder block.
3. Inspect piston rod for cracks, breaks, and excessive scoring.
4. Inspect all threaded parts for damaged threads.

c. REPAIR

1. Remove any minor scoring from hydraulic cylinder block (4) or piston rod (11) using 600 grit abrasive cloth.
2. Restore damaged threads using pipe threading or screw threading set.

d. ASSEMBLY**NOTE**

Perform step 1 only if sleeve bushings were removed.

1. Drive two sleeve bushings (10) into piston rod (11).
2. Coat new preformed packings (12, 15, and 17), packing retainer (16), and sleeve bearing (14) with hydraulic fluid.
3. Install preformed packings (12, 15, and 17), packing retainer (16), and sleeve bearing (14) in place on retainer (13).
4. Install retainer (13) with assembled parts in place on piston rod (11).
5. Coat two new preformed packings (7) and packing retainer (8) with hydraulic fluid.
6. Install two preformed packings (7) and packing retainer (8) in place on piston (9).

14-18. JAW CYLINDER ASSEMBLY REPAIR (Con't).

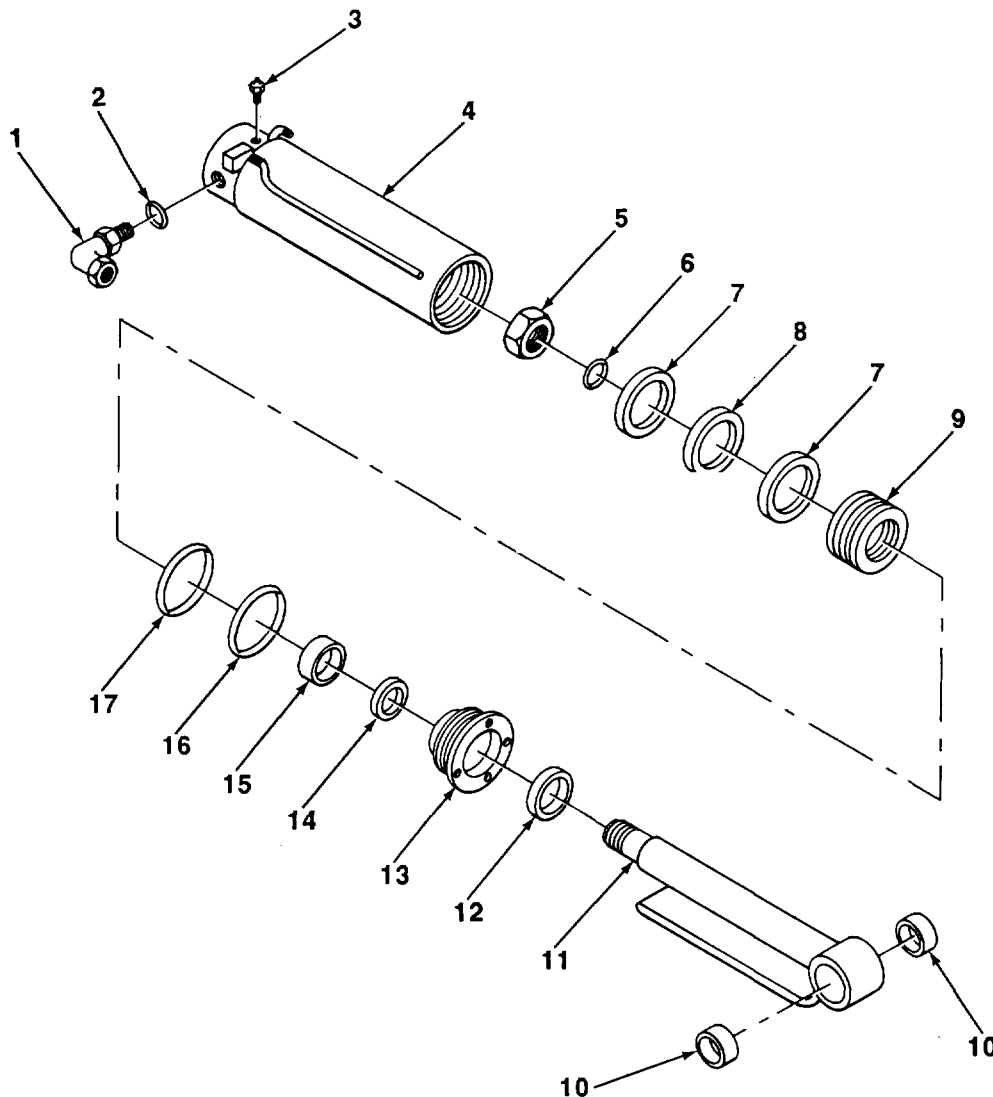

7. Place piston rod (11) in vise with caps. Tap piston (9) with assembled parts in place on piston rod.
8. Install new preformed packing (6) and nut (5) on piston rod (11). Remove piston rod from vise.
9. Place hydraulic cylinder block (4) in vise with caps. With the aid of an assistant, install piston rod (11) with assembled parts in hydraulic cylinder block.
10. Using spanner wrench, tighten retainer (13) in hydraulic cylinder block (4).
11. Install electrical box connector (1) and new preformed packing (2) in hydraulic cylinder block (4).
12. Install lubrication fitting (3) in hydraulic cylinder block (4). Remove hydraulic cylinder block with assembled parts from vise.

FOLLOW-ON TASKS:

- Install jaw cylinder assembly (see TM 5-2420-222-20).

TA701608

14-19. BACKHOE CROWD CYLINDER ASSEMBLY REPAIR.*This Task Covers:*

- | | | | |
|----|-------------------------|----|----------|
| a. | Disassembly | c. | Repair |
| b. | Cleaning and Inspection | d. | Assembly |

*Initial Setup:***Equipment Conditions:**

- Backhoe crowd cylinder assembly removed (see TM 5-2420-222-20).
- Rags (Item 28, Appendix B)
- Dry cleaning solvent (Item 31, Appendix B)

Tools/Test Equipment:

- General mechanic's tool kit
- Field automotive shop set

General Safety Instructions:

- Dry cleaning solvent is flammable and must not be used near open flame. Use only in a well-ventilated area.
- Compressed air used for cleaning purposes should never exceed 30 psi (207 kPa).

Materials/Parts:

- Abrasive cloth (Item 6, Appendix B)
- Hydraulic fluid (Item 15, Appendix B)
- Two preformed packings (serial numbers 319995-342573)
- Two self-locking nuts (serial numbers 235786-235999)
- Two V-packings
- Two wear rings
- Eight preformed packings (serial numbers 235786-235999)

Personnel Required: Two**a. DISASSEMBLY****NOTE**

Steps 1 through 3 apply only to loader backhoes with serial numbers 235786-235999.

1. Remove two self-locking nuts (6), ferrules (5), preformed packings (3), and packing retainers (4) from adapters (2). Discard self-locking nuts and preformed packings.
2. Remove two adapters (2) and preformed packings (1) from actuating cylinder (29). Discard preformed packings.
3. Remove two tubes and fittings (7) and preformed packings (8) from actuating cylinder (29). Discard preformed packings.
4. Place actuating cylinder (29) in vise with caps.
5. Remove lubrication fitting (27) and setscrew (9) from actuating cylinder (29).
6. Using spanner wrench, loosen valve stem guide (21) from actuating cylinder (29). Slide valve stem guide back onto piston rod (19).

NOTE

Use a drain pan to catch fluid when draining actuating cylinder. Clean up all spills.

7. Loosen vise and tilt actuating cylinder (29) to drain hydraulic fluid.
8. Tighten vise. With the aid of an assistant, remove piston rod (19) with assembled parts from actuating cylinder (29).

14-19. BACKHOE CROWD CYLINDER ASSEMBLY REPAIR (Con't).

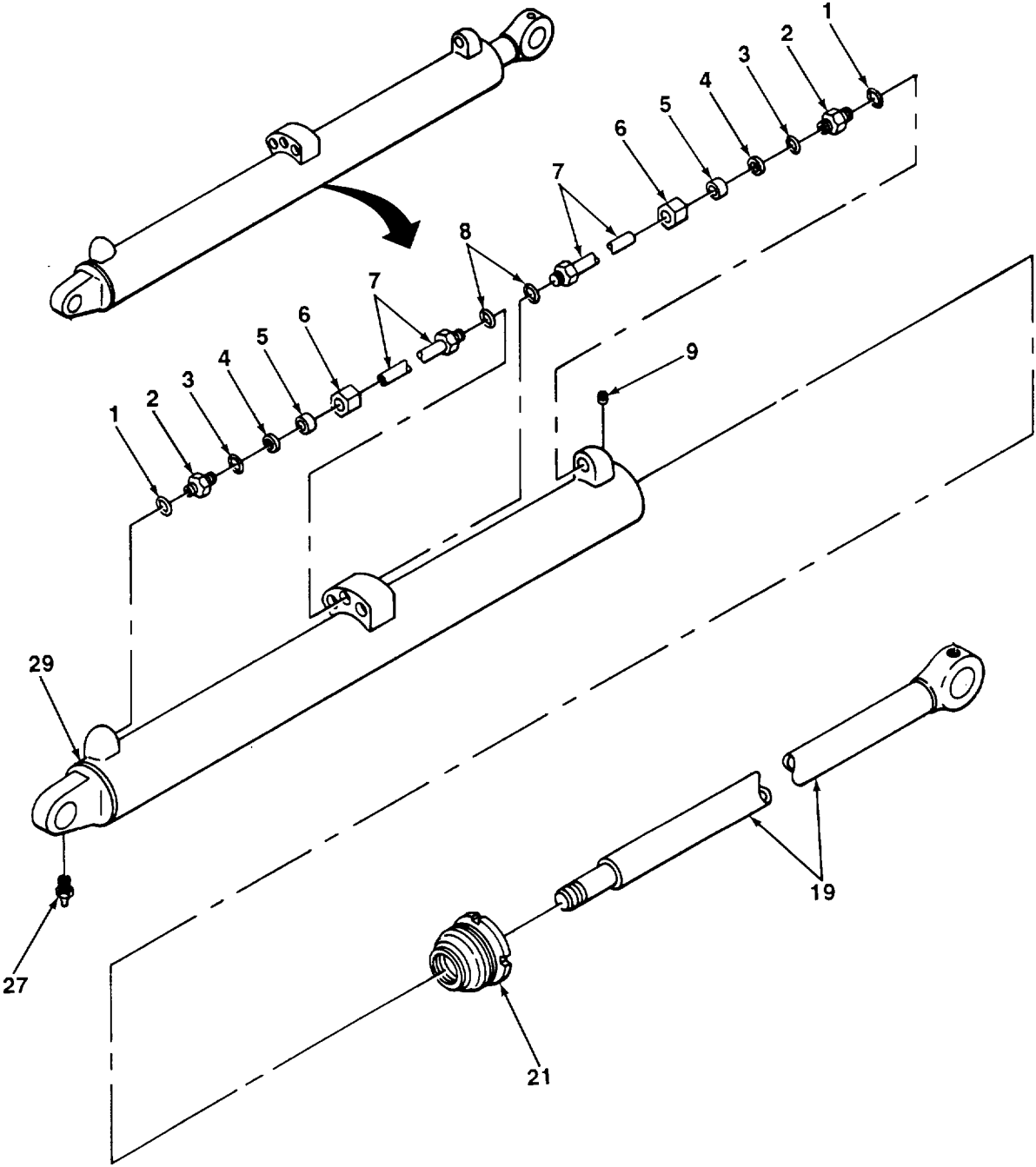

TA701609

14-19. BACKHOE CROWD CYLINDER ASSEMBLY REPAIR (Con't).

9. Remove actuating cylinder (29) from vise.
10. Place piston rod (19) in vise with caps. Remove nut (16) from piston rod.
11. Tap pistons (15 and 11) with assembled parts loose and remove from piston rod (19). Remove piston rod from vise.
12. Remove valve stem guide (21) with assembled parts from piston rod (19).
13. Remove wear ring (14) and V-packing (13) from piston (15). Discard wear ring and V-packing.
14. Remove preformed packing (12), piston ring (10), preformed packing (26), and packing retainer (25) from piston (11). Discard preformed packings.
15. Using retaining ring pliers, remove retaining ring (24) from valve stem guide (21).
16. Remove V-packing (23), wear ring (22), and wiper seal (20) from valve stem guide (21). Discard V-packing and wear ring.
17. Remove lubrication fitting (17) from piston rod (19).

CAUTION

Do not remove sleeve bushings unless damaged. Removal may damage parts.

18. Drive sleeve bushing (18 or 28) out of piston rod (19) or actuating cylinder (29).

b. CLEANING AND INSPECTION**WARNING**

- **Dry cleaning solvent, P-D-680, is toxic and flammable. Always wear protective goggles and gloves, and use only in a well-ventilated area. Avoid contact with skin, eyes, and clothes, and DO NOT breathe vapors. DO NOT use near open flame or excessive heat. The solvent's flash point is 100°F-138°F (38°C-59°C). If you become dizzy while using cleaning solvent, immediately get fresh air and medical help. If solvent contacts eyes, immediately wash your eyes and get medical aid.**
- **Compressed air used for cleaning or drying purposes, or for clearing restrictions, should never exceed 30 psi (207 kPa). Wear protective clothing (goggles/shield, gloves, etc.) and use caution to avoid injury to personnel.**

1. Clean all metal parts with rags dampened with dry cleaning solvent. Dry thoroughly with compressed air.
2. Inspect actuating cylinder for cracks, breaks, chips, and excessive scoring inside actuating cylinder.
3. Inspect piston rod for cracks, breaks, and excessive scoring.
4. Inspect sleeve bushings for cracks, breaks, and excessive scoring.
5. Inspect all metal parts for cracks, breaks, and abnormal bends.
6. Inspect all threaded parts for damaged threads.

c. REPAIR

1. Remove any minor scoring from actuating cylinder (29) or piston rod (19) using 600 grit abrasive cloth.
2. Restore damaged threads using pipe threading or screw threading set.

14-19. BACKHOE CROWD CYLINDER ASSEMBLY REPAIR (Con't).

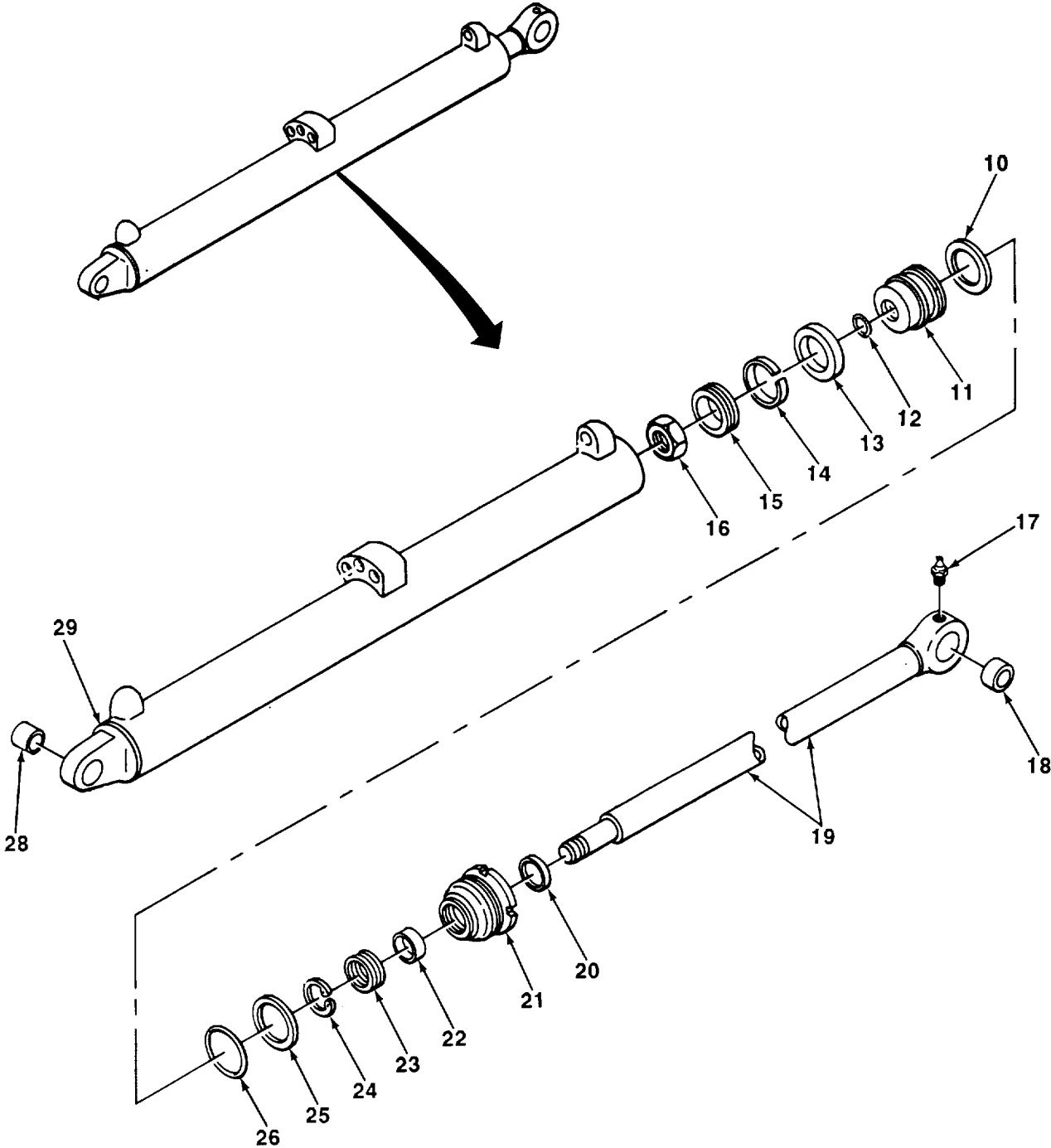

14-19. BACKHOE CROWD CYLINDER ASSEMBLY REPAIR (Con't).

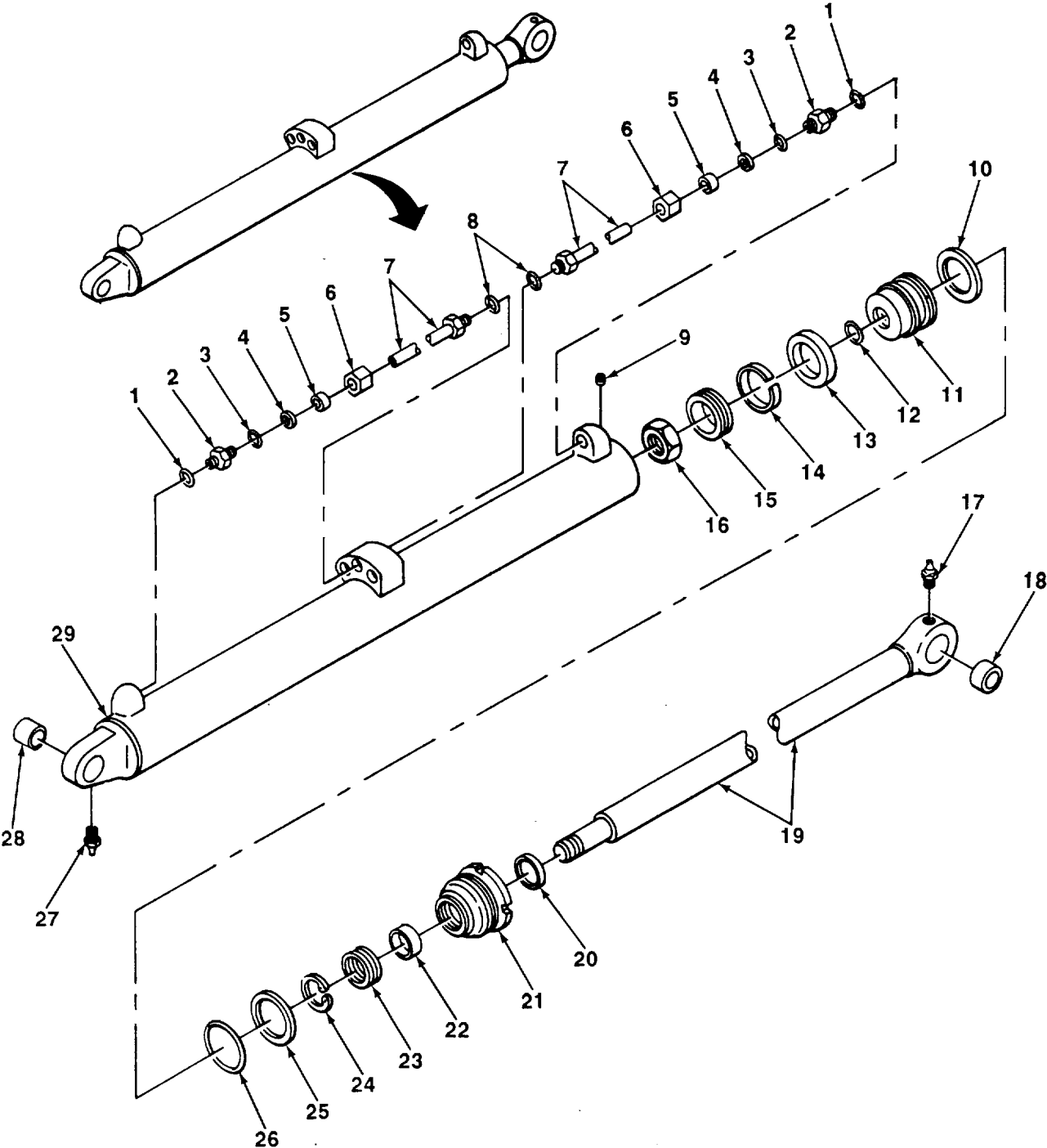

TA701611

14-19. BACKHOE CROWD CYLINDER ASSEMBLY REPAIR (Con't).

d. ASSEMBLY**NOTE**

Perform step 1 only if sleeve bushings were removed.

1. Drive sleeve bushing (18 or 28) in piston rod (19) or actuating cylinder (29).
2. Coat new V-packing (23), new wear ring (22), and wiper seal (20) with hydraulic fluid.
3. Install V-packing (23), wear ring (22), and wiper seal (20) in place on valve stem guide (21).
4. Using retaining ring pliers, install retaining ring (24) in valve stem guide (21).
5. Install valve stem guide (21) with assembled parts in place on piston rod (19).
6. Coat two new preformed packings (12 and 26), piston ring (10) and packing retainer (25) with hydraulic fluid.
7. Install two preformed packings (12 and 26), piston ring (10) and packing retainer (25) in place on piston (11).
8. Place piston rod (19) in vise with caps. Tap piston (11) with assembled parts in place on piston rod.
9. Coat new V-packing (13) and new wear ring (14) with hydraulic fluid.
10. Install V-packing (13) and wear ring (14) in place on piston (15). Tap piston with assembled parts in place on piston rod (19).
11. Install nut (16) on piston rod (19) and remove piston rod from vise.
12. Place actuating cylinder (29) in vise with caps. With the aid of an assistant, install piston rod (19) with assembled parts in actuating cylinder.
13. Using spanner wrench, tighten valve stem guide (21) in actuating cylinder (29). Install setscrew (9).
14. Install lubrication fittings (17 and 27) in piston rod (19) and actuating cylinder (29).

NOTE

Steps 15 through 17 apply only to loader backhoes with serial numbers 235786-235999.

15. Install two tubes and fittings (7) and new preformed packings (8) in actuating cylinder (29).
16. Install two adapters (2) and new preformed packings (1) in actuating cylinder (29).
17. Install two new self-locking nuts (6), preformed packings (3), ferrules (5) and packing retainers (4) on adapters (2).
18. Remove hydraulic cylinder (29) with assembled parts from vise.

FOLLOW-ON TASKS:

- Install backhoe crowd cylinder assembly (see TM 5-2420-222-20).

14-20. BACKHOE BOOM CYLINDER ASSEMBLY REPAIR.

This Task Covers:

- | | |
|----------------------------|-------------|
| a. Disassembly | c. Repair |
| b. Cleaning and Inspection | d. Assembly |
-

Initial Setup:

Equipment Conditions:

- Backhoe boom cylinder assembly removed (see TM 5-2420-222-20).

Tools/Test Equipment:

- General mechanic's tool kit
- Field automotive shop set

Materials/Parts:

- Abrasive cloth (Item 6, Appendix B)
- Hydraulic fluid (Item 15, Appendix B)
- Rags (Item 28, Appendix B)
- Dry cleaning solvent (Item 31, Appendix B)
- One repair kit

General Safety Instructions:

- Dry cleaning solvent is flammable and must not be used near open flame. Use only in a well-ventilated area.
 - Compressed air used for cleaning purposes should never exceed 30 psi (207 kPa).
-

Personnel Required: Two**a. DISASSEMBLY**

1. Place actuating cylinder (3) in vise with caps.
2. Remove setscrew (4) from actuating cylinder (3).
3. Remove lubrication fitting (2) from actuating cylinder (3).
4. Using spanner wrench, loosen valve stem guide (11) from actuating cylinder (3). Slide valve stem guide back onto piston rod (8).

NOTE

Use a drain pan to catch fluid when draining actuating cylinder. Clean up all spills.

5. Loosen vise and tilt actuating cylinder (3) to drain hydraulic fluid.
6. Tighten vise. With the aid of an assistant, remove piston rod (8) with assembled parts from actuating cylinder (3).
7. Remove actuating cylinder (3) from vise.
8. Place piston rod (8) in vise with caps. Remove nut (5) from piston rod.
9. Tap pistons (13 and 17) with assembled parts loose and remove from piston rod (8). Remove piston rod from vise.
10. Remove valve stem guide (11) with assembled parts from piston rod (8).
11. Remove piston ring (6) and wear ring (14) from piston (13). Discard wear ring.
12. Remove V-packing (15) and preformed packing (16) from piston (17). Discard V-packing and preformed packing.

14-20. BACKHOE BOOM CYLINDER ASSEMBLY REPAIR (Con't).

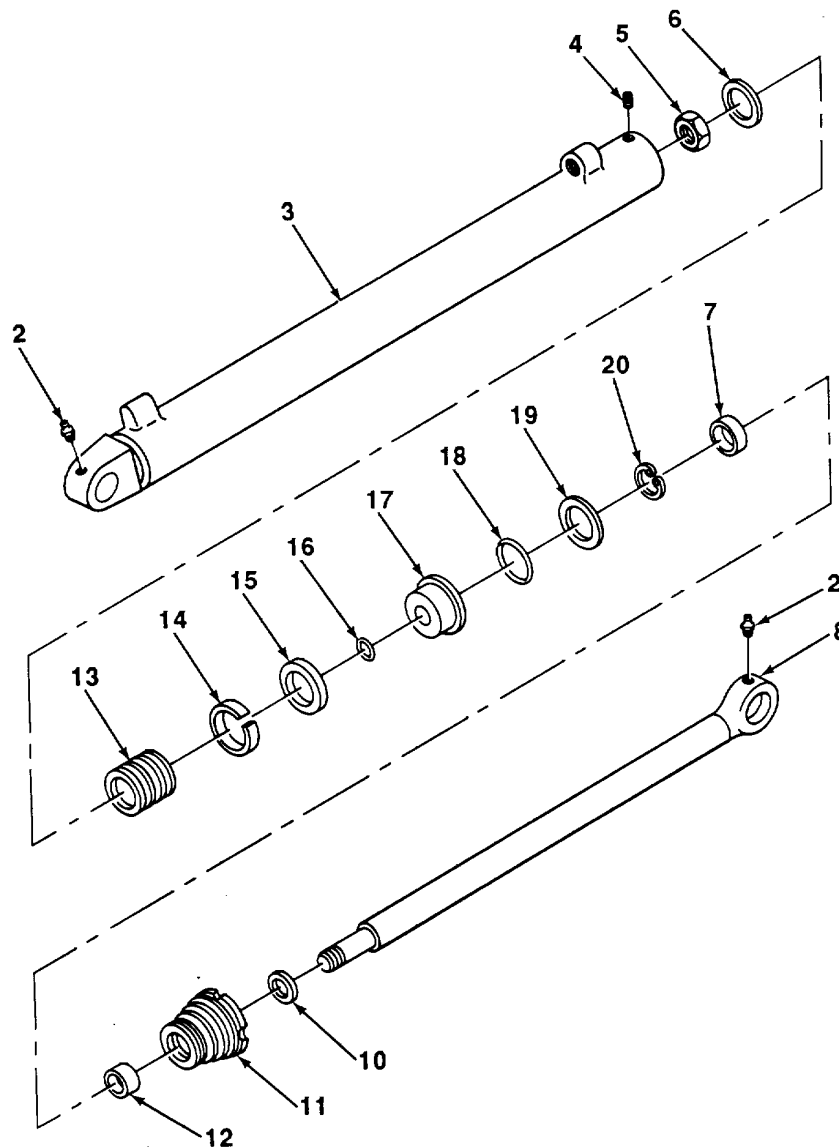
**NOTE**

**Loader backhoes with serial numbers 235786-235999 have a backup washer.
 Loader backhoes with serial numbers 319995-342573 have a packing retainer.**

13. Remove backup washer or packing retainer (19) and preformed packing (18) from piston (17). Discard backup washer or packing retainer and preformed packing.
14. Using retaining ring pliers, remove retaining ring (20) from valve stem guide (11).
15. Remove V-packing (7), wear ring (12), and wiper seal (10) from valve stem guide (11). Discard V-packing, wear ring, and wiper seal.
16. Remove lubrication fitting (2) from piston rod (8).

TA701612

14-20. BACKHOE BOOM CYLINDER ASSEMBLY REPAIR (Con't).

CAUTION

Do not remove sleeve bushings unless damaged. Removal may damage parts.

17. Drive sleeve bushing (1 or 9) out of actuating cylinder (3) or piston rod (8).

b. CLEANING AND INSPECTION**WARNING**

- Dry cleaning solvent, P-D-680, is toxic and flammable. Always wear protective goggles and gloves, and use only in a well-ventilated area. Avoid contact with skin, eyes, and clothes, and DO NOT breathe vapors. DO NOT use near open flame or excessive heat. The solvent's flash point is 100°F - 138°F (38°C - 59°C). If you become dizzy while using cleaning solvent, immediately get fresh air and medical help. If solvent contacts eyes, immediately wash your eyes and get medical aid.
- Compressed air used for cleaning or drying purposes, or for clearing restrictions, should never exceed 30 psi (207 kPa). Wear protective clothing (goggles/shield, gloves, etc.) and use caution to avoid injury to personnel.

1. Clean all metal parts with rags dampened with dry cleaning solvent. Dry thoroughly with compressed air.
2. Inspect actuating cylinder for cracks, breaks, chips, and excessive scoring inside actuating cylinder.
3. Inspect piston rod for cracks, breaks, and excessive scoring.
4. Inspect sleeve bushings for cracks, breaks, and excessive scoring.
5. Inspect all metal parts for cracks, breaks, and abnormal bends.
6. Inspect all threaded parts for damaged threads.

c. REPAIR

1. Remove any minor scoring from actuating cylinder (3) or piston rod (8) using 600 grit abrasive cloth.
2. Restore damaged threads using pipe threading or screw threading set.

d. ASSEMBLY**NOTE**

Perform step 1 only if sleeve bushings were removed.

1. Drive sleeve bushing (1 or 9) in actuating cylinder (3) or piston rod (8).
2. Coat new V-packing (7), new wear ring (12), and new wiper seal (10) with hydraulic fluid.
3. Install V-packing (7), wear ring (12), and wiper seal (10) in place on valve stem guide (11).
4. Using retaining ring pliers, install retaining ring (20) in valve stem guide (11).
5. Install valve stem guide (11) with assembled parts in place on piston rod (8).

14-20. BACKHOE BOOM CYLINDER ASSEMBLY REPAIR (Con't).

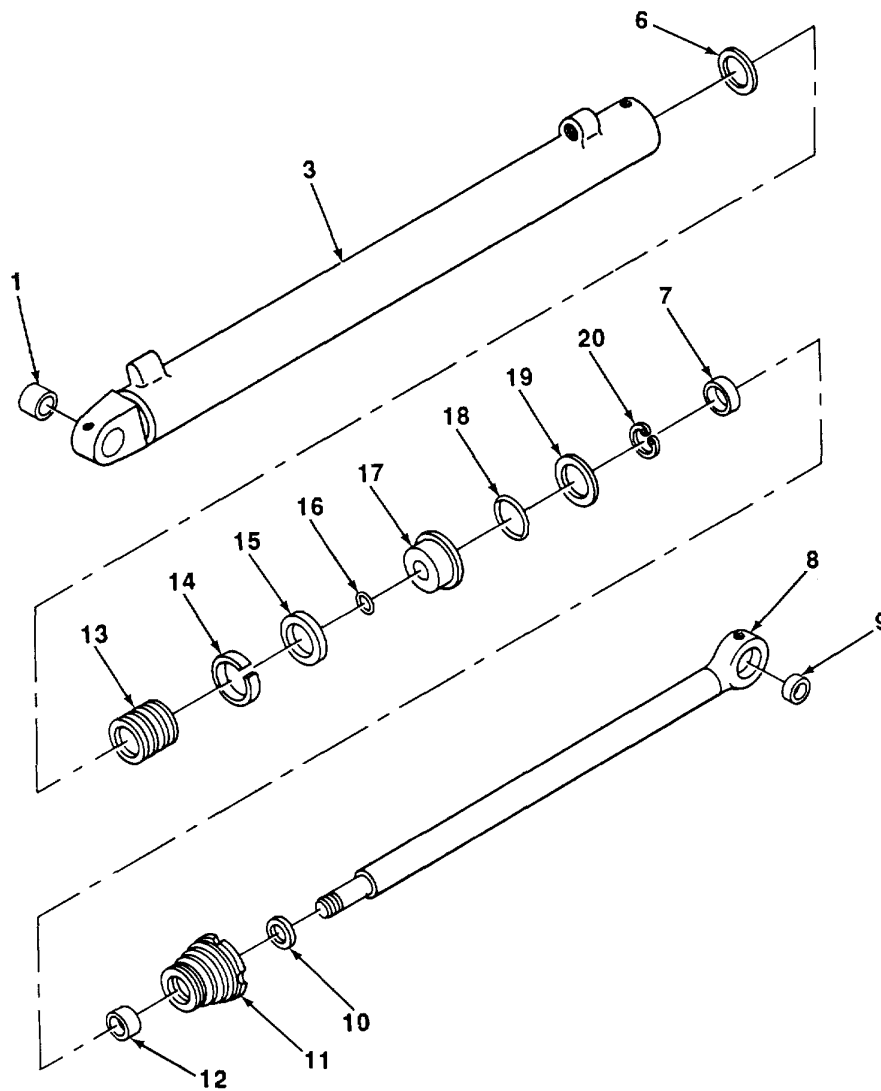

6. Coat two new preformed packings (16 and 18), new V-packing (15) and new packing retainer (19) with hydraulic fluid.

NOTE

**Loader backhoes with serial numbers 235786-235999 have a backup washer.
Loader backhoes with serial numbers 319995-342573 have a packing retainer.**

7. Install two preformed packings (16 and 18), V-packing (15) and packing retainer (19) in place on piston (17).
8. Place piston rod (8) in vise with caps. Tap piston (17) with assembled parts in place on piston rod.
9. Coat piston ring (6) and new wear ring (14) with hydraulic fluid.
10. Install piston ring (6) and wear ring (14) in place on piston (13). Tap piston with assembled parts in place on piston rod (8).

TA701613

14-20. BACKHOE BOOM CYLINDER ASSEMBLY REPAIR (Con't).

11. Install nut (5) on piston rod (8) and remove piston rod from vise.
12. Place actuating cylinder (3) in vise with caps. With the aid of an assistant, install piston rod (8) with assembled parts in actuating cylinder.
13. Using spanner wrench, tighten valve stem guide (11) in actuating cylinder (3).
14. Install lubrication fittings (2) in actuating cylinder (3) and piston rod (8).
15. Install setscrew (4) in actuating cylinder (3) to secure valve stem guide (11).
16. Remove actuating cylinder (3) with assembled parts from vise.

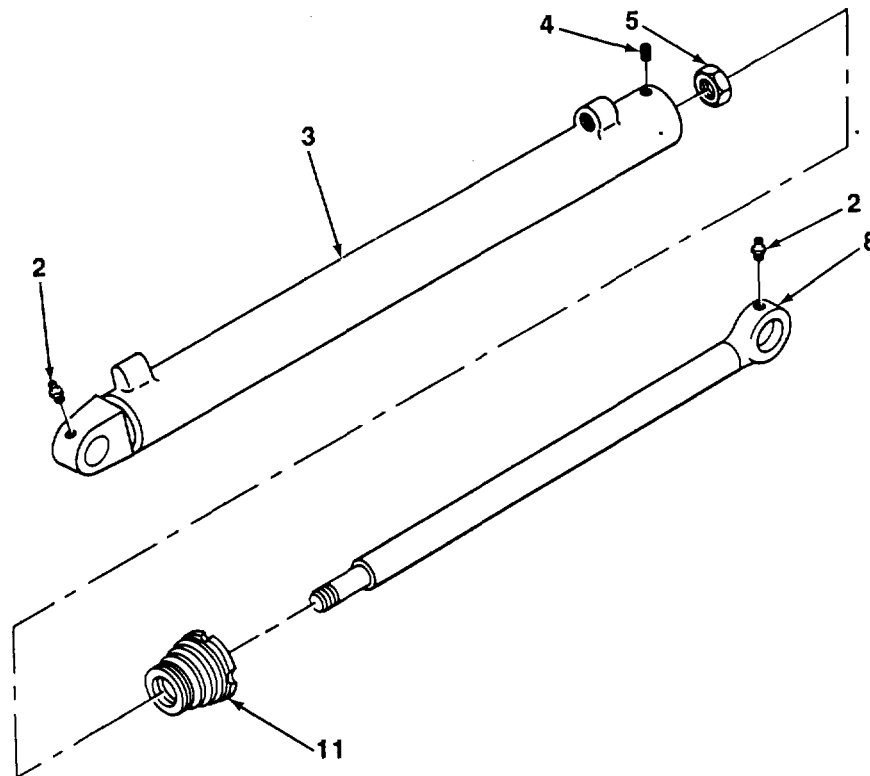
**FOLLOW-ON TASKS:**

- Install backhoe boom cylinder assembly (see TM 5-2420-222-20).

TA701614

14-21. BACKHOE BUCKET CYLINDER ASSEMBLY REPAIR.*This Task Covers:*

- | | |
|----------------------------|-------------|
| a. Disassembly | c. Repair |
| b. Cleaning and Inspection | d. Assembly |

*Initial Setup:***Equipment Conditions:**

- Backhoe bucket cylinder assembly removed (see TM 5-2420-222-20).

Tools/Test Equipment:

- General mechanic's tool kit
- Field automotive shop set

General Safety Instructions:

- Dry cleaning solvent is flammable and must not be used near open flame. Use only in a well-ventilated area.
- Compressed air used for cleaning purposes should never exceed 30 psi (207 kPa).

Materials/Parts:

- Abrasive cloth (Item 6, Appendix B)
- Hydraulic fluid (Item 15, Appendix B)
- Rags (Item 28, Appendix B)
- Dry cleaning solvent (Item 31, Appendix B)
- One repair kit
- One self-locking nut
- Six preformed packings (serial numbers 235786-235999)

Personnel Required: Two**a. DISASSEMBLY****NOTE****Steps 1 through 3 apply only to loader backhoes with serial numbers 235786-235999.**

1. Remove two nuts (3), compression sleeves (4), washers (5), and preformed packings (6) from adapters (7). Discard preformed packings.
2. Remove two adapters (7) and preformed packings (8) from actuating cylinder (10). Discard preformed packings.

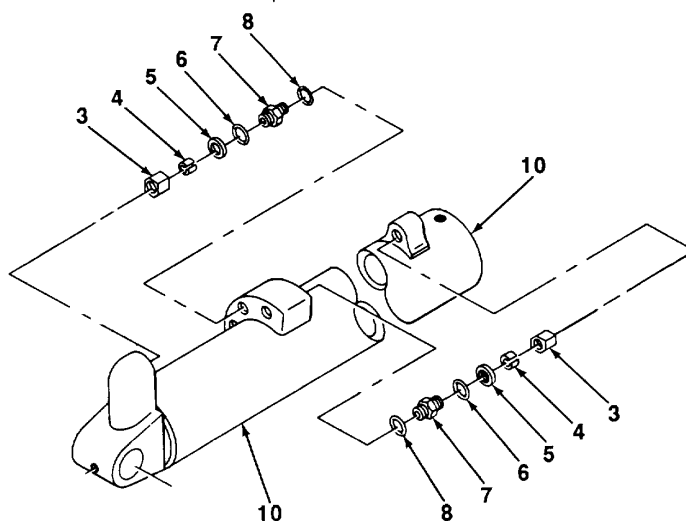

TA701615

14-21. BACKHOE BUCKET CYLINDER ASSEMBLY REPAIR.

3. Remove two return tubes (2) and preformed packings (1) from actuating cylinder (10). Discard preformed packings.
4. Place actuating cylinder (10) in vise with caps.
5. Remove setscrew (9) from actuating cylinder (10).

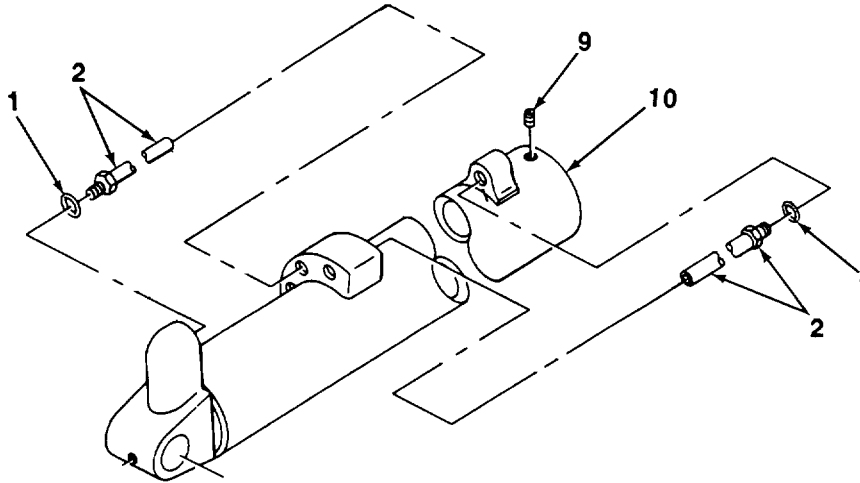

6. Using spanner wrench, loosen linear actuating cap (22) from actuating cylinder (10). Slide linear actuating cap back onto piston rod (20).

NOTE

Use a drain pan to catch fluid when draining actuating cylinder. Clean up all spills.

7. Loosen vise and tilt actuating cylinder (10) to drain hydraulic fluid.
8. Tighten vise. With the aid of an assistant, remove piston rod (20) with assembled parts from actuating cylinder (10).
9. Remove actuating cylinder (10) from vise.
10. Place piston rod (20) in vise with caps. Remove self-locking nut (12) from piston rod. Discard self-locking nut.
11. Tap piston (17) with assembled parts loose and remove from piston rod (20). Remove piston rod from vise.
12. Remove linear actuating cap (22) with assembled parts from piston rod (20).
13. Remove piston ring (13), piston ring (14), packing assembly (15), and preformed packing (16) from piston (17). Discard piston rings and preformed packing.
14. Using retaining ring pliers, remove retaining ring (27) from linear actuating cap (22).
15. Remove V-packing (26), preformed packing (25), preformed packing or packing retainer (24), wear ring (23), and wiper seal (21) from linear actuating cap (22). Discard V-packing, preformed packings, packing retainer, wear ring, and wiper seal.

14-21. BACKHOE BUCKET CYLINDER ASSEMBLY REPAIR.

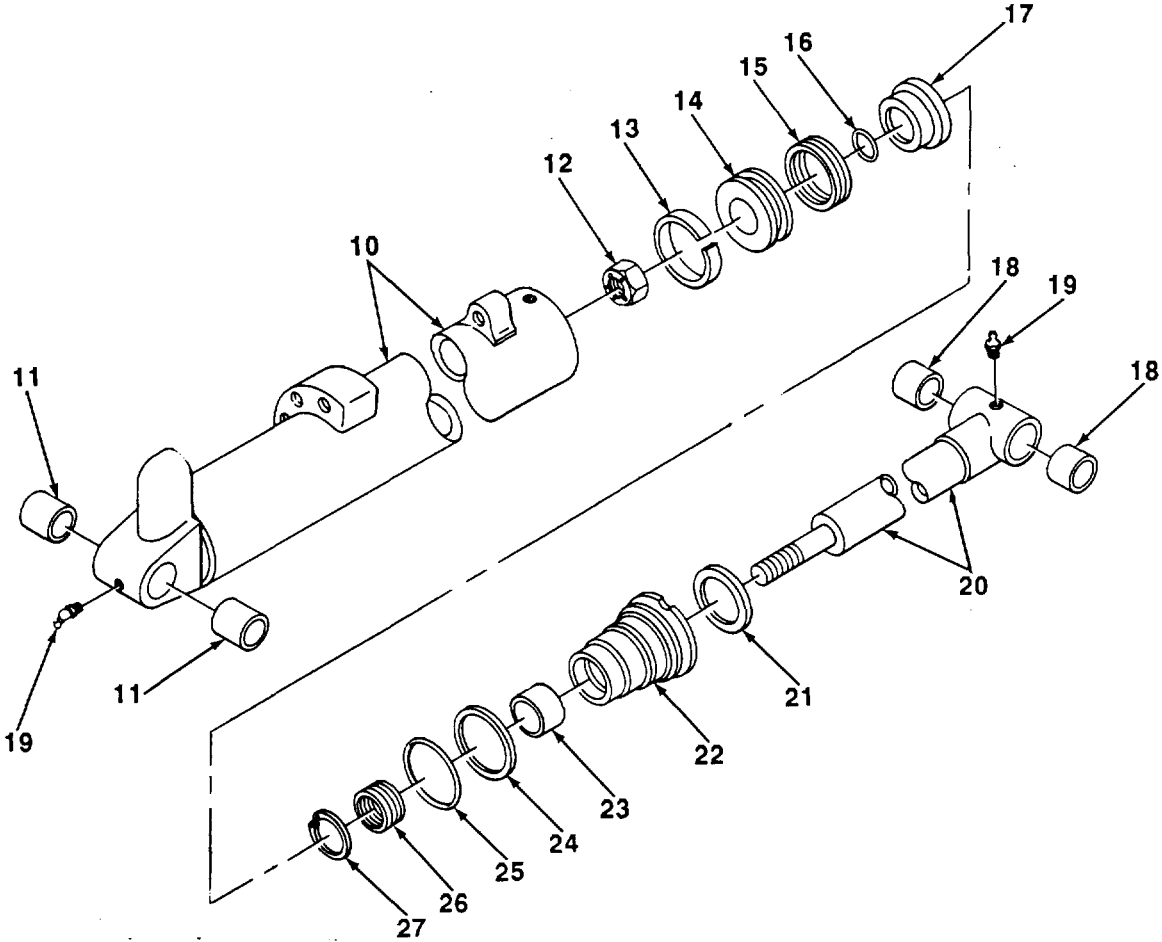

16. Remove two lubrication fittings (19) from piston rod (20) and actuating cylinder (10).

CAUTION

Do not remove sleeve bushings unless damaged. Removal may damage parts.

17. Drive sleeve bushings (11 or 18) out of actuating cylinder (10) or piston rod (20).

14-21. BACKHOE BUCKET CYLINDER ASSEMBLY REPAIR.

b. CLEANING AND INSPECTION**WARNING**

- Dry cleaning solvent, P-D-680, is toxic and flammable. Always wear protective goggles and gloves, and use only in a well-ventilated area. Avoid contact with skin, eyes, and clothes, and DO NOT breathe vapors. DO NOT use near open flame or excessive heat. The solvent's flash point is 100°F-138°F (38°C-59°C). If you become dizzy while using cleaning solvent, immediately get fresh air and medical help. If solvent contacts eyes, immediately wash your eyes and get medical aid.
- Compressed air used for cleaning or drying purposes, or for clearing restrictions, should never exceed 30 psi (207 kPa). Wear protective clothing (goggles/shield, gloves, etc.) and use caution to avoid Injury to personnel.

1. Clean all metal parts with rags dampened with dry cleaning solvent. Dry thoroughly with compressed air.
2. Inspect actuating cylinder for cracks, breaks, chips, and excessive scoring inside actuating cylinder.
3. Inspect piston rod for cracks, breaks, and excessive scoring.
4. Inspect sleeve bushings for cracks, breaks, and excessive scoring.
5. Inspect all metal parts for cracks, breaks, and abnormal bends.
6. Inspect all threaded parts for damaged threads.

c. REPAIR

1. Remove any minor scoring from actuating cylinder (10) or piston rod (20) using 600 grit abrasive cloth.
2. Restore damaged threads using pipe threading or screw threading set.

d. ASSEMBLY**NOTE**

Perform step 1 only if sleeve bushings were removed.

1. Drive sleeve bushings (11 or 18) in actuating cylinder (10) or piston rod (20).
2. Coat new V-packing (26), new preformed packing (25), new preformed packing or new packing retainer (24), new wear ring (23), and new wiper seal (21) with hydraulic fluid.
3. Install V-packing (26), preformed packing (25), preformed packing or packing retainer (24), wear ring (23), and wiper seal (21) in place on linear actuating cap (22).
4. Using retaining ring pliers, install retaining ring (27) in linear actuating cap (22).
5. Install linear actuating cap (22) with assembled parts in place on piston rod (20).
6. Coat new preformed packing (16), packing assembly (15), new piston ring (14), and new piston ring (13) with hydraulic fluid.

14-21. BACKHOE BUCKET CYLINDER ASSEMBLY REPAIR.

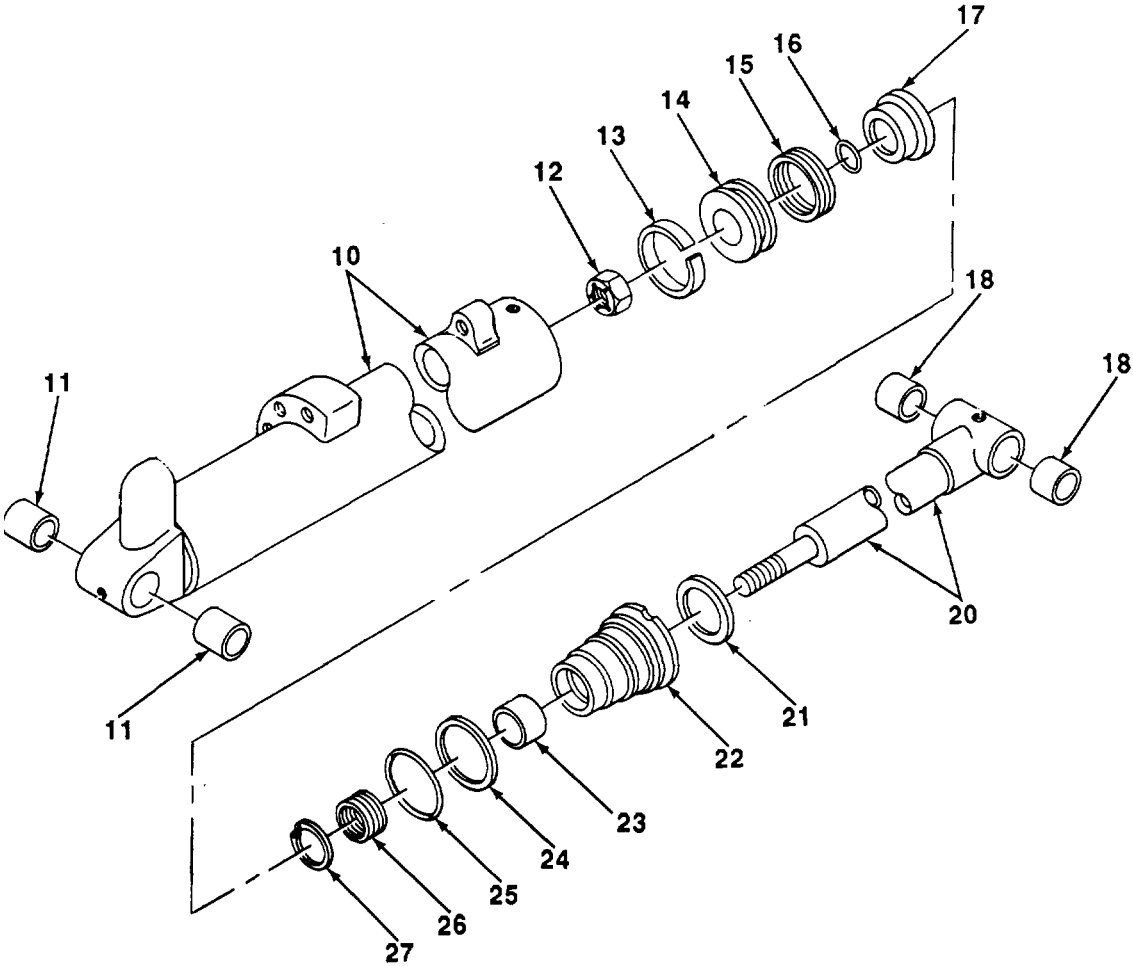

7. Install preformed packing (16), piston ring (14), piston ring (13), and packing assembly (15) in place on piston (17).
8. Place piston rod (20) in vise with caps. Tap piston (17) with assembled parts in place on piston rod.
9. Install new self-locking nut (12) on piston rod (20). Remove piston rod from vise.
10. Place actuating cylinder (10) in vise with caps. With the aid of an assistant, install piston rod (20) with assembled parts in actuating cylinder.
11. Using spanner wrench, tighten linear actuating cap (22) in actuating cylinder (10).

TA701618

14-21. BACKHOE BUCKET CYLINDER ASSEMBLY REPAIR.

12. Install setscrew (9) in actuating cylinder (10).
13. Install two lubrication fittings (19) in actuating cylinder (10) and piston rod (20).

NOTE

Steps 14 through 16 apply only to loader backhoes with serial numbers 235786-235999.

14. Install two return tubes (2) and new preformed packings (1) in actuating cylinder (10).
15. Install two adapters (7) and new preformed packings (8) in actuating cylinder (10).
16. Install two nuts (3), compression sleeves (4), washers (5), and new preformed packings (6) on adapters (7).
17. Remove actuating cylinder (10) with assembled parts from vise.

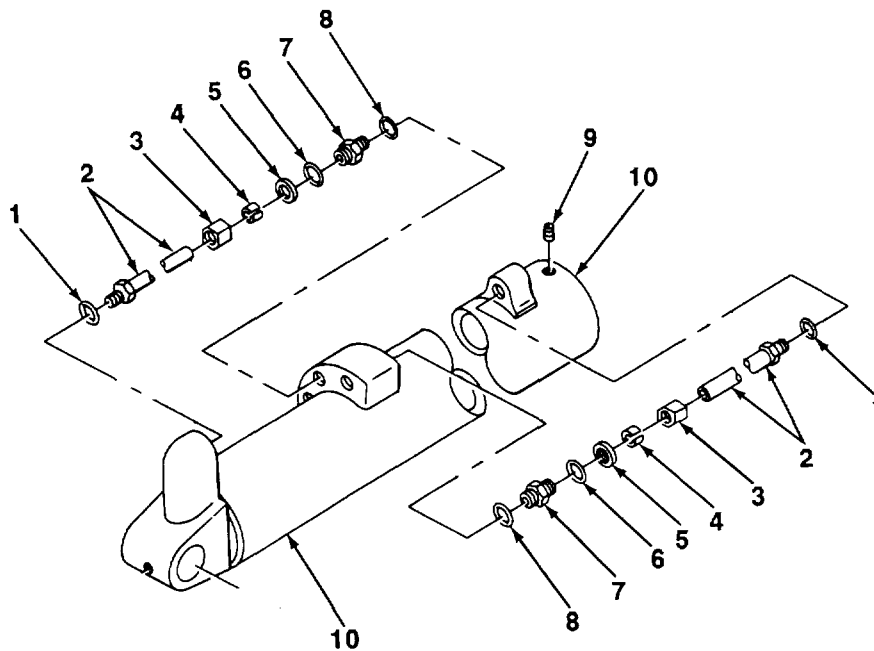

TA701619

14-21. BACKHOE BUCKET CYLINDER ASSEMBLY REPAIR.

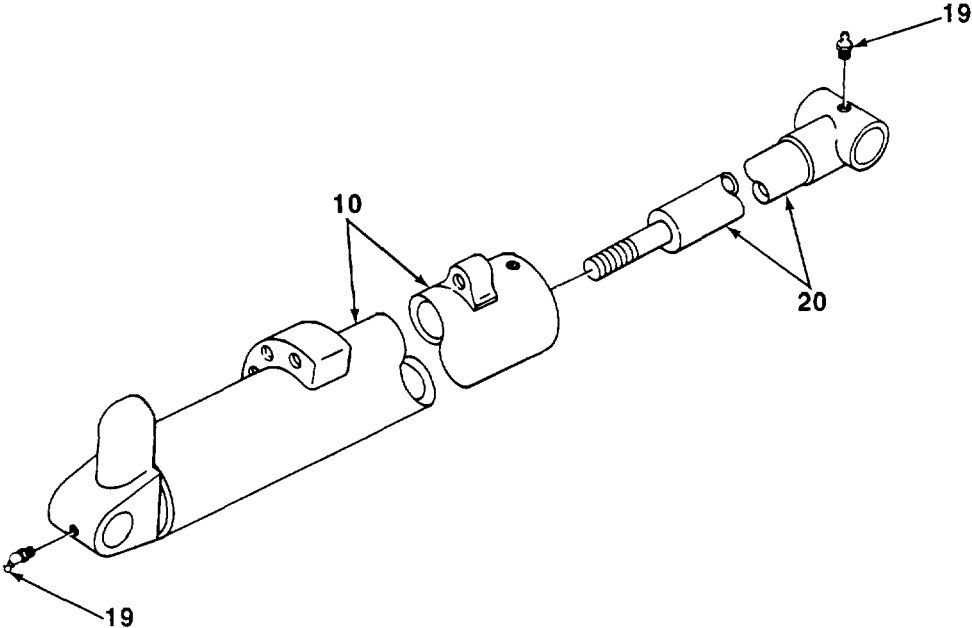

FOLLOW-ON TASKS:

- Install backhoe bucket cylinder assembly (see TM 5-2420-222-20).

TA701620

14-22. BACKHOE SWING CYLINDER ASSEMBLIES REPAIR.*This Task Covers:*

- | | |
|----------------------------|-------------|
| a. Disassembly | c. Repair |
| b. Cleaning and Inspection | d. Assembly |

*Initial Setup:***Equipment Conditions:**

- Backhoe swing cylinder assembly removed (see TM 5-2420-222-20).

Tools/Test Equipment:

- General mechanic's tool kit
- Field automotive shop set

General Safety Instructions:

- Dry cleaning solvent is flammable and must not be used near open flame. Use only in a well-ventilated area.
- Compressed air used for cleaning purposes should never exceed 30 psi (207 kPa).

Materials/Parts:

- Abrasive cloth (Item 6, Appendix B)
- Hydraulic fluid (Item 15, Appendix B)
- Rags (Item 28, Appendix B)
- Dry cleaning solvent (Item 31, Appendix B)
- One repair kit
- One seal
- One self-locking nut
- Two preformed packings

- **Personnel Required:** Two

NOTE

Perform this procedure to repair both backhoe swing cylinder assemblies. One backhoe swing cylinder assembly is shown.

a. DISASSEMBLY

1. Place actuating cylinder (5) in vise with caps.
2. Remove setscrew (4) from actuating cylinder (5).
3. Using spanner wrench, remove plug (1), backup washer (2), and preformed packing (3) from actuating cylinder (5). Discard backup wash and preformed packing.

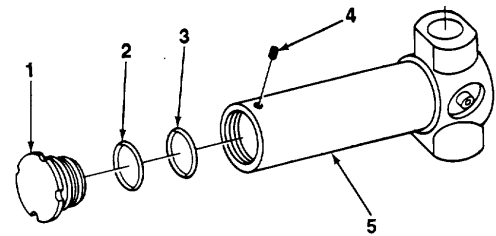
**NOTE**

Use a drain pan to catch fluid when draining actuating cylinder. Clean up all spills.

4. Loosen vise and tilt actuating cylinder (5) to drain hydraulic fluid.

TA701621

14-22. BACKHOE SWING CYLINDER ASSEMBLIES REPAIR (Con't).**NOTE**

Loader backhoes with serial numbers 235786-235999 have a spacer plate. Loader backhoes with serial numbers 319995-342573 do not have a spacer plate.

5. Tighten vise. Remove setscrew (14) and spacer plate (15) from actuating cylinder (5).
6. Using spanner wrench, loosen valve stem guide (16) from actuating cylinder (5). Slide valve stem guide back
7. With the aid of an assistant, remove piston rod (11) with assembled parts from actuating cylinder (5).
8. Remove actuating cylinder (5) from vise.
9. Place piston rod (11) in vise with caps. Remove self-locking nut (6) from piston rod. Discard self-locking nut.
10. Tap piston (8) with assembled parts loose and remove from piston rod (11). Remove piston rod from vise.
11. Remove valve stem guide (16) with assembled parts from piston rod (11).
12. Remove piston ring (7), wear ring (9), two preformed packings (23 and 24), and packing nut (22) from piston (8). Discard wear ring and preformed packings.
13. Remove preformed packing (21) and backup washer or ring (20) from valve stem guide (16). Discard preformed packing and backup washer or ring.
14. Using retaining ring pliers, remove retaining ring (19) from valve stem guide (16).

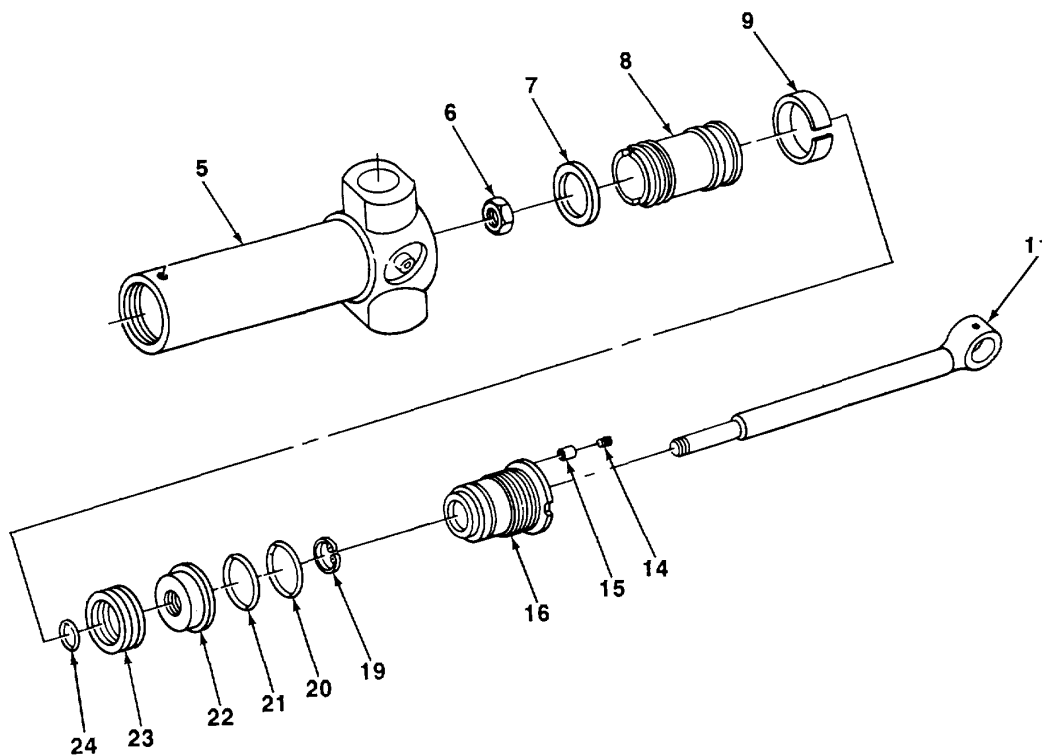

TA701622

14-22. BACKHOE SWING CYLINDER ASSEMBLIES REPAIR (Con't).

15. Remove rod packing (18), wear ring (17), and seal (13) from valve stem guide (16). Discard rod packing, wear ring, and seal.
16. Remove two lubrication fittings (10) from actuating cylinder (5).
17. Remove lubrication fitting (10) from piston rod (11).

CAUTION

Do not remove sleeve bushings unless damaged. Removal may damage parts.

18. Drive sleeve bushing (12 or 25) out of piston rod (11) or actuating cylinder (5).

b. CLEANING AND INSPECTION**WARNING**

- **Dry cleaning solvent, P-D-680, is toxic and flammable. Always wear protective goggles and gloves, and use only in a well-ventilated area. Avoid contact with skin, eyes, and clothes, and DO NOT breathe vapors. DO NOT use near open flame or excessive heat. The solvent's flash point is 100°F-138°F (38°C-59°C). If you become dizzy while using cleaning solvent, immediately get fresh air and medical help. If solvent contacts eyes, immediately wash your eyes and get medical aid.**
- **Compressed air used for cleaning or drying purposes, or for clearing restrictions, should never exceed 30 psi (207 kPa). Wear protective clothing (goggles/shield, gloves, etc.) and use caution to avoid injury to personnel.**

1. Clean all metal parts with rags dampened with dry cleaning solvent. Dry thoroughly with compressed air.
2. Inspect actuating cylinder for cracks, breaks, chips, and excessive scoring inside actuating cylinder.
3. Inspect piston rod for cracks, breaks, and excessive scoring.
4. Inspect sleeve bushings for cracks, breaks, and excessive scoring.
5. Inspect all metal parts for cracks, breaks, and abnormal bends.
6. Inspect all threaded parts for damaged threads.

c. REPAIR

1. Remove any minor scoring from actuating cylinder (5) or piston rod (11) using 600 grit abrasive cloth.
2. Restore damaged threads using pipe threading or screw threading set.

d. ASSEMBLY**NOTE**

Perform step 1 only if sleeve bushings were removed.

1. Drive sleeve bushing (12 or 25) in piston rod (11) or actuating cylinder (5).

14-22. BACKHOE SWING CYLINDER ASSEMBLIES REPAIR (Con't).

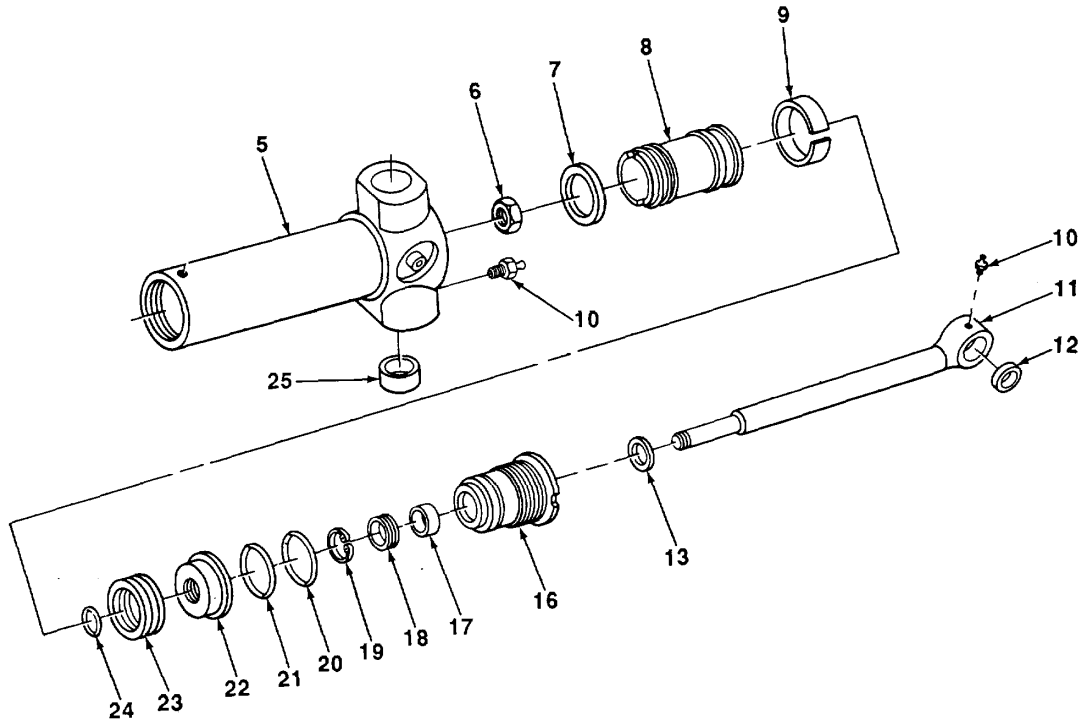

2. Coat new rod packing (18), new wear ring (17), new preformed packing (21), new backup washer or ring (2), and new seal (13) with hydraulic fluid.
3. Install rod packing (18), wear ring (17), preformed packing (21), backup washer or ring (20), and seal (13) in place on valve stem guide (16).
4. Using retaining ring pliers, install retaining ring (19) in valve stem guide (16).
5. Install valve stem guide (16) with assembled parts in place on piston rod (11).
6. Coat new preformed packings (23 and 24), packing nut (22), new wear ring (9), and piston ring (7) with hydraulic fluid.
7. Install preformed packings (23 and 24), packing nut (22), wear ring (9), and piston ring (7) in place on piston (8).
8. Place piston rod (11) in vise with caps. Tap piston (8) with assembled parts in place on piston rod.
9. Install new self-locking nut (6) on piston rod (11) and remove piston rod from vise.
10. Place actuating cylinder (5) in vise with caps. With the aid of an assistant, install piston rod (11) with assembled parts in actuating cylinder.
11. Using spanner wrench, tighten valve stem guide (16) in actuating cylinder (5).
12. Install two lubrication fittings (10) in actuating cylinder (5). Install lubrication fitting in piston rod (11).

TA701623

14-22. BACKHOE SWING CYLINDER ASSEMBLIES REPAIR (Con't).**NOTE**

Loader backhoes with serial numbers 235786-235999 have a spacer plate. Loader backhoes with serial numbers 319995-342573 do not have a spacer plate.

13. Install setscrew (14) and spacer plate (15) in actuating cylinder (5) to secure valve stem guide (16).

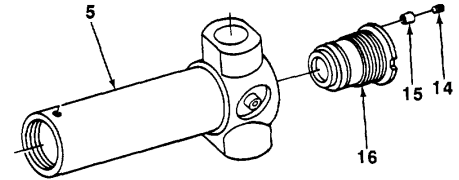

14. Install plug (1), new backup washer (2), and new preformed packing (3) in actuating cylinder (5).

15. Install setscrew (4) in actuating cylinder (5) to secure plug (1).

16. Remove actuating cylinder (5) with assembled parts from vise.

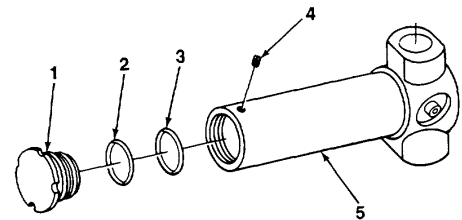
**FOLLOW-ON TASKS:**

- Install backhoe swing cylinder assembly (see TM 5-2420-222-20).

TA701624

14-23. BACKHOE STABILIZER CYLINDER ASSEMBLIES REPAIR.*This Task Covers:*

- | | |
|----------------------------|-------------|
| a. Disassembly | c. Repair |
| b. Cleaning and Inspection | d. Assembly |

*Initial Setup:***Equipment Conditions:**

- Backhoe stabilizer cylinder assembly removed (see TM 5-2420-222-20).

Tools/Test Equipment:

- General mechanic's tool kit
- Field automotive shop set

Materials/Parts:

- Abrasive cloth (Item 6, Appendix B)
- Hydraulic fluid (Item 15, Appendix B)
- Rags (Item 28, Appendix B)
 - Dry cleaning solvent (Item 31, Appendix B)
- One repair kit
- One self-locking nut

Personnel Required: Two**General Safety Instructions:**

- Dry cleaning solvent is flammable and must not be used near open flame. Use only in a well-ventilated area.
- Compressed air used for cleaning purposes should never exceed 30 psi (207 kPa).

NOTE

Perform this procedure to repair both backhoe stabilizer cylinder assemblies. One backhoe stabilizer cylinder assembly is shown.

a. DISASSEMBLY

1. Place actuating cylinder 91) in vise with caps.

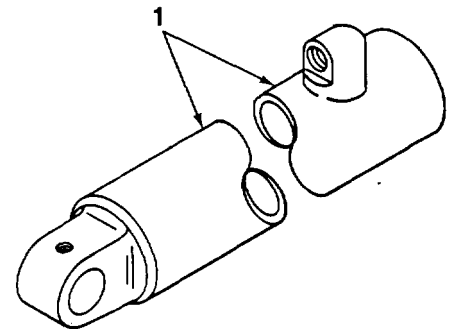

TA701625

14-23. BACKHOE STABILIZER CYLINDER ASSEMBLIES REPAIR (Cont).

2. Using spanner wrench, loosen nut (11) from actuating cylinder (1). Slide nut back onto piston rod (10).

NOTE

Use a drain pan to catch fluid when draining actuating cylinder. Clean up all spills.

- 3. Loosen vise and tilt actuating cylinder (1) to drain hydraulic fluid.
- 4. Tighten vise. With the aid of an assistant, remove piston rod (10) with assembled parts from actuating cylinder (1).
- 5. Remove actuating cylinder (1) from vise.
- 6. Place piston rod (10) in vise with caps. Remove self-locking nut (2) from piston rod. Discard self-locking nut.
- 7. Tap pistons (4 and 7) with assembled parts loose and remove from piston rod (10). Remove piston rod from vise.
- 8. Remove rod guide (16) with assembled parts, cylinder roller bearing (13), and nut (11) from piston rod (10).
- 9. Remove piston ring (3) from piston (4). Discard piston ring.

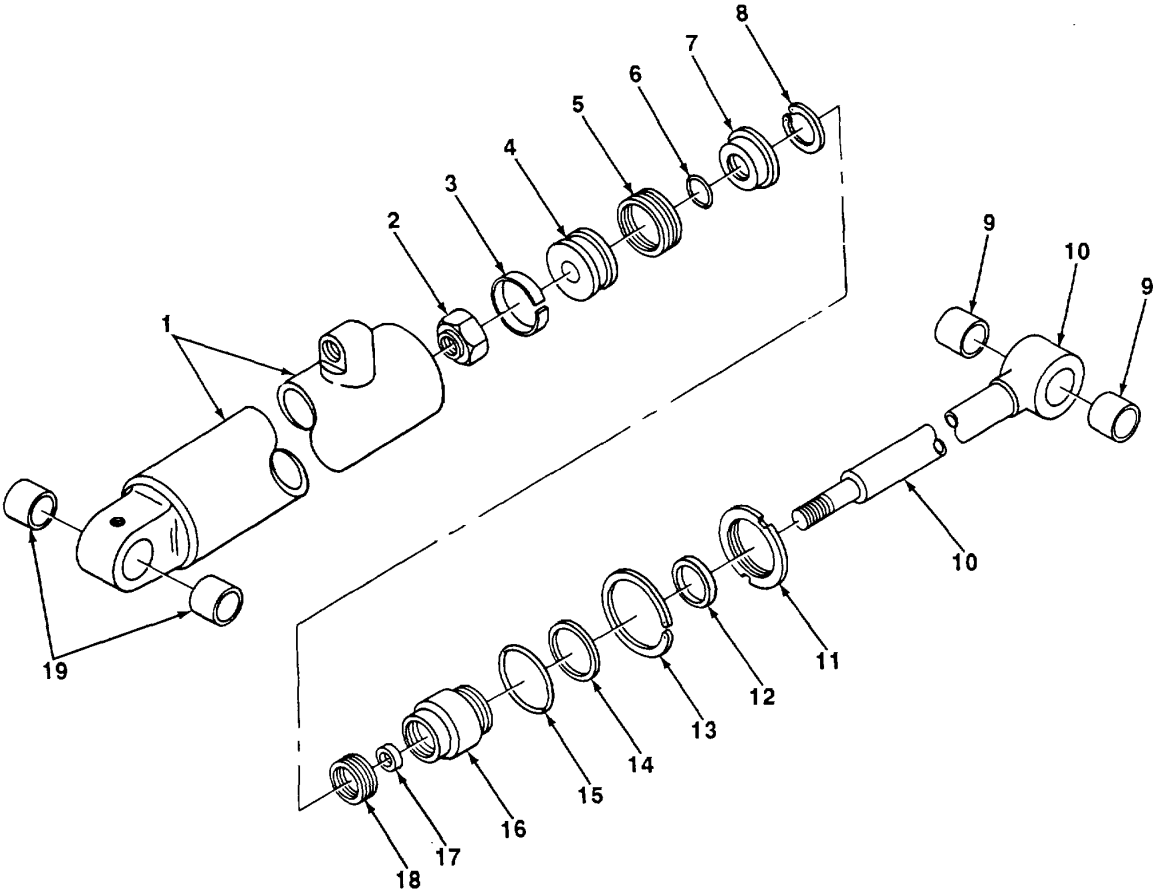

14-23. BACKHOE STABILIZER CYLINDER ASSEMBLIES REPAIR (Con't).

13. Remove packing assembly (5) and preformed packing (6) from piston (7). Discard packing assembly and preformed packing.
11. Using retaining ring pliers, remove retaining ring (8) from rod guide (16).
12. Remove rod packing (18), wear ring (17), two preformed packings (14 and 15), and wiper seal (12) from rod guide (16). Discard rod packing, wear ring, preformed packings, and wiper seal.

CAUTION

Do not remove sleeve bushings unless damaged. Removal may damage parts.

13. Drive sleeve bushings (9 or 19) out of piston rod (10) or actuating cylinder (1).

b. CLEANING AND INSPECTION**WARNING**

- **Dry cleaning solvent, P-D-680, is toxic and flammable. Always wear protective goggles and gloves, and use only in a well-ventilated area. Avoid contact with skin, eyes, and clothes, and DO NOT breathe vapors. DO NOT use near open flame or excessive heat. The solvent's flash point is 100°F-138°F (38°C-59°C). If you become dizzy while using cleaning solvent, immediately get fresh air and medical help. If solvent contacts eyes, immediately wash your eyes and get medical aid.**
- **Compressed air used for cleaning or drying purposes, or for clearing restrictions, should never exceed 30 psi (207 kPa). Wear protective clothing (goggles/shield, gloves, etc.) and use caution to avoid injury to personnel.**

1. Clean all metal parts with rags dampened with dry cleaning solvent. Dry thoroughly with compressed air.
2. Inspect actuating cylinder for cracks, breaks, chips, and excessive scoring inside actuating cylinder.
3. Inspect piston rod for cracks, breaks, and excessive scoring.
4. Inspect sleeve bushings for cracks, breaks, and excessive scoring.
5. Inspect all metal parts for cracks, breaks, and abnormal bends.
6. Inspect all threaded parts for damaged threads.

c. REPAIR

1. Remove any minor scoring from actuating cylinder (5) or piston rod (11) using 600 grit abrasive cloth.
2. Restore damaged threads using pipe threading or screw threading set.

14-23. BACKHOE STABILIZER CYLINDER ASSEMBLIES REPAIR (Con't).

d. ASSEMBLY**NOTE**

Perform step 1 only if sleeve bushings were removed.

1. Drive sleeve bushings (9 or 19) in piston rod (10) or actuating cylinder (1).
2. Coat new rod packing (18), new wear ring (17), two new preformed packings (14 and 15), and new wiper seal (12) with hydraulic fluid.
3. Install rod packing (18), wear ring (17), two preformed packings (14 and 15), and wiper seal (12) in place on rod guide (16).
4. Using retaining ring pliers, install retaining ring (8) in rod guide (16).
5. Install nut (11), cylinder roller bearing (13), and rod guide (16) with assembled parts in place on piston rod (1).
6. Coat new preformed packing (6) and new packing assembly (5) with hydraulic fluid.
7. Install preformed packing (6) and packing assembly (5) in place on piston (7).
8. Place piston rod (10) in vise with caps. Tap piston (7) with assembled parts in place on piston rod.
9. Coat new piston ring (3) with hydraulic fluid.
10. Install piston ring (3) in place on piston (4). Tap piston with assembled parts in place on piston rod (10).
11. Install new self-locking nut (2) on piston rod (10) and remove piston rod from vise.
12. Place actuating cylinder (1) in vise with caps. With the aid of an assistant, install piston rod (10) with assembled parts in actuating cylinder.
13. Using spanner wrench, tighten nut (11) in actuating cylinder (1).
14. Remove actuating cylinder (1) with assembled parts from vise.

14-23. BACKHOE STABILIZER CYLINDER ASSEMBLIES REPAIR (Con't).

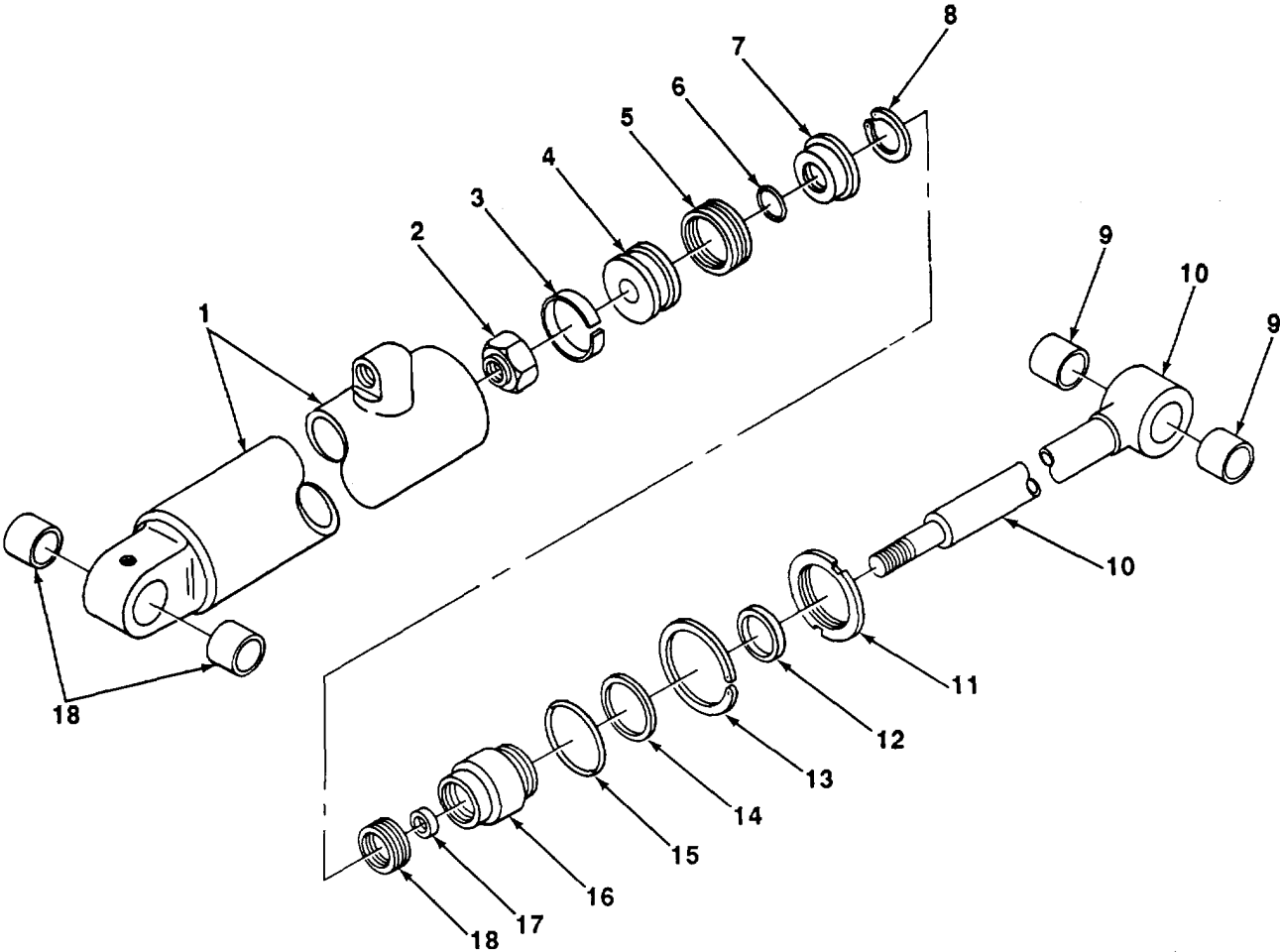

FOLLOW-ON TASKS:

- Install backhoe stabilizer cylinder assembly (see TM 5-2420-222-20).

14-24. LOADER BUCKET CYLINDER ASSEMBLIES REPAIR.*This Task Covers:*

- | | |
|----------------------------|-------------|
| a. Disassembly | c. Repair |
| b. Cleaning and Inspection | d. Assembly |

*Initial Setup:***Equipment Conditions:**

- Loader bucket cylinder assembly removed (see TM 5-2420-222-20).

Tools/Test Equipment:

- General mechanic's tool kit
- Field automotive shop set

Materials/Parts:

- Abrasive cloth (Item 6, Appendix B)
- Hydraulic fluid (Item 15, Appendix B)
- Rags (Item 28, Appendix B)
- Dry cleaning solvent (Item 31, Appendix B)
- One repair kit
- One self-locking nut

General Safety Instructions:

- Dry cleaning solvent is flammable and must not be used near open flame. Use only in a well-ventilated area.
- Compressed air used for cleaning purposes should never exceed 30 psi (207 kPa).

Personnel Required: Two**NOTE**

Perform this procedure to repair both loader bucket cylinder assemblies. One loader bucket cylinder assembly is shown.

a. DISASSEMBLY

1. Place cylinder (1) in vise with caps.
2. Using spanner wrench, loosen nut (10) from cylinder (1). Slide nut back onto piston rod (9).

NOTE

Use a drain pan to catch fluid when draining cylinder. Clean up all spills.

3. Loosen vise and tilt cylinder (1) to drain hydraulic fluid.
4. Tighten vise. With the aid of an assistant, remove piston rod (9) with assembled parts from cylinder (1).
5. Remove cylinder (1) from vise.
6. Place piston rod (9) in vise with caps. Remove self-locking nut (2) from piston rod. Discard self-locking nut.
7. Tap pistons (4 and 7) with assembled parts loose and remove from piston rod (9). Remove piston rod from vise.
8. Remove rod guide (15) with assembled parts, retaining ring (12), and nut (10) from piston rod (9).
9. Remove wear ring (3) from piston (4). Discard wear ring.
10. Remove V-packing (5) and preformed packing (6) from piston (7). Discard V-packing and preformed packing.
11. Using retaining ring pliers, remove retaining ring (18) from rod guide (15).
12. Remove V-packing (17), wear ring (16), preformed packing (14), backup washer (13), and seal (11) from rod guide (15). Discard V-packing, wear ring, preformed packing, backup washer, and seal.

14-24. LOADER BUCKET CYLINDER ASSEMBLIES REPAIR (Con't).

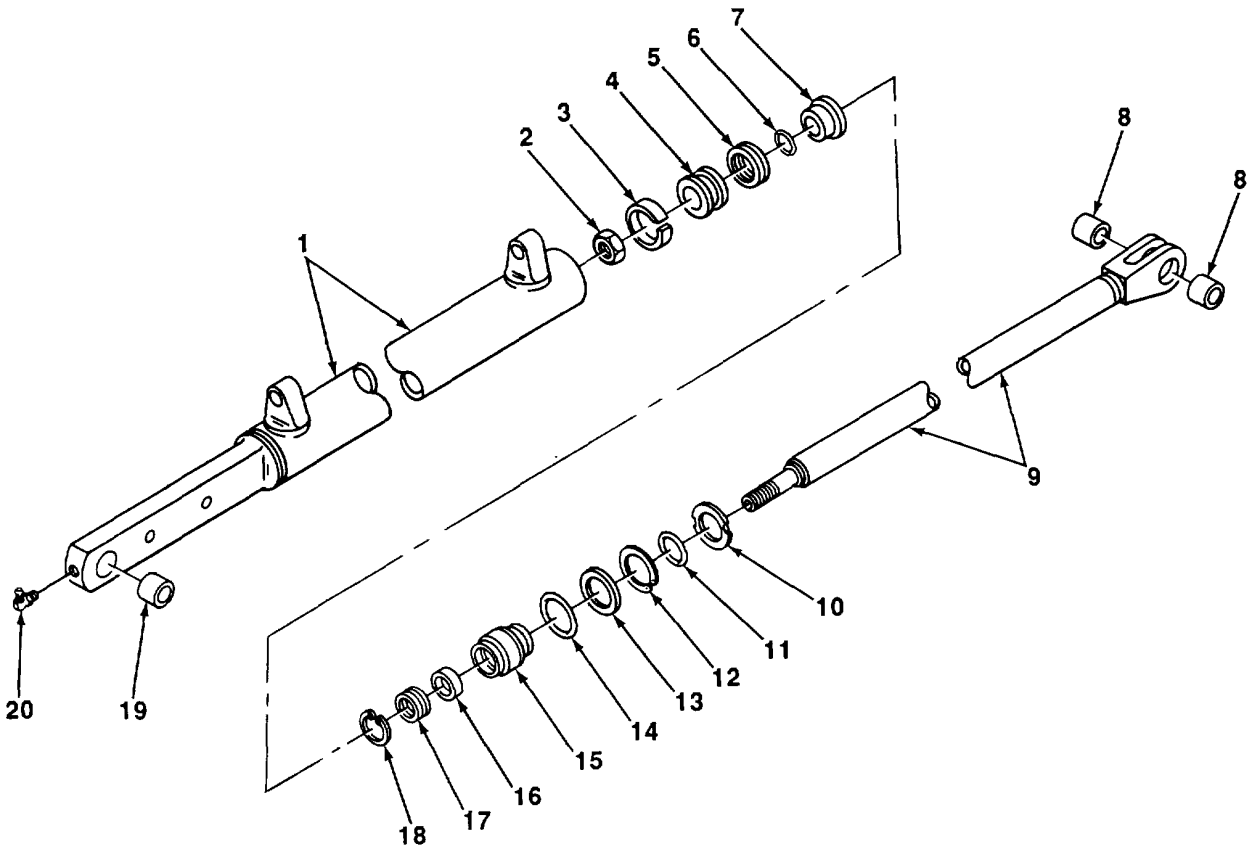

CAUTION

Do not remove sleeve bushings unless damaged. Removal may damage parts.

- 13. Drive sleeve bushings (8 or 19) out of piston rod (9) or cylinder (1).
- 14. Remove lubrication fitting (20) from cylinder (1).

TA701628

14-24. LOADER BUCKET CYLINDER ASSEMBLIES REPAIR (Con't).

b. CLEANING AND INSPECTION**WARNING**

- Dry cleaning solvent, P-D-680, is toxic and flammable. Always wear protective goggles and gloves, and use only in a well-ventilated area. Avoid contact with skin, eyes, and clothes, and DO NOT breathe vapors. DO NOT use near open flame or excessive heat. The solvent's flash point is 100°F-138°F (38°C-59°C). If you become dizzy while using cleaning solvent, immediately get fresh air and medical help. If solvent contacts eyes, immediately wash your eyes and get medical aid.
- Compressed air used for cleaning or drying purposes, or for clearing restrictions, should never exceed 30 psi (207 kPa). Wear protective clothing (goggles/shield, gloves, etc.) and use caution to avoid injury to personnel.

1. Clean all metal parts with rags dampened with dry cleaning solvent. Dry thoroughly with compressed air.
2. Inspect cylinder for cracks, breaks, chips, and excessive scoring inside cylinder.
3. Inspect piston rod for cracks, breaks, and excessive scoring.
4. Inspect sleeve bushings for cracks, breaks, and excessive scoring.
5. Inspect all metal parts for cracks, breaks, and abnormal bends.
6. Inspect all threaded parts for damaged threads.

d. REPAIR

1. Remove any minor scoring from cylinder (1) or piston rod (9) using 600 grit abrasive cloth.
2. Restore damaged threads using pipe threading or screw threading set.

d. ASSEMBLY**NOTE**

Perform step 1 only if sleeve bushings were removed.

1. Drive sleeve bushings (8 or 19) in piston rod (9) or cylinder (1).
2. Coat new V-packing (17), new wear ring (16), new preformed packing (14), new backup washer (13), and new seal (11) with hydraulic fluid.
3. Install V-packing (17), wear ring (16), preformed packing (14), backup washer (13), and seal (11) in place on rod guide (15).
4. Using retaining ring pliers, install retaining ring (18) in rod guide (15).
5. Install nut (10), retaining ring (12), and rod guide (15) with assembled parts in place on piston rod (9).
6. Coat new preformed packing (6) and new V-packing (5) with hydraulic fluid.
7. Install preformed packing (6) and V-packing (5) in place on piston (7).

14-24. LOADER BUCKET CYLINDER ASSEMBLIES REPAIR (Con't).

8. Place piston rod (9) in vise with caps. Tap piston (7) with assembled parts in place on piston rod.
9. Coat new wear ring (3) with hydraulic fluid.
10. Install wear ring (3) in place on piston (4). Tap piston with assembled parts in place on piston rod (9).
11. Install new self-locking nut (2) on piston rod (9) and remove piston rod from vise.
12. Place cylinder (1) in vise with caps. With the aid of an assistant, install piston rod (9) with assembled parts in cylinder.
13. Using spanner wrench, tighten nut (10) in cylinder (1).
14. Install lubrication fitting (20) in cylinder (1). Remove cylinder from vise.

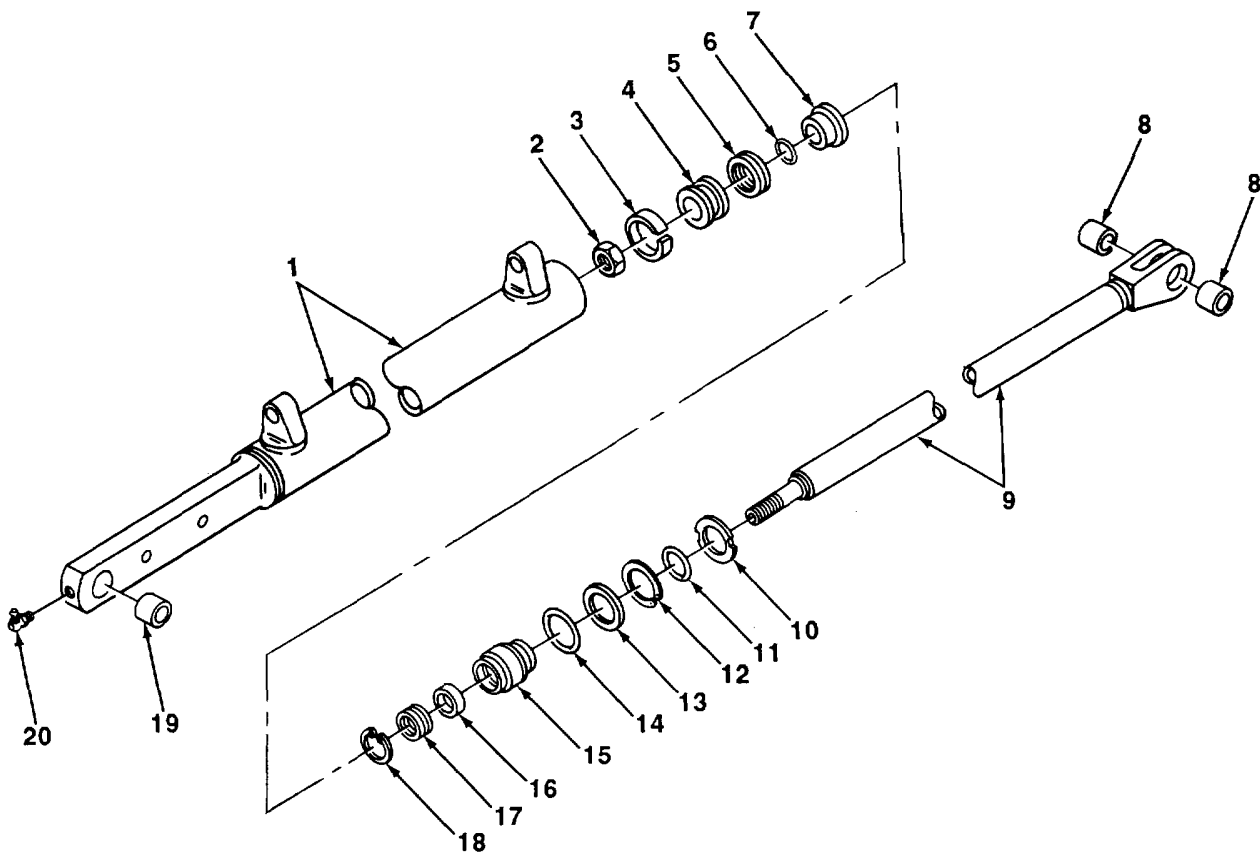
**FOLLOW-ON TASKS:**

- Install loader bucket cylinder assembly (see TM 5-2420-222-20).

14-25. LOADER BOOM CYLINDER ASSEMBLIES REPAIR.*This Task Covers:*

- | | |
|----------------------------|-------------|
| a. Disassembly | c. Repair |
| b. Cleaning and Inspection | d. Assembly |

*Initial Setup:***Equipment Conditions:**

- Loader boom cylinder assembly removed(see TM 5-2420-222-20).

Tools/Test Equipment:

- General mechanic's tool kit
- Field automotive shop set

Materials/Parts:

- Abrasive cloth (Item 6, Appendix B)
- Hydraulic fluid (Item 15, Appendix B)
- Rags (Item 28, Appendix B)
- Dry cleaning solvent (Item 31, Appendix B)
- Rags (Item 28, Appendix B)
- One repair kit
- One self-locking nut

Personnel Required: Two**General Safety Instructions:**

- Dry cleaning solvent is flammable and must not be used near open flame. Use only in a well-ventilated area.
- Compressed air used for cleaning purposes should never exceed 30 psi (207 kPa).

NOTE

Perform this procedure to repair both loader boom cylinder assemblies. One loader boom cylinder assembly is shown.

a. DISASSEMBLY

1. Place cylinder (2) in vise with caps.
2. Using spanner wrench, loosen nut (12) from cylinder (2). Slide nut back onto piston rod (10).

NOTE

Use a drain pan to catch fluid when draining cylinder. Clean up all spills.

3. Loosen vise and tilt cylinder (2) to drain hydraulic fluid.
4. Tighten vise. With the aid of an assistant, remove piston rod (10) with assembled parts from cylinder (2).
5. Remove cylinder (2) from vise.
6. Place piston rod (10) in vise with caps. Remove self-locking nut (3) from piston rod. Discard self-locking nut.
7. Tap pistons (5 and 8) with assembled parts loose and remove from piston rod (10). Remove piston rod from vise.
8. Remove alining rod (17) with assembled parts and nut (12) from piston rod (10).
9. Remove bearing ring (4) from piston (5). Discard bearing ring.
10. Remove V-packing (6) and preformed packing (7) from piston (8). Discard V-packing and preformed packing.
11. Using retaining ring pliers, remove retaining ring (20) from alining rod (17).

14-25. LOADER BOOM CYLINDER ASSEMBLIES REPAIR (Con't).

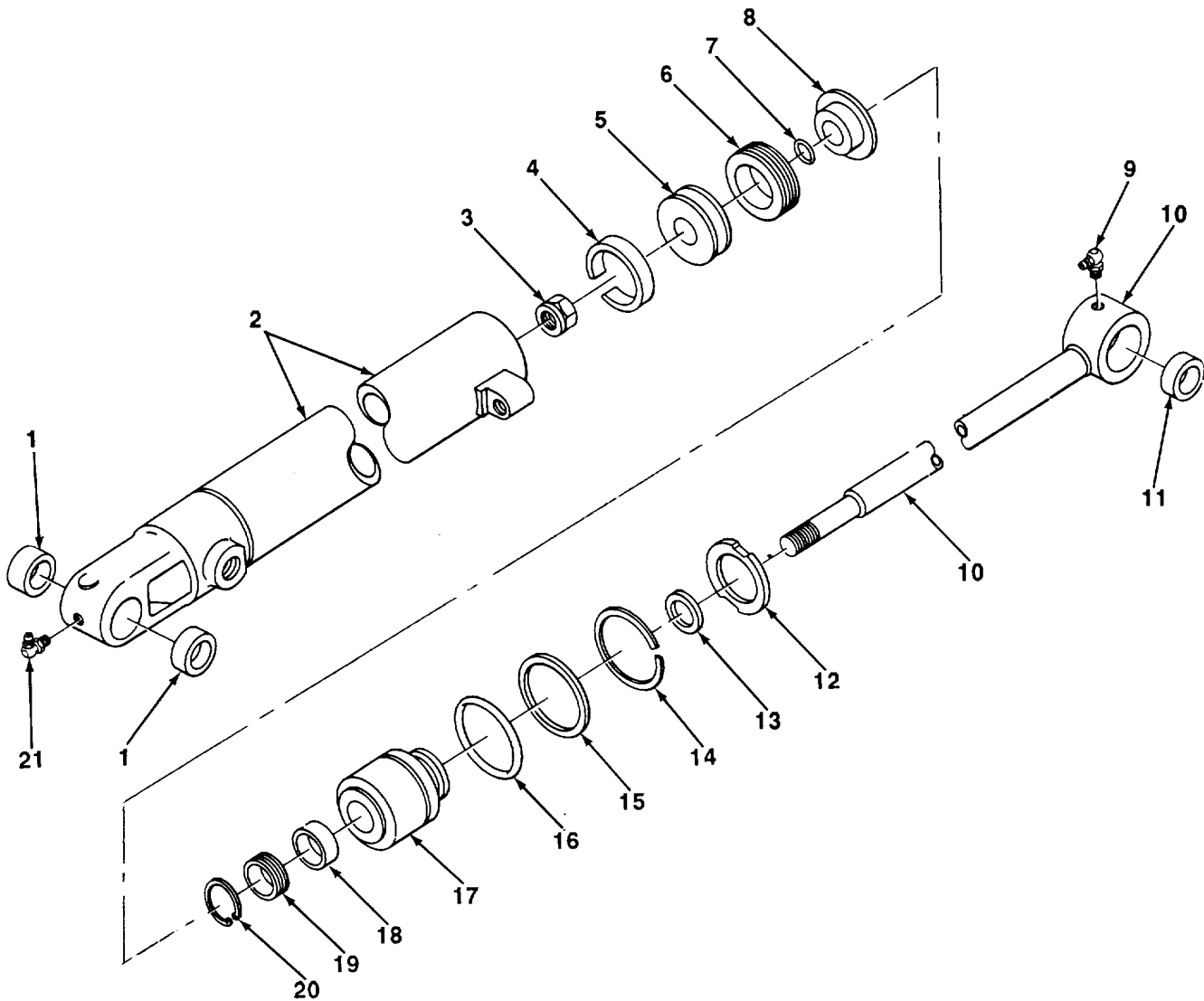

12. Remove rod packing (19), wear ring (18), preformed packing (16), backup washer (15), retaining ring (14), and seal (13) from aligning rod (17). Discard rod packing, wear ring, preformed packing, backup washer, and seal.

CAUTION

Do not remove sleeve bushings unless damaged. Removal may damage parts.

13. Drive sleeve bushings (11 or 1) out of piston rod (10) or cylinder (2).
14. Remove lubrication fittings (9 and 21) from piston rod (10) and cylinder (2).

14-25. LOADER BOOM CYLINDER ASSEMBLIES REPAIR (Con't).

b. CLEANING AND INSPECTION**WARNING**

- Dry cleaning solvent, P-D-680, is toxic and flammable. Always wear protective goggles and gloves, and use only in a well-ventilated area. Avoid contact with skin, eyes, and clothes, and DO NOT breathe vapors. DO NOT use near open flame or excessive heat. The solvent's flash point is 100°F-138°F (38°C-59°C). If you become dizzy while using cleaning solvent, immediately get fresh air and medical help. If solvent contacts eyes, immediately wash your eyes and get medical aid.
- Compressed air used for cleaning or drying purposes, or for clearing restrictions, should never exceed 30 psi (207 kPa). Wear protective clothing (goggles/shield, gloves, etc.) and use caution to avoid injury to personnel.

1. Clean all metal parts with rags dampened with dry cleaning solvent. Dry thoroughly with compressed air.
2. Inspect cylinder for cracks, breaks, chips, and excessive scoring inside cylinder.
3. Inspect piston rod for cracks, breaks, and excessive scoring.
4. Inspect sleeve bushings for cracks, breaks, and excessive scoring.
5. Inspect all metal parts for cracks, breaks, and abnormal bends.
6. Inspect all threaded parts for damaged threads.

c. REPAIR

1. Remove any minor scoring from actuating cylinder (2) or piston rod (10) using 600 grit abrasive cloth.
2. Restore damaged threads using pipe threading or screw threading set.

d. ASSEMBLY**NOTE**

Perform step 1 only if sleeve bushings were removed.

1. Drive sleeve bushings (11 or 1) in piston rod (10) or cylinder (2).
2. Coat new rod packing (19), new wear ring (18), new preformed packing (16), new backup washer (15) and new
3. Install rod packing (19), wear ring (18), preformed packing (16), backup washer (15), seal (13), and retaining ring (14) in place on alining rod (17).
4. Using retaining ring pliers, install retaining ring (20) in alining rod (17).
5. Install nut (12) and alining rod (17) with assembled parts in place on piston rod (10).
6. Coat new preformed packing (7) and new V-packing (6) with hydraulic fluid.
7. Install preformed packing (7) and V-packing (6) in place on piston (8).
8. Place piston rod (10) in vise with caps. Tap piston (8) with assembled parts in place on piston rod.

14-25. LOADER BOOM CYLINDER ASSEMBLIES REPAIR (Con't)

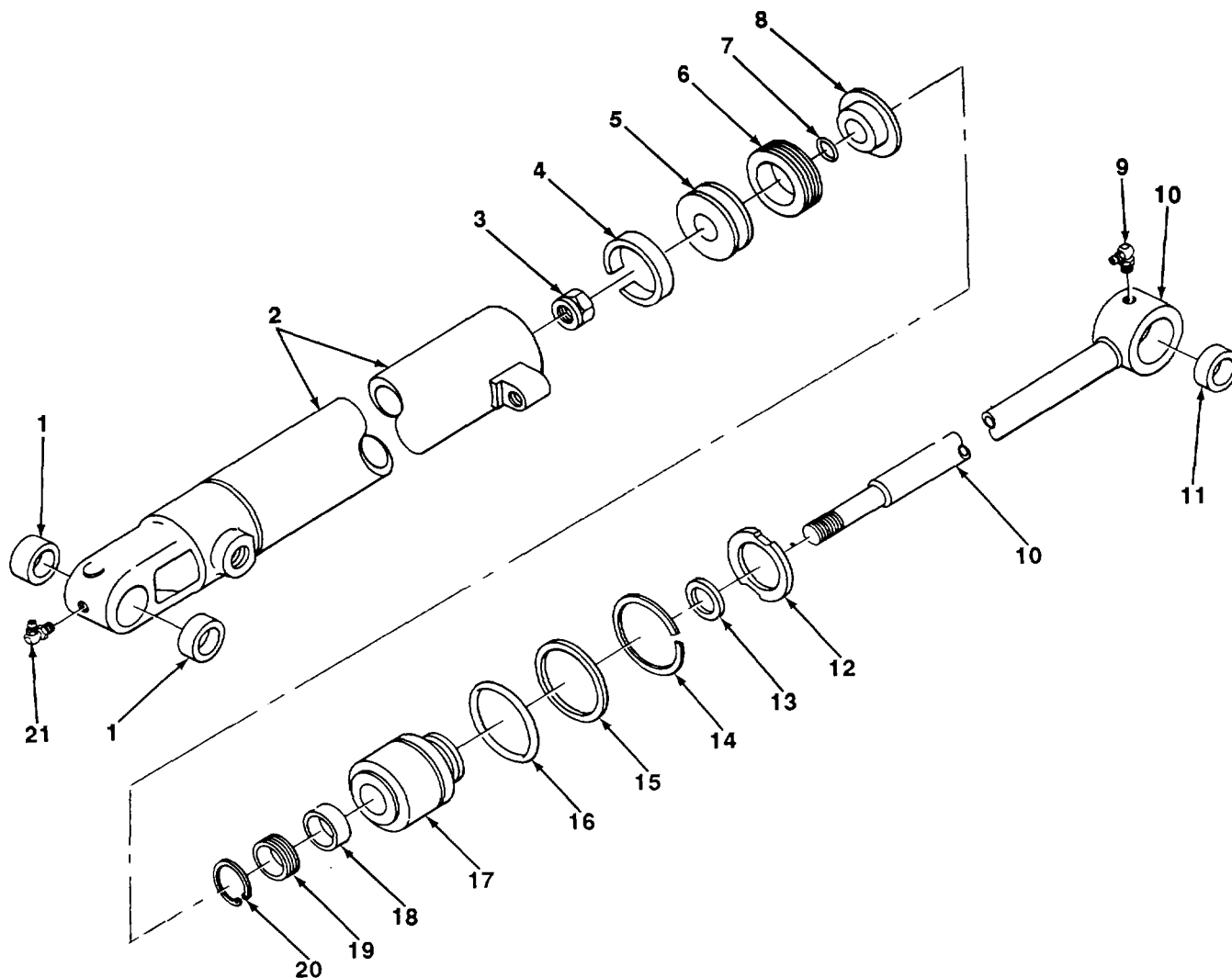

9. Coat new bearing ring (4) with hydraulic fluid.
10. Install bearing ring (4) in place on piston (5). Tap piston with assembled parts in place on piston rod (10).
11. Install new self-locking nut (3) on piston rod (10) and remove piston rod from vise.
12. Place cylinder (2) in vise with caps. With the aid of an assistant, install piston rod (10) with assembled parts in cylinder.
13. Using spanner wrench, tighten nut (12) in cylinder (2).
14. Install lubrication fittings (9 and 21) in piston rod (10) and cylinder (2). Remove cylinder from vise.

FOLLOW-ON TASKS:

- Install loader boom cylinder assembly (see TM 5-2420-222-20).

TA701631

**CHAPTER 15
CRANES, SHOVELS, AND EARTHMOVING EQUIPMENT
COMPONENTS MAINTENANCE**

Section I. BACKHOE ASSEMBLY MAINTENANCE

Paragraph Number	Paragraph Title	Page Number
15-1	Backhoe Dipperstick Maintenance	15-1
15-2	Backhoe Boom Maintenance	15-8
15-3	Backhoe Swing Frame Maintenance.....	15-11
15-4	Backhoe Main Frame Maintenance	15-17

15-1. BACKHOE DIPPERSTICK MAINTENANCE.

This Task Covers:

- | | |
|--|---|
| <ul style="list-style-type: none"> a. Removal b. Disassembly c. Cleaning and Inspection | <ul style="list-style-type: none"> d. Repair e. Assembly f. Installation |
|--|---|

Initial Setup:

Tools/Test Equipment:

- General mechanic's tool kit
- Field automotive shop set

References:

- TM 5-2420-222-10
- TM 5-2420-222-10

Personnel Required: Two

Materials/Parts:

- Rags (Item 28, Appendix B)
- Dry cleaning solvent (Item 31, Appendix B)
- One grease fitting
- Two cotter pins (serial numbers 235786-235999)

General Safety Instructions:

- Dry cleaning solvent is flammable and must not be used near open flame. Use only in a well-ventilated area.

a. REMOVAL

1. Extend and lower backhoe boom, dipperstick, and bucket parallel to ground and support on wood blocks (see TM 5-2420-222-10).
2. Shut down engine assembly (see TM 5-2420-222-10).
3. Remove manifold block-to-jaw cylinder oil hose oil line (see TM 5-2420-222-20).
4. Remove backhoe control valve-to-female quick coupler oil lines (see TM 5-2420-222-20).
5. Remove hydraulic impactor flow regulator-to-nipple quick coupler oil lines (see TM 5-2420-222-20).

15-1. BACKHOE DIPPERSTICK MAINTENANCE (Con't).

6. Remove screw (4) and nut (6) from dipperstick (2) and pin (5).
7. Drive pin (5) out of dipperstick (2) and crowd cylinder (1) with brass driftpin and ball-peen hammer.
8. Place wood blocks between crowd cylinder (1) and boom (9).
9. Remove screw (3) and nut (7) from dipperstick (2) and pin (8).
10. Drive pin (8) out of dipperstick (2) and boom (9).

WARNING

Use extreme caution when handling heavy parts. Lifting device is required when parts weigh over 50 lb. (23 kg) for a single person lift, over 100 lb (45 kg) for a two person lift, and over 150 lb. (68 kg) for a three or more person lift. Keep clear of heavy parts supported only by lifting device. Failure to follow this warning may cause serious injury or death to personnel.

11. Using lifting device, lift dipperstick (2) with assembled parts clear of boom (9) and lower until resting firmly on wood blocks. Remove lifting device.

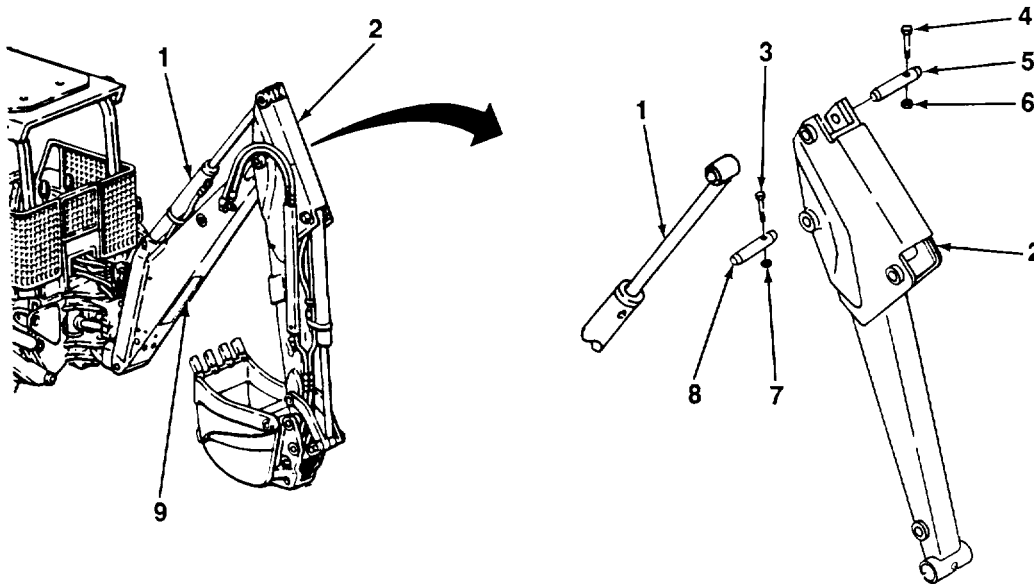
**b. DISASSEMBLY**

1. Remove backhoe bucket (see TM 5-2420-222-20).
2. Remove backhoe bucket linkage (see TM 5-2420-222-20).

TA701632

15-1. BACKHOE DIPPERSTICK MAINTENANCE (Con't).**WARNING**

Use extreme caution when handling heavy parts. Lifting device is required when parts weigh over 50 lb. (23 kg) for a single person lift, over 100 lb. (45 kg) for a two person lift, and over 150 lb. (68 kg) for a three or more person lift. Keep clear of heavy parts supported only by lifting device. Failure to follow this warning may cause serious injury or death to personnel.

3. Using lifting device, support bucket cylinder (10).
4. Remove screw (11) and nut (13) from dipperstick (2) and pin (12).
5. Drive pin (12) out of dipperstick (2) and bucket cylinder (10).
6. Using lifting device, remove bucket cylinder (10) from dipperstick (2).

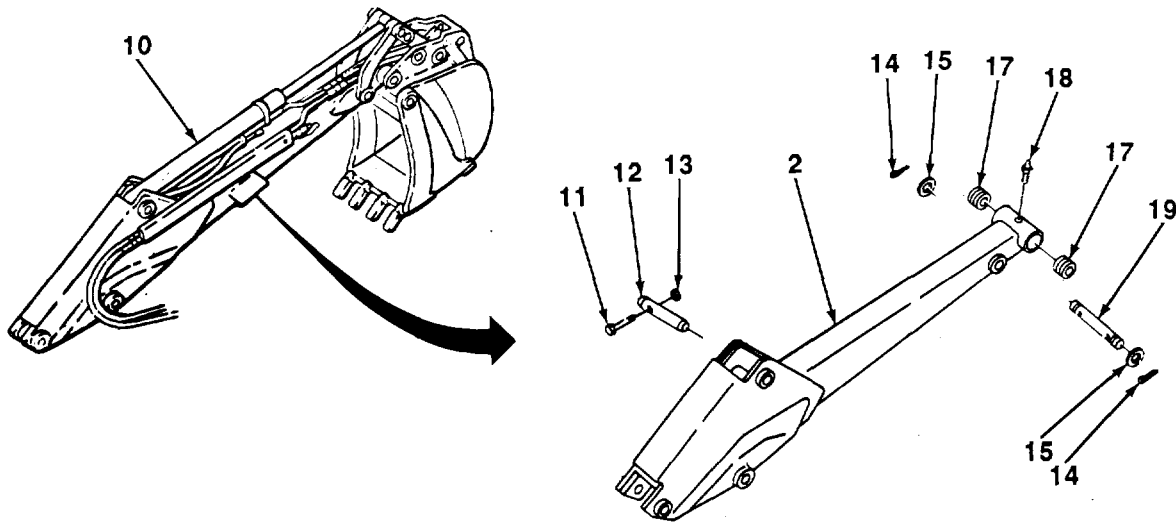
**CAUTION**

Do not remove bushings unless damaged. Removal may damage parts.

7. Using remover and installer and ball-peen hammer, drive two bushings (17) out of dipperstick (2).
8. Remove grease fitting (18) from dipperstick (2). Discard grease fitting.

NOTE

Perform steps 9 through 11 only on loader backhoes with serial numbers 235786-235999.

9. Remove two cotter pins (14) from pin (19). Discard cotter pins.
10. Remove two special washers (15) from pin (19).
11. Drive pin (19) out of dipperstick (2) with brass driftpin and ball-peen hammer.

TA701633

15-1. BACKHOE DIPPERSTICK MAINTENANCE (Con't).**NOTE**

Perform steps 12 and 13 only on loader backhoes with serial numbers 319995-342573.

12. Using retaining ring pliers, remove two retaining rings (20) from pin (21).
13. Drive pin (21) out of dipperstick (2) with brass driftpin and ball-peen hammer.

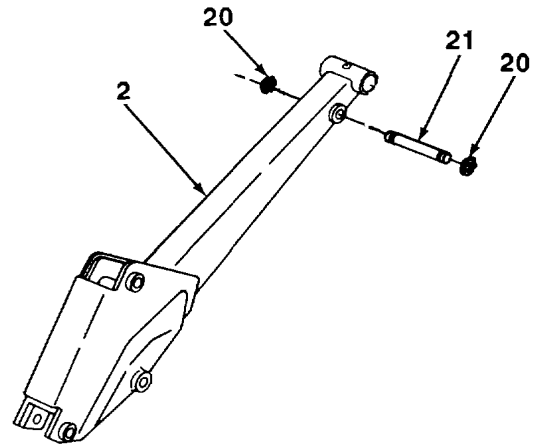
**CAUTION**

Do not remove bushings unless damaged. Removal may damage parts.

14. Using remover and installer and ball-peen hammer, drive two bushings (16) out of dipperstick (2).

c. CLEANING AND INSPECTION**WARNING**

Dry cleaning solvent, P-D-680, is toxic and flammable. Always wear protective goggles and gloves, and use only in a well-ventilated area. Avoid contact with skin, eyes, and clothes, and DO NOT breathe vapors. DO NOT use near open flame or excessive heat. The solvent's flash point is 1000F-1380F (380C-590C). If you become dizzy while using cleaning solvent, immediately get fresh air and medical help. If solvent contacts eyes, immediately wash your eyes and get medical aid.

1. Clean all metal parts with dry cleaning solvent and rags. Dry thoroughly with clean, dry rags.
2. Inspect metal parts for cracks, breaks, and abnormal bends.
3. Inspect dipperstick for damaged threads.

d. REPAIR

Restore damaged dipperstick threads using screw threading set.

e. ASSEMBLY**NOTE**

Perform steps 1 and 2 only if bushings were removed.

1. Using remover and Installer and ball-peen hammer, tap two bushings (16) in dipperstick (2).

TA701634

15-1. BACKHOE DIPPERSTICK MAINTENANCE (Con't).

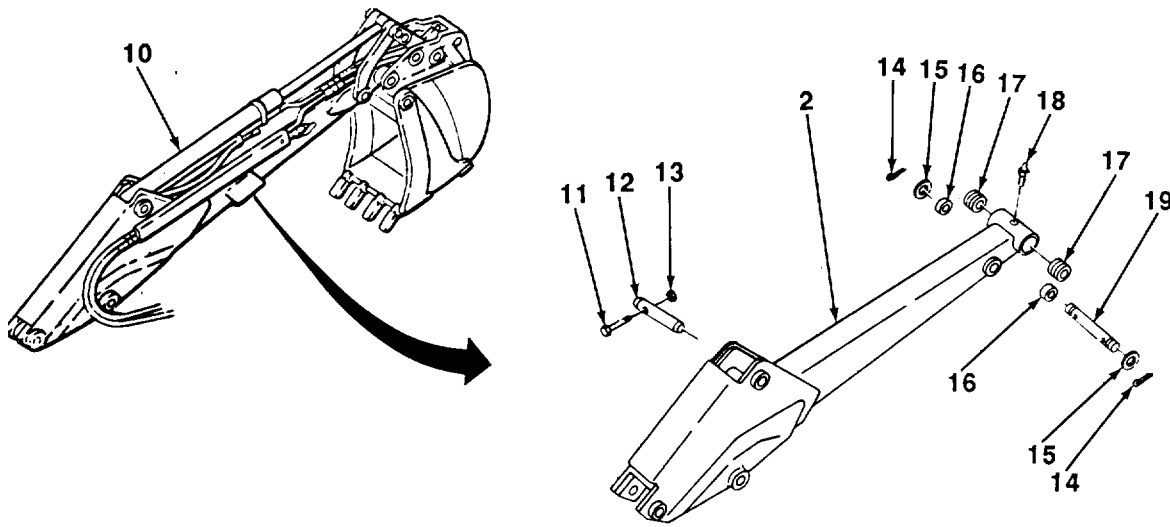

2. Using remover and installer and ball-peen hammer, tap two bushings (17) in dipperstick (2).

NOTE

Perform steps 3 through 5 only on loader backhoes with serial numbers 235786-235999.

3. Drive pin (19) in dipperstick (2) with ball-peen hammer and wood block.
4. Position two special washers (15) in place on pin (19).
5. Install two new cotter pins (14) in pin (19).

NOTE

Perform steps 6 and 7 only on loader backhoes with serial numbers 235786-235999.

6. Drive pin (21) in dipperstick (2) with ball-peen hammer and wood block.
7. Using retaining ring pliers, install two retaining rings (20) on pin (21).
8. Install new grease fitting (18) in dipperstick (2).

WARNING

Use extreme caution when handling heavy parts. Lifting device is required when parts weigh over 50 lb. (23 kg) for a single person lift, over 100 lb. (45 kg) for a two person lift, and over 150 lb. (68 kg) for a three or more person lift. Keep clear of heavy parts supported only by lifting device. Failure to follow this warning may cause serious injury or death to personnel.

9. Using lifting device, position bucket cylinder (10) in place on dipperstick (2) with pin holes aligned.
10. Drive pin (12) in dipperstick (2) and bucket cylinder (10) with ball-peen hammer and wood block.
11. Install screw (11) and nut (13) in dipperstick (2) and pin (12).

15-1. BACKHOE DIPPERSTICK MAINTENANCE (Con't).

12. Install backhoe bucket linkage (see TM 5-2420-222-20).
13. Install backhoe bucket (see TM 5-2420-222-20).

f. INSTALLATION**WARNING**

Use extreme caution when handling heavy parts. Lifting device is required when parts weigh over 50 lb. (23 kg) for a single person lift, over 100 lb. (45 kg) for a two person lift, and over 150 lb. (68 kg) for a three or more person lift. Keep clear of heavy parts supported only by lifting device. Failure to follow this warning may cause serious injury or death to personnel.

1. Using lifting device, position dipperstick (2) with assembled parts in place on boom (9) with pin holes aligned.
2. Drive pin (8) in dipperstick (2) and boom (9) with ball-peen hammer and wood block.
3. Install screw (3) and nut (7) in dipperstick (2) and pin (8).
4. Remove wood blocks from under crowd cylinder (1) and position on dipperstick (2) with pin holes aligned.
5. Drive pin (5) in dipperstick (2) and crowd cylinder (1) with ball-peen hammer and wood block.
6. Install screw (4) and nut (6) in dipperstick (2) and pin (5).

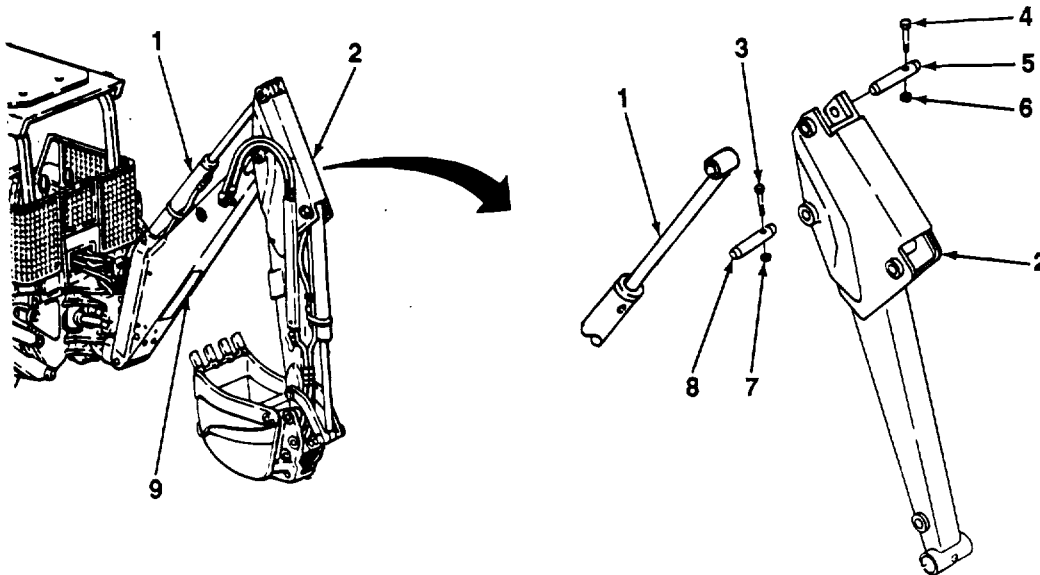

7. Install hydraulic impactor flow regulator-to-nipple quick coupler oil lines (see TM 5-2420-222-20).
8. Install backhoe control valve-to-female quick coupler oil lines (see TM 5-2420-222-20).
9. Install manifold block-to-jaw cylinder oil hose oil line (see TM 5-2420-222-20).
10. Remove lifting device from dipperstick (2) with assembled parts.

TA701636

15-1. BACKHOE DIPPERSTICK MAINTENANCE (Con't).

11. Start engine assembly (see TM 5-2420-222-10).
12. Raise backhoe boom, dipperstick, and bucket off wood blocks. Remove wood blocks.
13. Shut down engine assembly (see TM 5-2420-222-10).

15-2. BACKHOE BOOM MAINTENANCE.

This Task Covers:

- | | | | |
|----|-------------------------|----|--------------|
| a. | Removal | d. | Repair |
| b. | Disassembly | e. | Assembly |
| c. | Cleaning and Inspection | f. | Installation |

Initial Setup:

Equipment Conditions:

- Boom cylinder removed (see TM 5-2420-222-20).
- Crowd cylinder removed (see TM 5-2420-222-20).
- Backhoe dipperstick removed (see paragraph 15-1).

Tools/Test Equipment:

- General mechanic's tool kit
- Field automotive shop set

Materials/Parts:

- Rags (Item 28, Appendix B)
- Dry cleaning solvent (Item 31, Appendix B)

Personnel Required: Two**General Safety Instructions:**

- Dry cleaning solvent is flammable and must not be used near open flame. Use only in a well-ventilated area.

a. REMOVAL**WARNING**

Use extreme caution when handling heavy parts. Lifting device is required when parts weigh over 50 lb. (23 kg) for a single person lift, over 100 lb. (45 kg) for a two person lift, and over 150 lb (68 kg) for a three or more person lift. Keep clear of heavy parts supported only by lifting device. Failure to follow this warning may cause serious injury or death to personnel.

1. Using lifting device, support backhoe boom (1).
2. Remove two screws (2) and nuts (3) from backhoe boom (1) and two pins (4).
3. Using mechanical slide hammer-type puller, remove two pins (4) and washers (5) from backhoe boom (1) and swing frame.
4. Using lifting device, lower backhoe boom (1) away from swing frame and set on wood blocks. Remove lifting device from backhoe boom.

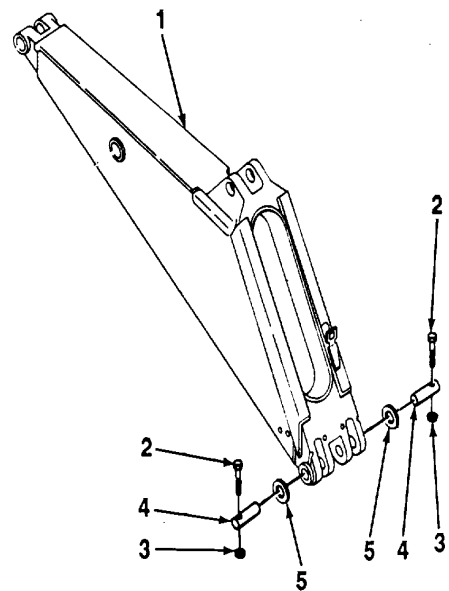

15-2. BACKHOE BOOM MAINTENANCE (Con't).**b. DISASSEMBLY****CAUTION**

Do not remove bushings unless damaged. Removal may damage parts.

1. Using remover and installer and ball-peen hammer, drive bushing (6) out of backhoe boom (1).
2. Using remover and installer and ball-peen hammer, drive bushing (7) out of backhoe boom (1).

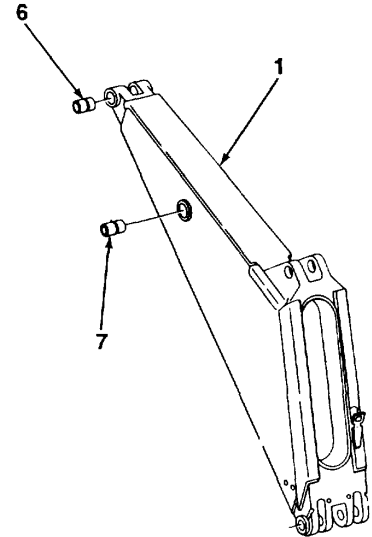
**c. CLEANING AND INSPECTION****WARNING**

Dry cleaning solvent, P-D-680, is toxic and flammable. Always wear protective goggles and gloves, and use only in a well-ventilated area. Avoid contact with skin, eyes, and clothes, and DO NOT breathe vapors. DO NOT use near open flame or excessive heat. The solvent's flash point is 100°F-138°F (38°C-59°C). If you become dizzy while using cleaning solvent, immediately get fresh air and medical help. If solvent contacts eyes, immediately wash your eyes and get medical aid.

1. Clean backhoe boom with dry cleaning solvent and rags. Dry thoroughly with clean, dry rags.
2. Clean all other metal parts with dry cleaning solvent and rags. Dry thoroughly with clean, dry rags.
3. Inspect all metal parts for cracks, breaks, and abnormal bends.
4. Inspect backhoe boom for damaged threads.

d. REPAIR

Restore damaged backhoe boom (1) threads using screw threading set.

e. ASSEMBLY**NOTE**

Perform steps 1 and 2 only if bushings were removed.

1. Using remover and installer and ball-peen hammer, tap bushing (7) in backhoe boom (1).
2. Using remover and installer and ball-peen hammer, tap bushing (6) in backhoe boom (1).

TA701638

15-2. BACKHOE BOOM MAINTENANCE (Con't).

f. INSTALLATION
WARNING

Use extreme caution when handling heavy parts. Lifting device is required when parts weigh over 50 lb. (23 kg) for a single person lift, over 100 lb. (45 kg) for a two person lift, and over 150 lb. (68 kg) for a three or more person lift. Keep clear of heavy parts supported only by lifting device. Failure to follow this warning may cause serious injury or death to personnel.

1. Using lifting device, position backhoe boom (1) in place on swing frame with pin holes alined.
2. Position two washers (5) between backhoe boom (1) and swing frame and install two pins (4) with screw holes alined.
3. Install two screws (2) and nuts (3) in backhoe boom (1) and pins (4).
4. Remove lifting device from backhoe boom (1).

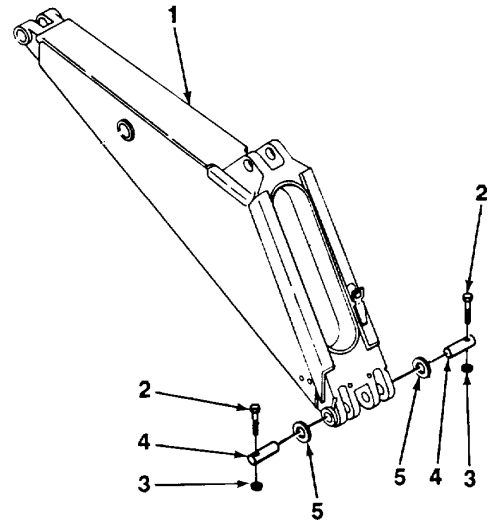
FOLLOW-ON TASKS:

- Install backhoe dipperstick (see paragraph 15-1).
- Install crowd cylinder (see TM 5-2420-222-20).
- Install boom cylinder (see TM 5-2420-222-20).

15-3. BACKHOE SWING FRAME MAINTENANCE.

This Task Covers:

- | | |
|----------------------------|-----------------|
| a. Removal | d. Repair |
| b. Disassembly | e. Assembly |
| c. Cleaning and Inspection | f. Installation |

Initial Setup.

Equipment Conditions:

- Backhoe boom removed (see paragraph 15-2).
- Manifold block removed (see TM 5-2420-222-20).

Tools/Test Equipment:

- General mechanic's tool kit
- Field automotive shop set

Personnel Required: Two

Materials/Parts:

- Rags (Item 28, Appendix B)
- Dry cleaning solvent (Item 31, Appendix B)
- Four cotter pins
- Five grease fittings

General Safety Instructions:

- Dry cleaning solvent is flammable and must not be used near open flame. Use only in a well-ventilated area.

a. REMOVAL

1. Remove screw (1), two washers (4), and nut (5) from swing frame (6) and main frame (2).
2. Drive pin (7) and sleeve spacer (3) out of swing frame (6) and main frame (2).

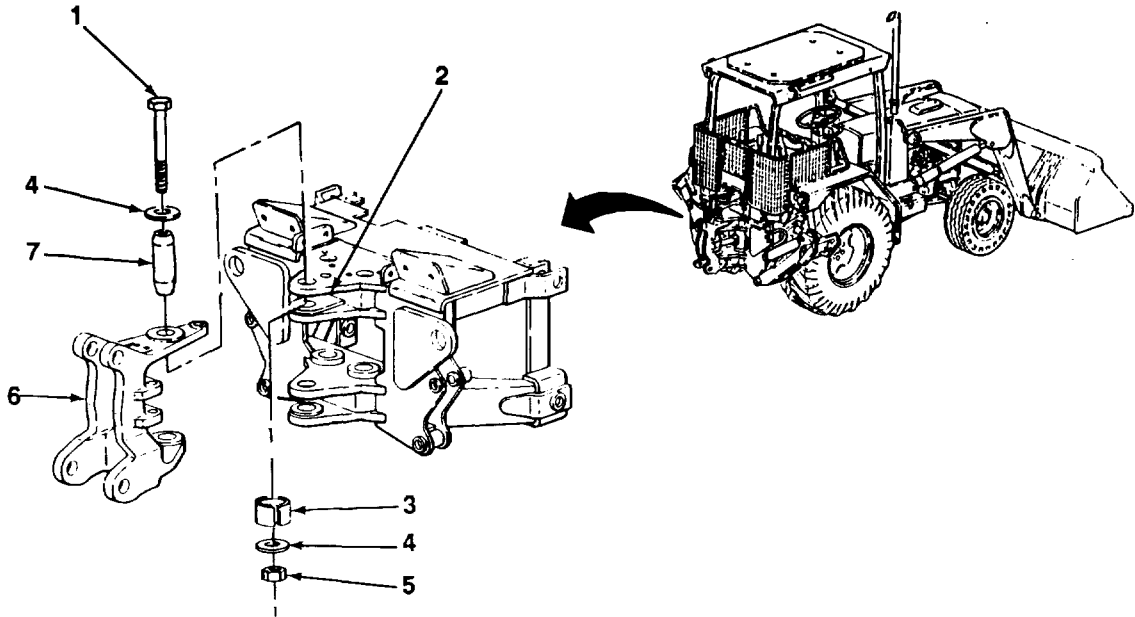

15-3. BACKHOE SWING FRAME MAINTENANCE (Con't).

3. Using ball-peen hammer and brass drift, drive sleeve bushing (8) out of swing frame (6) and main frame (2).
4. Remove screw (11), two washers (10), and nut (14) from swing frame (6) and main frame (2).
5. Drive pin (12) and sleeve spacer (9) out of swing frame (6) and main frame (2).
6. Using ball-peen hammer and brass drift, drive sleeve bushing (13) out of swing frame (6) and main frame (2).

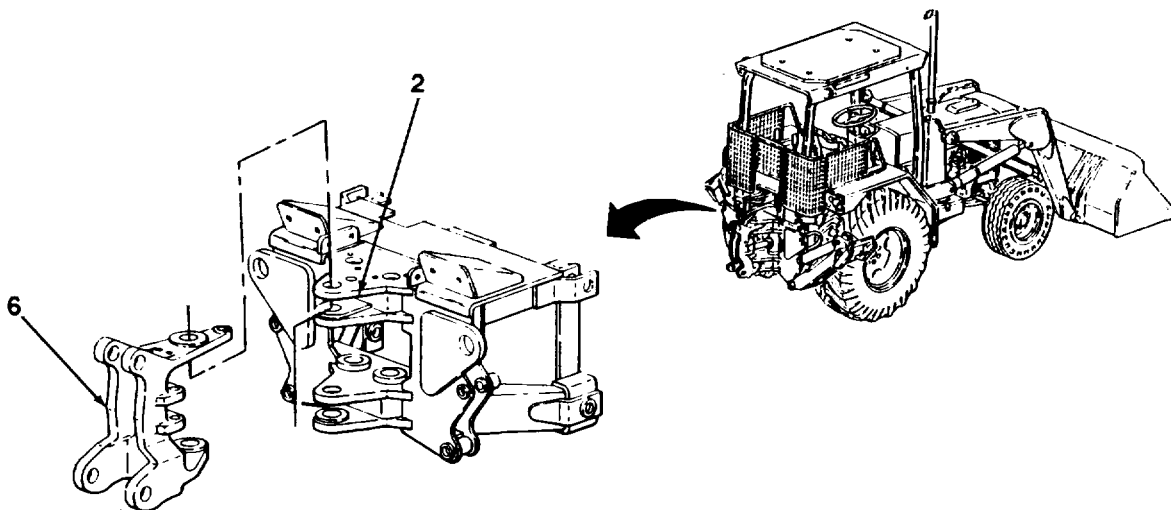
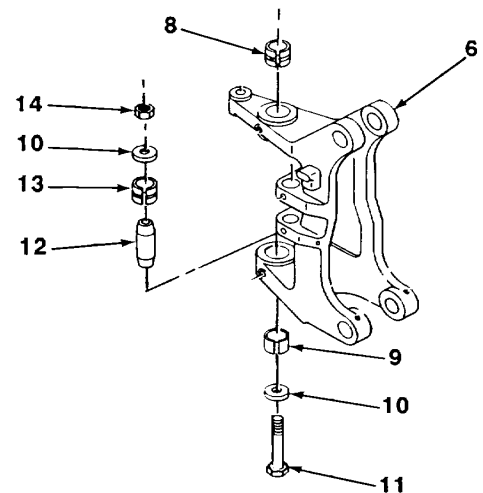

WARNING

Use extreme caution when handling heavy parts. Lifting device is required when parts weigh over 50 lb. (23 kg) for a single person lift, over 100 lb. (45 kg) for a two person lift, and over 150 lb. (68 kg) for a three or more person lift. Keep clear of heavy parts supported only by lifting device. Failure to follow this warning may cause serious injury or death to personnel.

7. Using lifting device, support swing frame (6).

TA701641

15-3. BACKHOE SWING FRAME MAINTENANCE (Con't).**NOTE**

Some swing frames have linkage pins retained by cotter pins; some have linkage pins retained by retaining rings. For swing frames equipped with cotter pins, perform step 8 and skip step 9. For swing frames equipped with retaining rings, skip step 8 and perform step 9.

8. Remove four cotter pins (16) and washers (17) from two pins (18). Discard cotter pins.
9. Remove four retaining rings (15) from two pins (20).
10. Drive two pins (18 or 20) from swing frame (6) and swing cylinders (21).
11. Using lifting device, lower swing frame (6) away from main frame (2) and set on wood blocks. Remove lifting device from swing frame.
12. Remove four spacers or washers (19) from swing frame (6) or main frame (2).

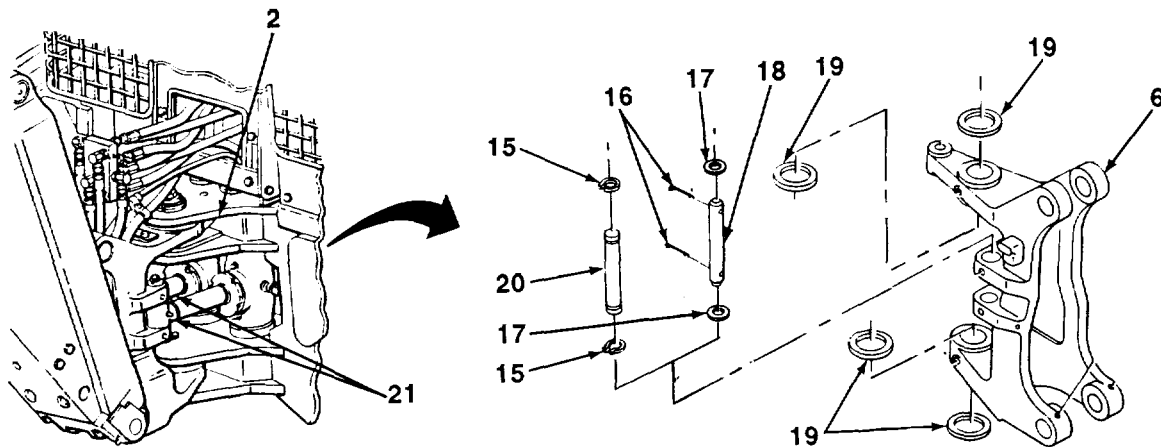

TA701642

15-3. BACKHOE SWING FRAME MAINTENANCE (Con't),**b. DISASSEMBLY**

1. Remove three grease fittings (22) from swing frame (6). Discard grease fittings.

CAUTION

Do not remove sleeve bushings unless damaged. Removal may damage parts.

2. Using ball-peen hammer and brass drift, drive two sleeve bushings (23) out of swing frame (6).
3. Using ball-peen hammer and brass drift, drive two sleeve bushings (25) out of swing frame (6).
4. Using ball-peen hammer and brass drift, drive two sleeve bushings (26) out of swing frame (6).
5. Remove two grease fittings (24) from swing frame (6). Discard grease fittings.

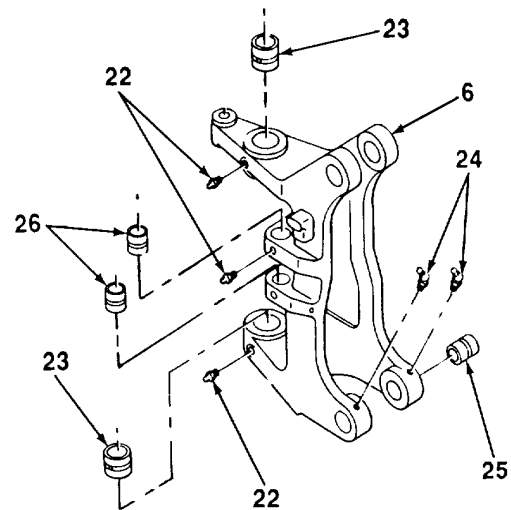
**c. CLEANING AND INSPECTION****WARNING**

Dry cleaning solvent, P-D-680, is toxic and flammable. Always wear protective goggles and gloves, and use only in a well-ventilated area. Avoid contact with skin, eyes, and clothes, and DO NOT breathe vapors. DO NOT use near open flame or excessive heat. The solvent's flash point is 100°F-138°F (38°C-59°C). If you become dizzy while using cleaning solvent, immediately get fresh air and medical help. If solvent contacts eyes, immediately wash your eyes and get medical aid.

1. Clean swing frame with dry cleaning solvent and rags. Dry thoroughly with clean, dry rags.
2. Clean all other metal parts with dry cleaning solvent and rags. Dry thoroughly with clean, dry rags.
3. Inspect all metal parts for cracks, breaks, and abnormal bends.
4. Inspect swing frame for damaged threads.

d. REPAIR

Restore damaged swing frame (6) threads using screw threading set.

e. ASSEMBLY

1. Install two new grease fittings (24) in swing frame (6).

TA701643

15-3. BACKHOE SWING FRAME MAINTENANCE (Con't).**NOTE**

Perform steps 2 through 4 only if sleeve bushings were removed.

2. Using ball-peen hammer and brass drift, tap two sleeve bushings (26) in swing frame (6).
3. Using ball-peen hammer and brass drift, tap two sleeve bushings (25) in swing frame (6).
4. Using ball-peen hammer and brass drift, tap two sleeve bushings (23) in swing frame (6).
5. Install three new grease fittings (22) in swing frame (6).

f. INSTALLATION

1. Install four spacers or washers (19) on swing frame (6) and main frame (2).

WARNING

Use extreme caution when handling heavy parts. Lifting device is required when parts weigh over 50 lb. (23 kg) for a single person lift, over 100 lb. (45 kg) for a two person lift, and over 150 lb. (68 kg) for a three or more person lift. Keep clear of heavy parts supported only by lifting device. Failure to follow this warning may cause serious injury or death to personnel.

2. Using lifting device, position swing frame (6) and four washers (19) in place on main frame (2) with pin holes aligned.

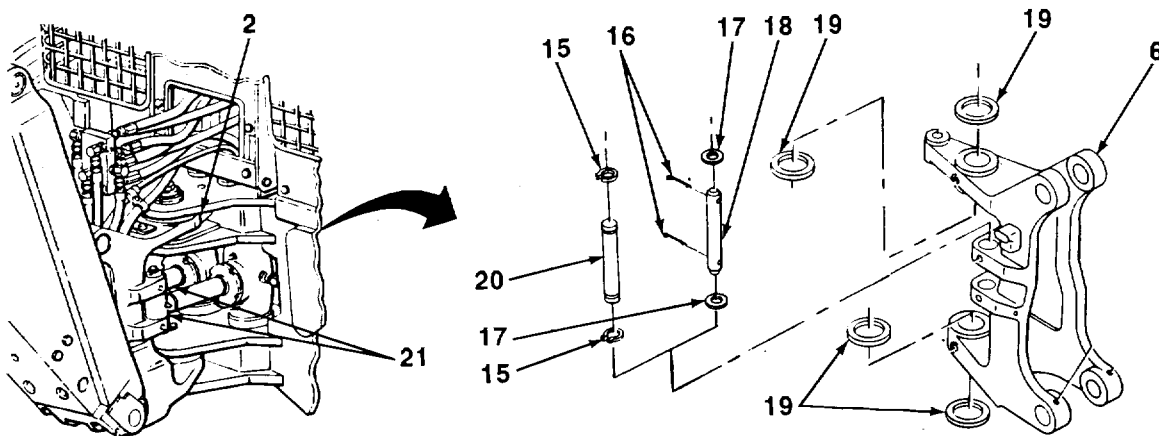

3. Install two pins (18 or 20) in swing frame (6) and swing cylinders (21).

NOTE

Some swing frames have linkage pins retained by cotter pins; some have linkage pins retained by retaining rings. For swing frames equipped with cotter pins, perform step 4 and skip step 5. For swing frames equipped with retaining rings, skip step 4 and perform step 5.

4. Install four washers (17) and new cotter pins (16) in two pins (18).
5. Install four retaining rings (15) on two pins (20).

TA701644

15-3. BACKHOE SWING FRAME MAINTENANCE (CON'T).

6. Using ball-peen hammer and brass drift, install sleeve bushing (13) in swing frame (6).
7. Install pin (12) and sleeve spacer (9) in swing frame (6) and main frame (2).
8. Install two washers (10), screw (11), and nut (14) in swing frame (6) and main frame (2).
9. Using ball-peen hammer and brass drift, install sleeve bushing (8) in swing frame (6).
10. Install pin (7) and sleeve spacer (3) in swing frame (6) and main frame (2).
11. Install two washers (4), screw (1), and nut (5) in swing frame (6) and main frame (2).
12. Remove lifting device from swing frame (6).

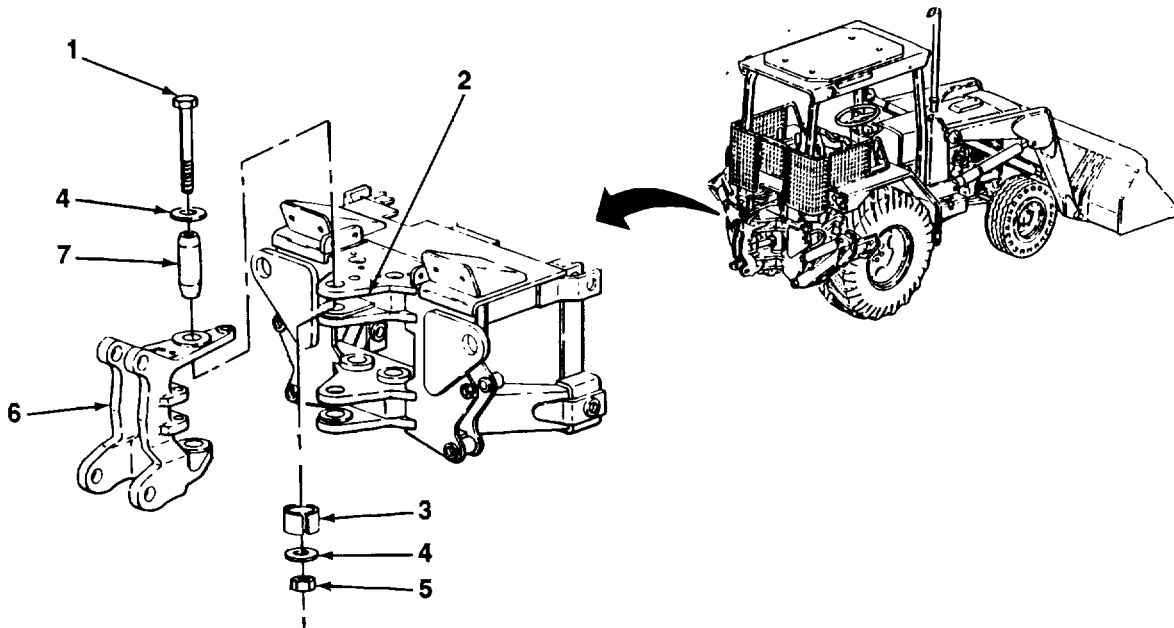
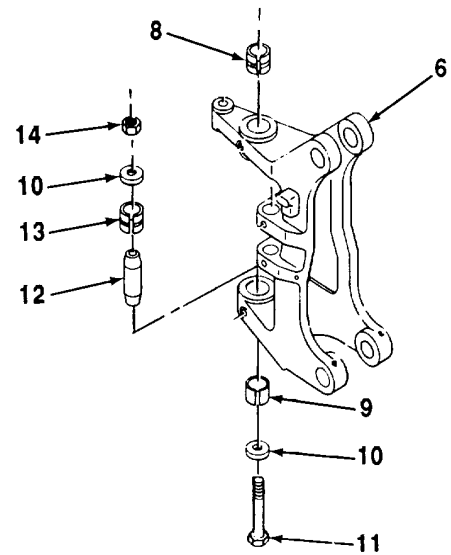

FOLLOW-ON TASKS:

- Install manifold block (see TM 5-2420-222-20).
- Install backhoe boom (see paragraph 15-2).

TA701645

15-4. BACKHOE MAIN FRAME MAINTENANCE.

This Task Covers:

- | | |
|----------------------------|-----------------|
| a. Removal | d. Repair |
| b. Disassembly | e. Assembly |
| c. Cleaning and Inspection | f. Installation |

Initial Setup:

Equipment Conditions:

- Backhoe swing frame removed (see paragraph 15-3).
- Backhoe valve box removed (see TM 5-2420-222-20).
- Jaw control (direct linear) valve bracket removed (see TM 5-2420-222-20).
- Rear tire and wheel assemblies removed (see TM 2420-222-20).
- Right platform removed (see TM 5-2420-222-20).
- Left platform removed (see TM 5-2420-222-20).
- Left and right fenders removed (see TM 5-2420-222-20).

Materials/Parts:

- Rags (Item 28, Appendix B)
- Dry cleaning solvent (Item 31, Appendix B)
- Four cotter pins
- Four lockwashers

References:

- TM 5-2420-222-20
- TM 9-237

Personnel Required: Three

General Safety Instructions:

- Dry cleaning solvent is flammable and must not be used near open flame. Use only in a well-ventilated area.

Tools/Test Equipment:

- General mechanic's tool kit
- Field automotive shop set

a. REMOVAL

1. Position two jackstands under frame near rear axles.

WARNING

Use extreme caution when handling heavy parts. Lifting device is required when parts weigh over 50 lb. (23 kg) for a single person lift, over 100 lb. (45 kg) for a two person lift, and over 150 lb. (68 kg) for a three or more person lift. Keep clear of heavy parts supported only by lifting device. Failure to follow this warning may cause serious injury or death to personnel.

2. Using lifting device, support main frame (1).
3. Remove four screws (3), lockwashers (4), and two plates (2) from main frame (1). Discard lockwashers.

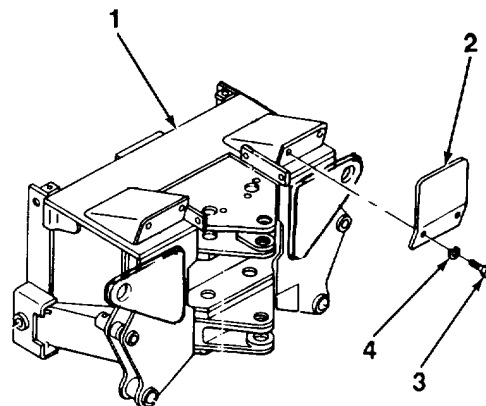

15-4. BACKHOE MAIN FRAME MAINTENANCE (Con't).

4. Remove two screws (7) and nuts (8) from main frame (1) and two pins (12).
5. Drive two pins (12) out of main frame (1) and two towbars (6).
6. Remove four cotter pins (9) from two pins (10) and side frames (11). Discard cotter pins.
7. Drive two pins (10) out of main frame (1) and two side frames (11).
8. Using lifting device and the aid of two assistants, lift main frame (1) off two towbars (6) and side frames (11) and set on wood blocks.
9. Remove lifting device from main frame (1).
10. Using retaining ring pliers, remove four retaining rings (5) from two pins (13) and side frames (11).

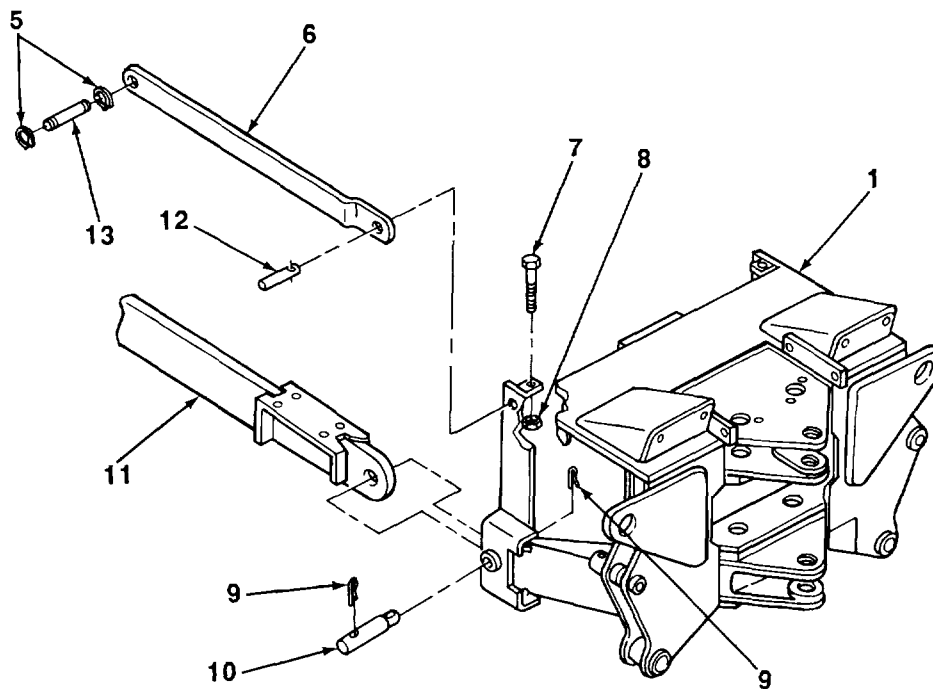
**b. DISASSEMBLY**

1. Remove backhoe control valve-to-stabilizer cylinder oil lines (see TM 5-2420-222-20).
2. Remove backhoe stabilizer cylinders (see TM 5-2420-222-20).
3. Remove stabilizers (see TM 5-2420-222-20).
4. Remove hydraulic impactor valve (see TM 5-2420-222-20).
5. Remove swing cylinders (see TM 5-2420-222-20).
6. If damaged, remove decal (see TM 5-2420-222-20).

15-4. BACKHOE MAIN FRAME MAINTENANCE (Con't).**CAUTION**

Do not remove sleeve bushings unless damaged. Removal may damage parts.

7. Using remover and installer and ball-peen hammer, remove four sleeve bushings (14) from main frame (1).

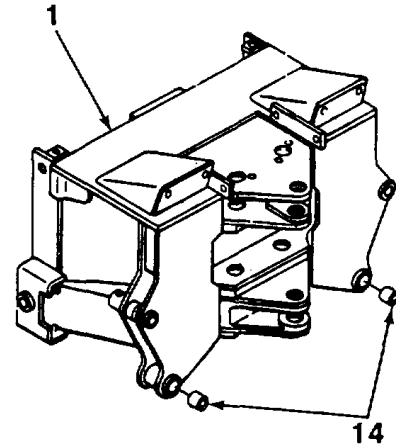
**c. CLEANING AND INSPECTION****WARNING**

Dry cleaning solvent, P-D-680, is toxic and flammable. Always wear protective goggles and gloves, and use only in a well-ventilated area. Avoid contact with skin, eyes, and clothes, and DO NOT breathe vapors. DO NOT use near open flame or excessive heat. The solvent's flash point is 100°F-138°F (38°C-59°C). If you become dizzy while using cleaning solvent, immediately get fresh air and medical help. If solvent contacts eyes, immediately wash your eyes and get medical aid.

1. Clean main frame with dry cleaning solvent and rags. Dry thoroughly with clean, dry rags.
2. Clean all other metal parts with dry cleaning solvent and rags. Dry thoroughly with clean, dry rags.
3. Inspect main frame for cracks, breaks, abnormal bends, and damaged threads.
4. Inspect all other metal parts for cracks, breaks, and abnormal bends.

d. REPAIR

1. If main frame (1) has cracks, breaks, or broken welds, repair by welding (see TM 9-237).
2. Restore damaged main frame (1) threads using screw threading set.

e. ASSEMBLY**NOTE**

Perform step 1 only if sleeve bushings were removed.

1. Using a suitable press, install four sleeve bushings (14) in main frame (1).
2. If removed, install decal (see TM 5-2420-222-20).

TA701648

15-4. BACKHOE MAIN FRAME MAINTENANCE (Con't).

3. Install swing cylinders (see TM 5-2420-222-20).
4. Install hydraulic impactor valve (see TM 5-2420-222-20).
5. Install stabilizers (see TM 5-2420-222-20).
6. Install backhoe stabilizer cylinders (see TM 5-2420-222-20).
7. Install backhoe control valve-to-stabilizer cylinder oil lines (see TM 5-2420-222-20).

f. INSTALLATION

1. With the aid of an assistant, position two towbars (6) in place on side frames (11).
2. Install two pins (13) in side frames (11) and towbars (6) with ball-peen hammer and wood block.
3. Using retaining ring pliers, install four retaining rings (5) on pins (13).

WARNING

Use extreme caution when handling heavy parts. Lifting device is required when parts weigh over 50 lb (23 kg) for a single person lift, over 100 lb (45 kg) for a two person lift, and over 150 lb (68 kg) for a three or more person lift. Keep clear of heavy parts supported only by lifting device. Failure to follow this warning may cause serious injury or death to personnel.

4. Using lifting device and the aid of two assistants, raise and position main frame (1) in place on side frames (11) and towbars (6) with pin holes alined.
5. Install two pins (10) in main frame (1) and two side frames (11). Install four new cotter pins (9) in pins.

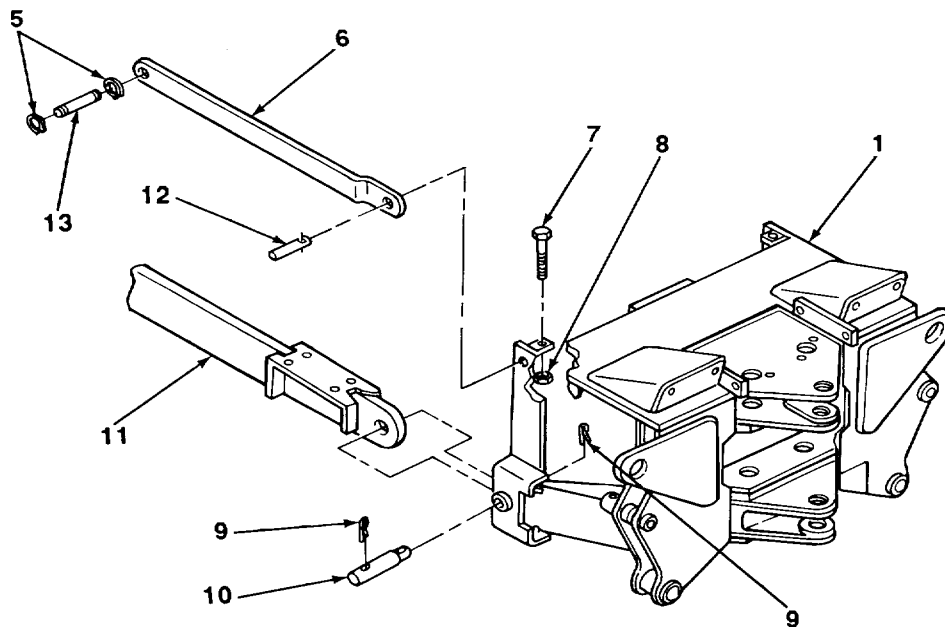

TA701649

15-4. BACKHOE MAIN FRAME MAINTENANCE (Con't).

6. Install two pins (12) in main frame (1) and two towbars (6).
7. Install two screws (7) and nuts (8) in main frame (1) and pins (12).
8. Position two plates (2) in place on main frame (1) and secure with four screws (3) and new lockwashers (4).
9. Remove lifting device from main frame (1) and two jackstands from under side frames (11).

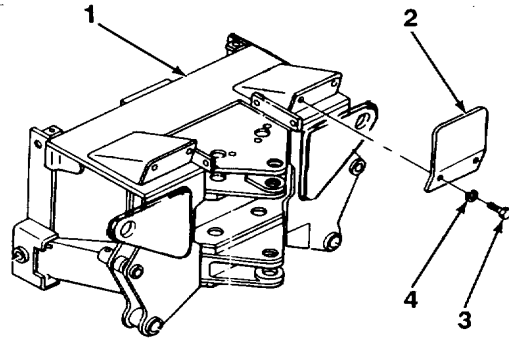
**FOLLOW-ON TASKS:**

- Install left and right fenders (see TM 5-2420-222-20).
- Install left platform (see TM 5-2420-222-20).
- Install right platform (see TM 5-2420-222-20).
- Install rear tire and wheel assemblies (see TM 5-2420-222-20).
- Install jaw control (direct linear) valve bracket (see TM 5-2420-222-20).
- Install backhoe valve box (see TM 5-2420-222-20).
- Install backhoe swing frame (see paragraph 15-3).

Section II. LOADER ASSEMBLY MAINTENANCE

Paragraph Number	Paragraph Title	Page Number
15-5	Loader Lift Arms Maintenance	15-22
15-6	Loader Side Frames Maintenance	15-28

15-5. LOADER LIFT ARMS MAINTENANCE.

This Task Covers:

- | | |
|----------------------------|-----------------|
| a. Removal | d. Repair |
| b. Disassembly | e. Assembly |
| c. Cleaning and Inspection | f. Installation |

Initial Setup:

Equipment Conditions:

- Loader bucket cylinders removed (see TM 5-2420-222-20).
- Loader bucket removed (see TM 5-2420-222-20).
- Front lights removed (see TM 5-2420-222-20).

Materials/Parts:

- Rags (Item 28, Appendix B)
- Dry cleaning solvent (Item 31, Appendix B)
- Two locknuts
- Four retaining rings

Tools/Test Equipment:

- General mechanic's tool kit
- Field automotive shop set

Personnel Required: Two

General Safety Instructions:

- Dry cleaning solvent is flammable and must not be used near open flame. Use only in a well-ventilated area.

References:

- TM 5-2420-222-20
- TM 9-237

a. REMOVAL

WARNING

Use extreme caution when handling heavy parts. Lifting device is required when parts weigh over 50 lb (23 kg) for a single person lift, over 100 lb (45 kg) for a two person lift, and over 150 lb (68 kg) for a three or more person lift. Keep clear of heavy parts supported only by lifting device. Failure to follow this warning may cause serious injury or death to personnel.

1. Using lifting device, support lift arms (3).

NOTE

Both boom cylinder grooved pins are removed the same way. One is shown. Repeat steps 2 through 4 for other grooved pin.

2. Using retaining ring pliers, remove two retaining rings (4) from grooved pin (5). Discard retaining rings.

15-5. LOADER LIFT ARMS MAINTENANCE (Con't).

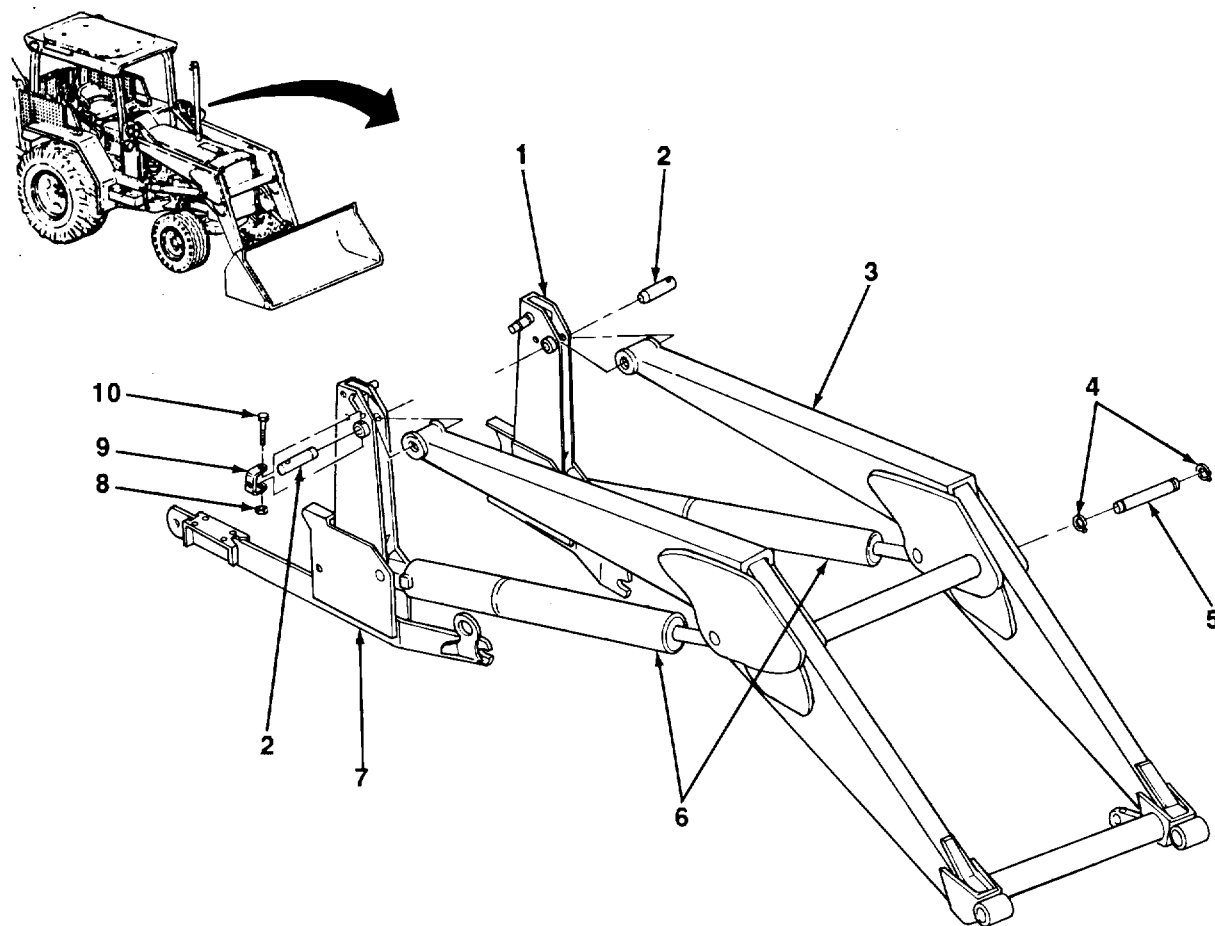

3. While assistant supports boom cylinder (6), drive grooved pin (5) out of lift arms (3) and boom cylinder with brass drift and ball-peen hammer.
4. Lower boom cylinder (6) to rest on frame assembly front support.
5. Remove two screws (10), locknuts (8), and light brackets (9) from pins (2) and side frames (1 and 7). Discard locknuts.
6. Drive two pins (2) out of lift arms (3) and side frames (1 and 7) with brass drift and ball-peen hammer.
7. Using lifting device, remove lift arms (3) clear of side frames (1 and 7) and set on wood blocks. Remove lifting device from lift arms.

15-5. LOADER LIFT ARMS MAINTENANCE (Con't).

b. DISASSEMBLY

1. If damaged, remove four grease fittings (11) from lift arms (3).

NOTE

Do not remove sleeve bushings unless damaged. Removal may damage parts.

2. Using drift and ball-peen hammer, drive four sleeve bushings (12) out of lift arms (3).
3. Using drift and ball-peen hammer, drive two sleeve bushings (14) out of lift arms (3).
4. Using drift and ball-peen hammer, drive four sleeve bushings (13) out of lift arms (3).
5. If damaged, remove identification and name plates (see TM 5-2420-222-20).

c. CLEANING AND INSPECTION**WARNING**

Dry cleaning solvent, P-D-680, is toxic and flammable. Always wear protective goggles and gloves, and use only in a well-ventilated area. Avoid contact with skin, eyes, and clothes, and DO NOT breathe vapors. DO NOT use near open flame or excessive heat. The solvent's flash point is 100°F-138°F (38°C-59°C). If you become dizzy while using cleaning solvent, immediately get fresh air and medical help. If solvent contacts eyes, immediately wash your eyes and get medical aid.

1. Clean lift arms and all other metal parts with dry cleaning solvent and rags. Dry thoroughly with clean, dry rags.
2. Inspect lift arms and all other metal parts for cracks, breaks, abnormal bends, and damaged threads.

d. REPAIR

1. Restore damaged lift arm (3) threads using screw threading set.
2. If cracks, breaks, or broken welds were found, repair by welding (see TM 9-237).

e. ASSEMBLY

1. If removed, install identification and name plates (see TM 5-2420-222-20).
2. If removed, install four grease fittings (11) in lift arms (3).

NOTE

Perform steps 3 through 5 only if sleeve bushings were removed.

3. Using drift and ball-peen hammer, install four sleeve bushings (12) in lift arms (3).
4. Using drift and ball-peen hammer, install two sleeve bushings (14) in lift arms (3).
5. Using drift and ball-peen hammer, install four sleeve bushings (13) in lift arms (3).

15-5. LOADER LIFT ARMS MAINTENANCE (Con't).

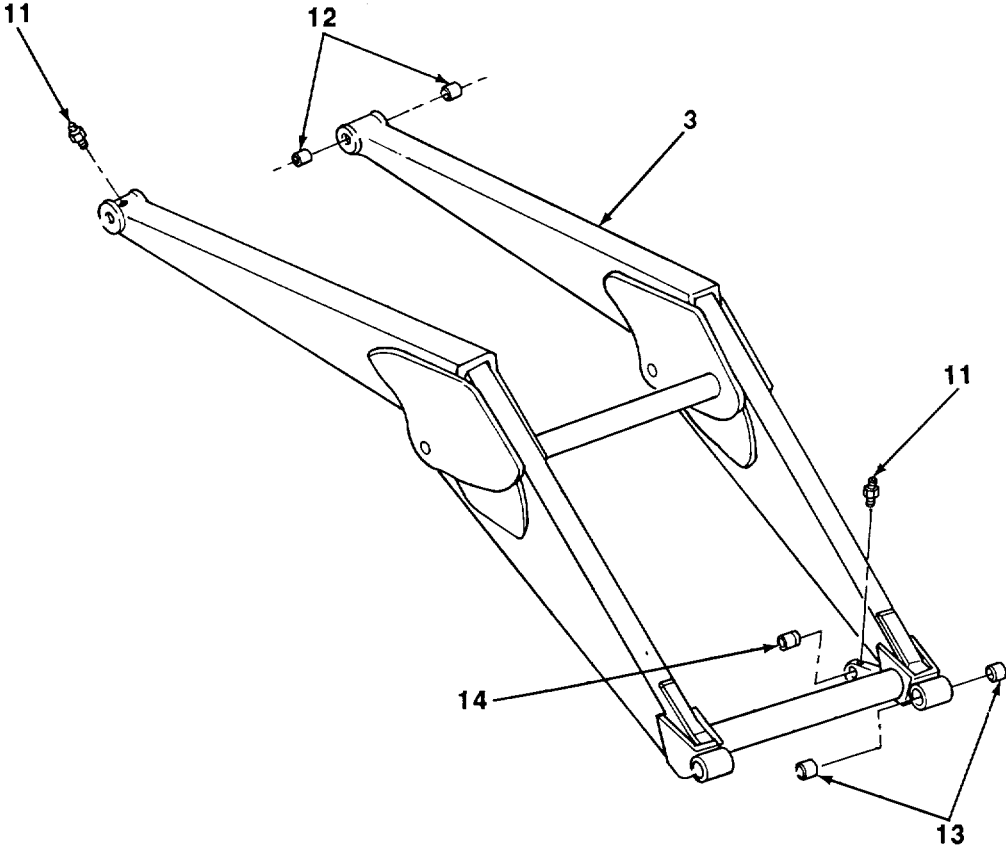

15-5. LOADER LIFT ARMS MAINTENANCE (Con't).

f. INSTALLATION**WARNING**

Use extreme caution when handling heavy parts. Lifting device is required when parts weigh over 50 lb (23 kg) for a single person lift, over 100 lb (45 kg) for a two person lift, and over 150 lb (68 kg) for a three or more person lift. Keep clear of heavy parts supported only by lifting device. Failure to follow this warning may cause serious injury or death to personnel.

1. Using lifting device, raise lift arms (3) into position on side frames (1 and 7) with pin holes aligned.
2. Install two pins (2) in side frames (1 and 7) with screw holes aligned. Drive pins in side frames and lift arms (3) with brass drift and ball-peen hammer.
3. Position two light brackets (9) in place on side frames (1 and 7). Install two screws (10) and new locknuts (8) through light brackets, side frames, and pins (2).

NOTE

Both boom cylinder grooved pins are installed the same way. One is shown. Repeat steps 4 through 6 for other boom cylinder.

4. With the aid of an assistant, raise boom cylinder (6) into position so grooved pin (5) holes align.
5. Drive grooved pin (5) in lift arms (3) and boom cylinder (6) with brass drift and ball-peen hammer.
6. Using retaining ring pliers, install two new retaining rings (4) on grooved pin (5).
7. Remove lifting device from lift arms (3).

15-5. LOADER LIFT ARMS MAINTENANCE (Con't).

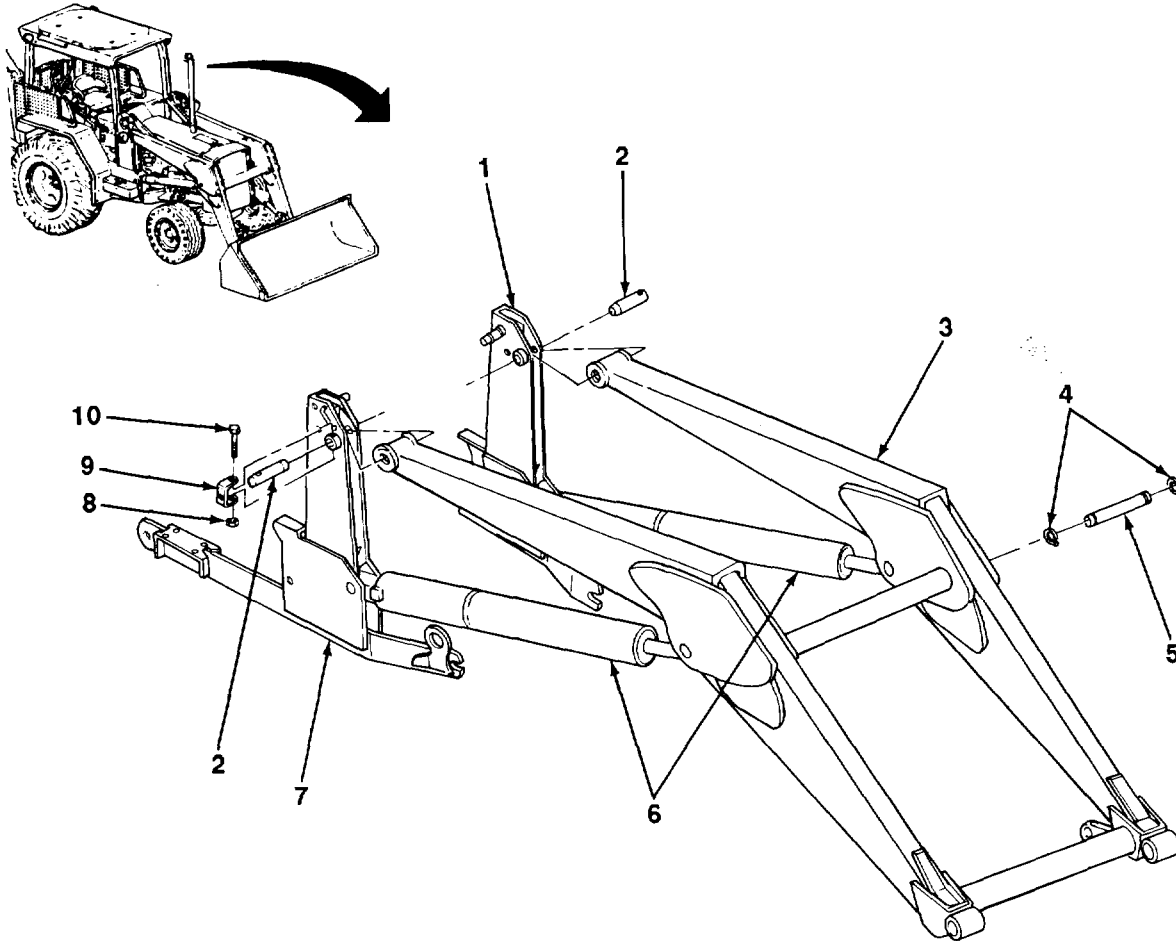

FOLLOW-ON TASKS

- Install front lights (see TM 5-2420-222-20).
- Install loader bucket (see TM 5-2420-222-20).
- Install loader bucket cylinders (see TM 5-2420-222-20).

15-6. LOADER SIDE FRAMES MAINTENANCE.

This Task Covers:

- | | |
|----------------------------|-----------------|
| a. Removal | d. Repair |
| b. Disassembly | e. Assembly |
| c. Cleaning and Inspection | f. Installation |

Initial Setup:

Equipment Conditions:

- Roll-over protective structure (ROPS) or canopy rear mounts removed (see paragraph 13-4).
- Frame assembly front support removed (see paragraph 12-1).
- Loader lift arms removed (see paragraph 15-5).
- Loader boom cylinders removed (see TM 5-2420-222-20).

NOTE

Perform the following when removing both or left side frame only.

- Battery box removed (see TM 5-2420-222-20).

NOTE

Perform the following when removing both or right side frame

- Hydraulic oil filter relief valve removed (see TM 5-2420-222-20).
- Toolbox removed (see TM 5-2420-222-20).

Materials/Parts:

- Rags (Item 28, Appendix B)
- Dry cleaning solvent (Item 31, Appendix B)
- One lockwasher

Tools/Test Equipment:

- General mechanic's tool kit
- Field automotive shop set

References:

- TM 5-2420-222-20
- TM 9-237

General Safety Instructions:

- Dry cleaning solvent is flammable and must not be used near open flame. Use only in a well-ventilated area.

NOTE

Both loader side frames are maintained the same way. Left side is shown. Repeat procedure for right side as required.

a. REMOVAL

WARNING

Use extreme caution when handling heavy parts. Lifting device is required when parts weigh over 50 lb (23 kg) for a single person lift, over 100 lb (45 kg) for a two person lift, and over 150 lb (68 kg) for a three or more person lift. Keep clear of heavy parts supported only by lifting device. Failure to follow this warning may cause serious injury or death to personnel.

1. Position two jackstands under transmission (2).

NOTE

If removing right side frame, skip step 2.

2. Remove screw (7), lockwasher (6), clamp (5), and bushing (4) from side frame (3) and three hydraulic hoses (8). Discard lockwasher.

15-6. LOADER SIDE FRAMES MAINTENANCE (Con't).

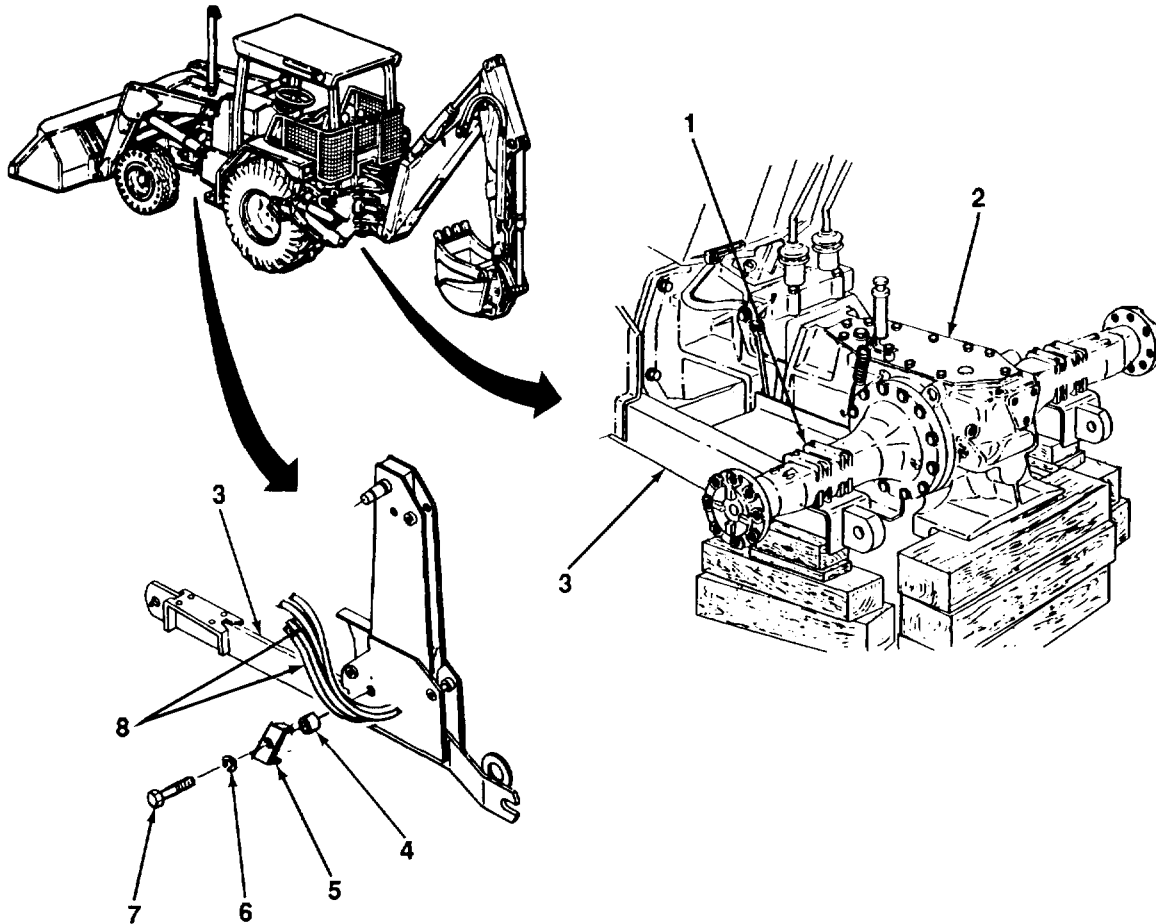

3. Using lifting device, support side frame (3).
4. Using hydraulic floor jack and wood blocks, lift rear axle housing (1) clear of side frame (3).
5. Using lifting device, raise side frame (3) clear of rear axle housing (1) and forward jackstand. Lower side frame to rest on wood blocks, and remove lifting device.
6. Position jackstand under rear axle housing (1). Lower hydraulic floor jack until rear axle housing rests on jackstand.

b. DISASSEMBLY

If damaged, remove identification and name plates (see TM 5-2420-222-20).

15-6. LOADER SIDE FRAMES MAINTENANCE (Con't).

c. CLEANING AND INSPECTION**WARNING**

Dry cleaning solvent, P-D-680, is toxic and flammable. Always wear protective goggles and gloves, and use only in a well-ventilated area. Avoid contact with skin, eyes, and clothes, and DO NOT breathe vapors. DO NOT use near open flame or excessive heat. The solvent's flash point is 100°F-138°F (38°C-59°C). If you become dizzy while using cleaning solvent, immediately get fresh air and medical help. If solvent contacts eyes, immediately wash your eyes and get medical aid.

1. Clean side frame and all other metal parts with dry cleaning solvent and rags. Dry thoroughly with clean, dry rags.
2. Inspect side frame and all other metal parts for cracks, breaks, abnormal bends, and damaged threads.

d. REPAIR

1. Restore damaged side frame (3) threads using screw threading set.
2. If cracks, breaks, or broken welds were found, repair by welding (see TM 9-237).

e. ASSEMBLY

If damaged, install identification and name plates (see TM 5-2420-222-20).

f. INSTALLATION**WARNING**

Use extreme caution when handling heavy parts. Lifting device is required when parts weigh over 50 lb (23 kg) for a single person lift, over 100 lb (45 kg) for a two person lift, and over 150 lb (68 kg) for a three or more person lift. Keep clear of heavy parts supported only by lifting device. Failure to follow this warning may cause serious injury or death to personnel.

1. Using hydraulic floor jack, raise rear axle housing (1) off jackstand, then remove jackstand.
2. Using lifting device, lift side frame (3) into position under rear axle housing (1) and support.
3. Using hydraulic floor jack, lower rear axle housing (1) onto side frame (3).
4. Remove lifting device from side frame (3).

NOTE

If installing right side frame, skip step 5.

5. Position three hydraulic hoses (8), clamp (5), and bushing (4) in place on side frame (3) Install screw (7) and new lockwasher (6) in clamp, bushing, and side frame.
6. Remove two jackstands from under transmission (2).

15-6. LOADER SIDE FRAMES MAINTENANCE (Con't).

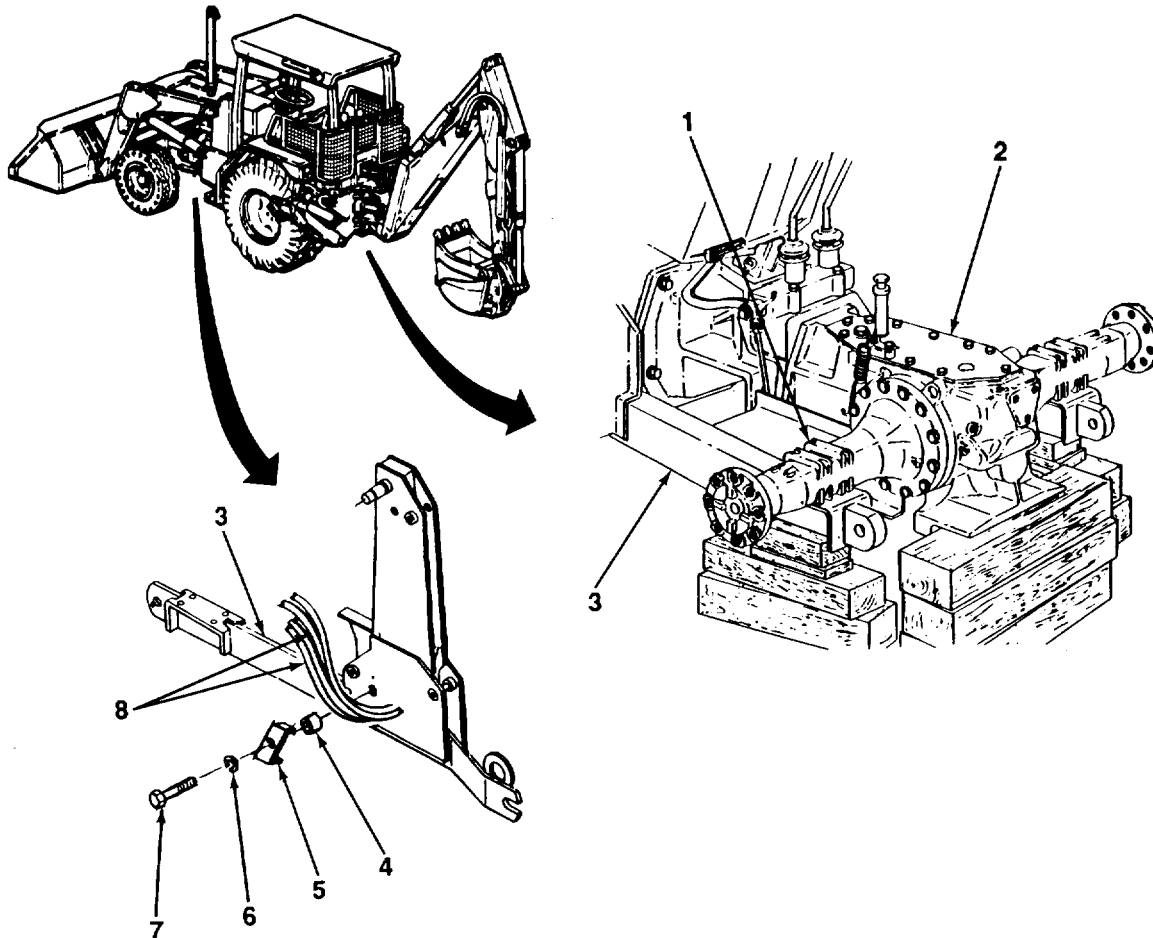

FOLLOW-ON TASKS

- Install roll-over protective structure (ROPS) or canopy rear mounts (see paragraph 13-4).
- Install frame assembly front support (see paragraph 12-1).
- Install loader lift arms (see paragraph 15-5).
- Install loader boom cylinders (see TM 5-2420-222-20).

NOTE

Perform the following when installing both or left side frame only.

- Install battery box (see TM 5-2420-222-20).

NOTE

Perform the following when installing both or right side frame only.

- Install hydraulic oil filter relief valve (see TM 5-2420-222-20).
- Install toolbox (see TM 5-2420-222-20).

CHAPTER 16
PARTS PECULIAR MAINTENANCE

Paragraph Number	Paragraph Title	Page Number
16-1	Hydraulic Earth Drill Boring Head Motor Replacement.....	16-1
16-2	Hydraulic Earth Drill Boring Head Motor Repair	16-6
16-3	Hydraulic Earth Drill Boring Head Repair.....	16-11
16-4	Hydraulic Impactor Motor Assembly Replacement.....	16-17
16-5	Hydraulic Impactor Repair	16-19

16-1. HYDRAULIC EARTH DRILL BORING HEAD MOTOR REPLACEMENT.

This Task Covers:

- a. Removal
- b. Installation

Initial Setup:

Equipment Conditions:

- Hydraulic earth drill boring head removed (see TM 5-2420-222-20).
- Hydraulic earth drill boring head chain case drained (see LO 5-2420-222-12).

Materials/Parts:

- Nonelectrical wire (Item 44, Appendix B)
- One cotter pin
- Two gaskets

Tools/Test Equipment:

- General mechanic's tool kit
- Field automotive shop set

Personnel Required: Two

16-1. HYDRAULIC EARTH DRILL BORING HEAD MOTOR REPLACEMENT (Con't).

a. REMOVAL

1. Remove 13 bolts (5), housing (4), and one gasket (3) from housing (2) and boring head (1). Discard gasket.
2. Loosen, but do not remove four nuts (6).

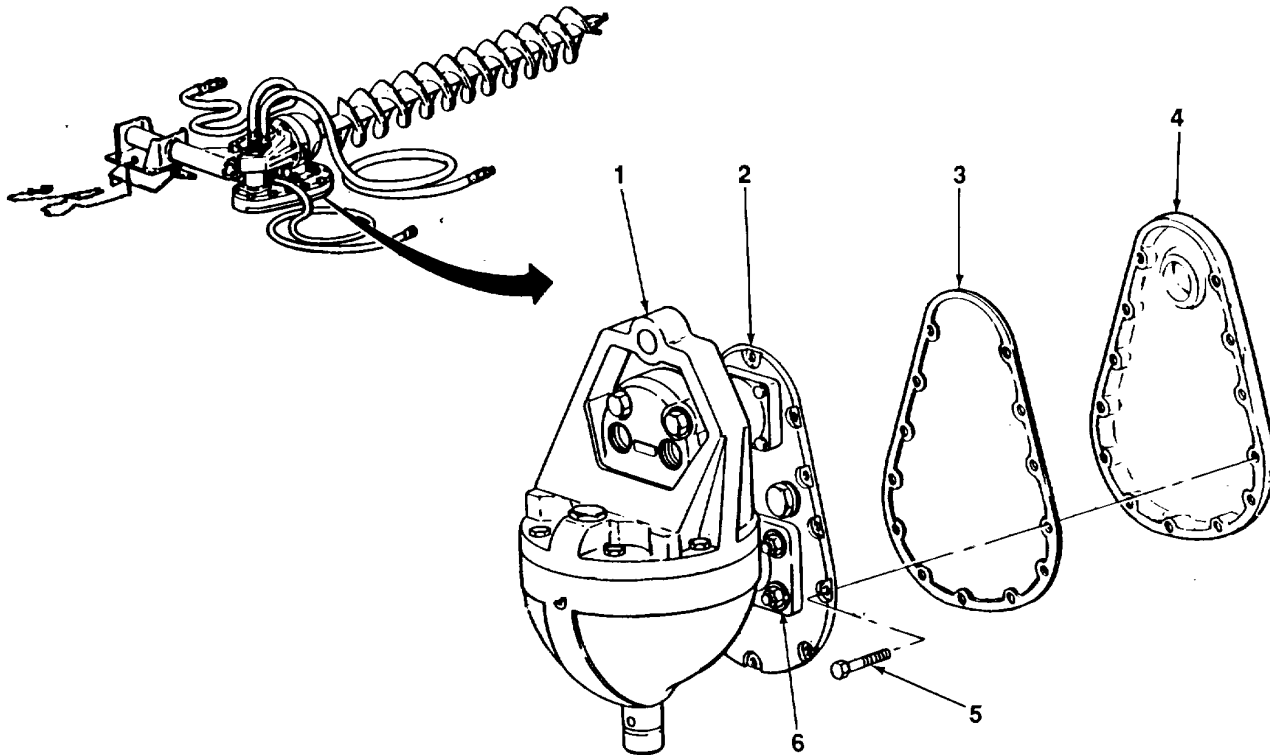

3. Cut lockwire (14) and remove four screws (9) from hub (13) and wheel sprocket (15). Discard lockwire.
4. Remove cotter pin (10), nut (11), and washer (12) from hub (13). Discard cotter pin.
5. Remove hub (13) and wheel sprocket (15).
6. Remove roller chain (7) from sprocket (8).

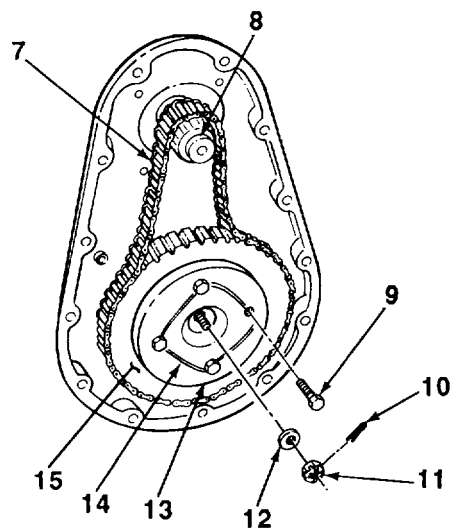

16-1. HYDRAULIC EARTH DRILL BORING HEAD MOTOR REPLACEMENT (Con't).

- 7. Match-mark motor (16) and housing (2) to ensure proper installation. (21).
- 8. Remove four nuts (18), motor (16), and gasket (17) from housing (2), Discard gasket.

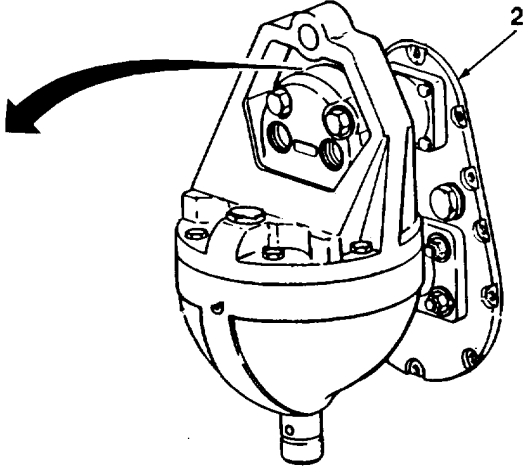
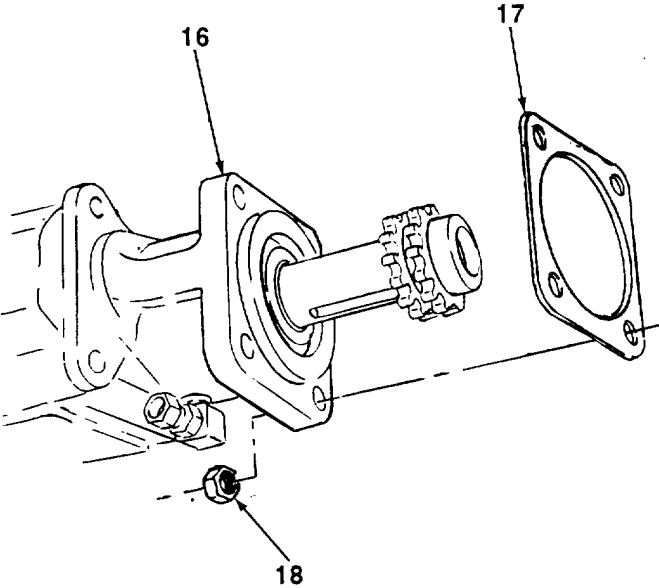

- 9. Remove setscrew (19) and sprocket (8) from shaft (21).
- 10. Remove key (20) from shaft (21).

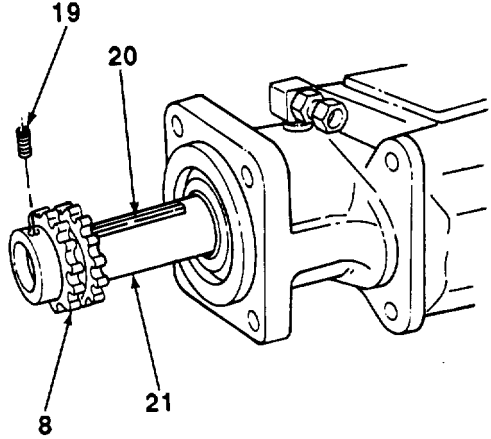

b. INSTALLATION

- 1. Install key (20) on shaft (21).
- 2. Install sprocket (8) over key (20) on shaft (21).
- 3. Install setscrew (19) in sprocket (8).
- 4. Place new gasket (17) over four studs on housing (2).
- 5. Aline match-marks and install motor (16) on studs in housing (2). Install four nuts (18) on studs to secure motor.

16-1 HYDRAULIC EARTH DRILL BORING HEAD MOTOR REPLACEMENT (Con't).

6. Install roller chain (7) on sprocket (8).

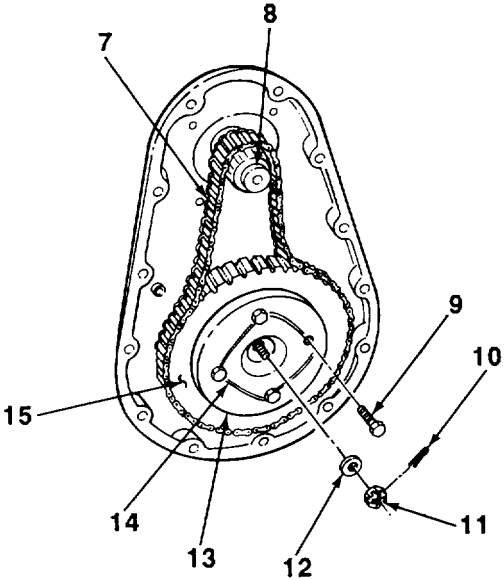

7. Loosen, but do not remove four nuts (6) securing boring head (1) to housing (2).

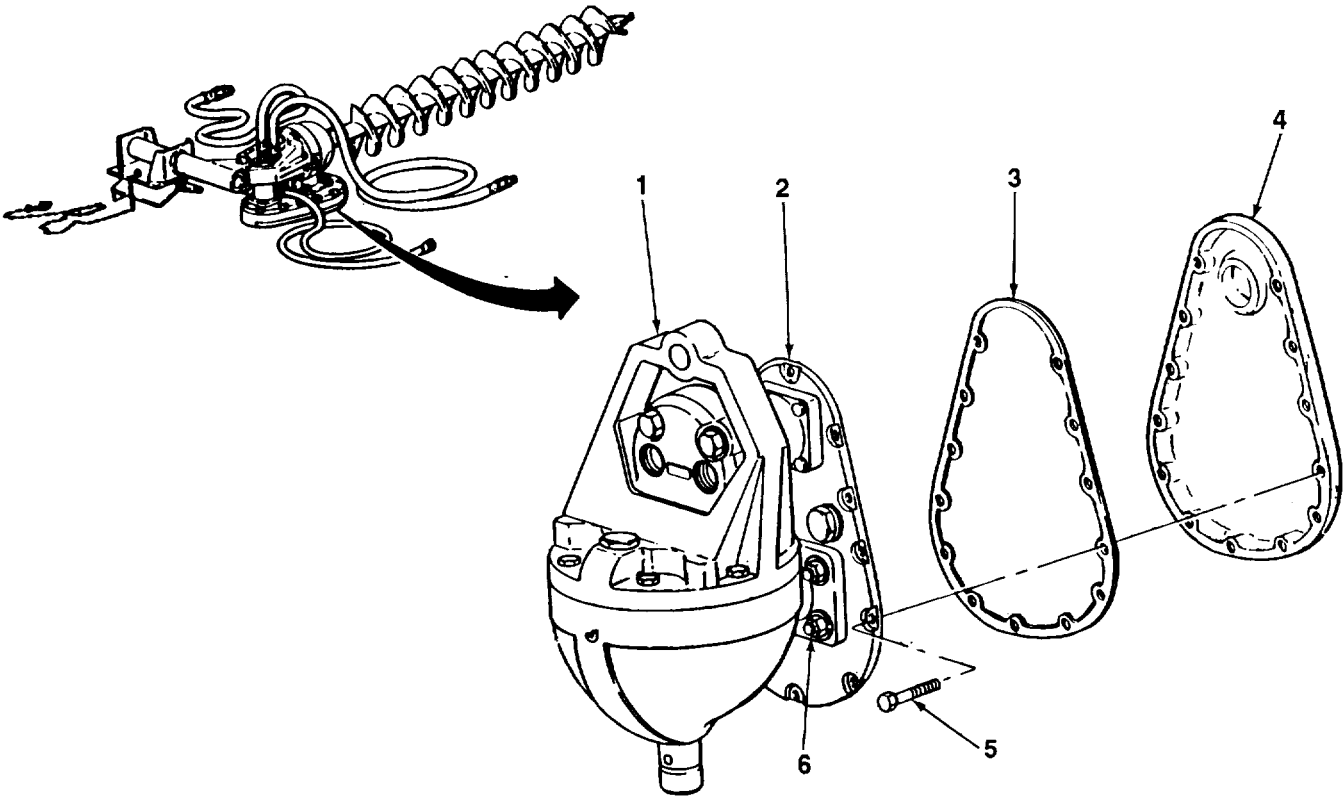

TA701658

16-1 HYDRAULIC EARTH DRILL BORING HEAD MOTOR REPLACEMENT (Con't).

8. Position wheel sprocket (15) and hub (13) in place and install roller chain (7) on wheel sprocket.
9. Secure wheel sprocket (15) and hub (13) with washer (12), nut (11), and new cotter pin (10).
10. Install four screws (9) in hub (13) and wheel sprocket (15). Secure screws with lockwire (14) (see paragraph 1-28).
11. With the aid of an assistant, slide housing (2) on boring head (1).
12. While assistant supports housing (2) in place, tighten four nuts (6).
13. Install new gasket (3) and housing (4) on housing (2) and boring head (1) with 13 bolts (5).

FOLLOW-ON TASKS:

- Fill hydraulic earth drill boring head (see LO 5-2420-222-12).
- Install hydraulic earth drill boring head (see TM 5-2420-222-20).

16-2. HYDRAULIC EARTH DRILL BORING HEAD MOTOR REPAIR.

This Task Covers:

- | | |
|----------------------------|-------------|
| a. Disassembly | c. Repair |
| b. Cleaning and Inspection | d. Assembly |

Initial Setup:

Equipment Conditions:

- Hydraulic earth drill boring head motor removed (see paragraph 16-1).

Tools/Test Equipment:

- General mechanic's tool kit
- Field automotive shop set

Materials/Parts:

- Rags (Item 28, Appendix B)
- Dry cleaning solvent (Item 31, Appendix B)
- Two preformed packings

General Safety Instructions:

- Dry cleaning solvent is flammable and must not be used near open flame. Use only in a well-ventilated area.

a. DISASSEMBLY

NOTE

Match-mark housings to ensure proper assembly of hydraulic earth drill boring head motor.

- Remove four bolts (7) and washers (6) from top housing (5).

NOTE

Six keys may fall out when removing top housing.

- Remove top housing (5) from center housing (1). Remove six keys (4) from spacer (3).
- Remove preformed packing (9) from center housing (1). Discard preformed packing.

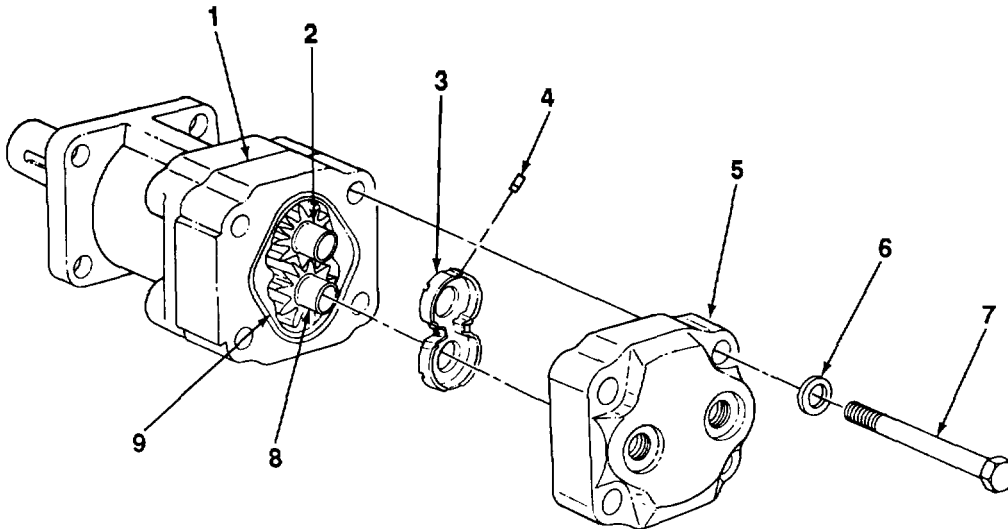

16-2 HYDRAULIC EARTH DRILL BORING HEAD MOTOR REPAIR (Con't).

4. Remove spacer (3) from center housing (1).
5. Remove gears (2 and 8) from center housing (1).

CAUTION

Perform step 6 only if roller bearings are damaged. Removal may damage parts.

6. Using mechanical gear and bearing puller, remove two roller bearings (10 and 11) from top housing (5).

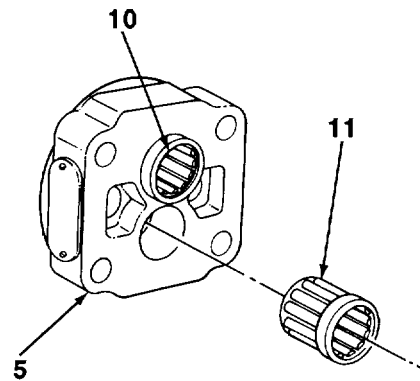

NOTE

Six keys may fall out when removing center housing.

7. Remove center housing (1) from rear housing (14).
8. Remove six keys (16) and spacer (17) from center housing (1).
9. Remove preformed packing (18) from center housing (1). Discard preformed packing.
10. Position rear housing (14) in vise.

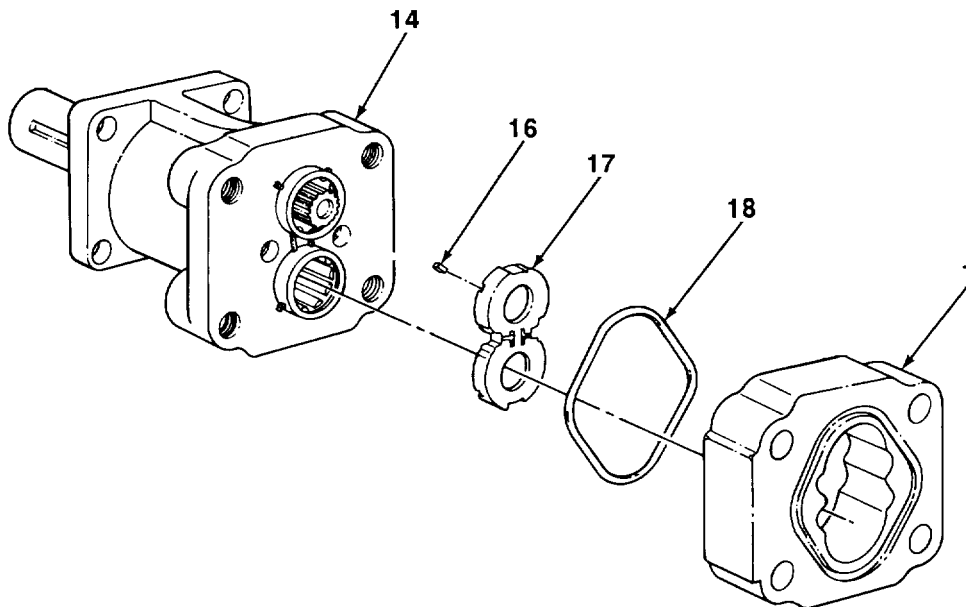

16-2 HYDRAULIC EARTH DRILL BORING HEAD MOTOR REPAIR (Con't).

11. Remove collar (12) from rear housing (14).
12. Tap shaft (13) assembly out of rear housing (14).

CAUTION

Perform step 13 only if roller bearings are damaged. Removal may damage parts.

13. Using mechanical gear and bearing puller, remove two roller bearings (19 and 20) from rear housing (14).
14. Remove spacer (21) from rear housing (14).
15. Remove two check valves (15) from rear housing (14). Remove rear housing from vise.

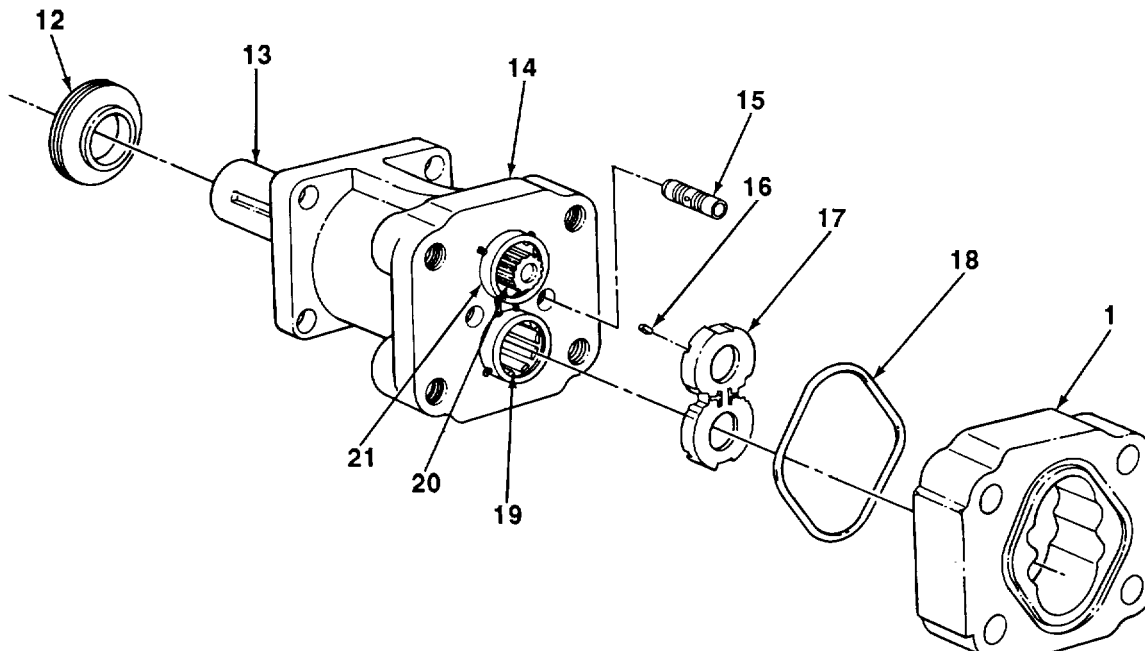

CAUTION

Perform steps 16 and 17 only if shaft bearings are damaged. Removal may damage parts.

16. Remove retaining ring (22) and spacer (23) from shaft (13).
17. Using mechanical gear and bearing puller, remove two bearing races (24), cones (25), and spacer (26) from shaft (13).

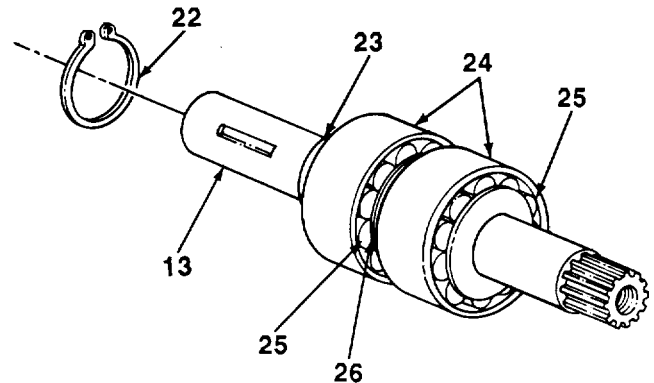

16-2 HYDRAULIC EARTH DRILL BORING HEAD MOTOR REPAIR (Con't).

b. CLEANING AND INSPECTION**WARNING**

Dry cleaning solvent, P-D-680, is toxic and flammable. Always wear protective goggles and gloves, and use only in a well-ventilated area. Avoid contact with skin, eyes, and clothes, and DO NOT breathe vapors. DO NOT use near open flame or excessive heat. The solvent's flash point is 100°F-138°F (38°C-59°C). If you become dizzy while using cleaning solvent, immediately get fresh air and medical help. If solvent contacts eyes, immediately wash your eyes and get medical aid.

1. Clean all metal parts with dry cleaning solvent. Dry thoroughly with clean, dry rags.
2. Inspect metal parts for cracks, breaks, or bends.
3. Inspect all threaded parts for damaged or stripped threads.

c. REPAIR

Restore damaged threads using screw threading set.

d. ASSEMBLY**NOTE**

Perform steps 1 through 3 only if roller bearings and shaft bearings were removed.

1. Using hammer and brass drift, install two bearing races (24), cones (25), and spacer (26) on shaft (13).
2. Install spacer (23) and retaining ring (22) on shaft (13).
3. Using hammer and brass drift, install two roller bearings (19 and 20) in rear housing (14).
4. Position rear housing (14) in vise. Install two check valves (15) in rear housing.
5. Install spacer (21) in rear housing (14).
6. Tap shaft (13) assembly in rear housing (14).
7. Install collar (12) on shaft (13) assembly and rear housing (14). Stake collar in place.
8. Remove rear housing (14) from vise.
9. Install new preformed packing (18) in center housing (1).
10. Install spacer (17) and six keys (16) on center housing (1).
11. Install center housing (1) and assembled parts on rear housing (14).

16-2 HYDRAULIC EARTH DRILL BORING HEAD MOTOR REPAIR (Con't).

12. Install gears (2 and 8) in center housing (1).
13. Install spacer (3) and new preformed packing (9) on center housing (1).
14. Install six keys (4) in spacer (3) and center housing (1).

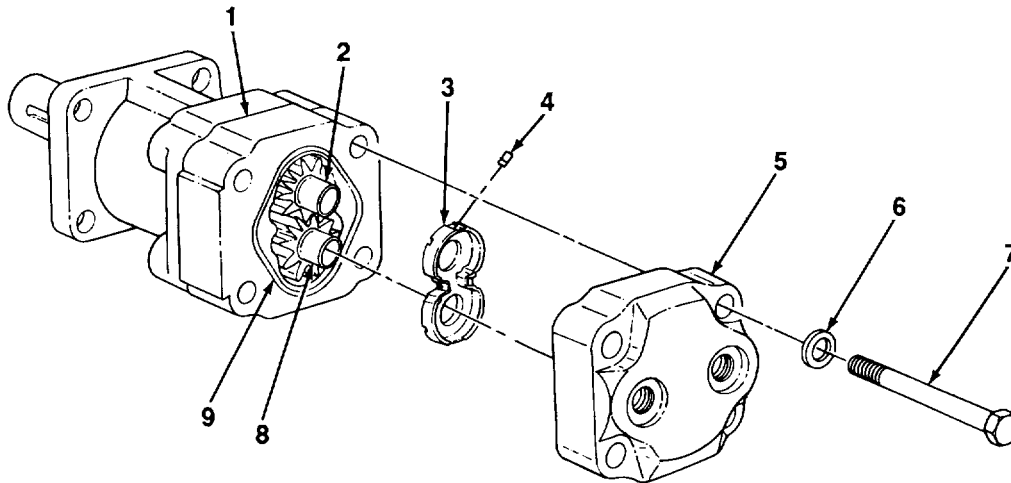

NOTE

Perform step 15 only if roller bearings were removed.

15. Using hammer and brass drift, install two roller bearings (10 and 11) in top housing (5).

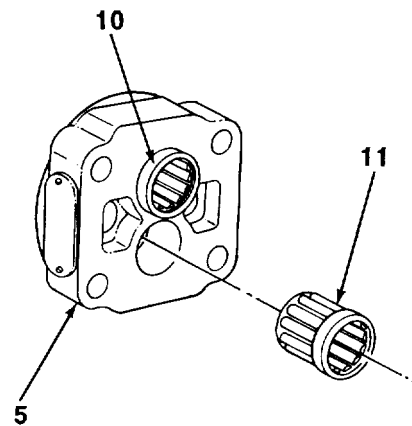

16. Position top housing (5) in place on center housing (1).
17. Install four bolts (7) and washers (6) in top housing (5).

FOLLOW-ON TASKS:

- Install hydraulic earth drill boring head motor (see paragraph 16-1).

16-3. HYDRAULIC EARTH DRILL BORING HEAD REPAIR.

This Task Covers:

- | | |
|----------------------------|-------------|
| a. Disassembly | c. Repair |
| b. Cleaning and Inspection | d. Assembly |

Initial Setup:

Equipment Conditions:

- Hydraulic earth drill boring head motor removed (see paragraph 16-1).

Tools/Test Equipment:

- General mechanic's tool kit
- Field automotive shop set

References:

- TM 9-214

General Safety Instructions:

- Materials/Parts:**
- Hydraulic fluid (Item 15, Appendix B)
 - Grease (Item 22, Appendix B)
 - Rags (Item 28, Appendix B)
 - Dry cleaning solvent (Item 31, Appendix B)
 - Nonelectrical wire (Item 44, Appendix B)
 - Two seals
 - Gaskets (as required)

- Dry cleaning solvent is flammable and must not be used near open flame. Use only in a well-ventilated area.

a. DISASSEMBLY

- Remove four nuts (6), washers (5), housing (3), and gasket (4) from housing (7) and cover (1). Discard gasket.
- Remove two screws (2) from housing (7) and cover (1).

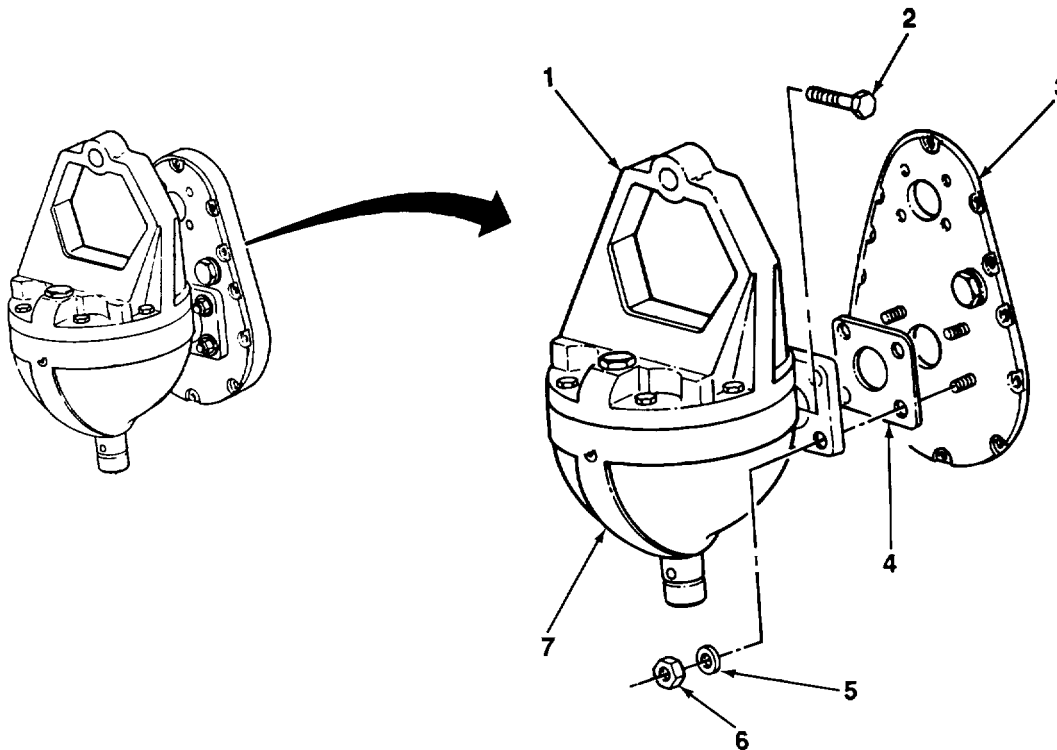

TA701663

16-3 HYDRAULIC EARTH DRILL BORING HEAD REPAIR (Con't).

- 3. Remove eight bolts (8) from housing (7) and cover (1).
- 4. Remove cover (1) and gaskets (9) from housing (7).
- 5. Using micrometer calipers, measure thickness of each gasket (9). Record quantity and size of each gasket to ensure proper assembly. Discard gaskets.
- 6. Remove shaft (10) with assembled parts from housing (7).
- 7. Using arbor press, remove cup (11) and cone (12) from shaft (10). Remove cone from cup.
- 8. Cut and remove lockwire (13) from 12 bolts (17). Discard lockwire.
- 9. Remove 12 bolts (17) from ring gear (16).
- 10. Using arbor press, remove ring gear (16), cup (14), and cone (15) from shaft (10). Remove cone from cup

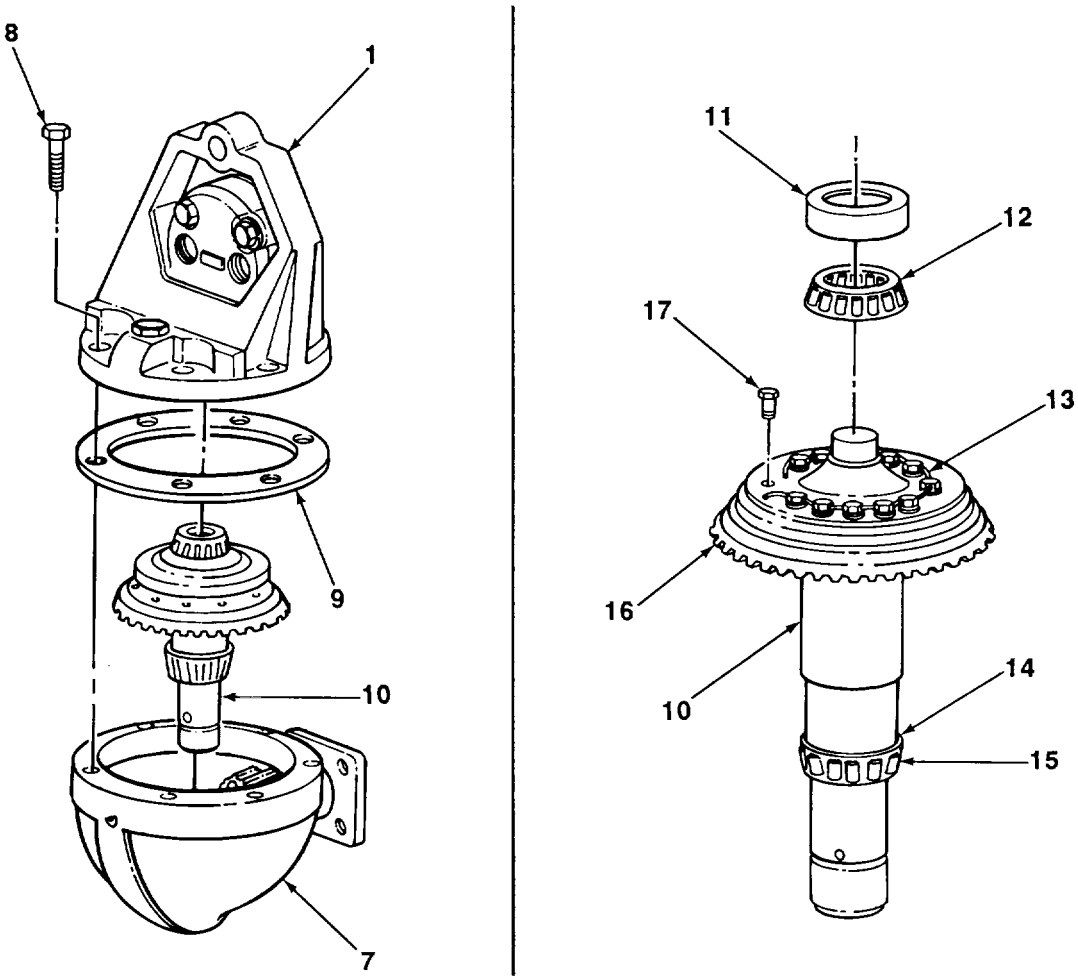

16-3 HYDRAULIC EARTH DRILL BORING HEAD REPAIR (Con't).

11. Remove seal (25) from housing (7). Discard seal.
12. Using arbor press, remove shaft (19) from housing (7).
13. Using arbor press, remove pinion (18), cup (21), and cone (20) from shaft (19). Remove cone from cup.
14. Remove spacer (22) and shims (23) from shaft (19). Note quantity of shims for proper placement during assembly.
15. Remove seal (24) from housing (7). Discard seal.

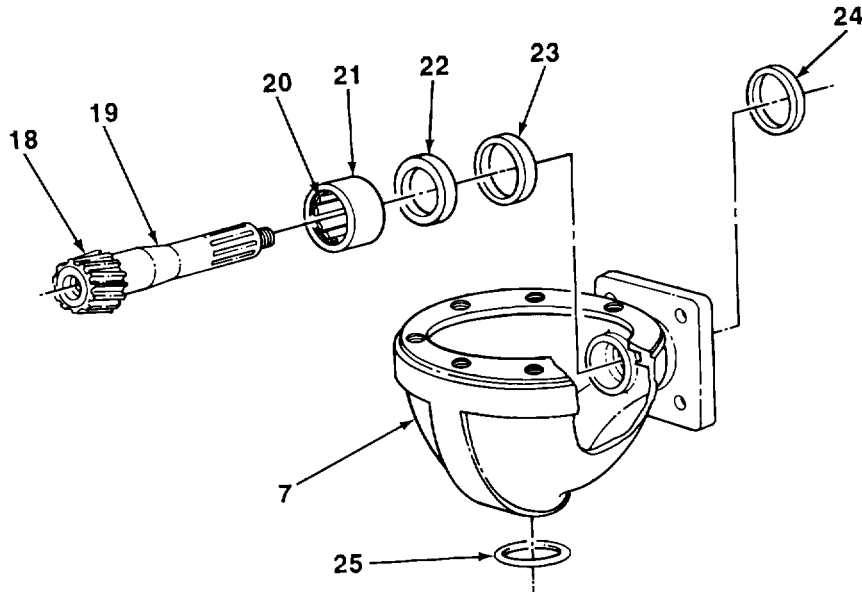
**b. CLEANING AND INSPECTION****WARNING**

Dry cleaning solvent, P-D-680, is toxic and flammable. Always wear protective goggles and gloves, and use only in a well-ventilated area. Avoid contact with skin, eyes, and clothes, and DO NOT breathe vapors. DO NOT use near open flame or excessive heat. The solvent's flash point is 100°F-138°F (38°C-59°C). If you become dizzy while using cleaning solvent, immediately get fresh air and medical help. If solvent contacts eyes, immediately wash your eyes and get medical aid.

1. Clean housing and cover with dry cleaning solvent and clean rags. Dry thoroughly with clean, dry rags.
2. Clean all other metal parts with dry cleaning solvent. Dry thoroughly with clean, dry rags.
3. Inspect gears and pinion for cracks, breaks, and damaged teeth and splines.
4. Inspect all other metal parts for cracks, breaks, and abnormal bends.
5. Inspect all threaded parts for damaged threads.
6. Inspect cups and cones (see TM 9-214).

16-3 HYDRAULIC EARTH DRILL BORING HEAD REPAIR (Con't).**c. REPAIR**

Restore damaged threads using screw threading set.

d. ASSEMBLY

1. Using remover and installer and arbor press, install new seal (24) in housing (7).
2. Position same quantity of shims (23) as disassembled and spacer (22) in place on shaft (19).
3. Using arbor press, install shaft (19) in housing (7).
4. Install cone (20) in cup (21). Pack cone with grease. Using arbor press, install cup and cone on shaft (19).
5. Using arbor press, install pinion (18) on shaft (19).
6. Using remover and installer and arbor press, install new seal (25) in housing (7).

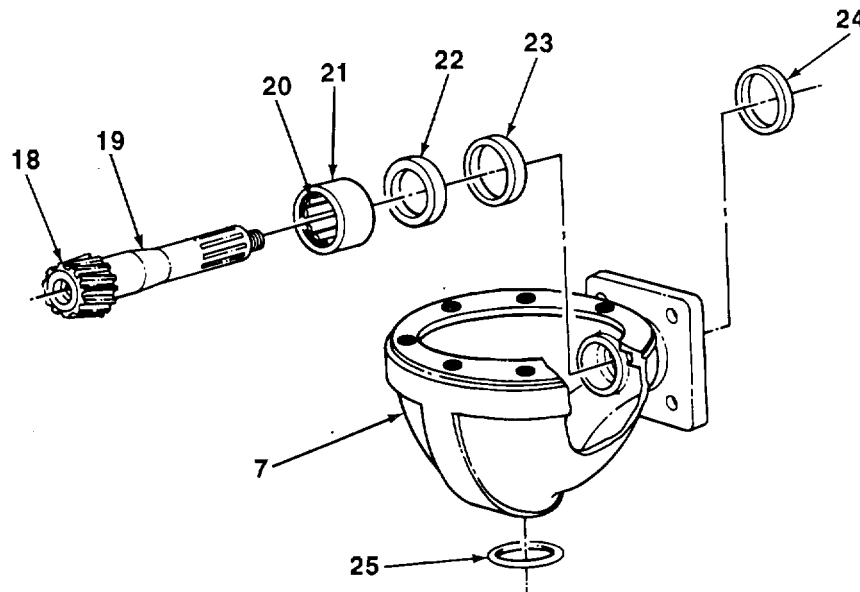

7. Install cone (15) in cup (14). Pack cone with grease. Using arbor press, install cup and cone on shaft (10).
8. Using arbor press, install ring gear (16) on shaft (10).
9. Install 12 bolts (17) in ring gear (16). Torque bolts to 40-45 lb.-ft. (54-61 N•m).
10. Install lockwire (13) on bolts (17) (see paragraph 1-28).
11. Install cone (12) in cup (11). Pack cone with grease. Using arbor press, install cup and cone on shaft (10).

16-3 HYDRAULIC EARTH DRILL BORING HEAD REPAIR (Con't).

- 12. Position shaft (10) with assembled parts in place in housing (7).
- 13. Install proper quantity and size of new gaskets (9) on housing (7).
- 14. Place cover (1) on housing (7). Install eight bolts (8) in cover and housing. Torque bolts to 50 lb.-ft. (68 N•m).

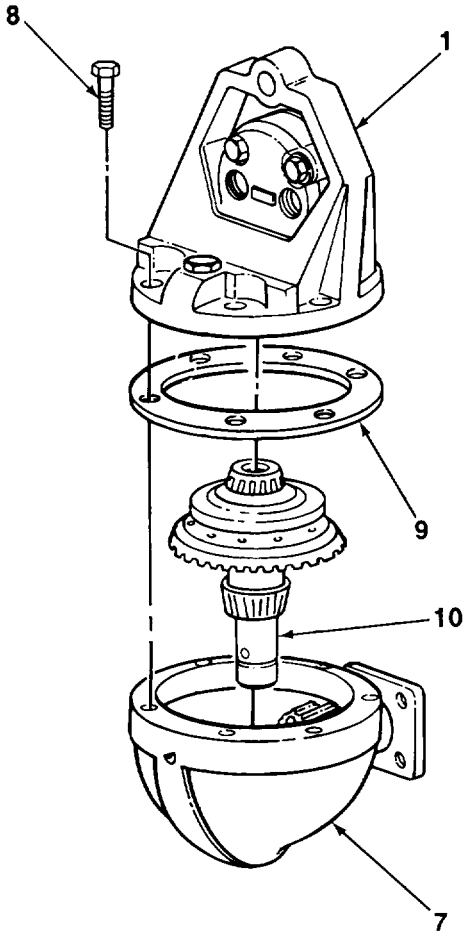
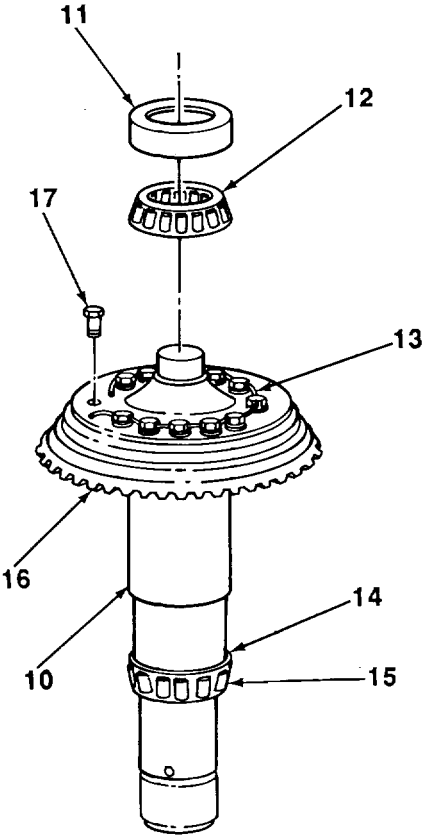

16-3 HYDRAULIC EARTH DRILL BORING HEAD REPAIR (Con't).

15. Install housing (3) and new gasket (4) on housing (7) and cover (1) with 4 nuts (6) and washers (5). Do not tighten nuts.
16. Install two screws (2) in housing (7) and cover (1). Torque screws to 35 lb.-ft. (47 N•m).

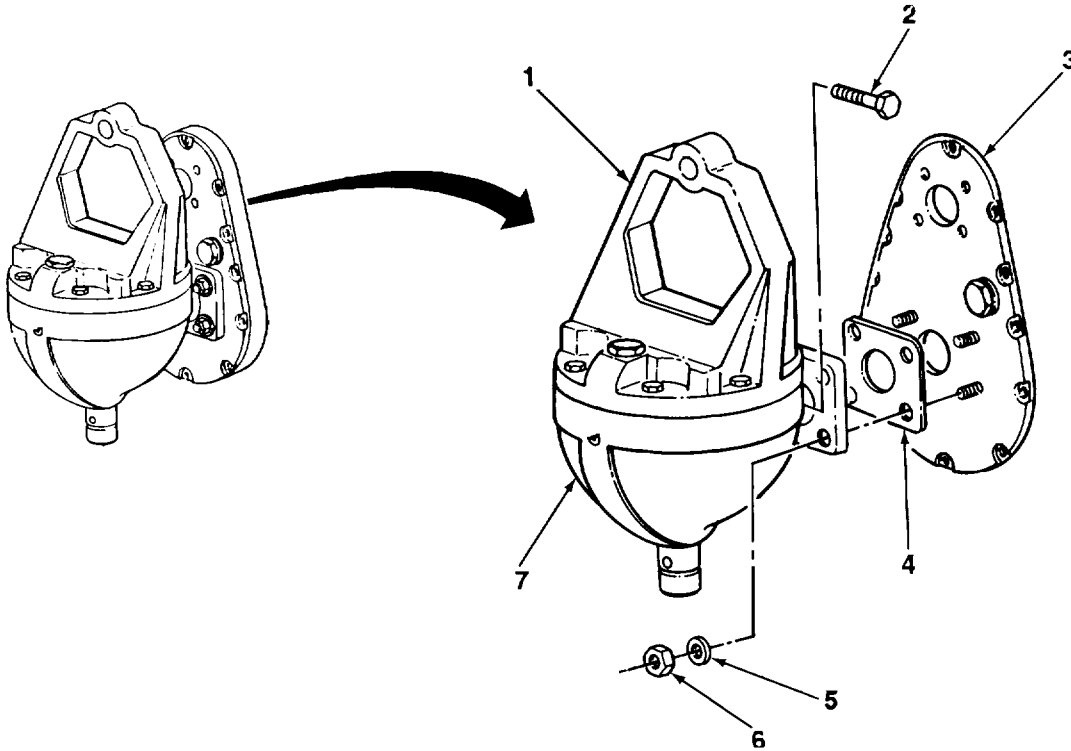
**FOLLOW-ON TASKS:**

- Install hydraulic earth drill boring head motor (see paragraph 16-1).

16-4. HYDRAULIC IMPACTOR MOTOR ASSEMBLY REPLACEMENT.

This Task Covers:

- | | | | |
|----|-------------------------|----|--------------|
| a. | Removal | c. | Installation |
| b. | Cleaning and Inspection | | |

Initial Setup:

Equipment Conditions:

- Hydraulic impactor lines and fittings removed (see TM 5 2420-222-20).

Materials/Parts:

- Rags (Item 28, Appendix B)
- Dry cleaning solvent (Item 31, Appendix B)
- Two seals

Tools/Test Equipment

- General mechanic's tool kit

General Safety Instructions:

- Dry cleaning solvent is flammable and must not be used near open flame. Use only in a well ventilated area.

a. REMOVAL

- Remove four screws (1) from rock drill bit (4) and hydraulic impactor (8).
- Remove seal (3), rock drill bit (4), retaining plate (5), and seal (6) from hydraulic impactor (8). Discard seals.
- If damaged, remove four bushings (2) and studs (7).

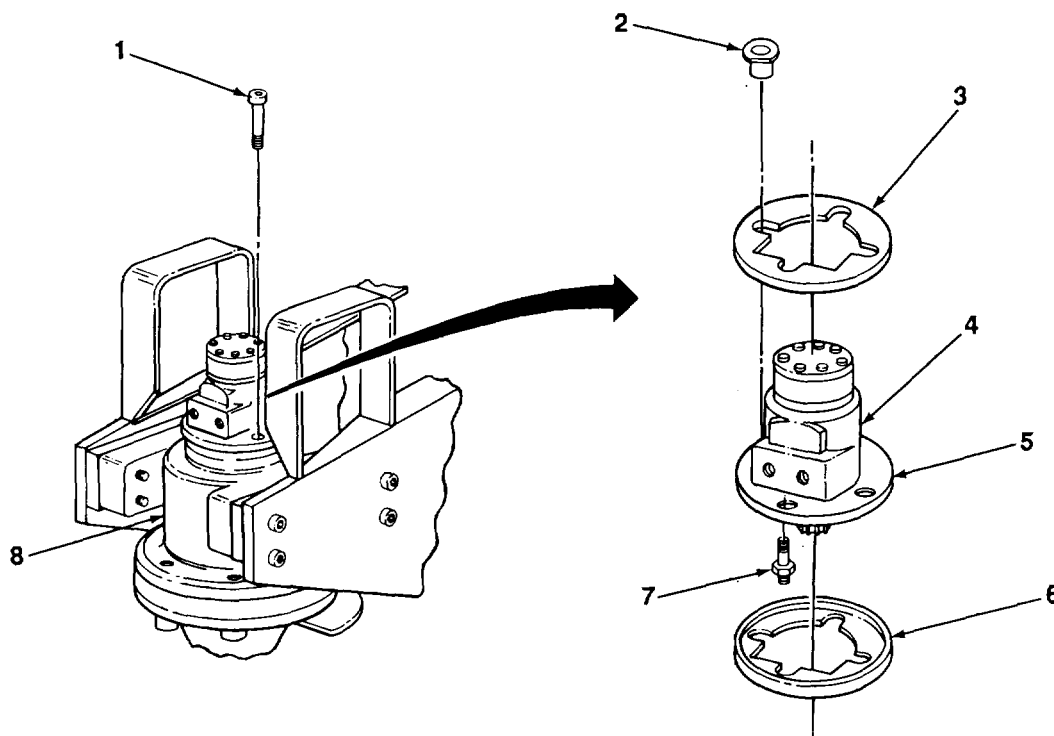

16-4. HYDRAULIC IMPACTOR MOTOR ASSEMBLY REPLACEMENT (Con't).

b. CLEANING AND INSPECTION**WARNING**

Dry cleaning solvent, P-D-680, is toxic and flammable. Always wear protective goggles and gloves, and use only in a well-ventilated area. Avoid contact with skin, eyes, and clothes, and DO NOT breathe vapors. DO NOT use near open flame or excessive heat. The solvent's flash point is 100°F-138°F (38°C-59°C). If you become dizzy while using cleaning solvent, Immediately get fresh air and medical help. If solvent contacts eyes, Immediately wash your eyes and get medical aid.

1. Clean rock drill bit and all metal parts with dry cleaning solvent. Dry thoroughly with clean, dry rags.
2. Inspect all metal parts for cracks, breaks, and bends.
3. Inspect all threaded parts for damage.

c. INSTALLATION

1. If removed, install four bushings (2) and studs (7).
2. Aline new seal (6), retaining plate (5), rock drill bit (4), and new seal (3) with mounting holes in hydraulic impactor (8).
3. Install four screws (1) in bushings (2).

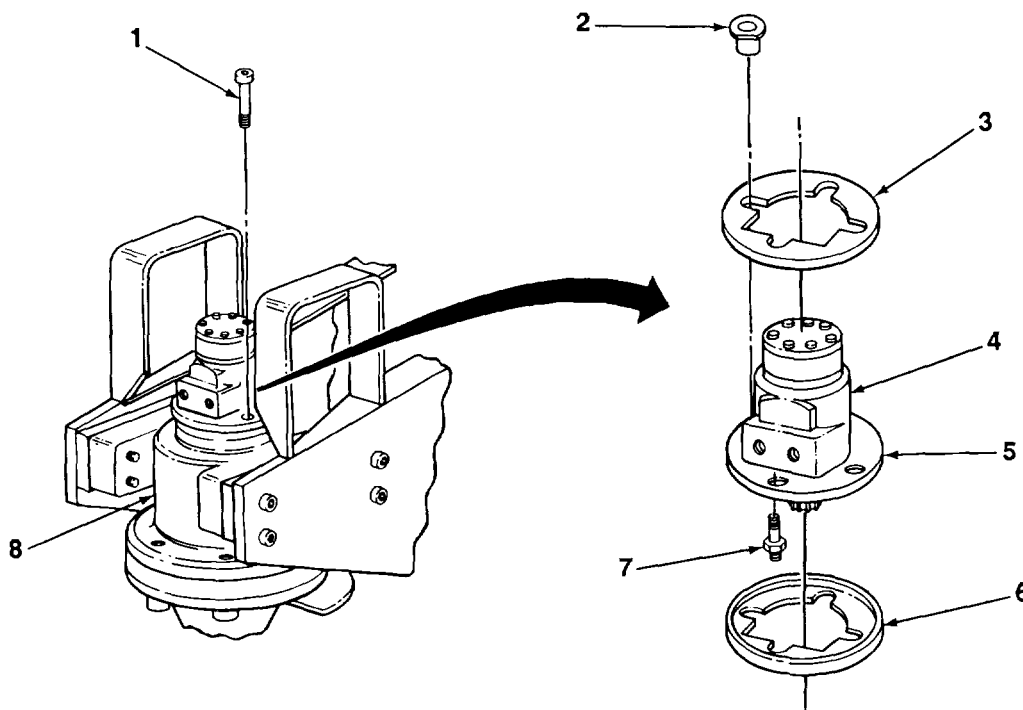
**FOLLOW-ON TASKS:**

- Install hydraulic impactor lines and fittings (see TM 5-2420-222-20).

16-5. HYDRAULIC IMPACTOR REPAIR.*This Task Covers:*

- | | |
|----------------------------|-------------|
| a. Disassembly | c. Assembly |
| b. Cleaning and Inspection | |

*Initial Setup:***Equipment Conditions:**

- Hydraulic impactor working tool removed (see TM 5-2420-222-20).
- Hydraulic impactor motor assembly removed (see paragraph 16-4).

Tools/Test Equipment:

- General mechanic's tool kit
- Field automotive shop set
- Ball retainer tool
- Spring compression tool (see Appendix C)

Materials/Parts:

- Impactor lubricant (Item 24, Appendix B)
- Rags (Item 28, Appendix B)
- Dry cleaning solvent (Item 31, Appendix B)
- One repair kit

Personnel Required: Two**General Safety Instructions:**

- Dry cleaning solvent is flammable and must not be used near open flame. Use only in a well-ventilated area.

a. DISASSEMBLY**WARNING**

Internal spring is under very high tension. Use a suitable holding device to hold both housings together when removing screws. Failure to follow this warning may result in injury or death to personnel.

1. Place hydraulic impactor in arbor press. Loosen six screws (2) about 1/8 in. (3.2 mm).
2. Relieve pressure on arbor press approximately 3/8 in. (9.5 mm). Shake lower housing (1) until lower housing becomes free of upper housing (3). Remove six screws (2) and go to step 4. If lower housing does not shake free, there may be an internal binding problem. Perform step 3.
3. Slowly release pressure on arbor press while loosening six screws (2) until screws are removed and tension is off lower housing (1).
4. Remove lower housing (1) from upper housing (3).

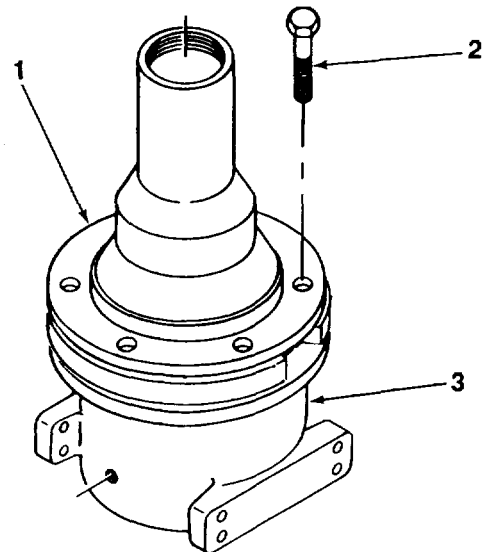

16-5. HYDRAULIC IMPACTOR REPAIR (Con't).

WARNING

Internal spring is under very high tension. Use extreme care when disassembling upper housing. Failure to follow this warning may result in injury or death to personnel.

- 5. Check that two guide blocks (7) are in position in guide ring (4) and two screws (8) are not damaged. If either screw is damaged, carefully remove damaged screw and insert a punch through guide ring to engage slot in striker (6).
- 6. Remove six screws (5) and carefully remove striker (6).
- 7. Remove preformed packing (9) from striker (6). Discard preformed packing.

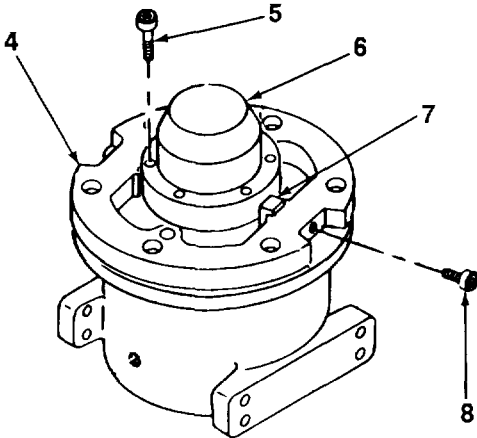

- 8. Position spring compression tool (10) over upper housing (3) so that two bushings (11) are visible in cutouts (12) of spring compression tool.
- 9. Position lower housing (1) on spring compression tool (10).

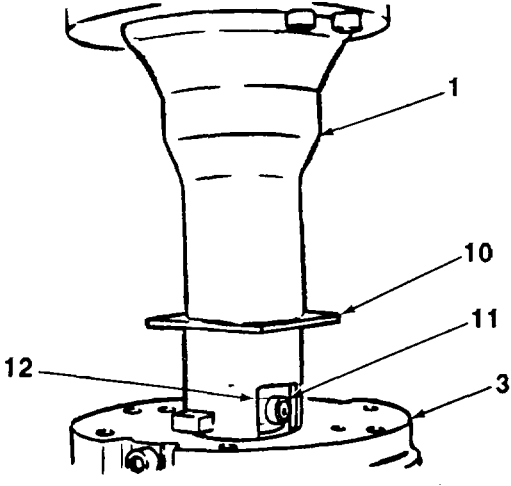
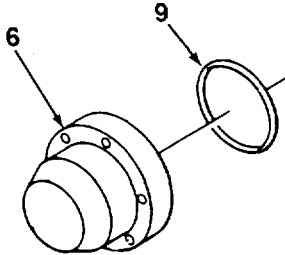

16-5. HYDRAULIC IMPACTOR REPAIR (Con't).**WARNING**

Internal spring is under very high tension. Use extreme care when disassembling upper housing. Failure to follow this warning may result in Injury or death to personnel.

10. Using arbor press, apply pressure to lower housing (1) until two bushings (11) on both sides of transport shaft (14) are visible.
11. Remove two bushings (11) from transport shaft (14). Remove transport shaft from shaft (13).
12. Remove two screws (16).

WARNING

Internal spring is under very high tension. Use extreme care when disassembling upper housing. Failure to follow this warning may result in Injury or death to personnel.

13. Slowly relieve pressure on arbor press until cam (18) is loose and pressure is off guide ring (4).

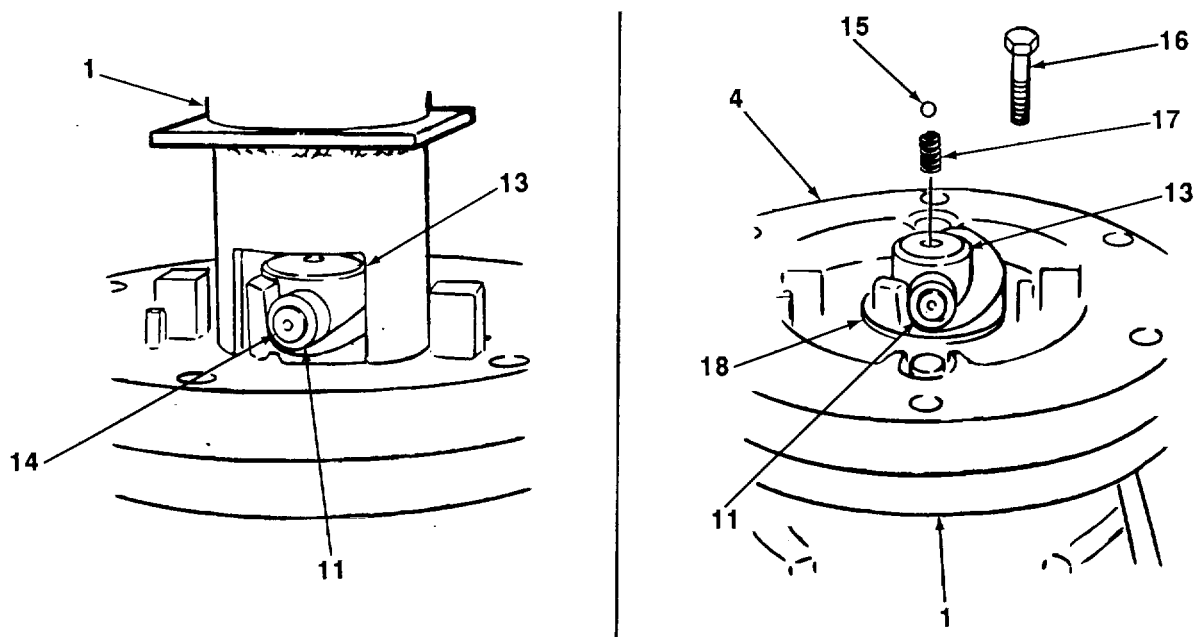

14. Remove lower housing (1) and spring compression tool (10) from upper housing (3).
15. Remove ball bearing (15) and spring (17) from shaft (13).

16-5. HYDRAULIC IMPACTOR REPAIR (Con't)

16. Remove upper housing (3) from arbor press.
17. Remove guide ring (4), cam (18), and spring (19) from upper housing (3).

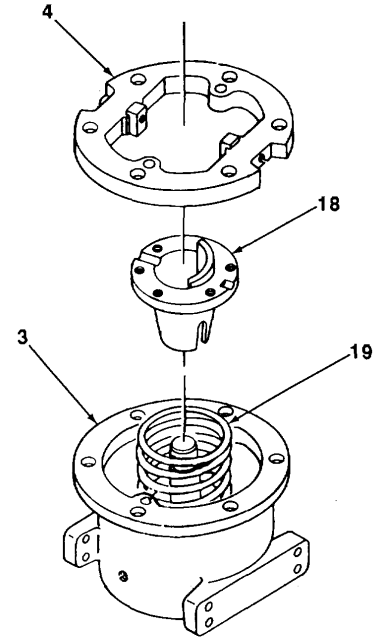

18. Remove preformed packing (20) from cam (18). Discard preformed packing.

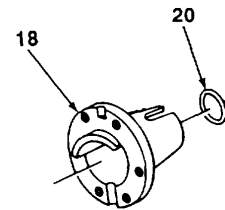

16-5. HYDRAULIC IMPACTOR REPAIR (Con't).

19. Remove two screws (8) and guide blocks (7) from guide ring (4).

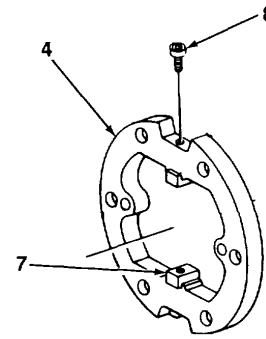

20. Remove four screws (24) and retainer (25).

21. Remove preformed packings (22 and 23) from retainer (25). Discard preformed packings.

22. Pull shaft (13) from upper housing (3).

23. Remove bearing washer (21) from upper housing (3).

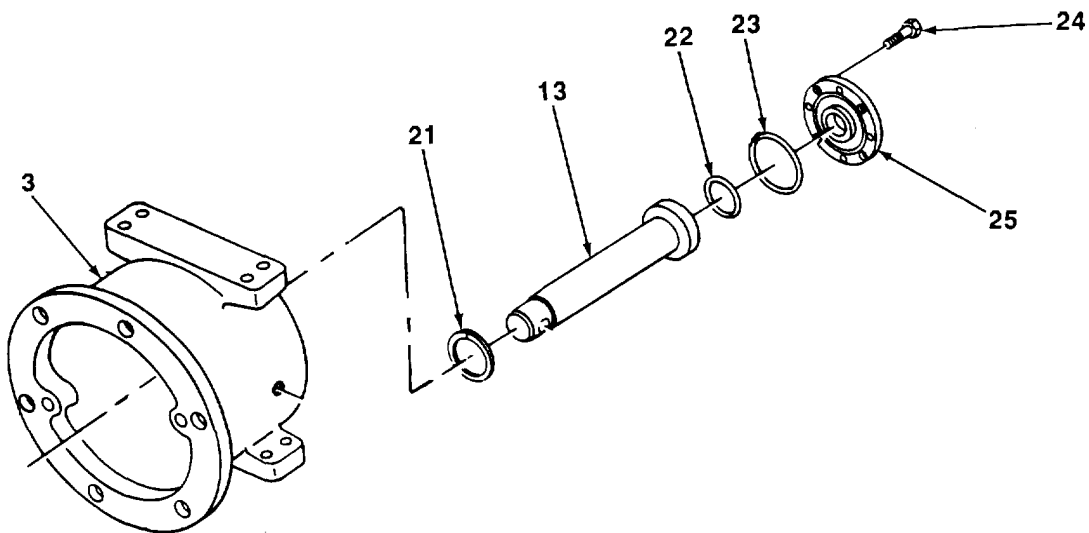

16-5. HYDRAULIC IMPACTOR REPAIR (Con't).

- 24. Remove bearing (29) and spacer (28) from top of upper housing (3). Discard bearing and spacer.
- 25. Remove retaining ring (34), seal (33), preformed packing (32), and bearing (31) from bottom of upper housing (3). Discard retaining ring, seal, preformed packing, and bearing.
- 26. Remove vent (26) and lubrication fitting (30).
- 27. If damaged, remove pin (27).

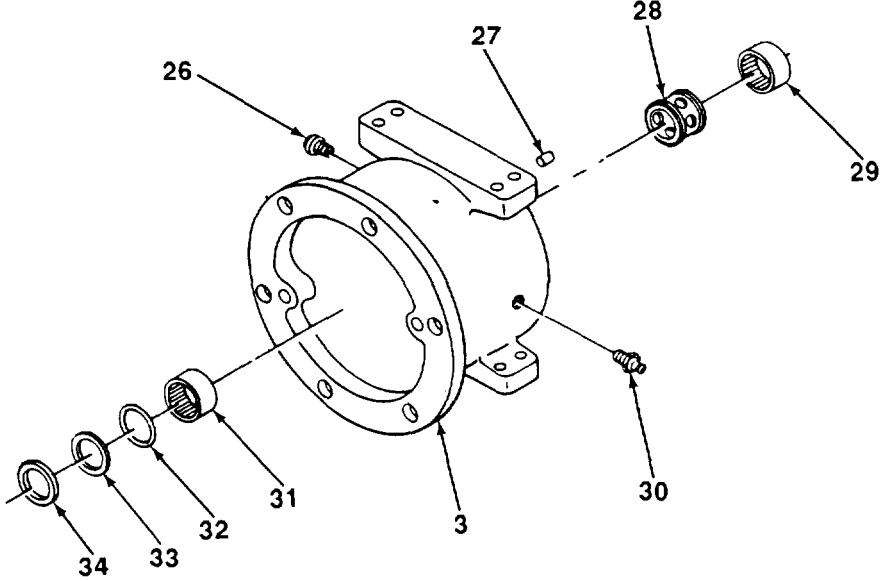

- 28. Remove retaining ring (35) and spacer (36) from lower housing (1).

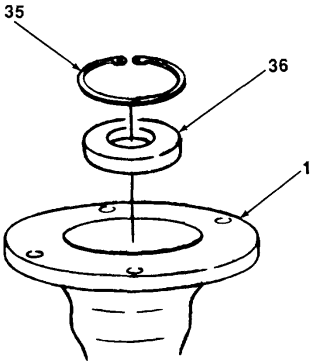

16-5. HYDRAULIC IMPACTOR REPAIR (Con't).**b. CLEANING AND INSPECTION****WARNING**

Dry cleaning solvent, P-D-680, is toxic and flammable. Always wear protective goggles and gloves, and use only in a well-ventilated area. Avoid contact with skin, eyes, and clothes, and DO NOT breathe vapors. DO NOT use near open flame or excessive heat. The solvent's flash point is 100°F-138°F (38°C-59°C). If you become dizzy while using cleaning solvent, immediately get fresh air and medical help. If solvent contacts eyes, immediately wash your eyes and get medical aid.

1. Clean all metal parts with dry cleaning solvent. Dry thoroughly with clean, dry rags.
2. Inspect housings for cracks, breaks, and damage. Replace if defective.

c. ASSEMBLY

1. If removed, install pin (27).
2. Install lubrication fitting (30) and vent (26).
3. Install new bearing (31) until seated 0.4375 in. (11.1125 mm) from bottom face of bearing bore.
4. Install new preformed packing (32), new seal (33), and new retaining ring (34).
5. Install new spacer (28) and new bearing (29) in top of upper housing (3).
6. Insert spring (17) in shaft (13).
7. Install ball bearing (15) on spring (17).
8. Install ball retainer tool (37) partway into shaft (13). Push down on ball bearing (15) and spring (17), and install ball retainer tool completely in shaft.

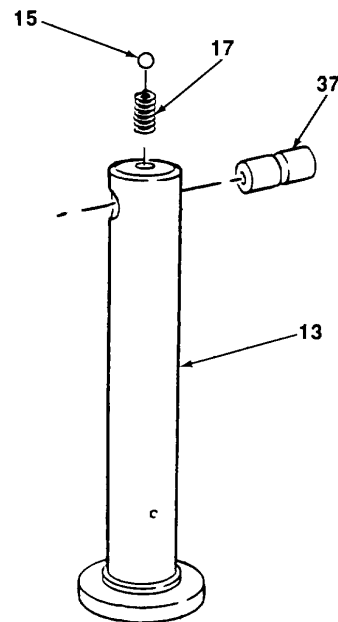

16-5. HYDRAULIC IMPACTOR REPAIR (Con't).

9. Install bearing washer (21) on upper housing (3).

NOTE

Ensure that shaft is installed through bearing washer, bearing, and spacer, and that bearing washer is seated on shaft.

10. Install shaft (13) through bearing washer (21) in upper housing (3). Ensure that shaft turns freely.

11. Install new preformed packings (22 and 23) in retainer (25).

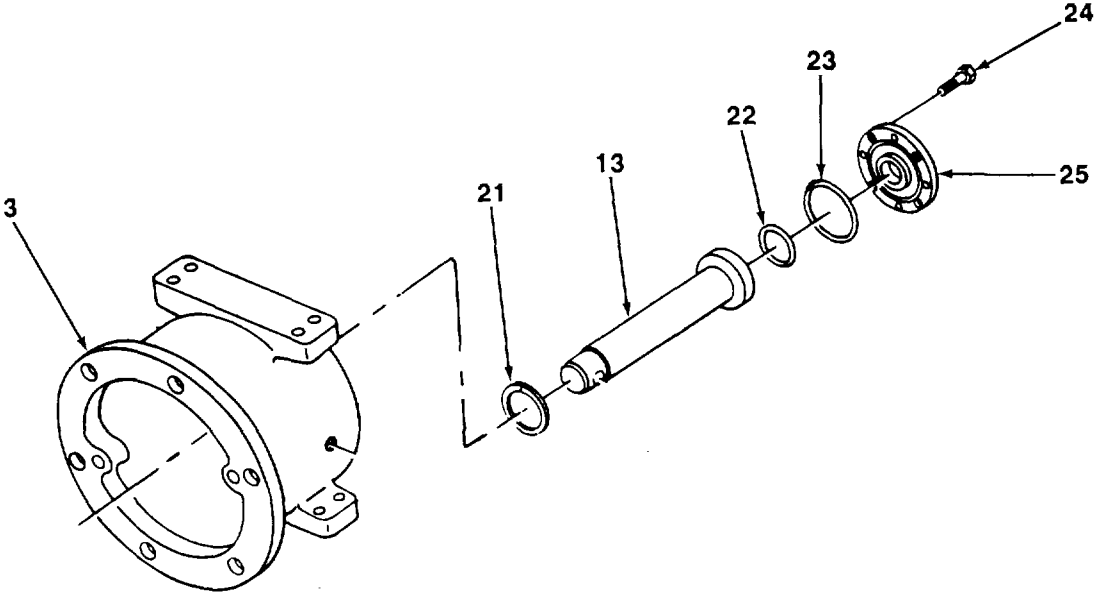

13. Install new preformed packing (20) in cam (18).

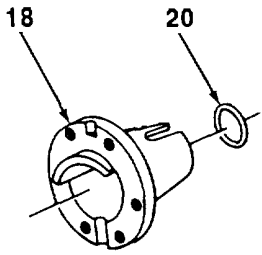

16-5. HYDRAULIC IMPACTOR REPAIR (Con't).

- 14. Install two guide blocks (7) on guide ring (4) with thick end of guide blocks toward guide ring screw holes.
- 15. Install two screws (8) through guide ring (4) and guide blocks (7). Torque screws to 225 lb.-ft. (305 N•m).

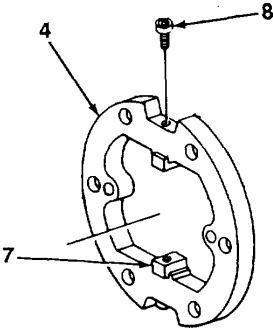

- 16. Place upper housing (3) on arbor press.
- 17. Place spring (19) in upper housing (3). Place cam (18) on spring.
- 18. Aline guide ring (4) on cam (18).

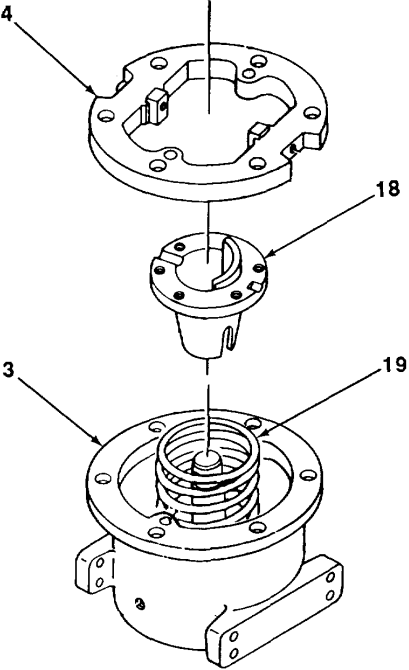

16-5. HYDRAULIC IMPACTOR REPAIR (Con't).

19. Aline cutouts (12) in spring compression tool (10) with two bushings (11) visible, and install spring compression tool over bushings.
20. Install lower housing (1) on spring compression tool (10).

WARNING

Internal spring is under very high tension. Use extreme care when assembling upper housing. Failure to follow this warning may result in Injury or death to personnel.

21. Ensure that cam (18) and shaft (13) are alined. Using arbor press, apply pressure until shaft is visible in cutouts (12) of spring compression tool (10).

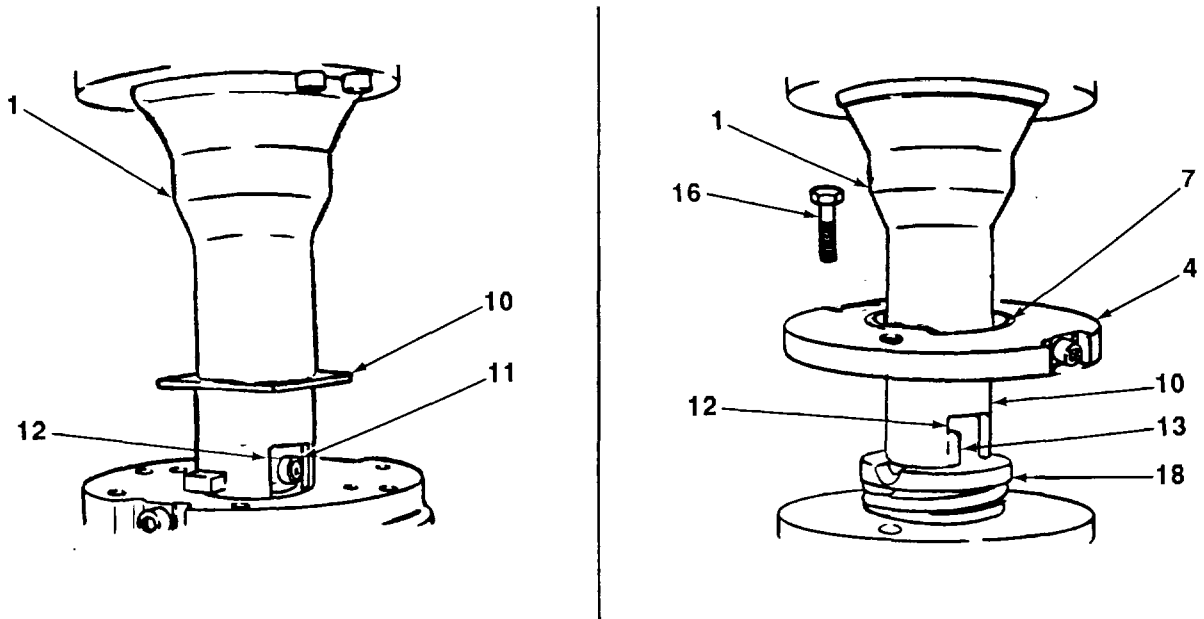
**NOTE**

- Apply pressure as required to ensure that hole in shaft is completely visible.
- Install transport shaft with detent up.

23. Install end of transport shaft (14) into hole of ball retainer tool. Push transport shaft in until centered and ball bearing drops into detent hole.
24. Remove ball retainer tool from transport shaft (14).

16-5. HYDRAULIC IMPACTOR REPAIR (Con't).

25. Slide two bushings (11) over ends of transport shaft (14).
26. Slowly release pressure on arbor press until bushings (11) come in contact with cam (18). Remove lower housing (1) and spring compression tool from arbor press.
27. Torque two screws (16) to 80 lb.-ft. (108 N•m).

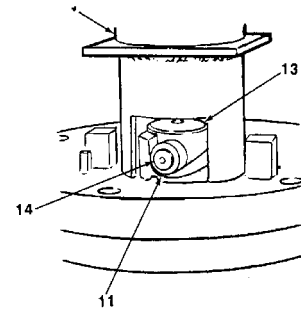

28. Fill striker (6) 1 1/4-1 1/2 in. (3.2-3.8 mm) from top with impactor lubricant.
29. Install new preformed packing (9) in striker (6).
30. Aline striker (6) with grooves in guide ring (4) and install six screws (5). Torque screws to 255 lb.-ft. (346 N•m).

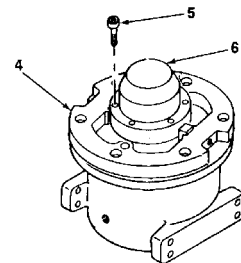
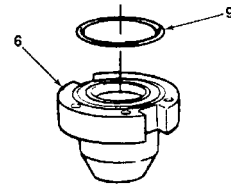

TA701681
16-29

16-5. HYDRAULIC IMPACTOR REPAIR (Con't).

31. Install spacer (36) in lower housing (1) with retaining ring (35).
32. Install lower housing (1) on upper housing (3) with six screws (2). Torque screws to 420 lb.-ft. (570 N•m).

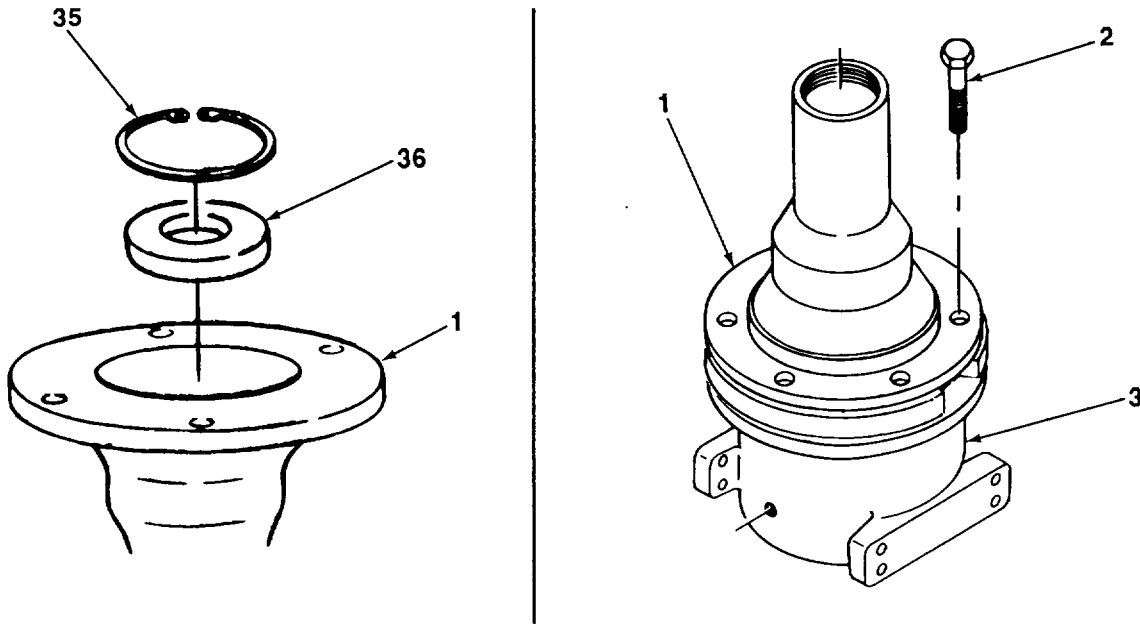
**FOLLOW-ON TASKS:**

- Install hydraulic impactor motor assembly (see paragraph 16-4).
- Install hydraulic impactor working tool (see TM 5-2420-222-20).

**APPENDIX A
REFERENCES**

A-1. SCOPE.

This appendix lists all forms, technical bulletins, technical manuals, and other publications referenced in this manual and which apply to the Direct Support and General Support Maintenance of the loader backhoe.

A-2. PUBLICATION INDEXES.

The following indexes should be consulted frequently for latest changes or revisions and for new publications relating to material covered in this technical manual.

Consolidated Index of Army Publications and Blank Forms	DA Pam 230
US Army Equipment Index of Modification Work Orders	DA Pam 750-10

A-3. FORMS.

Refer to DA Pam 738-750, The Army Maintenance Management System (TAMMS), for instructions on the use of maintenance forms.

Product Quality Deficiency Report.....	SF Form 368
Recommended Changes to Equipment Technical Publications	DA Form 2028-2
Recommended Changes to Publications and Blank Forms	DA Form 2028

A-4. LOADER BACKHOE PUBLICATIONS.

Direct Support and General Support Maintenance Repair Parts and Special Tools Lists for Tractor, Wheeled, DED, Loader Backhoe: with Hydraulic Impact Tool and with Hydraulic Earth Auger Attachment [John Deere Model JD410 (CCE)] with Bucket, Impactor, and Earth Drill, NSN 2420-00-567-0135	TM 5-2420-222-34P
Lubrication Order for Tractor, Wheeled, DED, Loader Backhoe: with Hydraulic Impact Tool and with Hydraulic Earth Auger Attachment [John Deere Model JD410 (CCE)] with Bucket, Impactor, and Earth Drill, NSN 2420-00-567-0135	LO 5-2420-222-12
Operator's Manual for Tractor, Wheeled, DED, Loader Backhoe: with Hydraulic Impact Tool and with Hydraulic Earth Auger Attachment [John Deere Model JD410 (CCE)] with Bucket, Impactor, and Earth Drill, NSN 2420-00-567-0135	TM 5-2420-222-10
Organizational Maintenance Manual for Tractor, Wheeled, DED, Loader Backhoe: with Hydraulic Impact Tool and with Hydraulic Earth Auger Attachment [John Deere Model JD410 (CCE)] with Bucket, Impactor, and Earth Drill, NSN 2420-00-567-0135.....	TM 5-2420-222-20
Organizational Maintenance Repair Parts and Special Tools Lists for Tractor, Wheeled, DED, Loader Backhoe: with Hydraulic Impact Tool and with Hydraulic Earth Auger Attachment [John Deere Model JD410 (CCE)] with Bucket, Impactor, and Earth Drill, NSN 2420-00-567-0135	TM 5-2420-222-20P

A-5. TECHNICAL BULLETINS.

Color, Marking, and Camouflage Painting of Military Vehicles, Construction Equipment, and Materials Handling Equipment	TB 43209
Elimination of Combustibles From Interiors of Metal or Plastic Gasoline and Diesel Fuel Tanks	TB 750-1047
Equipment Improvement Report and Maintenance Digest (U.S. Army Tank-Automotive Command) Tank-Automotive Equipment	TB 43000141-Series
Purging, Cleaning and Coating Interior Ferrous and Terne Sheet Vehicle Fuel Tanks	TB 430212

A-6. TECHNICAL MANUALS.

Cooling Systems: Tactical Vehicles	TM 750-254
Inspection, Care, and Maintenance of Antifriction Bearings.....	TM 9-214
Materials Used for Cleaning, Preserving, Abrading, and Cementing Ordnance Materiel and Related Items Including Chemicals	TM 9-247
Operator's and Organizational Maintenance Manual (Including Repair Parts and Special Tools) for Tester, Diesel Fuel Injector Nozzle.....	TM 9-491409-12
Operator's Manual For Welding Theory and Application.....	TM 9-237
Operator's, Unit, Direct Support, and General Support Maintenance Manual for Care, Maintenance, Repair and Inspection of Pneumatic Tires and Inner Tubes	TM 9-2610200-14
Painting Instructions for Army Materiel.....	TM 43-0139
Procedures for Destruction of Equipment to Prevent Enemy Use	TM 750-244-3

A-7. OTHER PUBLICATIONS.

8-100	Army Medical Department Expendable/Durable Items	C
	Camouflage Pattern Painting	TC 5-200
	Expendable/Durable Items (Except Medical, Class V, Repair Parts, and Heraldic Items)	CTA 50970
	First Aid for Soldiers	FM 21-11

**APPENDIX B
EXPENDABLE/DURABLE SUPPLIES AND MATERIALS LIST**

Section I. INTRODUCTION

B-1. SCOPE.

This appendix lists expendable/durable supplies and materials you will need to operate and maintain the loader backhoe. This listing is for informational purposes only and is not authority to requisition the listed items. These items are authorized to you by CTA 50-970, Expendable/Durable Items (Except Medical, Class V, Repair Parts, and Heraldic Items), or CTA 8-100, Army Medical Department Expendable/Durable Items.

B-2. EXPLANATION OF COLUMNS.

a. **Column (1) - Item Number.** This number is assigned to the entry in the listing and is referenced in the "Initial Setup" of maintenance paragraphs or narrative instructions to identify the material needed (e.g., Dry cleaning solvent, Item 31, Appendix B).

b. **Column (2) - Level.** This column identifies the lowest level of maintenance that requires the listed item.

C - Operator/Crew
O - Organizational Maintenance
F - Direct Support Maintenance
H - General Support Maintenance

c. **Column (3) - National Stock Number.** This is the National Stock Number assigned to the item. Use it to request or requisition the item.

d. **Column (4) - Description.** Indicates the Federal item name and, if required, a description to identify the item. The last line for each item indicates the Commercial and Government Entity (CAGE) Code in parentheses followed by the part number, if applicable.

e. **Column (5) - Unit of Measure (U/M).** Indicates the measure used in performing the actual maintenance function. This measure is expressed by a two-character alphabetical abbreviation (e.g., ea, in., pr). If the unit of measure differs from the unit of issue, requisition the lowest unit of issue that will satisfy your requirements.

SECTION II. EXPENDABLE SUPPLIES AND MATERIALS LIST

(1) ITEM NUMBER	(2) LEVEL	(3) NATIONAL STOCK NUMBER	(4) DESCRIPTION (CAGE) PART NO.	(5) UNIT OF MEAS.
1	O	8040-00-016-9998	ADHESIVE: Metal Bonding (05866) R313-207 0.5 Ounce Carton	oz
2	O	6810-00-205-6790 6810-00-205-6786 6810-00-782-2686 6810-00-543-7415	ALCOHOL: Denature (81348) O-E-00760 4 Ounce Bottle 1 Quart Bottle 1 Gallon Bottle 5 Gallon Bottle	oz qt gl gl
3	F	7920-00-061-0038	BRUSH: Scrub (81348) H-B-1490	ea
4	F		BRUSH: Wire (17987) 15SS 7920-00-900-3577	ea
5	F	5350-00-192-5047 5350-00-192-5049 5350-00-192-5051	CLOTH: Abrasive (58536) A-A1048 80 Grit - 50 Sheets 120 Grit - 50 Sheets 180 Grit - 50 Sheets	ea ea ea
6	F	5350-00-174-0985	CLOTH: Abrasive (81348) GGG-C-520 600 Grit - 100 Sheets	ea
7	O	5350-00-221-0872	CLOTH: Abrasive, Crocus (81348) P-C-458 50 Sheets	ea
8	F	6850-01-085-1432	COMPOUND: Carbon Removing 13 Ounce Can	oz

SECTION II. EXPENDABLE SUPPLIES AND MATERIALS LIST

(1) ITEM NUMBER	(2) LEVEL	(3) NATIONAL STOCK NUMBER	(4) DESCRIPTION (CAGE) PART NO.	(5) UNIT OF MEAS.
9	F	7930-00-899-9534	COMPOUND: Dishwashing, Hand (81348) P-D-410 5 Gallon Can	gl
10	F	5350-00-193-1340 5350-00-193-1341 5350-00-193-1348 5350-00-193-1349	COMPOUND: Lapping and Grinding (58536) A-A-1203 150 Grit - 1 Pound Can 220 Grit - 1 Pound Can 400 Grit - 1 Pound Can 500 Grit - 1 Pound Can	lb lb lb lb
11	O	8030-00-252-3391	COMPOUND: Sealing (81349) MIL-S-45180 11 Ounce Tube	oz
12	F	8030-01-054-0740	COMPOUND: Sealing, Pipe, Anaerobic, with Teflon (05972) 592-31 50 Milliliter Tube	ml
13	C	7930-00-282-9699	DETERGENT: General Purpose, Liquid (81349) MIL-D-16791 1 Gallon Can	gl
14	F	8010-00-652-3626	DYE: Prussian Blue (81349) MIL-P-30501 1 Ounce Tube	oz
15	C	915-0935-9807 9150-00-935-9809 9150-00-935-9810	FLUID: Hydraulic, Petroleum Base (81349) MIL-H-6083 1 Quart Can 5 Gallon Can 55 Gallon Drum	qt gl gl
16	O	3439-00-255-9935	FLUX: Soldering (58536) A-A-51145 TY 1 Form A 1 Pound Can	lb
			B-3	

SECTION II. EXPENDABLE SUPPLIES AND MATERIALS LIST

(1) ITEM NUMBER	(2) LEVEL	(3) NATIONAL STOCK NUMBER	(4) DESCRIPTION (CAGE) PART NO.	(5) UNIT OF MEAS.
17	C	9140-00-286-5295 9140-00-286-5296 9140-00-286-5297	FUEL OIL, DIESEL: DF-2, Regular (81348) VV-F-800 5 Gallon Can 55 Gallon Drum, 16 Gage 55 Gallon Drum, 18 Gage	gl gl gl
18	F	5210-00-640-6176	GAGE: Bearing Clearance, 0.004-0.009 Inch (77220) PLASTIGAGEPB1 12 per Box	ea
19	F	5210-00-640-6177	GAGE: Bearing Clearance, 0.001-0.003 Inch (77220) PG-1 12 per Box	ea
20	F	5210-00-640-6178	GAGE: Bearing Clearance, 0.002-0.006 Inch (77220) PLASTIGAGEPR1 12 per Box	ea
21	F	8415-01-244-5732 8415-01-244-5733 8415-01-244-5734	GLOVES: Plastic (26921) 99P-3024 Size Small (26921) 99P-3024 SMALL 100 per Box Size Medium (26921) 99P-3024 MEDIUM 100 per Box Size Large (26921) 99P-3024 LARGE 100 per Box	ea ea ea

SECTION II. EXPENDABLE SUPPLIES AND MATERIALS LIST

(1) ITEM NUMBER	(2) LEVEL	(3) NATIONAL STOCK NUMBER	(4) DESCRIPTION (CAGE) PART NO.	(5) UNIT OF MEAS.
22	C	9150-00-935-1017 9150-00-190-0904 9150-00-1900905 9150-00-190-0907 9150-00-530-7369	GREASE: Automotive and Artillery (81349) MIL-G-10924 14 Ounce Cartridge 1.75 Pound Can 6.50 Pound Can 35 Pound Pail 120 Pound Drum	oz lb lb lb lb
23	F		LOCKTITE (23892) 0216348	
24	O	9150-01-035-9142	LUBRICANT: Impactor (74684) HTC-AE988 14 Ounce Cartridge	oz
25	C	9150-00-186-6681 9150-00-188-9858 9150-00-189-6729	OIL: Lubricating, Internal Combustion Engine, Tactical Service, OE/HDO 30 (81349) MIL-L-2104 1 Quart Can 5 Gallon Can 55 Gallon Drum	qt gl gl
26	F	9150-00-261-7899	OIL: Penetrating (81348) VV-216 1 Pint Can	Pt
27	F	5350-00-598-5537	PAPER: Abrasive (58536) A-A-1202 Fine	hd
28	C	7920-00-205-1711	RAG: Wiping Cotton and Cotton-synthetic, White (58536) A-A-531 50 Pound Bale	lb
29	F	3439-00-247-6921 3439-00-265-7102	SOLDER: Lead Alloy (81348) QQ-S-571 1 Pound Bar 1 Pound Spool/Roll	lb lb

SECTION II. EXPENDABLE SUPPLIES AND MATERIALS LIST

(1) ITEM NUMBER	(2) LEVEL	(3) NATIONAL STOCK NUMBER	(4) DESCRIPTION (CAGE) PART NO.	(5) UNIT OF MEAS.
30	O	3439-01-007-5491	SOLDER: Tin Alloy (81348) QQ-S-571 1 Pound Spool	lb
31	C	6850-00-110-4498 6850-00-664-5685 6850-00-281-1985 6850-00-274-5421 6850-00-285-8011	SOLVENT: Dry Cleaning, Type II (81349) P-D-680 1 Pint Can 1 Quart Can 1 Gallon Can 5 Gallon Can 55 Gallon Drum	Pt qt gl gl gl
32	O	9905-00-537-8954	TAG: Marker (81349) MIL-T-12755 50 Each	ea
33	O	7510-00-920-3334	TAPE: Adhesive (18876) MPD11855TYPEA248NWIDE 42 Yard Roll	yd
34	F	8030-00-067-7368 8030-00-889-3535	TAPE: Antiseizing 1/4 Inch Wide (71643) TEMPPTH 54 Feet Long 1/2 Inch Wide (76381) 4B 260 Inches Long	ft in.
35	O	5640-00-103-2254	TAPE: Duct, 2 Inch Width (07124) C-519 60 Yard Roll	yd
36	O	5970-01-144-8969	TAPE: Electrical, Nonconducting, Adhesive (76381)1194 108 Foot Roll	ft

SECTION II. EXPENDABLE SUPPLIES AND MATERIALS LIST

(1) ITEM NUMBER	(2) LEVEL	(3) NATIONAL STOCK NUMBER	(4) DESCRIPTION (CAGE) PART NO.	(5) UNIT OF MEAS.
37	O	4020-00-033-7695	TAPE: Lacing and Tying (18876) 9110503 500 Yard Roll	yd
38	O	7510-00-473-9513	TAPE: Pressure Sensitive Adhesive, Masking, Flat, 2 Inch Width (81349) MIL-T-2397 60 Yard Roll	yd
39	F	2835-01-170-9896	TAPE: Teflon (59364) 722-010-9024 100 Foot Roll	ft
40	O	6830-01-325-5586	TRICHLOROTRIFLUOROETHANE: Technical (22527) T-180 4 Liter Cylinder	li
41	F	4710-01-229-6064	TUBING: Shrink (06090) TAT-.375X4 INCH ea	
42	F	8010-01-022-3560	VARNISH: Insulating (78580) U-372 55 Gallon Drum	91
43	F	8305-01-301-1031	WIPES: Lint-free (28480) 92193W ea	ea
44	O	9505-00-596-0191	WIRE: Nonelectrical (81348) QQ-W-461 5 Pound Roll	lb
			B-7	

APPENDIX C
ILLUSTRATED LIST OF MANUFACTURED ITEMS

Section I. INTRODUCTION

C-1. GENERAL.

a. This appendix includes complete instructions for making items authorized to be manufactured or fabricated at Direct Support or General Support Maintenance.

b. All bulk materials needed to manufacture the item are listed by National Stock Number (NSN), part number, or specification number in the manufacturing Instructions.

c. All dimensions given in Section II, Manufactured Items Illustrations, are in standard units.

Section II. MANUFACTURED ITEMS ILLUSTRATIONS

1. Fabricate from tool grade steel.
2. Cut and assemble in accordance with illustration.

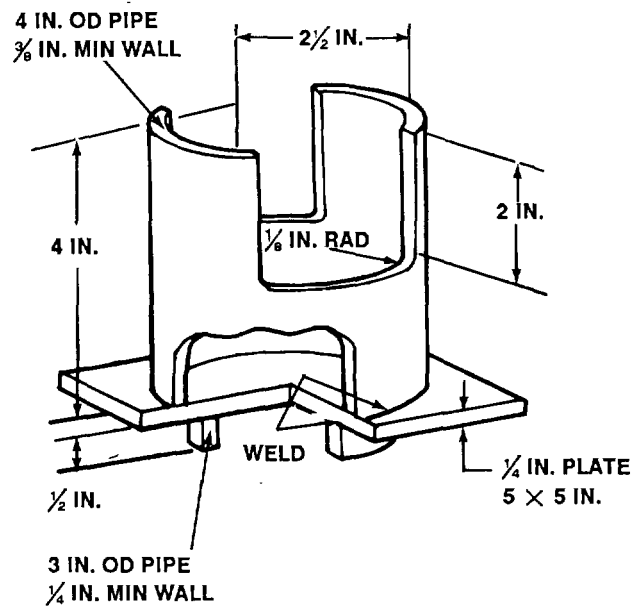

Figure C-1. Spring Compression Tool.

**APPENDIX D
TORQUE LIMITS**

D-1. SCOPE.

This appendix lists standard torque values, as shown in Table D-1, and provides general information for applying torque. Special torque values and tightening sequences are indicated in the maintenance procedures for applicable components.







D-2. GENERAL.

- a. Always use the torque values listed in Table D-1 when the maintenance procedure does not give a specific torque value.
- b. Unless otherwise indicated, standard torque tolerance shall be $\pm 10\%$.
- c. Torque values listed are based on clean, dry threads. Reduce torque by 10% when engine oil is used as a lubricant. Reduce torque by 20% if new plated capscrews are used.
- d. Capscrews threaded into aluminum may require reductions in torque of 30% or more of Grade 5 capscrew torque. Capscrew threaded into aluminum must also attain two capscrew diameters of thread engagement.

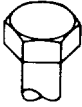
CAUTION

If replacement capscrews are of higher grade than originally supplied, use torque specifications for the original. This will prevent equipment damage due to overtorquing.

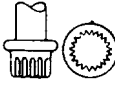
Table D-1. Torque Limits.

Current Usage	Much Used	Much Used	Used at Times	Used at Times		
Quality of Material	Indeterminate	Minimum Commercial	Medium Commercial	Best Commercial		
SAE Grade Number Capscrew Head Markings Manufacturer's marks may vary These are all SAE Grade 5 (3 line)			 	 		
Capscrew Body Size Inches - Thread	Torque lb.-ft. (Nom)		Torque lb.-ft. (Nom)		Torque lb.-ft. (Nom)	
$\frac{1}{4}$ 20 28	5 (7)	(8) (11)	10 (14)	12 (16)	(14) (19)	
5/16 18 24	11 (15)	17 (23)	19 (26)	24 (33)	(37) (37)	
3/8 16 24	18 (24)	31 (42)	34 (46)	44 (60)	(66) (66)	
7/16 14 20	28 (38)	49 (66)	55 (75)	70 (95)	(106) (106)	
$\frac{1}{2}$ 13 20	39 (53)	75 (102)	85 (115)	105 (142)	(163) (163)	
9/16 12 18	51 (69)	110 (149)	120 (163)	155 (210)	(231) (231)	
5/8 11 18	83 (113)	150 (203)	167 (226)	210 (285)	(325) (325)	
$\frac{3}{4}$ 10 16	105 (142)	270 (366)	280 (380)	375 (508)	(569) (569)	
7/8 9 14	160 (217)	395 (536)	440 (597)	605 (820)	(915) (915)	
1 8 14	235 (319)	590 (800)	660 (895)	910 (1234)	(1342) (1342)	

INDEX

<i>Subject</i>	<i>Paragraph</i>	<i>Page</i>
A		
AC Generator, Engine	7-1	7-1
Accumulator Assembly	14-2	14-7
Antiseizing Tape	1-26	1-13
Arm:		
Loader Lift	15-5	122
Rocker	3-13	3-81
Steering	9-2	9-4
Army Materiel, Destruction of, Prevent Enemy Use	1-3	1-1
Axle:		
Front	9-1	9-1
Rear:		
Bearings	9-3	9-10
Housing	9-3	9-10
Seals	9-3	9-10
Shafts	9-3	9-10
B		
Backhoe:		
Boom:		
Cylinder	14-20	14-94
Maintenance	15-2	15-8
Valve	14-12	14-60
Bucket:		
Cylinder	14-21	14-99
Valve	14-10	14-50
Control Valve	14-9	1445
Crowd:		
Cylinder	14-19	14-88
Valve	14-11	14-56
Dipperstick	15-1	15-1
Main Frame	15-4	15-17
Relief Valves	14-13	14-66

INDEX

<i>Subject</i>	<i>Paragraph</i>	<i>Page</i>
Backhoe (Con't):		
Stabilizer:		
Cylinder	14-23	14-111
Valve	14-10	14-50
Swing Frame.....	15-3	15-11
Swing:		
Cylinder	14-22	14-106
Valves	14-12	14-60
Band, Parking Brake	10-1	10-1
Bearing:		
Carrier, Clutch Support.....	4-4	4-18
Clearance Gage.....	1-16	1-7
Main, Dimensions	Table 3-1	3-52
Rear Axle	9-3	9-10
Support, Transmission.....	8-4	8-20
Block Plate, Cylinder	3-7	3-41
Boom:		
Backhoe.....	15-2	15-8
Cylinder:		
Backhoe	14-20	14-94
Loader	14-24	1120
Valve:		
Backhoe.....	14-12	14-60
Loader.....	14-15	14-74
Boring Head, Hydraulic Earth Drill:		
Motor:		
Repair.....	16-2	16-6
Replacement.....	16-1	16-1
Repair	16-3	16-11
Brackets:		
Canopy	13-1	13-1
Roll-over Protective Structure.....	13-1	13-1
Brake:		
Housing, Reverser	8-17	8-72
Hydraulic, Cylinder.....	10-4	10-20
Parking:		
Band	10-1	10-1
Lining	10-1	10-1
Linkage	10-2	10-6

INDEX

<i>Subject</i>	<i>Paragraph</i>	<i>Page</i>
Brake (Con't)		
Service:		
Disk	10-3	10-13
Pressure Plate	10-3	10-13
Bucket:		
Cylinder:		
Backhoe	14-21	14-99
Loader	14-24	14-116
Relief Valve, Loader	14-16	14-80
Valve:		
Backhoe	14-10	14-50
Loader	14-15	14-74
Bushings	3-19	3-110
C		
Cams, Control	3-19	3-110
Camshaft	3-17	3-98
Canopy:		
Brackets	13-1	13-1
Mounts:		
Front	13-1	13-1
Rear	13-4	13-13
Protective Roof:		
Serial Number 235786-235999	13-2	13-7
Serial Number 319995-342573	13-3	13-10
Carrier:		
Clutch Disk	4-4	4-18
Clutch Support Bearing	4-4	4-18
Planetary Pinion	9-3	9-10
Cleaning, General Maintenance	1-12	1-5
Clutch:		
Control Valve, Reverser	8-20	8-88
Disk:		
Carrier	4-4	4-18
Repair	8-18	8-80
Drum	8-18	8-80

INDEX

<i>Subject</i>	<i>Paragraph</i>	<i>Page</i>
Clutch (Con't)		
Manual Control Lever	4-3	4-15
Support Bearing Carrier.....	4-4	4-18
Clutch Assembly Maintenance:		
Serial Numbers 235786-235999.....	4-1	4-1
Serial Numbers 319995-342573.....	4-2	4-10
Column, Steering.....	11-1	11-1
Compression:		
Fittings.....	1-27	1-13
Test, Engine Assembly.....	3-1	3-2
Connecting Rod:		
Bearing	3-11	3-67
Maintenance	3-11	3-67
Connector:		
Replacement	1-21	1-10
Wiring Harness	1-23	1-11
Control Cams	3-19	3-110
Control Lever:		
Clutch.....	4-3	4-15
Linkage, Reverser	8-15	8-64
Control Valve:		
Backhoe.....	14-9	14-45
Jaw	14-8	14-40
Loader.....	14-14	14-72
Reverser Clutch.....	8-20	8-88
Stroke:		
Repair.....	14-6	14-32
Solenoid	14-7	14-38
Countershaft, Transmission	8-4	8-20
Coupler, Hydraulic Pump:		
Serial Numbers 235786-235999.....	14-4	14-26
Serial Numbers 319995-342573.....	14-5	14-29
Cover:		
Reverser Speed Top	8-11	8-54
Timing Gear	3-18	3-103
Transmission:		
Rear	8-3	8-18
Top:		
Serial Numbers 235786-235999	8-12	8-56
Serial Numbers 319995-242573	8-13	8-60

INDEX

<i>Subject</i>	<i>Paragraph</i>	<i>Page</i>
Cowl Support.....	13-5	13-25
Crankshaft.....	3-8	3-44
Crowd:		
Cylinder, Backhoe.....	14-19	14-88
Valve, Backhoe.....	14-11	14-56
Cylinder:		
Assemblies, Steering.....	11-2	11-7
Backhoe:		
Boom.....	14-20	14-94
Bucket.....	14-21	14-99
Crowd.....	14-19	14-88
Stabilizer.....	14-23	14-111
Swing.....	14-22	14-106
Block Plate.....	3-7	3-41
Head.....	3-6	3-36
Hydraulic Brake.....	10-4	10-20
Jaw.....	14-18	14-84
Loader:		
Boom.....	14-25	14-120
Bucket.....	14-24	14-116
Sleeve.....	3-5	3-32

D

Data, Equipment.....	1-6	1-2
Destruction of Army Materiel to Prevent Enemy Use.....	1-3	1-1
Diameter Specifications, Valve:		
Guide.....	Table 3-2	3-79
Stem.....	Table 3-2	3-79
Differences Between Models.....	1-5	1-2
Differential:		
Assembly.....	8-7	8-34
Drive Shaft.....	8-6	8-29
Linkage.....	8-8	8-42
Lock:		
Mechanism.....	8-9	8-44
Pedal.....	8-8	8-42

INDEX

<i>Subject</i>	<i>Paragraph</i>	<i>Page</i>
Dimensions:		
Journal	Table 3-1	3-52
Main Bearing.....	Table 3-1	3-52
Dipperstick, Backhoe.....	15-1	15-1
Disk:		
Carrier, Clutch.....	4-4	4-18
Reverser Clutch.....	8-18	8-80
Service Brake	10-3	10-13
Disposal, Fluid.....	1-29	1-15
Drill Boring Head, Hydraulic Earth:		
Motor:		
Repair.....	16-2	16-6
Replacement.....	16-1	16-1
Repair	16-3	16-11
Drive Shaft:		
Differential.....	8-6	8-29
Hydraulic Pump:		
Serial Numbers 235786-235999	14-4	14-26
Serial Numbers 319995-342573	14-5	14-29
Transmission	8-5	8-25
Drum, Reverser Clutch.....	8-18	8-80

E

Earth Drill Boring Head, Hydraulic:		
Motor:		
Repair.....	16-2	16-6
Replacement.....	16-1	16-1
Repair	16-3	16-11
Electrical Ground Points.....	1-24	1-12
Engine:		
AC Generator.....	7-1	7-1
Block.....	3-4	3-22
Flywheel.....	3-9	3-59
Oil Pan.....	3-20	3-115
Oil Pump.....	3-21	3-120

INDEX

<i>Subject</i>	<i>Paragraph</i>	<i>Page</i>
Engine (Con't):		
Starter	7-2	7-14
Timing	3-16	3-96
Engine Assembly:		
Compression Test	3-1	3-2
Replacement	3-3	3-7
Vacuum Test	3-2	3-5
Equipment:		
Data	1-6	1-2
Improvement Recommendations, Reporting	1-4	1-1

F

Fenders	13-6	13-32
Fittings:		
Compression	1-27	1-13
Hydraulic	14-17	14-84
Fluid Disposal	1-29	1-15
Flywheel:		
Engine	3-9	3-59
Housing	3-10	3-62
Frame:		
Assembly Front Support	12-1	12-1
Backhoe:		
Main	15-4	15-17
Swing	15-3	15-11
Loader Side	15-6	15-28
Front Axle	9-1	9-1
Front Mounts:		
Canopy	13-1	13-1
Roll-over Protective Structure	3-1	13-1
Front Support, Frame Assembly	12-1	12-1
Fuel:		
Injector Nozzles:		
Repair	5-1	5-1
Test	5-1	5-1

INDEX

<i>Subject</i>	<i>Paragraph</i>	<i>Page</i>
Fuel (Con't):		
Metering Pump:		
Helical Gear	5-3	5-15
Replacement	5-2	5-9
Tank	5-5	5-18

G

Gage, Bearing Clearance	1-16	1-7
Gear:		
Cover, Timing	3-18	3-103
Idler:		
Adjustment	3-15	3-88
Replacement	3-15	3-88
Replacement	3-19	3-110
Ring	3-9	3-59
Shifter:		
Maintenance	8-10	8-47
Shafts	8-10	8-47
Generator, Engine AC	7-1	7-1
Ground Points, Electrical	1-24	1-12
Guide Diameter Specifications, Valve	Table 3-2	3-79

H

Harness Connector, Wiring	1-23	1-11
Head, Cylinder	3-6	3-36
Heat Shrink Tubing	1-20	1-9
Helical Gear, Fuel Metering Pump	5-3	5-15
Hoses, Hydraulic	14-17	14-84
Housing:		
Flywheel	3-10	3-62
Rear Axle	9-3	9-10
Reverser		
Brake	8-17	8-72
Maintenance	8-16	8-65

INDEX

<i>Subject</i>	<i>Paragraph</i>	<i>Page</i>
Hydraulic:		
Brake, Cylinder	10-4	10-20
Earth Drill Boring Head:		
Motor:		
Repair	16-2	16-6
Replacement	16-1	16-1
Repair	16-3	16-11
Fittings	14-17	14-84
Hoses	14-17	14-84
Impactor:		
Motor Assembly	16-4	16-17
Repair	16-5	16-19
Lines	14-17	14-84
Pump:		
Coupler:		
Serial Numbers 235786-235999	14-4	14-26
Serial Numbers 319995-342573	14-5	14-29
Drive Shaft:		
Serial Numbers 235786-235999	14-4	14-26
Serial Numbers 319995-342573	14-5	14-29
Maintenance	14-3	14-13
Stroke Control Valve:		
Repair	14-6	14-32
Solenoid	14-7	14-38
System Test	14-1	14-2
I		
Idler Gears:		
Adjustment	3-15	3-88
Replacement	3-15	3-88
Impactor, Hydraulic:		
Motor Assembly	16-4	16-17
Injection Nozzles, Fuel:		
Repair	5-1	5-1
Test	5-1	5-1
Inspection Instructions	1-15	1-6

INDEX

<i>Subject</i>	<i>Paragraph</i>	<i>Page</i>
J		
Jaw:		
Control Valve	14-8	14-40
Cylinder.....	14-8	14-84
Journal Dimensions.....	Table 3-1	3-52
K		
Kits, Service	1-17	1-8
L		
Lever:		
Clutch Manual Control	4-3	4-15
Linkage, Reverser Control	8-15	8-64
Reverser Shifter.....	8-14	8-62
Lift Arms, Loader	15-5	15-22
Lines:		
General Maintenance	1-25	1-13
Hydraulic.....	14-17	14-84
Reverser Oil.....	8-21	8-101
Transmission Oil.....	8-23	8-106
Linkage:		
Differential.....	8-8	8-42
Parking Brake	10-2	10-6
Reverser Control Lever.....	8-15	8-64
Loader:		
Boom:		
Cylinder	14-5	14-12 0
Valve	14-15	14-74

INDEX

<i>Subject</i>	<i>Paragraph</i>	<i>Page</i>
Loader (Con't):		
Bucket:		
Cylinder	14-24	14-116
Relief Valve	14-16	14-80
Valve	14-15	14-74
Control Valve	14-14	14-72
Lift Arm	15-5	15-22
Side Frames	15-6	15-28
Lock:		
Mechanism, Differential	8-9	8-44
Pedal, Differential	8-8	8-42
Lockwire	1-28	1-14
Lug, Wire Terminal	1-21	1-10

M

Main:		
Bearing Dimensions	Table3-1	3-52
Frame, Backhoe	15-4	15-17
Manual Control Lever, Clutch	4-3	4-15
Metering pump, Fuel:		
Helical Gear	5-3	5-15
Replacement	5-2	5-9
Models, Differences Between	1-5	1-2
Motor Assembly, Hydraulic Impactor	16-4	16-17
Mounts:		
Front:		
Canopy	13-1 1	3-1
Roll-over Protective Structure	13-1	13-1
Rear:		
Canopy	13-4	13-13
Roll-over Protective Structure	13-4	13-13

N

Nozzles, Fuel Injection:		
Repair	5-1	5-1
Test	5-1	5-1

INDEX

<i>Subject</i>	<i>Paragraph</i>	<i>Page</i>
O		
Oil:		
Lines:		
Reverser	8-21	8-101
Transmission.....	8-23	8-106
Pan, Engine	3-20	3-115
Pressure Test, Transmission.....	8-1	8-2
Pump:		
Engine	3-21	3-120
Transmission.....	8-19	8-85
P		
Painting	1-14	1-6
Parking Brake:		
Band	10-1	10-1
Lining	10-1	10-1
Linkage	10-2	10-6
Parts:		
Preservation.....	1-13	1-6
Tagging.....	1-18	1-8
Pedal, Differential Lock	8-8	8-42
Pinion Carrier, Planetary	9-3	9-10
Piston	3-11	3-67
Planetary Pinion Carrier	9-3	9-10
Plate, Cylinder Block	3-7	3-41
Ports, General Maintenance.....	1-25	1-13
Preservation of Parts.....	1-13	1-6
Pressure:		
Plate, Service Brake	10-3	10-13
Regulating Valve.....	3-22	3-125
Test, Transmission Oil.....	8-1	8-2
Pump:		
Engine Oil	3-21	3-120

INDEX

<i>Subject</i>	<i>Paragraph</i>	<i>Page</i>
Pump (Con't):		
Fuel Metering:		
Helical Gear	5-3	5-15
Replacement	5-2	5-9
Hydraulic:		
Coupler:		
Serial Numbers 235786-235999	14-4	14-26
Serial Numbers 319995-342573	14-5	14-29
Drive Shaft:		
Serial Numbers 235786-235999	14-4	14-26
Serial Numbers 319995-342573	14-5	14-29
Maintenance	14-3	14-13
Stroke Control Valve:		
Repair.....	14-6	14-32
Solenoid	14-7	14-38
Transmission Oil.....	8-19	8-85
Pushrod	3-13	3-81
R		
Radiator	6-1	6-1
Rear Axle:		
Bearings.....	9-3	9-10
Housing.....	9-3	9-10
Seals	9-3	9-10
Shafts	9-3	9-10
Rear Cover, Transmission.....	8-3	8-18
Rear Mounts:		
Canopy	134	13-13
Roll-over Protective Structure.....	13-4	13-13
Regulating Valve, Pressure.....	3-22	3-125
Relief Valve:		
Backhoe.....	14-13	14-66
Loader Bucket	14-16	14-80
Transmission	8-22	8-104
Reporting Equipment Improvement Recommendations	1-4	1-1

INDEX

<i>Subject</i>	<i>Paragraph</i>	<i>Page</i>
Reverser:		
Brake Housing	8-17	8-72
Clutch:		
Control Valve.....	8-20	8-88
Disk	8-18	8-80
Drum	8-18	8-80
Control Lever Linkage.....	8-15	8-64
Housing.....	8-16	8-65
Oil Lines.....	8-21	8-101
Shifter Levers.....	8-14	8-62
Speed Top Cover.....	8-11	8-54
Ring Gear	3-9	3-59
Rocker Arm	3-13	3-81
Rod:		
Bearing, Connecting	3-11	3-67
Connecting.....	3-11	3-67
Roll-over Protective Structure (ROPS):		
Brackets	13-1	13-1
Mounts, Front.....	13-1	13-1
Mounts, Rear	13-4	13-13
Roof, Canopy Protective:		
Serial Numbers 235786-235999.....	13-2	13-7
Serial Numbers 319995-342573.....	13-3	13-10
S		
Seals, Rear Axle.....	9-3	9-10
Service:		
Brake:		
Disk	10-3	10-13
Pressure Plate	10-3	10-13
Replacement Kits	1-17	1-8
Shaft:		
Differential Drive	8-6	8-29
Gear Shifter	8-10	8-47
Maintenance	3-13	3-81
Rear Axle	9-3	9-10

INDEX

<i>Subject</i>	<i>Paragraph</i>	<i>Page</i>
Shaft (Con't):		
Speed Control.....	5-5	5-18
Transmission Drive.....	8-5	8-25
Shifter:		
Levers, Reverser	8-14	8-62
Maintenance, Gear	8-10	8-47
Shafts, Gear	8-10	8-47
Side Frames, Loader.....	15-6	15-28
Sleeve, Cylinder.....	3-5	3-32
Soldering	1-19	1-9
Speed:		
Control Shaft.....	5-5	5-18
Top Cover, Reverser	8-11	8-54
Spindle, Wheel	9-2	9-4
Stabilizer:		
Cylinder, Backhoe.....	14-23	14-111
Valve, Backhoe.....	14-10	14-50
Starter, Engine.....	7-2	7-14
Steering:		
Arms	9-2	9-4
Column	11-1	11-1
Cylinder Assemblies	11-2	11-7
Valve:		
Assembly.....	11-3	11-18
Support.....	11-1	11-1
Stem Diameter Specifications, Valve	Table 3-2	3-79
Stroke Control Valve:		
Repair	14-6	14-32
Solenoid.....	14-7	14-38
Support:		
Bearing Carrier, Clutch	4-4	4-18
Cowl	13-5	13-25
Frame Assembly, Front	12-1	12-1
Maintenance	13-6	13-32
Transmission Bearing.....	8-4	8-20
Valve, Steering	11-1	11-1
Swing:		
Cylinder, Backhoe.....	14-22	14-106
Frame, Backhoe	15-3	15-11
Valves, Backhoe.....	14-12	14-60

INDEX

<i>Subject</i>	<i>Paragraph</i>	<i>Page</i>
Symptom Index, Troubleshooting.....	2-3	2-2
System Test, Hydraulic.....	14-1	14-2
T		
Tagging	1-18	1-8
Tank, Repair	5-4	5-18
Tape, Antiseizing.....	1-26	1-13
Tappet	3-14	3-86
Terminal Lug, Wire	1-21	1-10
Test:		
Engine Assembly:		
Compression.....	3-1	3-2
Vacuum.....	3-2	3-5
Hydraulic System.....	14-1	14-2
Transmission Oil Pressure	8-1	8-2
Timing:		
Engine	3-16	3-96
Gear Cover	3-18	3-103
Top Cover, Reverser Speed.....	8-11	8-54
Transmission:		
Bearing Support.....	8-4	8-20
Countershaft	8-4	8-20
Drive Shaft.....	8-5	8-25
Maintenance	8-2	8-5
Oil:		
Lines.....	8-23	8-106
Pressure Test.....	8-1	8-2
Pump.....	8-19	8-85
Rear Cover	8-3	8-18
Relief Valve.....	8-22	8-104
Top Cover, Transmission:		
Serial Numbers 235786-235999	8-12	8-56
Serial Numbers 319995-242573	8-13	8-60
Troubleshooting.....	Table 2-1	2-3
Troubleshooting, Symptom Index.....	2-3	2-2
Tubes, General Maintenance	1-27	1-13
Tubing, Heat Shrink.....	1-20	1-9

INDEX

<i>Subject</i>	<i>Paragraph</i>	<i>Page</i>
V		
Vacuum Test, Engine Assembly	3-2	3-5
Valve:		
Assembly, Steering.....	11-3	11-18
Backhoe:		
Boom.....	14-12	14-60
Bucket.....	14-10	14-50
Control.....	14-9	14-45
Crowd.....	14-11	14-56
Relief.....	14-13	14-66
Swing.....	14-12	14-60
Guide Diameter Specifications	Table 3-2	3-79
Jaw Control.....	14-8	14-40
Loader:		
Boom	14-15	14-74
Bucket:		
Relief.....	14-16	14-80
Repair.....	14-15	14-74
Control	14-14	14-72
Maintenance	3-12	3-77
Pressure Regulating.....	3-22	3-125
Reverser Clutch Control	8-20	8-88
Stem Diameter Specifications	Table 3-2	3-79
Stroke Control:		
Repair	14-6	14-32
Solenoid.....	14-7	14-38
Support, Steering.....	11-1	11-1
Transmission Relief.....	8-22	8-104
W		
Wheel Spindles	9-2	9-4
Wire:		
Connector	1-21	1-10

INDEX

<i>Subject</i>	<i>Paragraph</i>	<i>Page</i>
Wire (Con't):		
Replacement	1-22	1-10
Terminal Lug.....	1-21	1-10
Wiring Harness Connector Repair and Replacement	1-23	1-11
Work Safety	1-11	1-5

By Order of the Secretary of the Army:

Official:

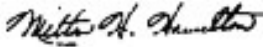

MILTON H. HAMILTON
*Administrative Assistant to the
Secretary of the Army*
02938

GORDON R. SULLIVAN
*General, United States Army
Chief of Staff*

Distribution:

To be distributed in accordance with DA Form 12-25-E (Block 5763) requirements for TM5-2420-222-34.

RECOMMENDED CHANGES TO EQUIPMENT TECHNICAL PUBLICATIONS



THEN... JOT DOWN THE DOPE ABOUT IT ON THIS FORM, CAREFULLY TEAR IT OUT, FOLD IT AND DROP IT IN THE MAIL!

SOMETHING WRONG WITH THIS PUBLICATION?

FROM: (PRINT YOUR UNIT'S COMPLETE ADDRESS)

DATE SENT

PUBLICATION NUMBER

TM 11-5825-270-10

PUBLICATION DATE

23 Jul 81

PUBLICATION TITLE

Radio Frequency R-2176/FRN

BE EXACT... PIN-POINT WHERE IT IS

PAGE NO.	PARA-GRAPH	FIGURE NO.	TABLE NO.

IN THIS SPACE TELL WHAT IS WRONG AND WHAT SHOULD BE DONE ABOUT IT:

TEAR ALONG PERFORATED LINE

PRINTED NAME, GRADE OR TITLE, AND TELEPHONE NUMBER

SIGN HERE:

DA FORM 2028-2
1 JUL 79

PREVIOUS EDITIONS ARE OBSOLETE.

P.S.—IF YOUR OUTFIT WANTS TO KNOW ABOUT YOUR RECOMMENDATION MAKE A CARBON COPY OF THIS AND GIVE IT TO YOUR HEADQUARTERS.

THE METRIC SYSTEM AND EQUIVALENTS

LINEAR MEASURE

- 1 Centimeter = 10 Millimeters = 0.01 Meters = 0.3937 Inches
- 1 Meter = 100 Centimeters = 1,000 Millimeters = 39.37 Inches
- 1 Kilometer = 1,000 Meters = 0.621 Miles

SQUARE MEASURE

- 1 Sq Centimeter = 100 Sq Millimeters = 0.155 Sq Inches
- 1 Sq Meter = 10,000 Sq Centimeters = 10.76 Sq Feet
- 1 Sq Kilometer = 1,000,000 Sq Meters = 0.386 Sq Miles

CUBIC MEASURE

- 1 Cu Centimeter = 1,000 Cu Millimeters = 0.06 Cu Inches
- 1 Cu Meter = 1,000,000 Cu Centimeters = 35.31 Cu Feet

LIQUID MEASURE

- 1 Milliliter = 0.001 Liters = 0.0338 Fluid Ounces
- 1 Liter = 1,000 Milliliters = 33.82 Fluid Ounces

TEMPERATURE

- $5/9 (^{\circ}\text{F} - 32) = ^{\circ}\text{C}$
- 212° Fahrenheit is equivalent to 100° Celsius
- 90° Fahrenheit is equivalent to 32.2° Celsius
- 32° Fahrenheit is equivalent to 0° Celsius
- $9/5 \text{ C}^{\circ} + 32 = \text{F}^{\circ}$

WEIGHTS

- 1 Gram = 0.001 Kilograms = 1,000 Milligrams = 0.035 Ounces
- 1 Kilogram = 1,000 Grams = 2.2 lb.
- 1 Metric Ton = 1,000 Kilograms = 1 Megagram = 1.1 Short Tons

APPROXIMATE CONVERSION FACTORS

TO CHANGE	TO	MULTIPLY BY
Inches	Centimeters	2.540
Feet	Meters	0.305
Yards	Meters	0.914
Miles	Kilometers	1.609
Square Inches	Square Centimeters	6.451
Square Feet	Square Meters	0.093
Square Yards	Square Meters	0.836
Square Miles	Square Kilometers	2.590
Acres	Square Hectometers	0.405
Cubic Feet	Cubic Meters	0.028
Cubic Yards	Cubic Meters	0.765
Fluid Ounces	Milliliters	29.573
Pints	Liters	0.473
Quarts	Liters	0.946
Gallons	Liters	3.785
Ounces	Grams	28.349
Pounds	Kilograms	0.454
Short Tons	Metric Tons	0.907
Pound-Feet	Newton-Meters	1.356
Pounds Per Square Inch	Kilopascals	6.895
Miles Per Gallon	Kilometers Per Liter	0.425
Miles Per Hour	Kilometers Per Hour	1.609
TO CHANGE	TO	MULTIPLY BY
Centimeters	Inches	0.394
Meters	Feet	3.280
Meters	Yards	1.094
Kilometers	Miles	0.621
Square Centimeters	Square Inches	0.155
Square Meters	Square Feet	10.764
Square Meters	Square Yards	1.196
Square Kilometers	Square Miles	0.386
Square Hectometers	Acres	2.471
Cubic Meters	Cubic Feet	35.315
Cubic Meters	Cubic Yards	1.308
Milliliters	Fluid Ounces	0.034
Liters	Pints	2.113
Liters	Quarts	1.057
Liters	Gallons	0.264
Grams	Ounces	0.035
Kilograms	Pounds	2.205
Metric Tons	Short Tons	1.102
Newton-Meters	Pound-Feet	0.738
Kilopascals	Pounds Per Square Inch	0.145
Kilometers Per Liter	Miles Per Gallon	2.354
Kilometers Per Hour	Miles Per Hour	0.621

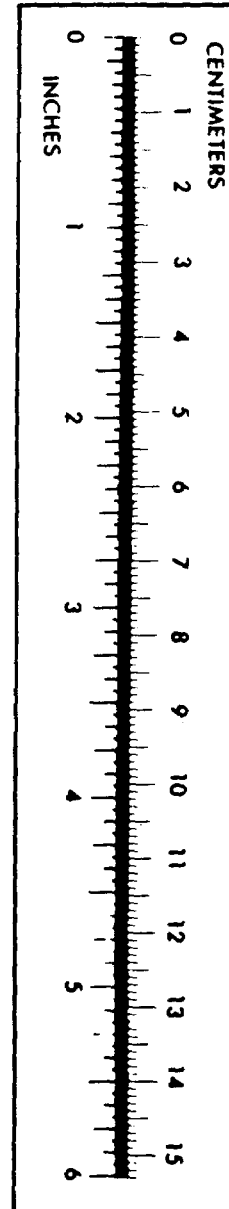

PIN: 070538-000